

# ABRIDGED DATA SHEET

Click [here](#) for production status of specific part numbers.

## MAX20092

## 12-Switch Matrix Manager for Automotive Lighting

### General Description

The MAX20092 12-switch matrix manager IC for automotive lighting applications includes a 12-switch array for bypassing individual LEDs in a single- or dual-string application. It features 12 individually controlled n-channel MOSFET switches rated for 10V with on-resistance of 0.100Ω. A single current source can be used to power all the LEDs connected in series. Individual LEDs can be dimmed by turning on and off the bypass switches across each LED, and can also be configured in 2 strings with 6 switches in series per string and 4 strings with 3 switches per string. A separate current source powers each string. Each switch can be connected across 1 or 2 LEDs in series. The IC also includes an internal charge pump that provides power for the gate drive of each of the LED bypass switches. The low on-resistance of the switches minimizes conduction loss and power dissipation.

The IC features a serial peripheral interface (SPI) for serial communication. The MAX20092 is a slave device that uses the SPI to communicate with an external micro-controller (μC), which is the master device. Each of the 12 switches can be independently programmed to bypass the LEDs across each of the switches in the string. Each switch can be turned fully on, fully off, or dimmed with or without fade-transition mode. The PWM frequency can be set by an internal oscillator or set to an external clock source. The IC features open-LED protection as well as open- and short-LED fault reporting through the SPI. The MAX20092 is available in a 32-pin (5mm x 5mm) side-wettable TQFN (SWTQFN) package with a thermally enhanced exposed pad.

### Applications

- Automotive Front-Light Systems
- Automotive Tail-Light Systems
- Automotive Matrix-Lighting Systems

### Benefits and Features

- Automotive Ready: AEC-Q100 Qualified
- Flexible Configuration Allows the Use of the Same Device in Different Applications
  - Single-, Dual-, and Quad-String Configurations
  - Up to 12 Switches in Series in Single-String Configurations
  - Up to 6 Switches in Series in Dual-String Configurations
  - Up to 3 Switches in Series in Quad-String Configurations
  - Up to 2 LEDs per Switch
- Optimal PWM Dimming Arrangement Provides Excellent Dimming Performance
  - Programmable 12-Bit PWM Dimming
  - Fade Transition Between PWM Dimming States
  - Internal Clock Generator or External Clock for PWM Dimming
- Protection Features and Package Improve Reliability
  - Open-LED Protection
  - Programmable Open-LED and Shorted-LED Threshold
  - Open- and Shorted-LED Fault Reporting
  - Thermally Enhanced 32-Pin SWTQFN Package

*Ordering Information* appears at end of data sheet.

### Simplified Block Diagram

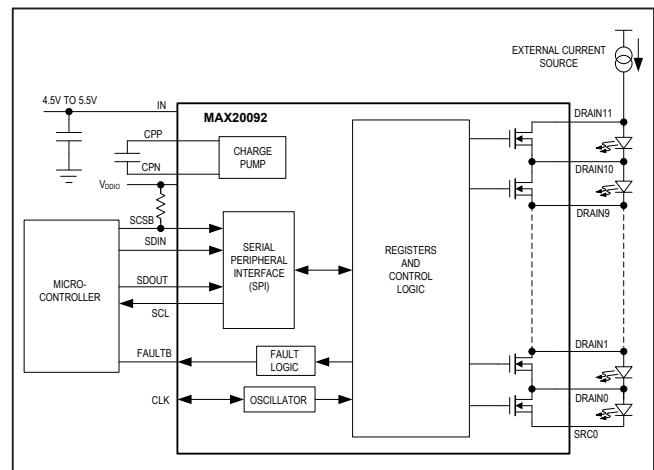

# ABRIDGED DATA SHEET

MAX20092

12-Switch Matrix Manager for Automotive Lighting

## Ordering Information

| PART             | TEMP RANGE      | PIN-PACKAGE   |
|------------------|-----------------|---------------|
| MAX20092ATJ/VY+  | -40°C to +125°C | 32 SWTQFN-EP* |
| MAX20092ATJ/VY+T | -40°C to +125°C | 32 SWTQFN-EP* |

*V* Denotes an automotive-qualified part.

*+* Denotes a lead(Pb)-free/RoHS-compliant package.

SW = Side-wettable TQFN package.

\*EP = Exposed pad.

T = Tape-and-reel package.

## X-ON Electronics

Largest Supplier of Electrical and Electronic Components

*Click to view similar products for [LED Lighting Drivers](#) category:*

*Click to view products by [Maxim](#) manufacturer:*

Other Similar products are found below :

[LV5235V-MPB-H](#) [MB39C602PNF-G-JNEFE1](#) [MIC2871YMK-T5](#) [AL1676-10BS7-13](#) [AL1676-20AS7-13](#) [AP5726WUG-7](#) [MX877RTR](#)  
[ICL8201](#) [IS31BL3228B-UTLS2-TR](#) [IS31BL3506B-TTLS2-TR](#) [AL3157F-7](#) [AP5725FDCG-7](#) [AP5726FDCG-7](#) [LV52204MTTBG](#)  
[AP5725WUG-7](#) [STP4CMPQTR](#) [NCL30086BDR2G](#) [CAT4004BHU2-GT3](#) [LV52207AXA-VH](#) [AP1694AS-13](#) [TLE4242EJ](#) [AS3688](#)  
[IS31LT3172-GRLS4-TR](#) [TLD2311EL](#) [KTD2694EDQ-TR](#) [KTZ8864EJAA-TR](#) [IS32LT3174-GRLA3-TR](#) [ZXLD1374QESTTC](#) [MP2488DN-](#)  
[LF-Z](#) [NLM0010XTSA1](#) [AL1676-20BS7-13](#) [MPQ7220GF-AEC1-P](#) [MPQ4425BGJ-AEC1-P](#) [MPQ7220GF-AEC1-Z](#) [MPQ4425BGJ-AEC1-Z](#)  
[IS31FL3737B-QFLS4-TR](#) [IS31FL3239-QFLS4-TR](#) [KTD2058EUAC-TR](#) [KTD2037EWE-TR](#) [DIO5662ST6](#) [IS31BL3508A-TTLS2-TR](#)  
[MAX20052CATC/V+](#) [MAX25606AUP/V+](#) [BD6586MUV-E2](#) [BD9206EFV-E2](#) [BD9416FS-E2](#) [LYT4227E](#) [LYT6079C-TL](#) [MP3394SGF-P](#)  
[MP4689AGN-P](#)