

## General Description

The MAX20317 evaluation kit (EV kit) is a fully assembled and tested circuit board that demonstrates the MAX20317 universal 3.5mm jack accessory management device. The EV kit comes with the MAX20317EWP+ installed.

## Features

- 3V to 5.5V Operating Voltage Range
- Audio Jack for Accessory Plug In
- Proven PCB Layout
- Fully Assembled and Tested

## EV Kit Contents

- EV Kit Board Containing a MAX20317

[Ordering Information](#) appears at end of data sheet.

## Detailed Description

The MAX20317 EV kit is a fully assembled and tested circuit board demonstrating the MAX20317 universal 3.5mm jack accessory management device in a 20-bump wafer-level package (WLP).

## Power Supply

Use JU1, JU3, and JU10 to select power supply sources ([Table 1](#)).

## I<sup>2</sup>C Communication

Use JU4, JU5, and JU6 to have I<sup>2</sup>C pins pulled up to VCC supply ([Table 2](#)). The user needs to provide an I<sup>2</sup>C master to communicate with the device.

## Ground Sense Inputs

Use JU12, JU13, and JU14 to select ground sense inputs connection ([Table 3](#)).

**Table 1. JU1, JU3, JU10 Jumper Setting**

JUMPER	SHUNT POSITION	DESCRIPTION
JU1	1-2	VBOOST from testing board
	2-3*	VBOOST from USB port
JU3	Installed*	VBOOST from selected source in JU1
	Not installed	VBOOST from external power on TP11
JU10	1-2	VCC from testing board
	2-3*	VCC from external power on TP23

\*Default position.

**Table 2. JU4, JU5, JU6 Jumper Setting**

JUMPER	SHUNT POSITION	DESCRIPTION
JU4	Installed*	SCL is pulled up to VCC
	Not installed	SCL is not pulled up to VCC
JU5	Installed*	SDA is pulled up to VCC
	Not installed	SDA is not pulled up to VCC
JU6	Installed*	$\overline{\text{INT}}$ is pulled up to VCC
	Not installed	$\overline{\text{INT}}$ is not pulled up to VCC

\*Default position.

**Table 3. JU12, JU13, JU14 Jumper Setting**

JUMPER	SHUNT POSITION	DESCRIPTION
JU12	Installed*	G_SNSR is connected to J4 pin 4
	Not installed	G_SNSR is not connected to J4 pin 4
JU13	Installed*	G_SNSL is connected to J4 pin 4
	Not installed	G_SNSL is not connected to J4 pin 4
JU14	Installed	Ground is connected to J4 pin 4
	Not installed*	Ground is not connected to J4 pin 4

\*Default position.

## Ordering Information

PART	TYPE
MAX20317EVKIT#	EVKIT

#Denotes RoHS compliant.

MAX20317 EV Kit Bill of Materials

ITEM	REF_DES	QTY	MFG PART #	MANUFACTURER	VALUE	DESCRIPTION
1	C1	1	GRM21BR61E475KA	MURATA	4.7UF	CAPACITOR; SMT (0805); CERAMIC CHIP; 4.7UF; 25V; TOL=10%; MODEL=; TG=55 DEGC TO +85 DEGC; TC=X6R;
2	C2, C3, C7	3	GRM21BR71C105KA01	MURATA	1UF	CAPACITOR; SMT (0805); CERAMIC CHIP; 1UF; 16V; TOL=10%; TG=55 DEGC TO +125 DEGC; TC=X7R
3	C4, C5	2	0603YD105KA1ZA	AVX	1UF	CAPACITOR; SMT (0603); CERAMIC CHIP; 1UF; 16V; TOL=10%; TG=55 DEGC TO +85 DEGC; TC=X6R
4	J1	1	AJR83-686010	ADVANCE CONNECTEK	AJR83-686010	EVKIT PART-CONNECTOR; AUDIO JACK; 3.5MM DIAMETER; SMT AND DIP
5	J2	1	61729-0010BLF	FCI CONNECT	61729-0010BLF	CONNECTOR; FEMALE; THROUGH-HOLE; UNIVERSAL SERIES BUS B-TYPE CONNECTOR; RIGHT ANGLE; 4PINS
6	J3	1	SBH11-PBPC-D20-ST-BK	SULLINS ELECTRONICS CORP.	SBH11-PBPC-D20-ST-BK	CONNECTOR; MALE; THROUGH HOLE; HEADER CONNECTOR; STRAIGHT; 40PINS; EDGE FOOTPRINT
7	J4	1	SJ-435107RS	CUI INC.	SJ-435107RS	CONNECTOR; FEMALE; THROUGH HOLE; SJ-435107 SERIES; 3.5 MM AUDIO JACK; RIGHT ANGLE; 6PINS
8	JU1, JU10	2	PEC03SAAN	SULLINS	PEC03SAAN	CONNECTOR; MALE; THROUGH HOLE; BREAKAWAY; STRAIGHT; 3PINS
9	JU5, JU6, JU12, JU14	7	PEC02SAAN	SULLINS	PEC02SAAN	CONNECTOR; MALE; THROUGH HOLE; BREAKAWAY; STRAIGHT; 2PINS
10	R1	1	CRCW08052K21FK	VISHAY DALE	2.21K	RESISTOR; 0805; 2.21K OHM; 1%; 100PPM; 0.125W; THICK FILM
11	R2	1	CRCW20106R80FKEFHP	VISHAY DRALORIC	6.8	RESISTOR; 2010; 6.8 OHM; 1%; 100PPM; 1W; THICK FILM
12	R3-R7, R11	6	CRCW06030000Z0	VISHAY DALE	0	RESISTOR; 0603; 0 OHM; 0%; JUMPER; 0.1W; THICK FILM
13	R8-R10	3	CRCW08053K92FK; MCR10EZHF3921	VISHAY DALE/ROHM	3.92K	RESISTOR; 0805; 3.92K OHM; 1%; 100PPM; 0.125W; THICK FILM
14	R12	1	CRCW08050000Z0EAHP	VISHAY DRALORIC	0	RESISTOR; 0805; 0 OHM; 0%; JUMPER; 0.5W; THICK FILM
15	SU1-SU9	9	STC02SYAN	SULLINS ELECTRONICS CORP.	STC02SYAN	TEST POINT; JUMPER; STR; TOTAL LENGTH=0.256IN; BLACK; INSULATION=PBT CONTACT=PHOSPHOR BRONZE; COPPER PLATED TIN OVERALL
16	TP1, TP8, TP13, TP16, TP22	7	5126	KEYSTONE	N/A	TEST POINT; PIN DIA=0.125IN; TOTAL LENGTH=0.446IN; BOARD HOLE=0.063IN; GREEN; PHOSPHOR BRONZE WIRE SILVER PLATE FINISH;
17	TP2, TP19, TP21, TP27	5	5013	KEYSTONE	N/A	TEST POINT; PIN DIA=0.125IN; TOTAL LENGTH=0.446IN; BOARD HOLE=0.063IN; ORANGE; PHOSPHOR BRONZE WIRE SILVER PLATE FINISH;
18	TP3	1	5129	KEYSTONE	N/A	TEST POINT; PIN DIA=0.125IN; TOTAL LENGTH=0.446IN; BOARD HOLE=0.063IN; PURPLE; PHOSPHOR BRONZE WIRE SILVER PLATE FINISH;
19	TP4, TP29	2	5128	KEYSTONE	N/A	TEST POINT; PIN DIA=0.125IN; TOTAL LENGTH=0.446IN; BOARD HOLE=0.063IN; GREY; PHOSPHOR BRONZE WIRE SILVER PLATE FINISH;
20	TP5, TP11, TP23, TP26	4	5010	KEYSTONE	N/A	TESTPOINT WITH 1.80MM HOLE DIA. RED, MULTIPURPOSE;
21	TP6	1	5014	KEYSTONE	N/A	TEST POINT; PIN DIA=0.125IN; TOTAL LENGTH=0.446IN; BOARD HOLE=0.063IN; YELLOW; PHOSPHOR BRONZE WIRE SILVER PLATE FINISH;
22	TP7, TP9, TP10, TP24, TP30, TP32	7	5011	KEYSTONE	N/A	TEST POINT; PIN DIA=0.125IN; TOTAL LENGTH=0.446IN; BOARD HOLE=0.063IN; BLACK; PHOSPHOR BRONZE WIRE SILVER PLATE FINISH;
23	TP12, TP28	2	5127	KEYSTONE	N/A	TEST POINT; PIN DIA=0.125IN; TOTAL LENGTH=0.446IN; BOARD HOLE=0.063IN; BLUE; PHOSPHOR BRONZE WIRE SILVER PLATE FINISH;
24	U1	1	MAX20317EWP+	MAXIM	MAX20317EWP+	EVKIT PART-IC; INF; UNIVERSAL 3.5 MM DIAMETER; ACCESSORY MANAGEMENT IC; PKG. OUTLINE DWG.: 21-100120A; PKG. CODE: W201H2+1
25	PCB	1	MAX	MAXIM	PCB	PCB:MAX
TOTAL		71				

MAX20317 EV Kit Schematics

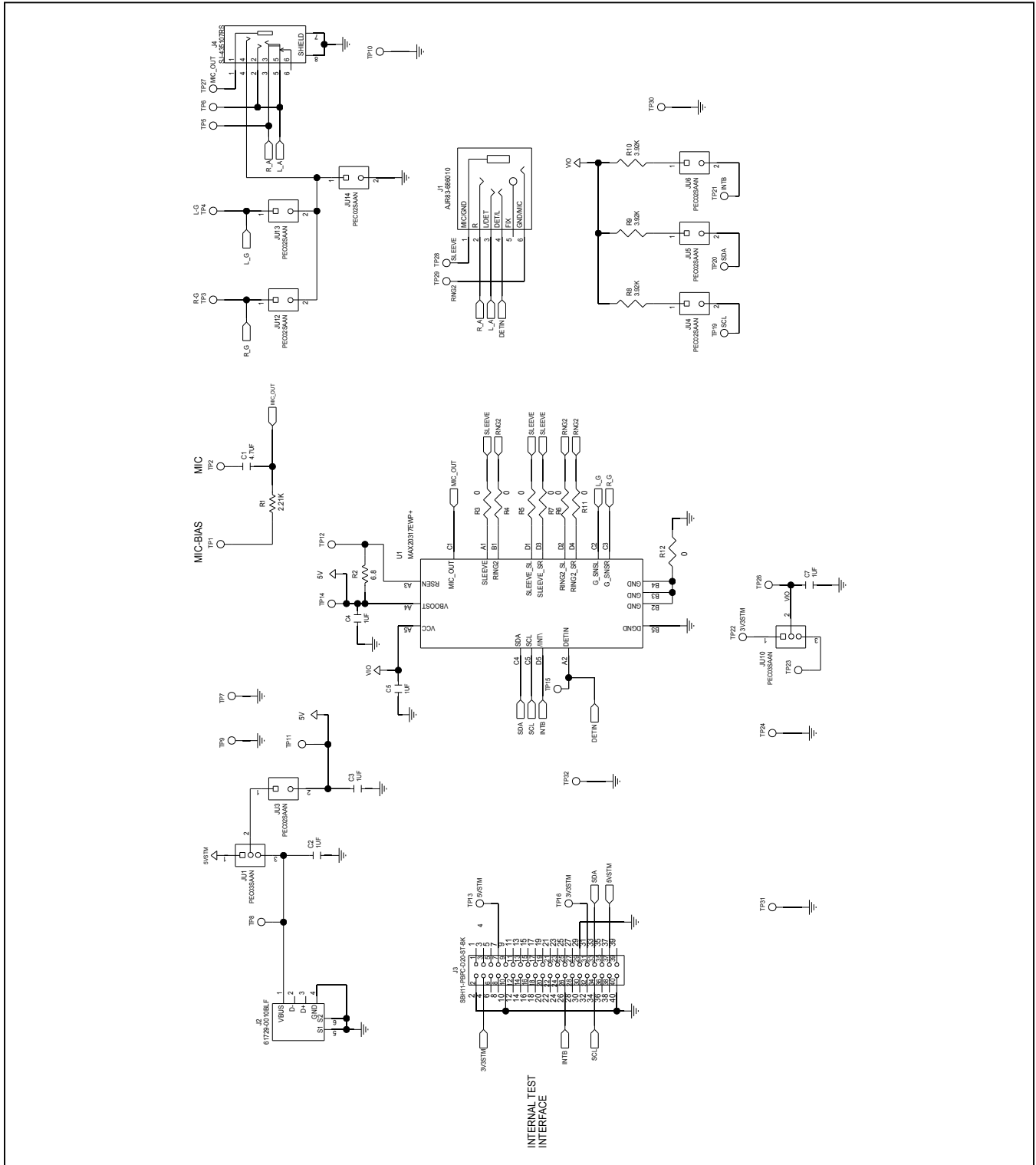

MAX20317 EV Kit PCB Layout Diagrams

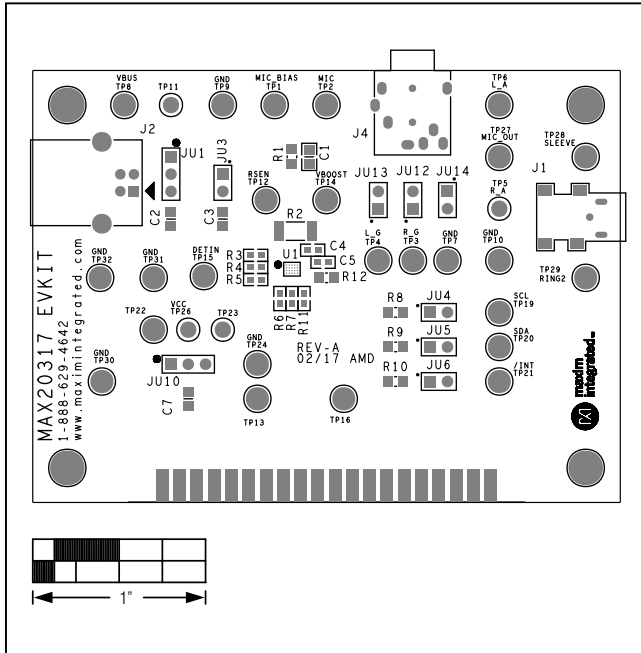

MAX20317 EV Kit—Top Silkscreen

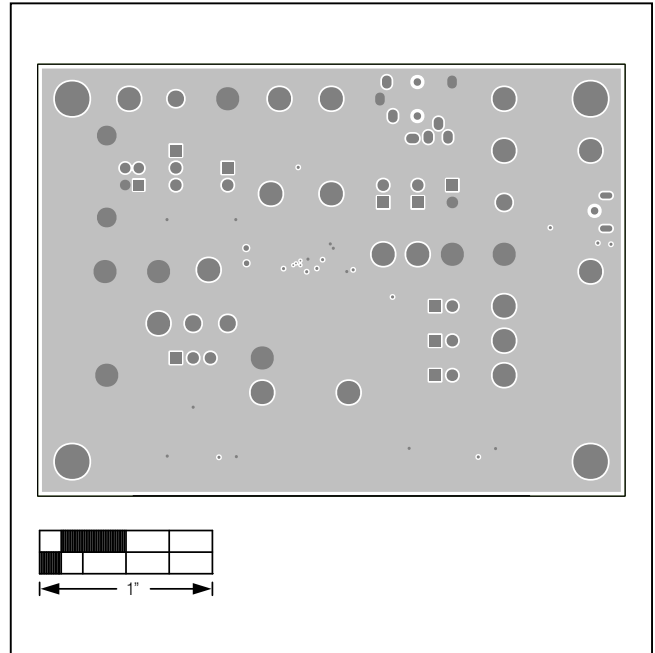

MAX20317 EV Kit—Layer 2

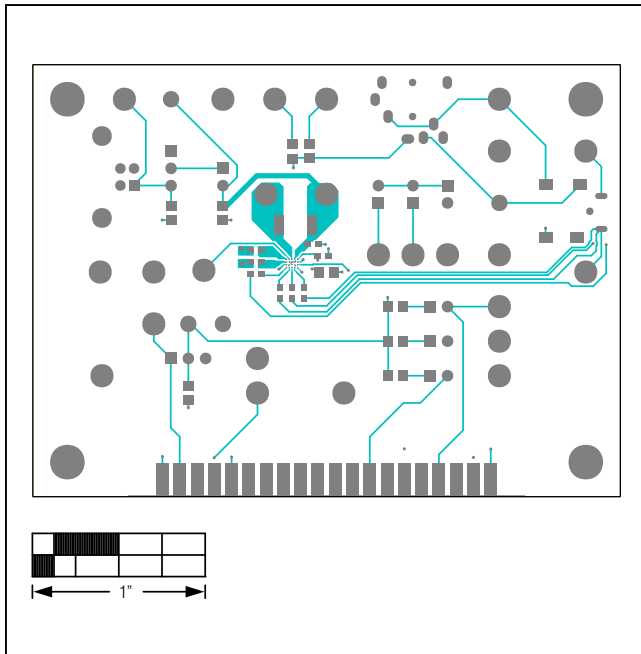

MAX20317 EV Kit—Top

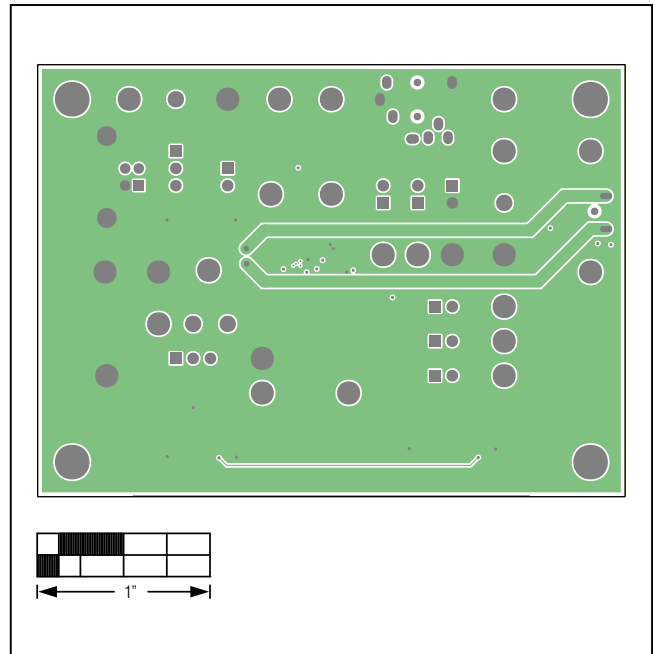

MAX20317 EV Kit—Layer 3

MAX20317 EV Kit PCB Layout Diagrams (continued)

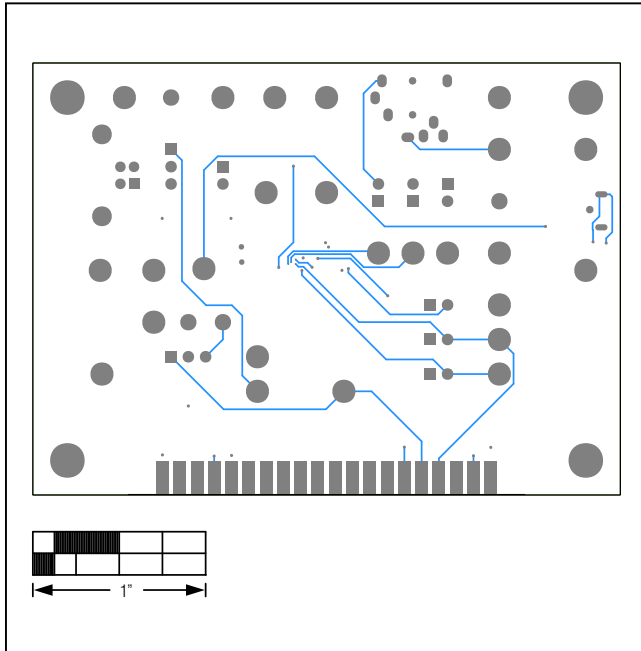

MAX20317 EV Kit—Bottom

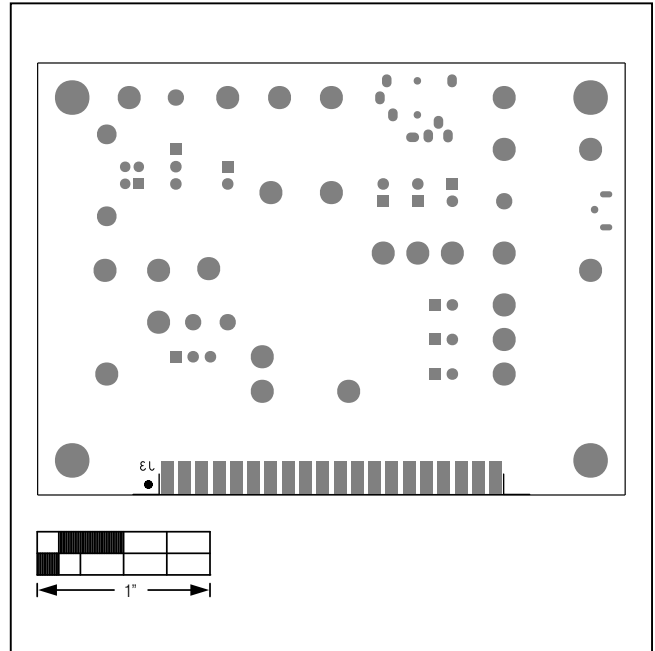

MAX20317 EV Kit— Bottom Silkscreen

### Revision History

REVISION NUMBER	REVISION DATE	DESCRIPTION	PAGES CHANGED
0	3/17	Initial release	—

For pricing, delivery, and ordering information, please contact Maxim Direct at 1-888-629-4642, or visit Maxim Integrated's website at [www.maximintegrated.com](http://www.maximintegrated.com).

*Maxim Integrated cannot assume responsibility for use of any circuitry other than circuitry entirely embodied in a Maxim Integrated product. No circuit patent licenses are implied. Maxim Integrated reserves the right to change the circuitry and specifications without notice at any time.*

## X-ON Electronics

Largest Supplier of Electrical and Electronic Components

*Click to view similar products for [Power Management IC Development Tools](#) category:*

*Click to view products by [Maxim](#) manufacturer:*

Other Similar products are found below :

[EVB-EP5348UI](#) [MIC23451-AAAYFL EV](#) [MIC5281YMME EV](#) [124352-HMC860LP3E](#) [DA9063-EVAL](#) [ADP122-3.3-EVALZ](#) [ADP130-0.8-EVALZ](#) [ADP130-1.8-EVALZ](#) [ADP1740-1.5-EVALZ](#) [ADP1870-0.3-EVALZ](#) [ADP1874-0.3-EVALZ](#) [ADP199CB-EVALZ](#) [ADP2102-1.25-EVALZ](#) [ADP2102-1.875EVALZ](#) [ADP2102-1.8-EVALZ](#) [ADP2102-2-EVALZ](#) [ADP2102-3-EVALZ](#) [ADP2102-4-EVALZ](#) [AS3606-DB](#) [BQ25010EVM](#) [BQ3055EVM](#) [ISLUSBI2CKIT1Z](#) [LP38512TS-1.8EV](#) [EVAL-ADM1186-1MBZ](#) [EVAL-ADM1186-2MBZ](#) [ADP122UJZ-REDYKIT](#) [ADP166Z-REDYKIT](#) [ADP170-1.8-EVALZ](#) [ADP171-EVALZ](#) [ADP1853-EVALZ](#) [ADP1873-0.3-EVALZ](#) [ADP198CP-EVALZ](#) [ADP2102-1.0-EVALZ](#) [ADP2102-1-EVALZ](#) [ADP2107-1.8-EVALZ](#) [ADP5020CP-EVALZ](#) [CC-ACC-DBMX-51](#) [ATPL230A-EK](#) [MIC23250-S4YMT EV](#) [MIC26603YJL EV](#) [MIC33050-SYHL EV](#) [TPS60100EVM-131](#) [TPS65010EVM-230](#) [TPS71933-28EVM-213](#) [TPS72728YFFEVM-407](#) [TPS79318YEQEVM](#) [UCC28810EVM-002](#) [XILINXPWR-083](#) [LMR22007YMINI-EVM](#) [LP38501ATJ-EV](#)