

## MAX20414 Evaluation Kit

Evaluates: MAX20414

### General Description

The MAX20414 evaluation kit (EV kit) is a fully assembled and tested PCB that demonstrates the MAX20414 power-management IC (PMIC). The EV kits include two high-efficiency, low-voltage DC-DC converters. OUT1 boosts a 3.3V input to 5V at up to 500mA, while the OUT2 step-down converter provides adjustable output voltages down to 0.8V at up to 3A. The 2.2MHz switching-frequency operation allows for the use of all-ceramic capacitors and minimizes external components.

The EV kit features two on/off jumper controls and two reset outputs ( $\overline{\text{RESET1}}$ ,  $\overline{\text{RESET2}}$ ) to indicate output status for each converter. It also provides a SYNC input to select the operating mode (forced-PWM, skip, or external frequency synchronization).

### Features

- 3V to 5.5V Operating Supply Voltage
- 5V at 500mA Synchronous Boost Converter (OUT1)
- 1.25V at 3A Synchronous Buck Converter (OUT2)
- SYNC Mode Select Input for Forced-PWM (FPWM), Skip Mode Selection, or External Frequency Synchronization
- Individual  $\overline{\text{RESET}}$  Outputs
- Minimized External Components
- Proven PCB Layout
- Fully Assembled and Tested

### Quick Start

#### Required Equipment

- MAX20414 EV kit
- Variable 6V power supply capable of supplying 5A
- Two voltmeters
- Electronic load

**Ordering Information** appears at end of data sheet.

### Procedure

The EV kit is fully assembled and tested. Follow the steps below to verify board operation. **Caution: Do not turn on the power supply until all connections are completed.**

- 1) Preset the power supply to 3.3V. Turn off the power supply.
- 2) Preset the electronic load to 500mA. Turn off the electronic load.
- 3) Connect the positive lead of the power supply to the VSUP PCB pad. Connect the negative lead of the power supply to the PGND PCB pad.
- 4) Connect the positive terminal of the electronic load to the VOUT1 PCB pad. Connect the negative terminal of the electronic load to the PGND1 PCB pad.
- 5) Enable outputs VOUT1 and VOUT2 by installing shunts on jumpers EN1 and EN2.
- 6) Install a shunt on SYNC1 to enable FPWM operation.
- 7) Turn on the power supply.
- 8) Verify that the voltage across the VOUT1 and PGND1 PCB pads is  $5V \pm 1\%$ .
- 9) Verify that the voltage across the  $\overline{\text{RESET1}}$  and PGND PCB pads is 3.3V.
- 10) Turn on the electronic load.
- 11) Verify that the voltage across the VOUT1 and PGND1 PCB pads is  $5V \pm 2\%$ .
- 12) Turn off the electronic load.
- 13) Remove the electronic load from the VOUT1 and PGND1 PCB pads.
- 14) Connect the positive terminal of the electronic load to the VOUT2 PCB pad. Connect the negative terminal of the electronic load to the PGND2 PCB pad. Preset the electronic load to 3A.
- 15) Verify that the voltage across the VOUT2 and PGND2 PCB pads is  $1.25V \pm 2\%$ .
- 16) Verify that the voltage across the  $\overline{\text{RESET2}}$  and PGND PCB pads is 3.3V.
- 17) Turn on the electronic load.
- 18) Verify that the voltage across the VOUT2 and PGND2 PCB pads is  $1.25V \pm 3\%$ .
- 19) Turn off the electronic load.
- 20) Turn off the power supply.

### Detailed Description

The MAX20414 EV kit integrates two high-efficiency, low-voltage DC-DC converters. OUT1 is a synchronous boost converter that boosts a 3.3V input to 5V at up to 500mA, while the OUT2 synchronous step-down converter provides adjustable output voltages down to 0.8V at up to 3A.

V<sub>OUT1</sub> and V<sub>OUT2</sub> can be enabled/disabled by the EN1 and EN2 jumpers, respectively. The status of input voltage and output voltages can be indicated by RESET1 and RESET2.

#### Adjustable Buck Output Voltage (V<sub>OUT2</sub>)

The buck output voltage (V<sub>OUT2</sub>) can be adjusted using the following procedure:

- 1) Choose R<sub>BOTTOM</sub> to be 100kΩ or less.
- 2) Solve for R<sub>TOP</sub> using:  
 $R_{TOP} = R_{BOTTOM} \times [(V_{OUT\_}/0.8V) - 1]$
- 3) Install resistors R<sub>TOP</sub> and R<sub>BOTTOM</sub>. R<sub>TOP</sub> refers to R2, while R<sub>BOTTOM</sub> refers to R3 in the EV kit schematic.

#### Operation Mode

The EV kit features a jumper (SYNC1) to configure the IC's operation mode. Install a shunt on SYNC1 to enter FPWM mode. Remove the shunt on SYNC1 to enable skip mode under light-load conditions. Connect an external clock with a 1.8MHz to 2.6MHz frequency to synchronize the internal oscillator to an external clock.

Table 1 summarizes the functions of SYNC1.

#### Enable Control

The EN1, and EN2 jumpers are used to enable or disable V<sub>OUT1</sub>, and V<sub>OUT2</sub>, respectively. Install shunts on EN1, or EN2 to enable V<sub>OUT1</sub> or V<sub>OUT2</sub> normal operation. Remove the shunts on EN1 or EN2 to enter shutdown mode. See Table 2 for enable control

### Reset Outputs (RESET1 and RESET2)

The EV kit also includes two RESET<sub>1</sub> and RESET<sub>2</sub> outputs to monitor V<sub>OUT1</sub> and V<sub>OUT2</sub> output status. The RESET<sub>1</sub> output becomes high impedance and is pulled to the VSUP voltage when the corresponding output voltage is within the specified UV/OV range. RESET<sub>1</sub> goes low when the corresponding output voltage is not within the specified UV/OV range.

Table 1. Operation Mode (SYNC1)

SHUNT POSITION	MODE
On	Forced PWM
Off	Skip
Off (an external clock connected to the SYNC PCB pad)	Synchronize to external clock

Table 2. Enable Control (EN1, and EN2)

SHUNT POSITION	MODE
On	Normal Operation
Off	Shutdown

### Ordering Information

PART	TYPE
MAX20414EVKIT#	EV Kit

#Denotes RoHS compliant.

## MAX20414 EV Kit Bill of Materials

DESIGNATION	QTY	DESCRIPTION
C1	1	10 $\mu$ F 16V X6S Ceramic Capacitor (0805)
		Murata GRT21BC81C106KE01L
C2	1	47 $\mu$ F 4V X6S Ceramic Capacitor (0805)
		Murata GRT21BC80G476ME13L
C4	1	47 $\mu$ F 16V Aluminum Capacitor
		Panasonic EEEFC1C470P
C5	1	4.7 $\mu$ F 16V X7R Ceramic Capacitor (1206)
		TDK CGA5L3X7R1C475K160AB
C7	1	1 $\mu$ F 16V X7R Ceramic Capacitor (0603)
		TDK C1608X7R1C105K080AC
C8	1	0.33 $\mu$ F 16V X7R Ceramic Capacitor (0603)
		TDK C1608X7R1C334K080AC
C11	1	4.7 $\mu$ F 16V X6S Ceramic Capacitor (0603)
		Murata GRT188C81C475ME13D
C12	1	0 $\Omega$ 1% Resistor (0603)
C13	1	18pF 50V COG Ceramic Capacitor (0603)
		TDK CGA3E2C0G1H180J080AA
C14	0	Not Installed (0805)
EN1, EN2, SYNC1, WDS	4	2-Pin Header 0.1"
		Sullins: PEC36SAAN or Equivalent
		(36 PIN STRIP, CUT TO SIZE AS NEEDED)
L1	1	2.2 $\mu$ H Inductor
		TDK TFM252012ALMB2R2MTAA
L2	1	0.47 $\mu$ H Inductor
		TDK TFM252010ALMBR47MTAA
R1	1	10 $\Omega$ 1% Resistor (0603)
R2	1	11.3k $\Omega$ 1% Resistor (0603)
R3, R10, R11	3	20k $\Omega$ 1% Resistor (0603)
R4, R12	2	0 $\Omega$ 1% Resistor (0603)
R8	0	Not Installed (0603)
U1	1	2.2MHz Sync Boost and Dual Step-Down Converter PMIC
		Maxim MAX20414ATGA/V+ (24 TQFN 4mm $\times$ 4mm $\times$ 0.75mm)
---	4	Shunt, 2 POSITION
		Sullins: STC02SYAN or Equivalent
---	1	PCB: MAX20414 EVKIT

MAX20414 EV Kit Schematic

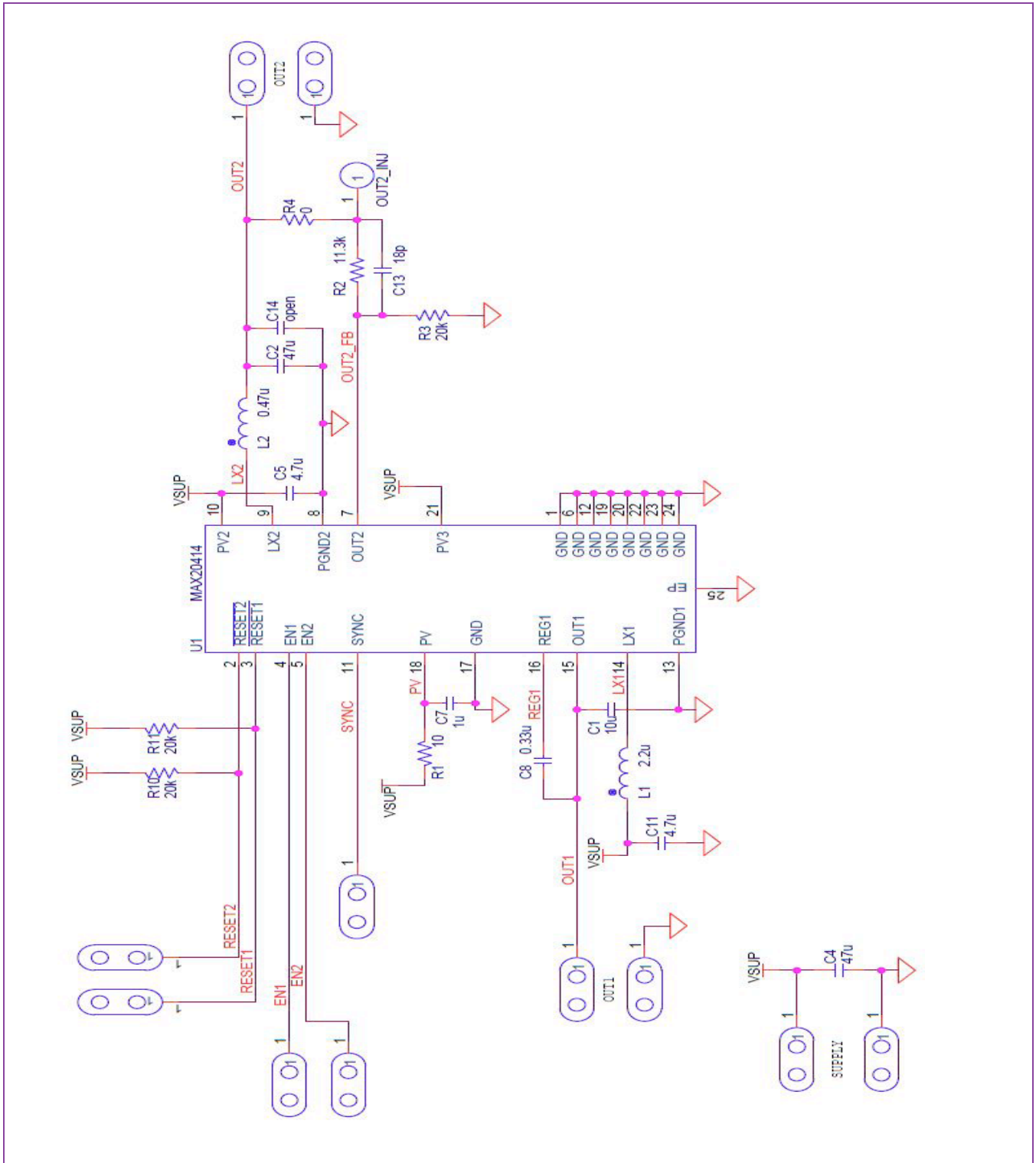

MAX20414 EV Kit Layout Diagrams

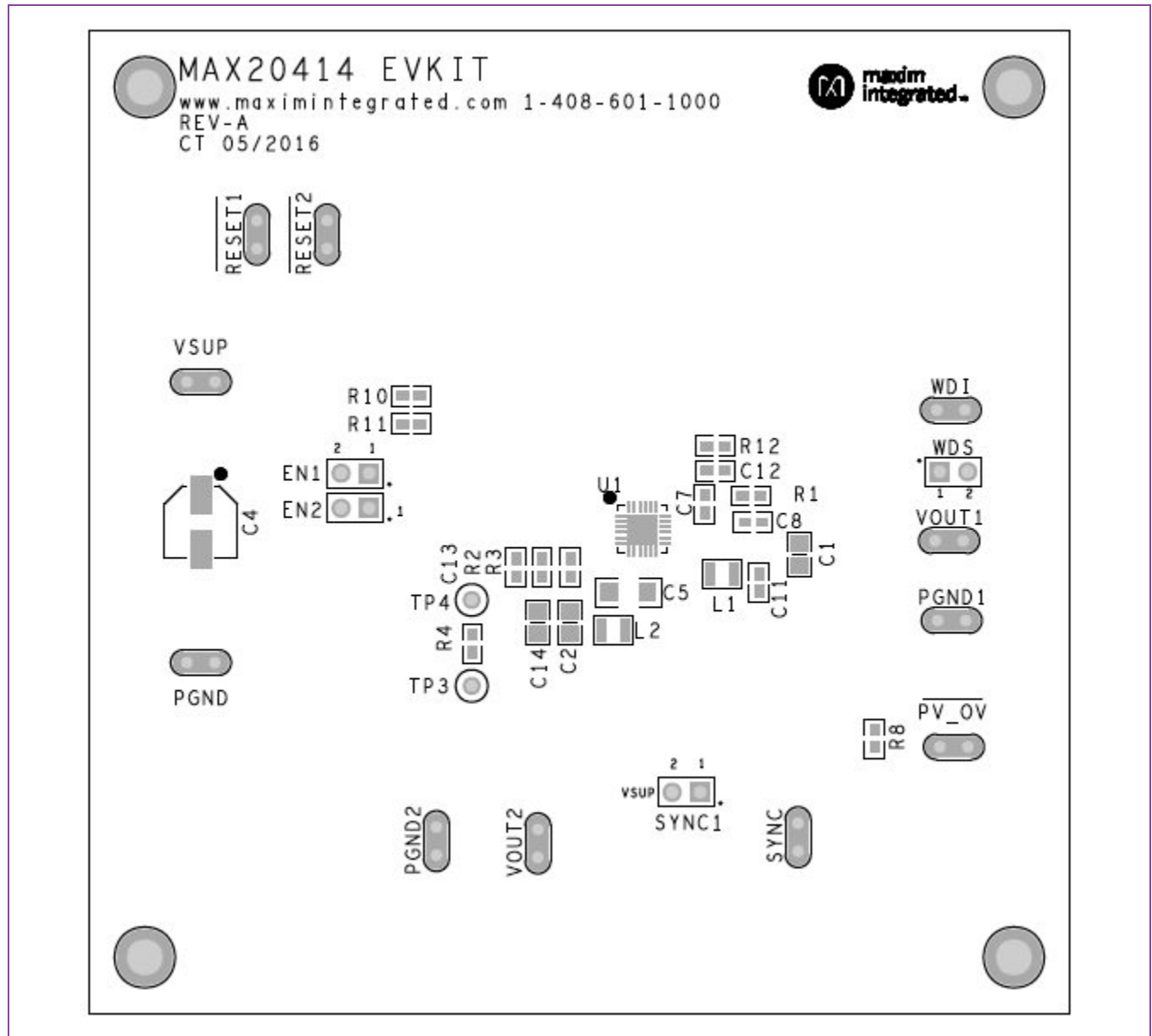

MAX20414 EV Kit Schematic Component Placement Guide—Top Silkscreen

MAX20414 EV Kit Layout Diagrams (continued)

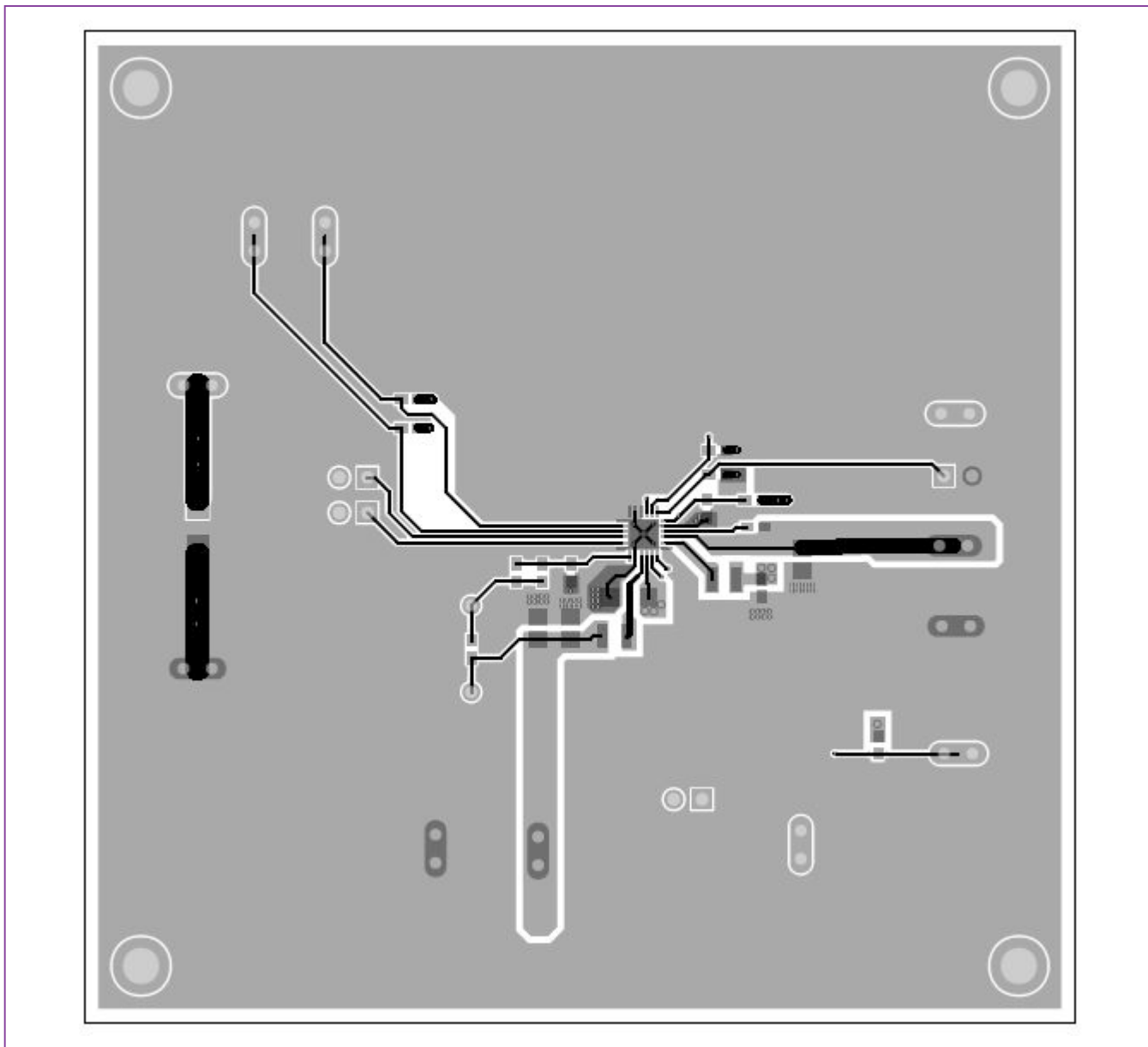

MAX20414 EV Kit Schematic PCB Layout—Top Layer

MAX20414 EV Kit Layout Diagrams (continued)

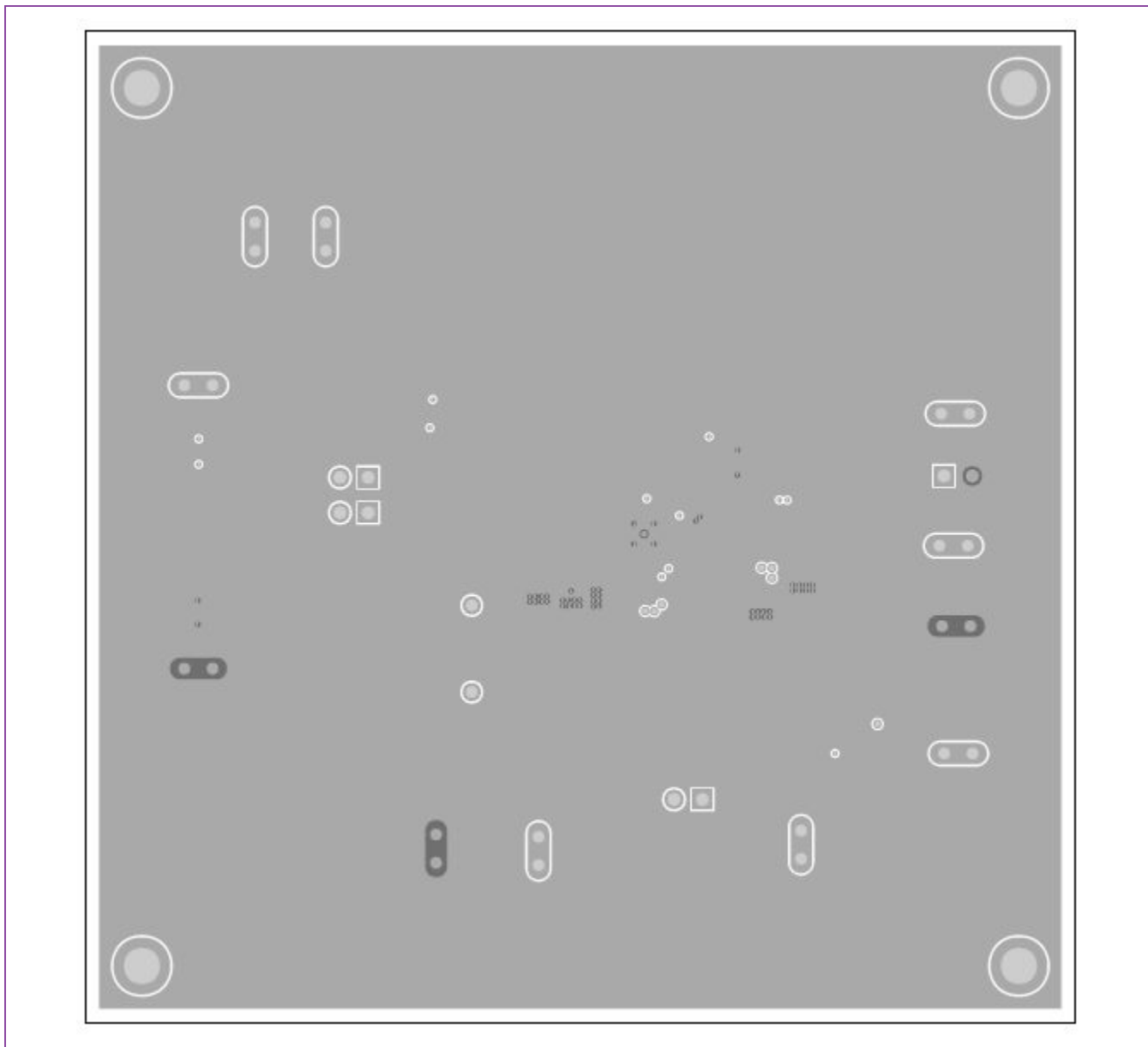

MAX20414 EV Kit Schematic PCB Layout—Internal Layer 2

MAX20414 EV Kit Layout Diagrams (continued)

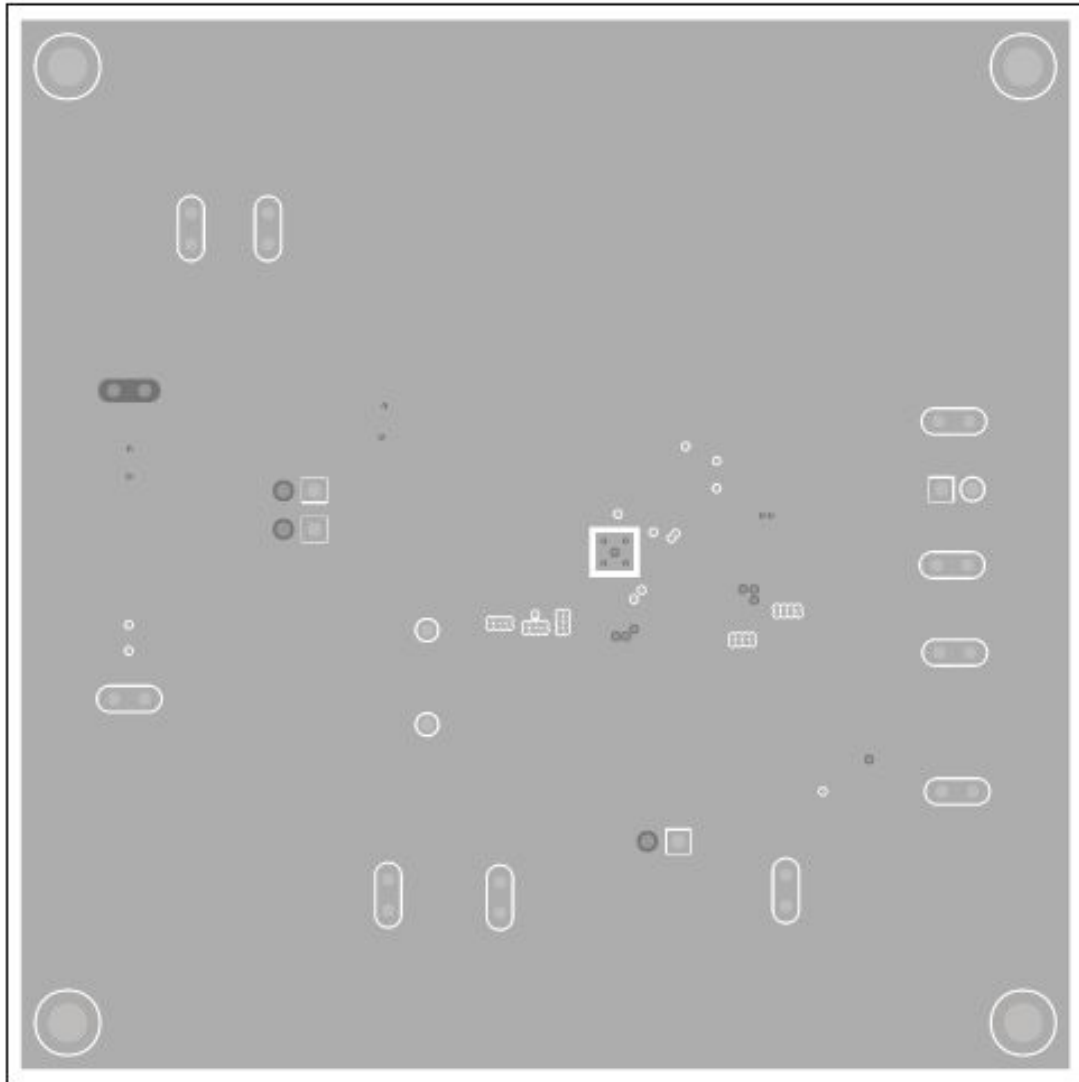

MAX20414 EV Kit Schematic PCB Layout—Internal Layer 3



MAX20414 EV Kit Layout Diagrams (continued)

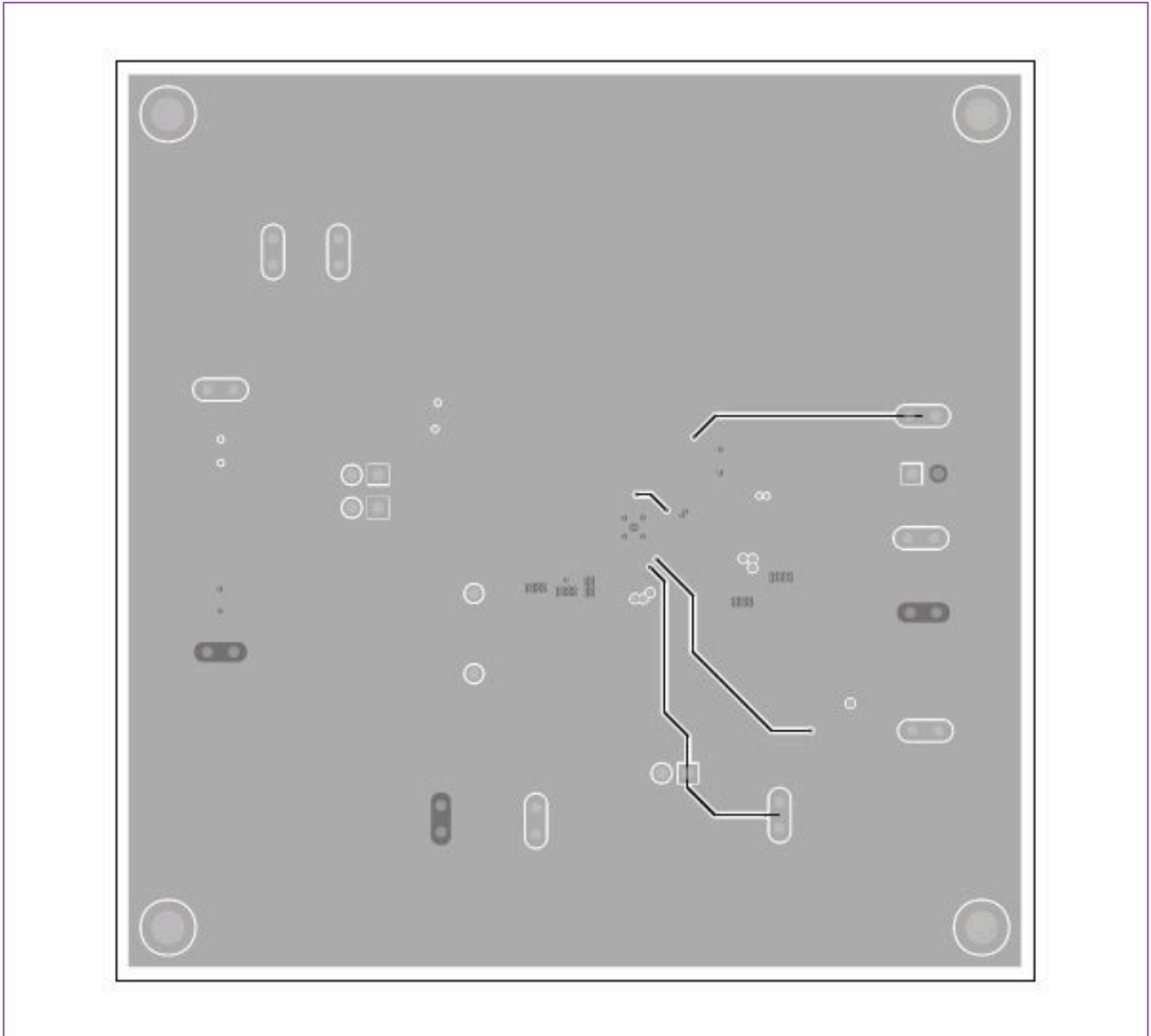

MAX20414 EV Kit Schematic PCB Layout—Bottom Layer

## Revision History

REVISION NUMBER	REVISION DATE	DESCRIPTION	PAGES CHANGED
0	5/17	Initial release	—
0.1	5/18	Corrected typo with root part number in <a href="#">Ordering Information</a> (changed from MAX200414 to MAX20414)	2

For pricing, delivery, and ordering information, please contact Maxim Direct at 1-888-629-4642, or visit Maxim Integrated's website at [www.maximintegrated.com](http://www.maximintegrated.com).

*Maxim Integrated cannot assume responsibility for use of any circuitry other than circuitry entirely embodied in a Maxim Integrated product. No circuit patent licenses are implied. Maxim Integrated reserves the right to change the circuitry and specifications without notice at any time.*

## X-ON Electronics

Largest Supplier of Electrical and Electronic Components

*Click to view similar products for [Power Management IC Development Tools](#) category:*

*Click to view products by [Maxim](#) manufacturer:*

Other Similar products are found below :

[EVAL-ADM1168LQEBZ](#) [EVB-EP5348UI](#) [MIC23451-AAAYFL EV](#) [MIC5281YMME EV](#) [DA9063-EVAL](#) [ADP122-3.3-EVALZ](#) [ADP130-0.8-EVALZ](#) [ADP130-1.2-EVALZ](#) [ADP130-1.5-EVALZ](#) [ADP130-1.8-EVALZ](#) [ADP1712-3.3-EVALZ](#) [ADP1714-3.3-EVALZ](#) [ADP1715-3.3-EVALZ](#) [ADP1716-2.5-EVALZ](#) [ADP1740-1.5-EVALZ](#) [ADP1752-1.5-EVALZ](#) [ADP1828LC-EVALZ](#) [ADP1870-0.3-EVALZ](#) [ADP1871-0.6-EVALZ](#) [ADP1873-0.6-EVALZ](#) [ADP1874-0.3-EVALZ](#) [ADP1882-1.0-EVALZ](#) [ADP199CB-EVALZ](#) [ADP2102-1.25-EVALZ](#) [ADP2102-1.875EVALZ](#) [ADP2102-1.8-EVALZ](#) [ADP2102-2-EVALZ](#) [ADP2102-3-EVALZ](#) [ADP2102-4-EVALZ](#) [ADP2106-1.8-EVALZ](#) [ADP2147CB-110EVALZ](#) [AS3606-DB](#) [BQ24010EVM](#) [BQ24075TEVM](#) [BQ24155EVM](#) [BQ24157EVM-697](#) [BQ24160EVM-742](#) [BQ24296MEVM-655](#) [BQ25010EVM](#) [BQ3055EVM](#) [NCV891330PD50GEVB](#) [ISLUSBI2CKIT1Z](#) [LM2744EVAL](#) [LM2854EVAL](#) [LM3658SD-AEV/NOPB](#) [LM3658SDEV/NOPB](#) [LM3691TL-1.8EV/NOPB](#) [LM4510SDEV/NOPB](#) [LM5033SD-EVAL](#) [LP38512TS-1.8EV](#)