

MAX20416 Evaluation Kit

Evaluates: MAX20416

General Description

The MAX20416 evaluation kit (EV kit) is a fully assembled and tested PCB that demonstrates the MAX20416 power-management IC (PMIC). The EV kit includes two high-efficiency, low-voltage DC-DC synchronous buck converters (OUT1, OUT2) that operate from a 3.0V to 5.5V input voltage range and provide a 0.8V to 3.8V output voltage range at up to 3A. The 2.2MHz switching-frequency operation allows for the use of all-ceramic capacitors and minimizes external components.

The EV kit features two on/off jumper controls and two reset outputs to indicate output status for each converter. The EV kit also provides a SYNC input to select the operating mode (PWM, skip, or external synchronization).

Benefits and Features

- 3.0V to 5.5V Operating Supply Voltage
- 1.25V at 3A Synchronous Buck Converter (OUT1)
- 1.8V at 3A Synchronous Buck Converter (OUT2)
- Sync-Mode Select, Input for Forced-PWM (FPWM), Skip-Mode Selection, or External Frequency Synchronization
- Individual EN Inputs and RESET_ Outputs
- Minimized External Components
- Proven PCB Layout
- Fully Assembled and Tested

Quick Start

Required Equipment

- Variable 6V power supply capable of supplying 5A
- Two voltmeters
- Electronic load

[Ordering Information](#) appears at end of data sheet.

Procedure

The MAX20416 EV kit is fully assembled and tested. Follow the steps below to verify board operation. **Caution: Do not turn on the power supply until all connections are completed.**

- 1) Preset the power supply to 3.3V. Turn the power supply.
- 2) Preset the electronic load to 3A. Turn the electronic load.
- 3) Connect the positive lead of the power supply to the VSUP PCB pad. Connect the negative lead of the power supply to the PGND PCB pad.
- 4) Connect the positive terminal of the electronic load to the VOUT1 PCB pad. Connect the negative terminal of the electronic load to the PGND1 PCB pad.
- 5) Enable outputs OUT1 and OUT2 by installing shunts across jumpers EN1 and EN2.
- 6) Install a shunt on SYNC1 to enable FPWM operation.
- 7) Turn on the power supply.
- 8) Verify that voltage across the VOUT1 and PGND1 PCB pads is $1.25V \pm 2\%$.
- 9) Verify that voltage across the $\overline{\text{RESET1}}$ and PGND PCB pads is 3.3V.
- 10) Turn on the electronic load.
- 11) Verify that voltage across the VOUT1 and PGND1 PCB pads is $1.25V \pm 2\%$.
- 12) T
- 13) Remove the electronic load from the VOUT1 and PGND1 PCB pads.
- 14) Connect the positive terminal of the electronic load to the VOUT2 PCB pad. Connect the negative terminal of the electronic load to the PGND2 PCB pad. Preset the electronic load to 3A.
- 15) Verify that voltage across the VOUT2 and PGND2 PCB pads is $1.8V \pm 2\%$.
- 16) Verify that voltage across the $\overline{\text{RESET2}}$ and PGND PCB pads is 3.3V.
- 17) Turn on the electronic load.
- 18) Verify that voltage across the VOUT2 and PGND2 PCB pads is $1.8V \pm 3\%$.
- 19) T
- 20) T

Detailed Description

The MAX20416 EV kit integrates two high-efficiency, low-voltage DC-DC converters (OUT1, OUT2) that provide adjustable output voltages from 0.8V to 3.8V at up to 3A. V_{OUT1} and V_{OUT2} can be enabled/disabled by EN1, and EN2 jumpers respectively. The status of input voltage and output voltages can be indicated by RESET1 and RESET2.

Adjustable Buck Output Voltage (V_{OUT1} and V_{OUT2})

The buck outputs (V_{OUT1} and V_{OUT2}) can be adjustable using the following procedure:

- 1) Choose R_{BOTTOM} to be 100kΩ or less.
- 2) Solve for R_{TOP} using:

$$R_{TOP} = R_{BOTTOM} \times [(V_{OUT_} / 0.8V) - 1]$$
- 3) Install resistors R_{TOP} and R_{BOTTOM} . R_{TOP} refers to R4/R6, while R_{BOTTOM} refers to R3/R5 in the EV kit schematic.

Operation Mode

The EV kit features a jumper (SYNC1) to configure the IC's operation mode. Install a shunt on SYNC1 to enter FPWM mode. Remove the shunt on SYNC1 to enable skip mode under light-load conditions. Connect an external clock with frequency in the range of 1.8MHz to 2.6MHz to synchronize the internal oscillator to an external clock. [Table 1](#) summarizes the functions of SYNC1.

Enable Control Inputs (EN1, EN2)

The EN1 and EN2 jumpers are used to enable or disable V_{OUT1} and V_{OUT2} , respectively. Install shunts on EN1, or EN2 to enable V_{OUT1} , or V_{OUT2} normal operation. Remove shunts on EN1 or EN2 to enter shutdown mode. See [Table 2](#) for enable control

Reset Outputs ($\overline{RESET1}$, $\overline{RESET2}$)

The EV kits also include two $\overline{RESET_}$ outputs to monitor the V_{OUT1} and V_{OUT2} output status. The $\overline{RESET_}$ output becomes high impedance and is pulled to the VSUP voltage when the corresponding output voltage is within the _____ undervoltage/overvoltage (UV/OV) range. $\overline{RESET_}$ goes low when the corresponding output voltage is not within the _____ UV/OV range.

Table 1. Operation Mode (SYNC1)

SHUNT POSITION	MODE
On	FPWM
	Skip
SYNC1 PCB pad)	Synchronize to external clock

Table 2. Enable Control (EN1, EN2)

SHUNT POSITION	MODE
ON	Normal Operation
OFF	Shutdown

Ordering Information

PART	TYPE
MAX20416EVKIT#	EV Kit

#Denotes RoHS compliant.

MAX20416 EV Kit Bill of Materials

DESIGNATION	QTY	DESCRIPTION
C2, C3	2	47 μ F 4V X6S Ceramic Capacitor (0805)
		Murata GRT21BC80G476ME13L
C4	1	47 μ F 16V Aluminum Capacitor
		Panasonic EEEFC1C470P
C5, C6	2	4.7 μ F 16V X7R Ceramic Capacitor (1206)
		TDK CGA5L3X7R1C475K160AB
C7	1	1 μ F 16V X7R Ceramic Capacitor (0603)
		TDK C1608X7R1C105K080AC
C9	1	8pF 50V C0G Ceramic Capacitor (0603)
		TDK CGA3E2C0G1H080D080AA
C10, C14	0	Not Installed (0805)
C12	1	0 Ω 1% Resistor (0603)
C13	1	18pF 50V COG Ceramic Capacitor (0603)
		TDK CGA3E2C0G1H180J080AA
EN1, EN2, SYNC1, WDS	4	2-Pin Header 0.1"
		Sullins: PEC36SAAN or Equivalent
		(36 PIN STRIP, CUT TO SIZE AS NEEDED)
L2, L3	2	0.47 μ H Inductor
		TDK TFM252010ALMBR47MTAA
R1	1	10 Ω 1% Resistor (0603)
R2	1	11.3k Ω 1% Resistor (0603)
R3, R5, R9, R10	4	20k Ω 1% Resistor (0603)
R4, R7, R12	3	0 Ω 1% Resistor (0603)
R6	1	24.9k Ω 1% Resistor (0603)
R8	0	Not Installed (0603)
U1	1	2.2MHz Sync Boost and Dual Step-Down Converter PMIC
		Maxim MAX20416ATGA/V+ (TQFN 4mm \times 4mm \times 0.75mm)
—	4	Shunt, 2 POSITION
		Sullins: STC02SYAN or Equivalent
—	1	PCB: MAX20416 EVKIT

MAX20416 EV Kit Schematic

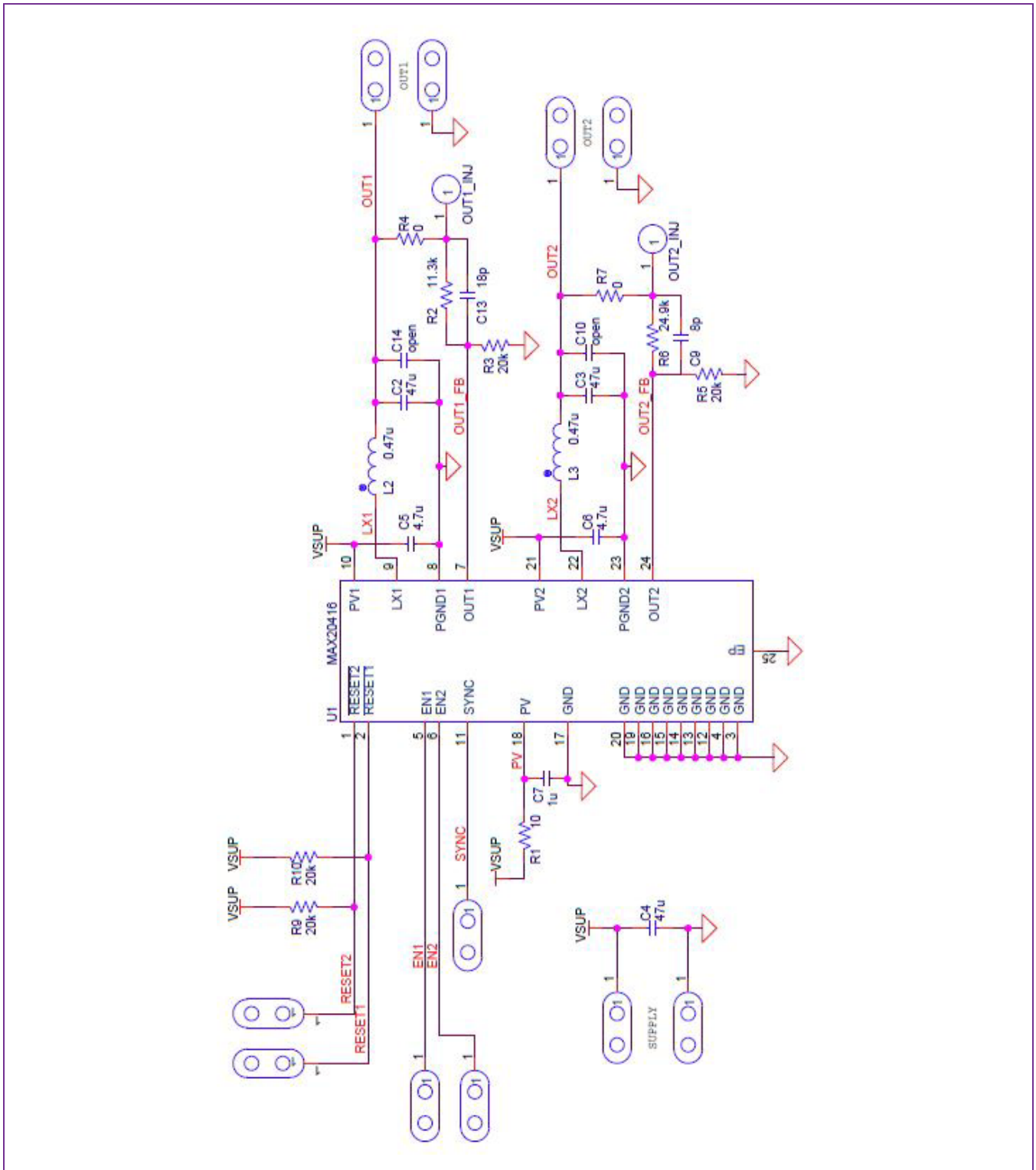

MAX20416 EV Kit PCB Layouts

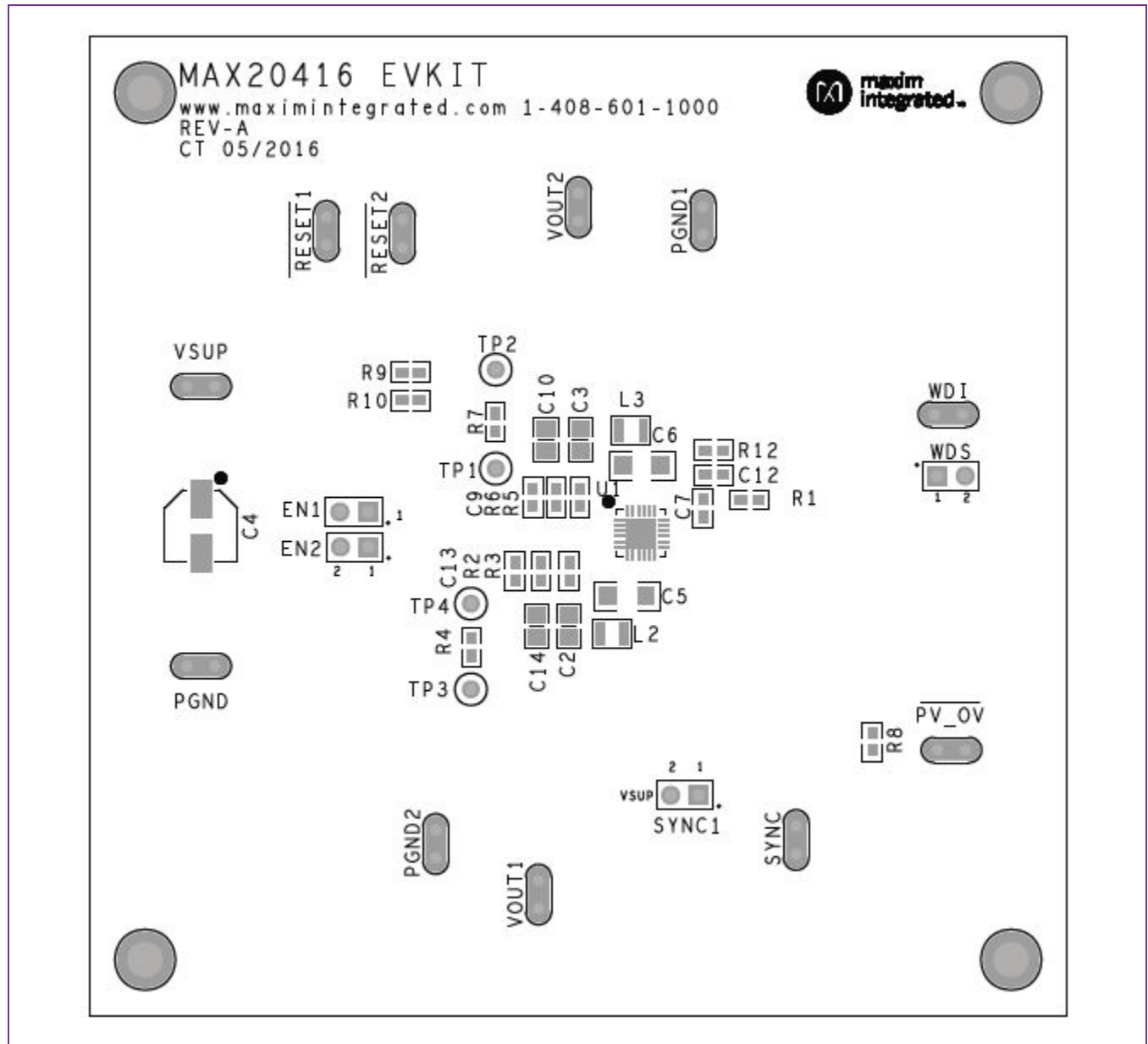

MAX20416 EV Kit Component Placement Guide—Top Silkscreen

MAX20416 EV Kit PCB Layouts (continued)

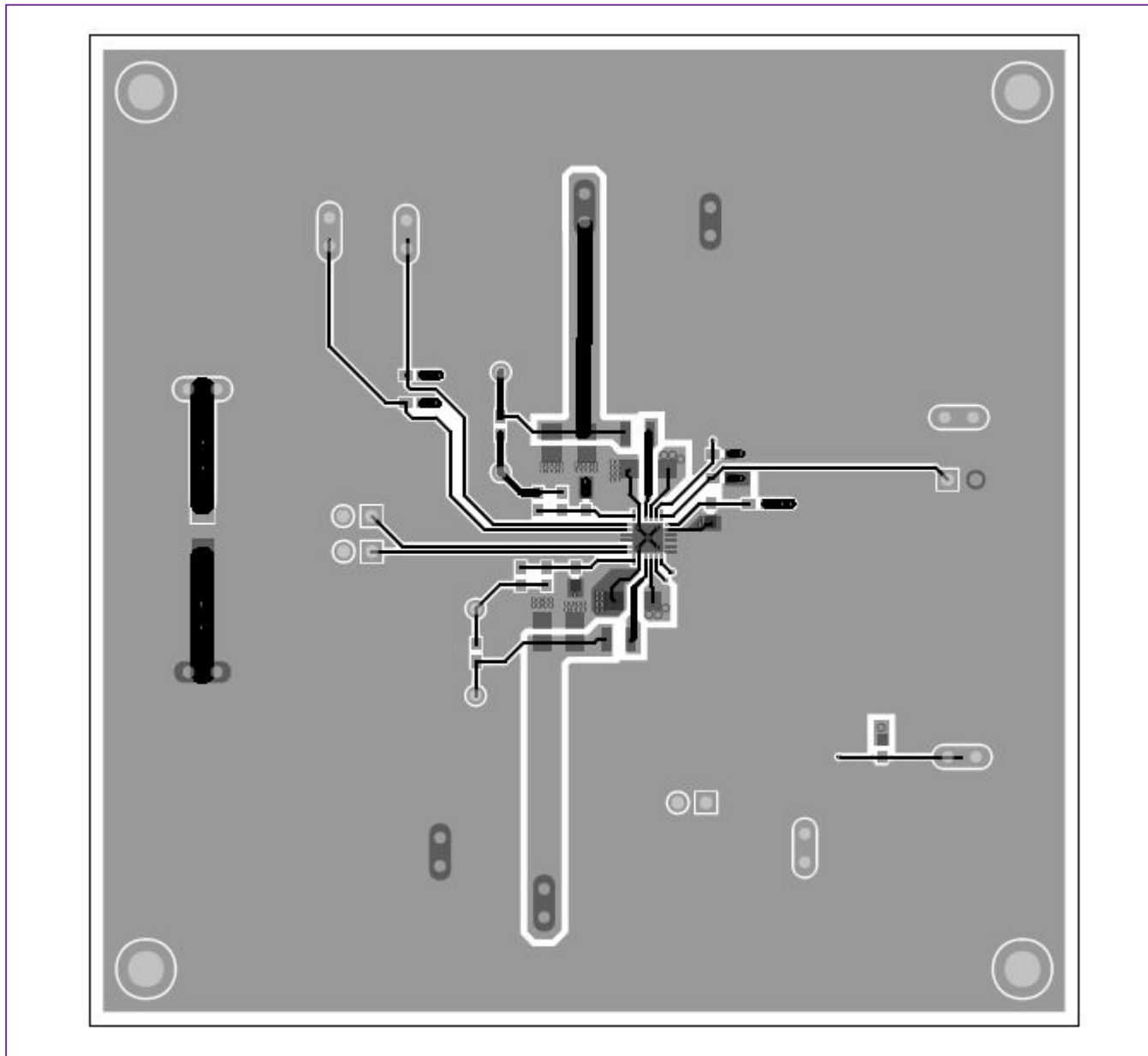

MAX20416 EV Kit PCB Layout—Top Layer

MAX20416 EV Kit PCB Layouts (continued)

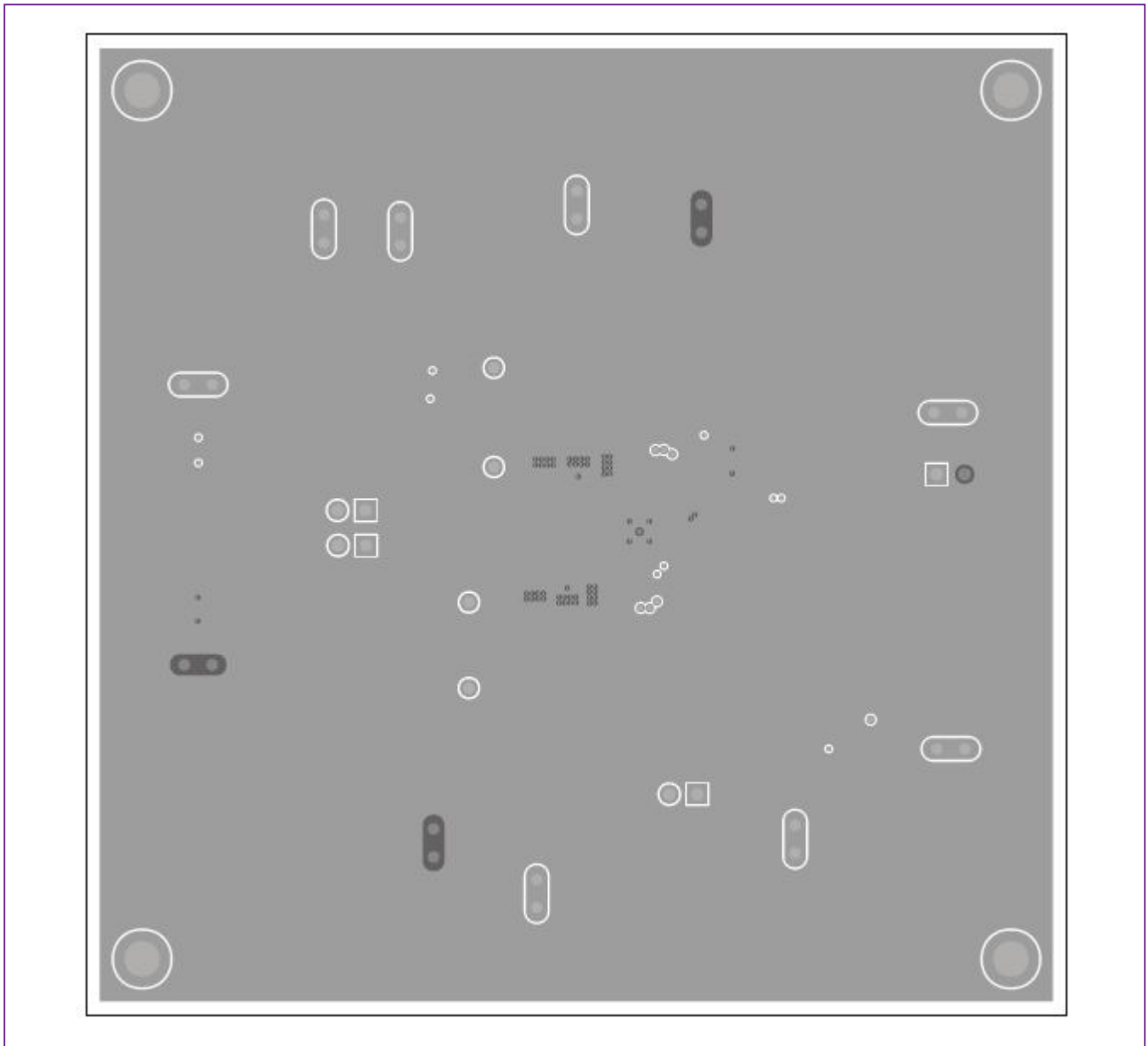

MAX20416 EV Kit PCB Layout—Internal Layer 2

MAX20416 EV Kit PCB Layouts (continued)

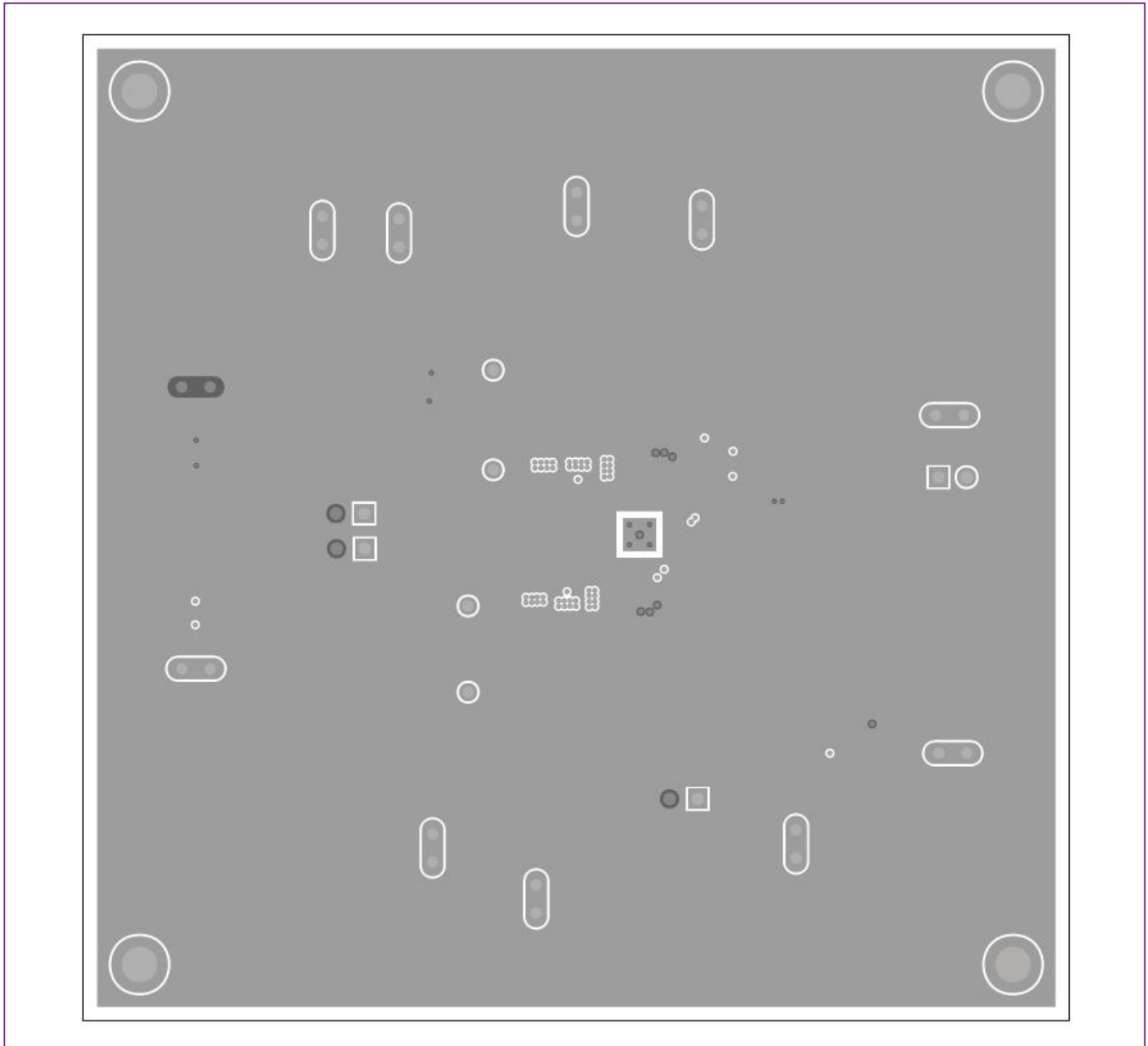

MAX20416 EV Kit PCB Layout—Internal Layer 3

MAX20416 EV Kit PCB Layouts (continued)

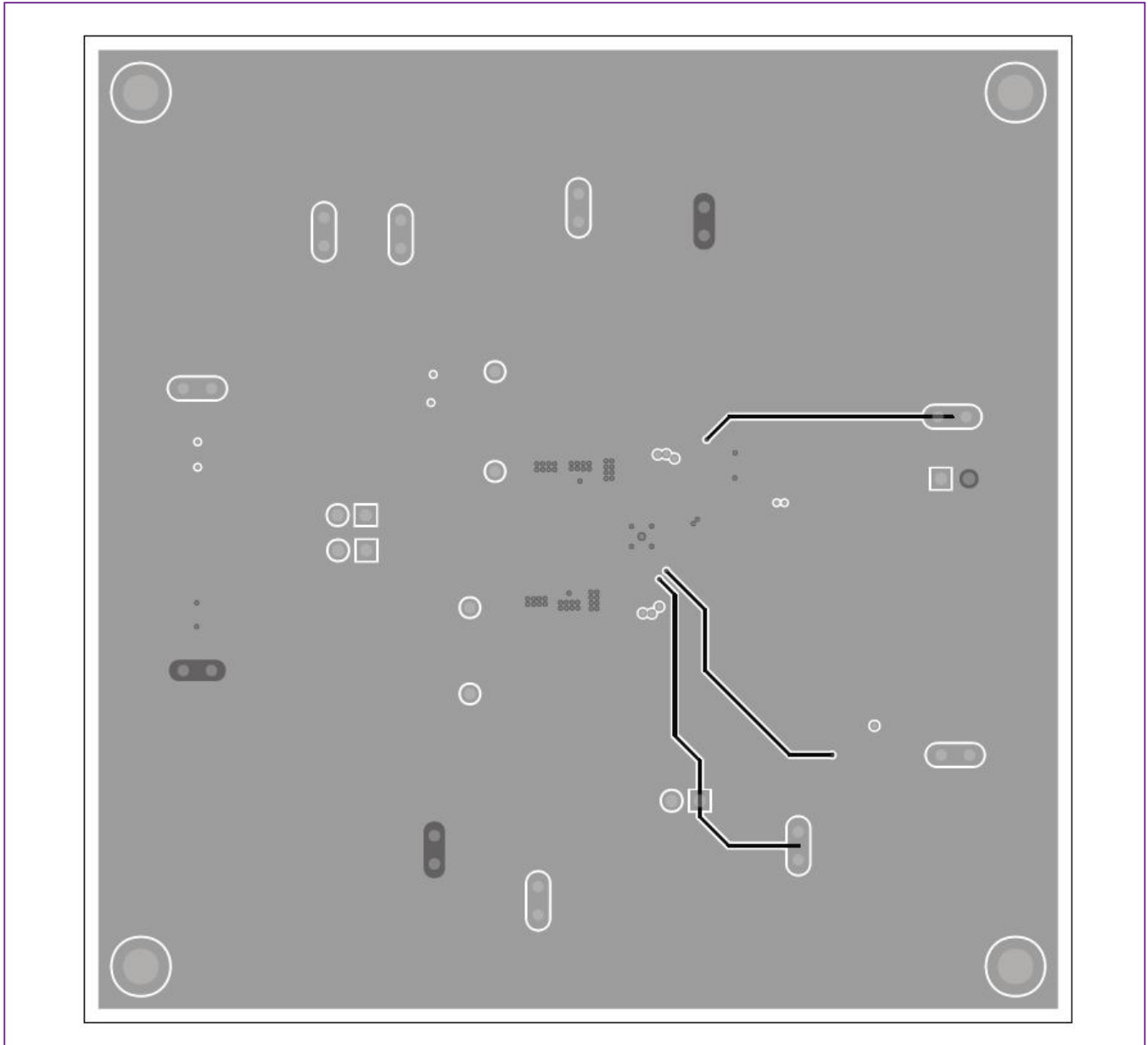

MAX20416 EV Kit PCB Layout—Bottom Layer

Revision History

REVISION NUMBER	REVISION DATE	DESCRIPTION	PAGES CHANGED
0	5/17	Initial release	—

For pricing, delivery, and ordering information, please visit Maxim Integrated's online storefront at <https://www.maximintegrated.com/en/storefront/storefront.html>.

Maxim Integrated cannot assume responsibility for use of any circuitry other than circuitry entirely embodied in a Maxim Integrated product. No circuit patent licenses are implied. Maxim Integrated reserves the right to change the circuitry and specifications without notice at any time.

X-ON Electronics

Largest Supplier of Electrical and Electronic Components

Click to view similar products for [Power Management IC Development Tools](#) category:

Click to view products by [Maxim](#) manufacturer:

Other Similar products are found below :

[EVB-EP5348UI](#) [MIC23451-AAAYFL EV](#) [MIC5281YMME EV](#) [124352-HMC860LP3E](#) [DA9063-EVAL](#) [ADP122-3.3-EVALZ](#) [ADP130-0.8-EVALZ](#) [ADP130-1.8-EVALZ](#) [ADP1740-1.5-EVALZ](#) [ADP1870-0.3-EVALZ](#) [ADP1874-0.3-EVALZ](#) [ADP199CB-EVALZ](#) [ADP2102-1.25-EVALZ](#) [ADP2102-1.875EVALZ](#) [ADP2102-1.8-EVALZ](#) [ADP2102-2-EVALZ](#) [ADP2102-3-EVALZ](#) [ADP2102-4-EVALZ](#) [AS3606-DB](#) [BQ25010EVM](#) [BQ3055EVM](#) [ISLUSBI2CKIT1Z](#) [LP38512TS-1.8EV](#) [EVAL-ADM1186-1MBZ](#) [EVAL-ADM1186-2MBZ](#) [ADP122UJZ-REDYKIT](#) [ADP166Z-REDYKIT](#) [ADP170-1.8-EVALZ](#) [ADP171-EVALZ](#) [ADP1853-EVALZ](#) [ADP1873-0.3-EVALZ](#) [ADP198CP-EVALZ](#) [ADP2102-1.0-EVALZ](#) [ADP2102-1-EVALZ](#) [ADP2107-1.8-EVALZ](#) [ADP5020CP-EVALZ](#) [CC-ACC-DBMX-51](#) [ATPL230A-EK](#) [MIC23250-S4YMT EV](#) [MIC26603YJL EV](#) [MIC33050-SYHL EV](#) [TPS60100EVM-131](#) [TPS65010EVM-230](#) [TPS71933-28EVM-213](#) [TPS72728YFFEVM-407](#) [TPS79318YEQEVM](#) [UCC28810EVM-002](#) [XILINXPWR-083](#) [LMR22007YMINI-EVM](#) [LP38501ATJ-EV](#)