

## MAX20471 Evaluation Kit

Evaluates: MAX20471

### General Description

The MAX20471 evaluation kit demonstrates the performance of the MAX20471, which is part of the MAX20471–MAX20473 series of high-efficiency, low-voltage DC-DC converters. The converter ICs boost a 3.0V to 4.0V input supply to between 3.8V and 5.25V at up to 500mA. The boost converters achieve  $\pm 1.5\%$  output error over load, line, and temperature range.

The IC features a 2.2MHz fixed-frequency forced-PWM (FPWM) mode for better noise immunity and load-transient response, and a pulse-frequency modulation mode (skip) for increased efficiency during light-load operation. The 2.2MHz frequency operation enables the use of all-ceramic capacitors and minimizes external components. The programmable spread-spectrum-frequency modulation minimizes radiated electromagnetic emissions. Integrated low  $R_{DS(ON)}$  switches improve efficiency at heavy loads and make the layout a much simpler task with respect to discrete solutions.

The regulator includes True Shutdown™, soft-start, over-current, and overtemperature protections.

### Benefits and Features

- 3.0V to 4.0V Operating Supply Voltage
- 3.8V to 5.25V Fixed Output
- 500mA Output Version Populated; Compatible with 1A and 2A Output Versions
- 2.2MHz Operation
- Feedback Injection Point-to-Test Stability
- Robust for the Automotive Environment
  - Current Mode, Forced-PWM and Skip Operation
  - Overtemperature and Short-Circuit Protection
  - $-40^{\circ}\text{C}$  to  $+125^{\circ}\text{C}$  Operating Range
- Proven PCB Layout
- Fully Assembled and Tested

### Quick Start

#### Required Equipment

- MAX20471 EV kit
- 3.3V, 2A power supply
- 10 $\Omega$ , 25W resistor or 1A electronic load
- Digital multimeter (DMM)

#### Procedure

The EV kit is fully assembled and tested. Follow the steps below to verify board operation:

- 1) Connect the 3.3V supply to the VSUP and GND PCB pads.
- 2) Remove the EN jumper.
- 3) Activate the supply. Use the DMM to verify that the voltage at the supply is 3.3V, the output is 0V, and the  $\overline{\text{RESET}}$  pin voltage is 0V.
- 4) Place a jumper across pins 1-2 on the EN header. Use the DMM to verify that the voltage at the output is 5.0V and the  $\overline{\text{RESET}}$  pin is 3.3V.
- 5) Connect the load (either resistive or electronic) to OUT and GND.
- 6) Use the DMM to verify output voltage is still 5.0V.

[Ordering Information](#) appears at end of data sheet.

*True Shutdown is a trademark of Maxim Integrated Products, Inc.*

## Detailed Description of Hardware

The MAX20471 EV kit comes fully assembled and tested. The IC populated on the EV kit determines the package and the output current limit. Any of the ICs in the MAX204xx series of high-efficiency, low-voltage DC-DC converters can be tested on this EV kit. Changing the IC may also require changing the external components on the EV kit. Refer to the MAX20471–MAX20473 IC data sheet for guidance on selecting the proper components.

### EV Kit Interface

The VSUP and GND PCB pads provide power to the EV kit. Input capacitance is included to reduce peak currents drawn from the power source and reduces noise and voltage ripple on the input caused by the circuit's switching. The regulator provides output power at the OUT and GND pins. Output capacitance is selected to ensure proper stability.

The enable control input (EN) activates the IC channel from its low-power shutdown state. EN has an input threshold of 1.0V (typ), with hysteresis of 80mV (typ). When an enable input goes high, the associated output voltage ramps up with the programmed soft-start time. The IC can be turned on either by installing a shunt/jumper across pins 1-2 on the EN header, or by applying a logic-high signal to the EN PCB pad. To turn off the IC, remove the shunt on pins 1-2 and install a shunt across pins 2-3 on the EN header, or apply a logic-low signal to the EN PCB pad.

### Synchronization and Switching

The IC has an on-chip oscillator that provides a 2.2MHz (typ) switching frequency. Depending on the condition of SYNC, two operation modes exist. If SYNC is unconnected or at GND, the IC operates in a highly efficient pulse-skipping mode if the load current is below the skip-mode current threshold. If the current is above the threshold, the IC automatically changes to FPWM mode. If SYNC is at VSUP or has a frequency applied to it, the IC always operates in FPWM mode. The IC can be switched during operation between FPWM and skip mode by switching SYNC. SYNC can be connected to VSUP by installing a shunt across pins 1-2 on the SYNC header, or connected to GND by installing a shunt across pins 2-3 on the SYNC header. An external square wave can be applied to the SYNC test point to cause the converter to switch at the applied frequency (refer to the MAX20471–MAX20473 IC data sheet for limits).

### Spread Spectrum (SSEN)

The IC has the option to enable spread-spectrum switching to reduce EMI. Spread spectrum can be enabled by installing a jumper between pins 1-2 on the SSEN header, or disabled by installing a jumper between pins 2-3. With spread spectrum enabled, the internal oscillator varies the internal operating frequency by  $\pm 3\%$  relative to the internally generated 2.2MHz (typ) operating frequency. This function does not apply to an externally applied oscillation frequency. The spread-spectrum frequency generated is pseudorandom, with a repeat rate well below the audio band.

### Fault Flag Signal ( $\overline{\text{RESET}}$ )

The IC features an open-drain reset output for each output that asserts low when the corresponding output voltage is outside the undervoltage/overvoltage window.  $\overline{\text{RESET}}$  remains asserted for a fixed timeout period after the output rises to its regulated voltage. The fixed timeout period is 0.5ms by default, but can also be factory-set to 3.7ms, 7.4ms, or 14.9ms. To obtain a logic signal, place a pullup resistor between the  $\overline{\text{RESET}}$  pin and VSUP.

### PCB Layout Guidelines

Proper PCB layout of the system is crucial to good performance. The loop area created by the DC-DC components must be minimized as much as possible. Place the input capacitor, power inductor, and output capacitor as close as possible to the IC package. The output capacitor experiences the greatest amount of ripple current, so should be placed closest to the IC. Increasing the loop area will increase EMI and switching jitter, but may also degrade regulation and transient response. Optimal positioning and routing has been implemented on this EV kit.

## Ordering Information

PART	TYPE
MAX20471EVKIT#	EV Kit

#Denotes RoHS compliant.

## MAX20471 EV Kit Bill of Materials

REF DESIGNATOR	QTY	DESCRIPTION	MFG PART #
C1	1	4.7 $\mu$ F ceramic cap, 0805 size, 10V, X7R	TDK CGA4J3X7R1A475K125AB
C2	1	22 $\mu$ F ceramic cap, 1210 size, 10V, X7R	Murata GCM32ER71A226KE12
C3	1	1 $\mu$ F ceramic cap, 0402 size, 10V, X7S	Murata GCM155C71A105KE38D
C4	1	220 $\mu$ F electrolytic capacitor, 6.3mm dia, 6.3V	Panasonic EEE-FP0J221AP
C5, C6	2	0.1 $\mu$ F ceramic cap, 0402 size, 16V, X7R	TDK CGA2B1X7R1C104K050BC
EN, INJ, OUT, /RESET, SSEN, SYNC	6	Test point, 0.63"	
EN, SSEN, SYNC	3	Pin header, 3 position, 0.100" pitch (comes in 40-pin strips, cut to fit)	
GND (x4),OUT, VSUP	6	Test loop, wire, 18AWG solid	
L1	1	1.0 $\mu$ H inductor TDK TFM-series	TDK TFM252012ALMA1R0
R1	1	47kohm, 5%, 0603 size	Any
R2, R3, R4	3	10kohm, 5%, 0603 size	Any
R5	1	10ohm, 1%, 0201 size	Panasonic ERJ-1GEF10R0C
U1	1	MAX20471	Maxim MAX20471ATCAV+
—	1	PCB: MAX20471/72/73 EV KIT	Maxim MAX20471EVKIT#
—	3	Shunt, 2-position, 0.100" pitch	

MAX20471 EV Kit Schematic

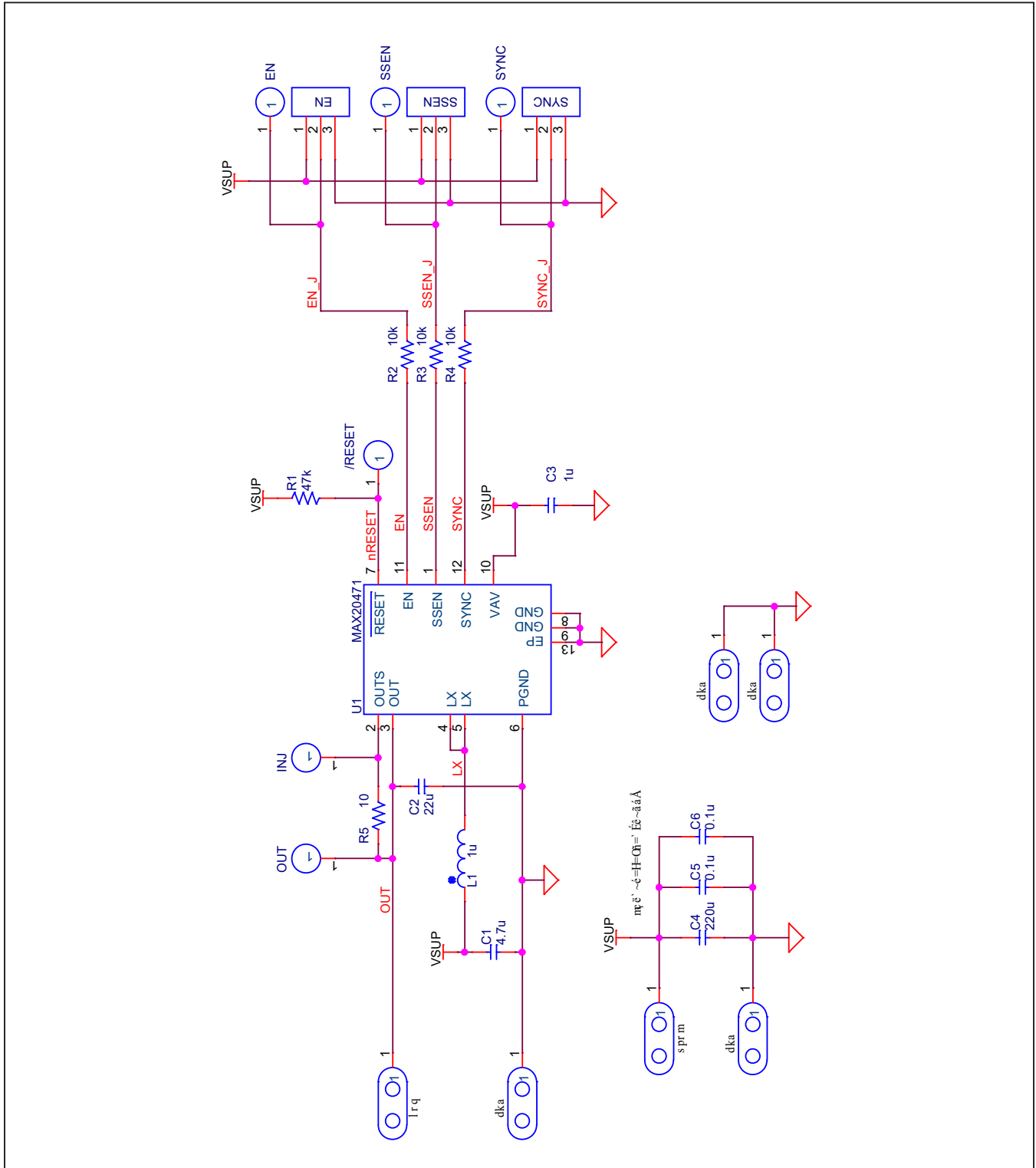

MAX20471 EV Kit PCB Layouts

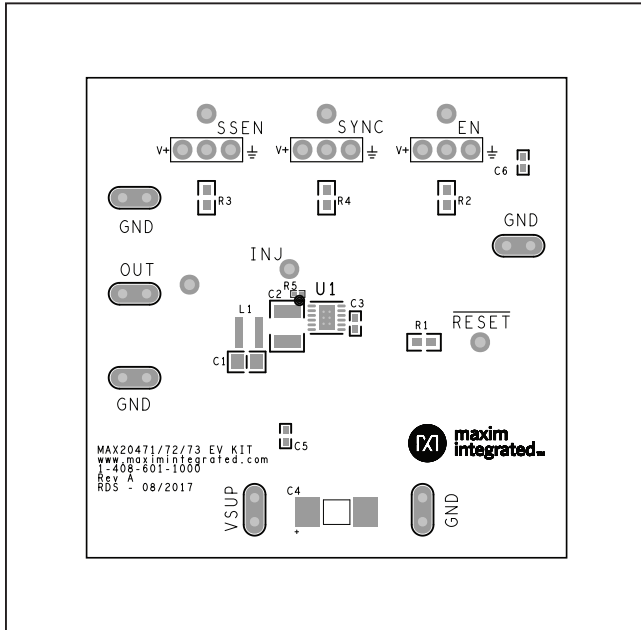

MAX20471 EV Kit Component Placement Guide—Top Silkscreen

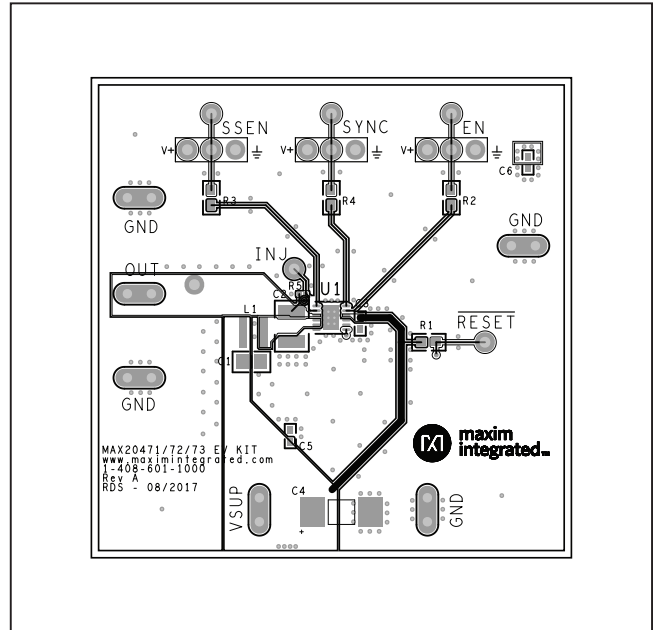

MAX20471 EV Kit Component Placement Guide—Top Assembly

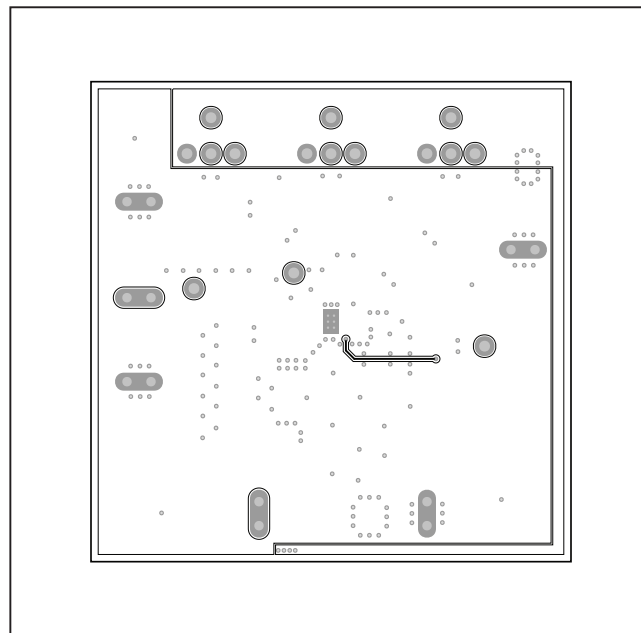

MAX20471 EV Kit PCB Layout—Bottom

## Revision History

REVISION NUMBER	REVISION DATE	DESCRIPTION	PAGES CHANGED
0	11/17	Initial release	—

For pricing, delivery, and ordering information, please visit Maxim Integrated's online storefront at <https://www.maximintegrated.com/en/storefront/storefront.html>.

*Maxim Integrated cannot assume responsibility for use of any circuitry other than circuitry entirely embodied in a Maxim Integrated product. No circuit patent licenses are implied. Maxim Integrated reserves the right to change the circuitry and specifications without notice at any time.*

## X-ON Electronics

Largest Supplier of Electrical and Electronic Components

*Click to view similar products for [Power Management IC Development Tools](#) category:*

*Click to view products by [Maxim](#) manufacturer:*

Other Similar products are found below :

[EVB-EP5348UI](#) [MIC23451-AAAYFL EV](#) [MIC5281YMME EV](#) [124352-HMC860LP3E](#) [DA9063-EVAL](#) [ADP122-3.3-EVALZ](#) [ADP130-0.8-EVALZ](#) [ADP130-1.8-EVALZ](#) [ADP1740-1.5-EVALZ](#) [ADP1870-0.3-EVALZ](#) [ADP1874-0.3-EVALZ](#) [ADP199CB-EVALZ](#) [ADP2102-1.25-EVALZ](#) [ADP2102-1.875EVALZ](#) [ADP2102-1.8-EVALZ](#) [ADP2102-2-EVALZ](#) [ADP2102-3-EVALZ](#) [ADP2102-4-EVALZ](#) [AS3606-DB](#) [BQ25010EVM](#) [BQ3055EVM](#) [ISLUSBI2CKIT1Z](#) [LP38512TS-1.8EV](#) [EVAL-ADM1186-1MBZ](#) [EVAL-ADM1186-2MBZ](#) [ADP122UJZ-REDYKIT](#) [ADP166Z-REDYKIT](#) [ADP170-1.8-EVALZ](#) [ADP171-EVALZ](#) [ADP1853-EVALZ](#) [ADP1873-0.3-EVALZ](#) [ADP198CP-EVALZ](#) [ADP2102-1.0-EVALZ](#) [ADP2102-1-EVALZ](#) [ADP2107-1.8-EVALZ](#) [ADP5020CP-EVALZ](#) [CC-ACC-DBMX-51](#) [ATPL230A-EK](#) [MIC23250-S4YMT EV](#) [MIC26603YJL EV](#) [MIC33050-SYHL EV](#) [TPS60100EVM-131](#) [TPS65010EVM-230](#) [TPS71933-28EVM-213](#) [TPS72728YFFEVM-407](#) [TPS79318YEQEVM](#) [UCC28810EVM-002](#) [XILINXPWR-083](#) [LMR22007YMINI-EVM](#) [LP38501ATJ-EV](#)