

# MAX22088 Evaluation Kit

Evaluates: MAX22088

## General Description

The MAX22088 evaluation kit (EV kit) provides a proven design to evaluate the MAX22088 Home Bus transceiver.

The EV kit includes an evaluation board with two circuits, a master circuit, and a remote/device circuit, that can be used to demonstrate the full functionality of the MAX22088 Home Bus transceiver in a complete Home Bus application.

For easy evaluation, on the remote/device side, the MAX15462 5V step-down DC-DC converter is included to power external system loads at 200mA (max). In addition, the MAX12931 digital isolator is used for convenient and correct measuring of digital Home Bus signals.

## Features

- Easy Evaluation of the MAX22088
- Two On-Board Configurations, Master Circuit and Remote/Device Circuit, for Complete Home Bus Evaluation
- Robust Design with  $\pm 1\text{kV}$  Line-to-Line and Line-to-GND Surge Transient Immunity
- On-Board Isolated Digital Interface for Simple Testing and Monitoring
- Fully Assembled and Tested
- Proven PCB Layout

## MAX22088 EV Kit Board

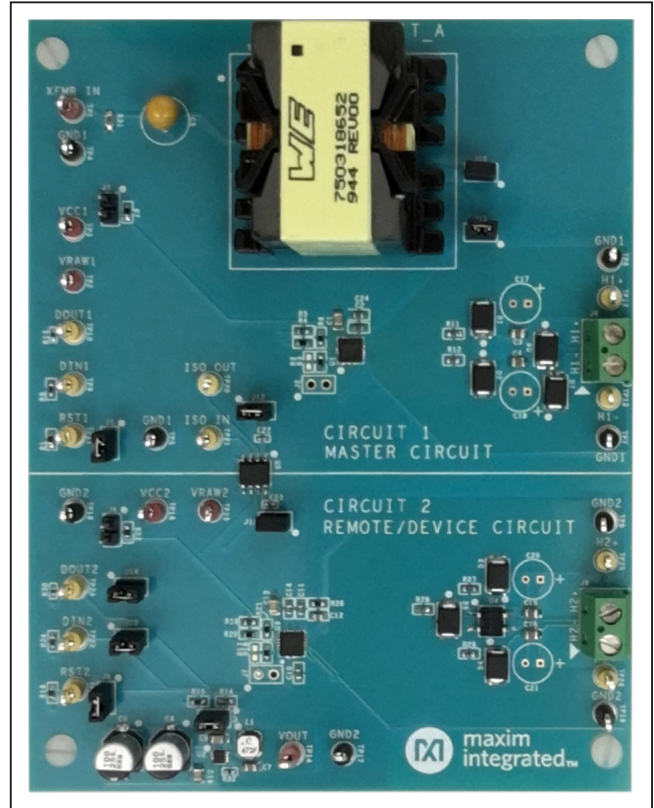

**Ordering Information** appears at end of data sheet.

## MAX22088 EV Kit Block Diagram

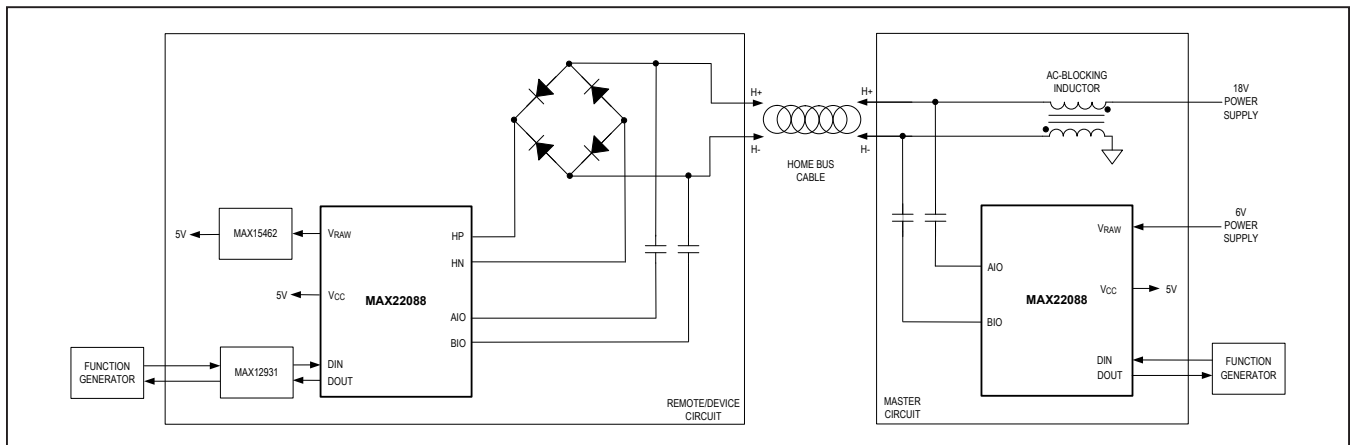

**Quick Start**

**Recommended Equipment**

- MAX22088EVKIT#
- Two 24V, 200mA DC power supplies
- Digital multimeter
- Data generator, or function generator
- Digital oscilloscope
- A pair of twisted wires (22 or 24 AWG) 20cm or longer

**Procedure**

The MAX22088 EV kit is fully assembled and tested. Follow the steps below to verify board operation:

**Note:** Do not short the ground of master circuit (GND1) and remote/device circuit (GND2) of the board. See the [Master and Remote/Device Grounds](#) section for more information. Ensure that the ground terminal of the power supply is not connected to earth ground.

- 1) Connect the H1+ of J4 (pin 1) to the H2+ of J9 (pin 1) with one of the twisted wires.
- 2) Connect the H1- of J4 (pin 2) to the H2- of J9 (pin 2) with the other of the twisted wires.
- 3) Verify that all jumpers are in their default positions as shown in [Table 1](#).

**Table 1. MAX22088 EV Kit Shunt Positions**

JUMPER	SHUNT POSITION	DEVICE	DESCRIPTION
<b>CIRCUIT 1 (MASTER CIRCUIT)</b>			
J1	Open	U1	Disable the MAX22088 (U1) transmitter output.
	1-2*		Enable the MAX22088 (U1) transmitter output.
J2	N/A		Jumper is not installed. Do not use.
J3	Open*		Enable the MAX22088 (U1) internal high-pass filter.
	1-2		Disable the MAX22088 (U1) internal high-pass filter.
J10	Open		-
	1-2*	Connect the transformer to the H+ line.	
J11	Open	Disconnect the transformer from the H- line.	
	1-2*	Connect the transformer to the H- line.	
<b>CIRCUIT 2 (REMOTE/DEVICE CIRCUIT)</b>			
J5	Open	U2	Disable the MAX15462 (U2) DC-DC converter.
	1-2*		Enable the MAX15462 (U2) DC-DC converter.
J6	Open	U3	Disable the MAX22088 (U3) transmitter output.
	1-2*		Enable the MAX22088 (U3) transmitter output.
J7	N/A		Jumper is not installed. Do not use.
J8	Open*		Enable the MAX22088 (U3) internal high-pass filter.
	1-2		Disable the MAX22088 (U3) internal high-pass filter.
<b>DIGITAL ISOLATOR</b>			
J12	Open	U5	Disconnect the MAX12931 (U5) power supply from VCC_1 (master circuit).
	1-2*		Connect the MAX12931 (U5) power supply to VCC_1 (master circuit).
J13	Open	U5	Disconnect the MAX12931 (U5) power supply from VCC_2 (remote/device circuit).
	1-2*		Connect the MAX12931 (U5) power supply to VCC_2 (remote/device circuit).
J14	Open	U5	Disable the MAX12931 (U5) ISO_OUT output
	1-2*		Enable the MAX12931 (U5) ISO_OUT output. DOUT2 is connected to ISO_OUT.
J15	Open	U5	Disable the MAX12931 (U5) ISO_IN input.
	1-2*		Enable the MAX12931 (U5) ISO_IN input. ISO_IN is connected to DIN2.

\*Default position

- 4) Set the first 24V DC power supply to 18V and connect it to the XFMR\_IN test point (TP1). Connect the ground terminal to the GND1 test point (TP4).
- 5) Set the second 24V DC power supply to 6V and connect it to the VRAW1 test point (TP2). Connect the ground terminal to the GND1 test point (TP4).
- 6) Connect the digital multimeter to the VCC1 test point (TP3). Connect the ground terminal to the GND1 test point (TP4).
- 7) Turn both DC power supplies on.
- 8) Verify that the digital multimeter reads 5V (typ) on VCC1 (TP3).
- 9) Move the digital multimeter to the VCC2 test point (TP16) and GND2 test point (TP18).
- 10) Verify that the VCC2 voltage is 5V (typ).
- 11) Move the digital multimeter to the VOUT test point (TP14).
- 12) Verify that the voltage on VOUT is 5V (typ).
- 13) Connect the oscilloscope probes to the ISO\_IN test point (TP21), the H1+ test point (TP12), the H1- test point (TP13), and the DOUT1 test point (TP10).
- 14) Connect the ground terminals for all scope probes to the GND1 test points (TP4, TP5, TP7, or TP12).
- 15) Connect the function generator to the ISO\_IN test point (TP21). Connect the ground terminal to the GND1 test point (TP5).
- 16) Set the function generator output to a 25kHz 0V–5V square wave with 50% duty cycle.
- 17) Turn on the function generator.
- 18) Verify that all signals are as shown in [Figure 1](#).

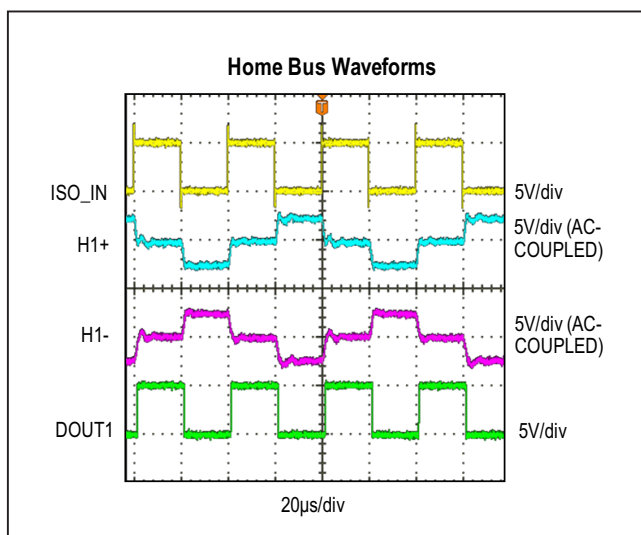

Figure 1. MAX22088 EV Kit Waveforms at 50kbps

## Detailed Description of Hardware

The MAX22088 EV kit consists of two MAX22088 circuit configurations for both master and remote/device transceiver evaluation. Connect both circuits together to build a complete Home Bus network.

In the master circuit, the MAX22088 is configured as a Home Bus master. Power is sourced from this circuit to the remote/device circuit when the on-board AC-blocking inductor (T1) is connected to the H+ and H- lines.

In the remote/device circuit, the MAX22088 is configured as a Home Bus remote/device. Power is received from the master circuit through the H+ and H- lines.

The MAX22088 EV kit also includes an on-board 5V step-down DC-DC converter to power external loads up to 200mA(max) on the remote/device side. An on-board digital isolator (MAX12931) is included for easy monitoring and evaluation of digital signals.

## Home Bus System

The MAX22088 Home Bus transceiver complies with the Home Bus standard where data and power are passed on a single pair of wires. The MAX22088 EV kit is optimized for 57.6kbps operation. External component modifications are required to operate the EV kit at a lower data rate. Contact Maxim before operating the EV kit at data rates below 20kbps.

## Master Circuit

Power is sourced from the master circuit in a Home Bus network. The power for downstream Home Bus devices is supplied to the H+ line through the on-board AC-blocking inductor. Connect an external voltage to the XFMR\_IN test point (TP1) to supply power to the Home Bus lines. The MAX22088 EV kit master circuit also requires an external voltage at VRAW. Connect a minimum 5V supply to the VRAW1 test point (TP2). When the MAX22088 is configured as a master transceiver, it receives digital signals from the remote/device circuit through the H+ and H- lines at the J4 terminal block. Monitor the DOUT1 test point (TP10) to verify the received digital signals.

## Remote/Device Circuit

The remote/device circuit in a Home Bus application receives power from the H+ and H- lines. On the MAX22088 EV kit, the remote transceiver (U3) is powered from the H+ and H- lines connected to the master circuit. A 5V regulated output is generated at the VCC2 test point (TP16). Signals connected to the digital input (DIN2) are transmitted over the H+ and H- lines to the master circuit when J4 is connected to J9.

## On-Board 5V DC-DC Regulator

The MAX22088 EV kit remote/device circuit includes a MAX15462 DC-DC step-down converter to generate a regulated 5V output at VOUT (TP14) that can be used to power external loads up to 200mA (max). Place a shunt on J5 to enable the 5V output at VOUT (TP14).

## RST Input

The MAX22088 uses the RST pin to enable or disable the transmitter and set the initial state of the transmitter output. Set RST high to disable the transmitter on the MAX22088. Set RST low to enable the transmitter. The receiver on the MAX22088 is always enabled.

Leave J1 open to set the MAX22088 in the master circuit (U1) to receive mode only. Place a shunt on J1 to enable the transmitter.

Leave J6 open to set the MAX22088 in the remote/device circuit (U3) to receive mode only. Place a shunt on J6 to enable the transmitter.

When the master and remote/device circuits are connected, set one MAX22088 device to receive mode and enable the transmitter of the other MAX22088.

## High-Pass Filter

The MAX22088 features an integrated high-pass filter to filter out lower frequency voltage fluctuations received on the H+ and H- lines.

Place a shunt on J3 to enable the high-pass filter on the MAX22088 in the master circuit (U1). Leave J3 open to disable the internal filter.

Place a shunt on J8 to enable the high-pass filter on the MAX22088 in the remote/device circuit (U3). Leave J8 open to disable the internal filter.

## Transceiver Termination

The MAX22088 EV kit includes an on-board 82Ω dynamic termination resistor between BIO and TERM, and a 1kΩ static termination resistor between AIO and BIO, at both master and remote circuits.

## Master and Remote/Device Grounds

In a typical Home Bus application, the remote device ground is isolated from the master ground. Shorting the master and remote device grounds creates a ground loop and can cause signal integrity issues during normal operation.

On the MAX22088 EV kit, ensure that GND1 and GND2 test points are never connected. Do not probe test points

on both circuits at the same time to avoid shorting the grounds through the oscilloscope probes. Use the on-board isolation interface to verify signals on both circuits simultaneously, if needed. See the [Isolated Input and Output](#) section for more information.

## Isolated Input and Output

The MAX22088 EV kit features an on-board digital isolator, MAX12931, for easy monitoring and evaluation of digital signals. The MAX12931 (U5) ensures the master ground (GND1) and remote/device ground (GND2) are not inadvertently connected during evaluation.

Place shunts on the J12–J15 jumpers to enable the on-board digital isolator.

Connect the digital input signal to the ISO\_IN test point (TP21). This signal is passed through the MAX12931 to the DIN input (DIN2) of the remote/device MAX22088 (U3). The signal at the ISO\_OUT test point (TP20) is the digital output (DOUT2) of the MAX22088 (U3) in remote/device circuit. When the master and remote/device circuits are connected, monitor the digital output (DOUT1) of the master MAX22088 (U1) to verify that the output signal of the Home Bus system is the same as the digital input signals (ISO\_IN).

Ensure that all scope grounds are connected to GND1 during operation.

## IEC 61000-4-4 Surge Immunity Compliance

The MAX22088 EV kit is designed and tested to withstand ±1kV surge transients, both line-to-ground and line-to-line, in compliance with IEC standard 61000-4-4. The MAX22088 Home Bus pins HP, HN, AIO, BIO, and TERM are protected from surge transients with external components. TVS diodes D5 and D6 protect HP and HN pins from surge transients between H+ and H- lines. TVS diode D7 provides protection from surge transients between H+/H- line and ground. TVS diodes D1, D2, D3, and D4, and current-limiting resistors R11, R12, R27, and R28 further protect AIO, BIO, and TERM pins. See the MAX22088 EV kit schematic and *Surge Protection* section in *Application Information* in the MAX22088 data sheet for more information.

## Ordering Information

PART	TYPE
MAX22088EVKIT#	EV Kit

#Denotes RoHS compliant.

MAX22088 EV Kit Bill of Materials

ITEM	REF_DES	DN/DNP	QTY	MFG PART #	MANUFACTURER	VALUE	DESCRIPTION	COMMENTS
1	C1, C6, C13, C19	-	4	CC0805JKX7R9BB105	YAGEO	1UF	CAP; SMT (0805); 1UF; 5%; 50V; X7R; CERAMIC CHIP	
2	C2, C14	-	2	C0603C105K4RAC; GRM188R71C105KA12; C1608X7R1C105K080AC; EMK107B7105KA; GCM188R71C105KA64; CGA3E1X7R1C105K080AC; 0603YC105KA2A	KEMET,MURATA;TDK; TAIYO YUDEN,MURATA;TDK;AVX	1UF	CAPACITOR; SMT (0603); CERAMIC CHIP; 1UF; 16V; TOL=10%; MODEL=; TG=-55 DEGC TO +125 DEGC; TC=X7R	
3	C3, C4, C15, C16	-	4	C2012X7R1H225K125AC; CGA4J3X7R1H225K125AB; CGA4J3X7R1H225K125AE	TDK;TDK;TDK	2.2UF	CAPACITOR; SMT (0805); CERAMIC CHIP; 2.2UF; 50V; TOL=10%; TG=-55 DEGC TO +125 DEGC; TC=X7R	
4	C5	-	1	TAP106K050SCS	AVX	10UF	CAPACITOR; THROUGH HOLE-RADIAL LEAD; TANTALUM; 10UF; 50V; TOL=10%; MODEL=TAP SERIES	
5	C7	-	1	GRM21BR61A106KE19; ECJ-2FB1A106;CL21A106KPLQNC; GRM219R61A106KE44	MURATA;PANASONIC; SAMSUNG ELECTRONICS;MURATA	10UF	CAPACITOR; SMT (0805); CERAMIC CHIP; 10UF; 10V; TOL=10%; MODEL=; TG=-55 DEGC TO +85 DEGC; TC=X5R	
6	C8, C9	-	2	EEE-1EA101XP	PANASONIC	100UF	CAP; SMT (CASE_D8); 100UF; 20%; 25V; ALUMINUM-ELECTROLYTIC	
7	C10, C11	-	2	GCJ188R71H104KA12; GCM188R71H104K; CGA3E2X7R1H104K080AA	MURATA;MURATA;TDK	0.1UF	CAPACITOR; SMT (0603); CERAMIC CHIP; 0.1UF; 50V; TOL=10%; TG=-55 DEGC TO +125 DEGC; TC=X7R; AUTO	
8	C12	-	1	UMK107BJ105KA; C1608X5R1H105K080AB; CL10A105KB8NNN; GRM188R61H105KAAL	TAIYO YUDEN;TDK; SAMSUNG;MURATA	1UF	CAPACITOR; SMT (0603); CERAMIC CHIP; 1UF; 50V; TOL=10%; MODEL=; MK SERIES; TG=-55 DEGC TO +85 DEGC	
9	C22, C23	-	2	C0402C104J4RAC; GCM155R71C104JA55	KEMET;MURATA	0.1UF	CAPACITOR; SMT (0402); CERAMIC CHIP; 0.1UF; 16V; TOL=5%; MODEL=; TG=-55 DEGC TO +125 DEGC; TC=X7R	
10	C24, C25	-	2	C1608X5R1A106K080AC	TDK	10UF	CAPACITOR; SMT (0603); CERAMIC CHIP; 10UF; 10V; TOL=10%; MODEL=; TG=-55 DEGC TO +85 DEGC; TC=X5R	
11	D1-D4	-	4	P6SMB6.8A	LITTELFUSE	5.8V	DIODE; TVS; SMB (DO-214AA); VRM=5.8V; IPP=58.1A	
12	D5, D6	-	2	SMBJ24A	LITTELFUSE	24V	DIODE; TVS; SMB (DO-214AA); PIV=24V; IPP=15.5A	
13	D7	-	1	P6SMB6.8CA	LITTELFUSE	5.8V	DIODE; TVS; SMB (DO-214AA); VRM=5.8V; IPP=58.1A	
14	J1, J3, J5, J6, J8, J10-J15	-	11	TSW-102-23-G-S	SAMTEC	TSW-102-23-G-S	CONNECTOR; THROUGH HOLE; SINGLE ROW; STRAIGHT; 2PINS; -55 DEGC TO +125 DEGC	
15	J4, J9	-	2	282837-2	TE CONNECTIVITY	282837-2	CONNECTOR; FEMALE; THROUGH HOLE; PC TERMINAL BLOCK; RIGHT ANGLE; 2PINS;	
16	L1	-	1	LPS4018-473MLB	COILCRAFT	47UH	INDUCTOR; MAGNETICALLY SHIELDED FERRITE BOBBIN CORE; SMT; 47UH; TOL=+-20%; 0.68A; -40 DEGC TO +85 DEGC	
17	MH1-MH4	-	4	9032	KEYSTONE	9032	MACHINE FABRICATED; ROUND-THRU HOLE SPACER; NO THREAD; M3.5; 5/8IN; NYLON	
18	R1, R7, R15, R16, R22	-	5	CRCW0603100KFK;RC0603FR-07100KL; RC0603FR-13100KL;ERJ-3EKF1003; AC0603FR-07100KL	VISHAY DALE;YAGEO; YAGEO;PANASONIC	100K	RESISTOR; 0603; 100K; 1%; 100PPM; 0.10W; THICK FILM	
19	R3, R18	-	2	CRCW060362K0FK	VISHAY DALE	62K	RES; SMT (0603); 62K; 1%; +/-100PPM/DEGK; 0.1W	
20	R4, R20	-	2	MCR03EZPFX2002;ERJ-3EKF2002; CR0603-FX-2002ELF;CRCW060320K0FK	ROHM;PANASONIC;BOURNS; VISHAY DALE	20K	RESISTOR; 0603; 20K OHM; 1%; 100PPM; 0.10W; THICK FILM	
21	R5, R19	-	2	CRCW060327K0FK	VISHAY DALE	27K	RESISTOR; 0603; 27K OHM; 1%; 100PPM; 0.10W; THICK FILM	
22	R6, R21	-	2	CRCW06034K30FK	VISHAY DALE	4.3K	RESISTOR; 0603; 4.3K OHM; 1%; 100PPM; 0.1W; THICK FILM	
23	R8, R23	-	2	CRCW12061001FK; CRCW12061K00FK	VISHAY INTERTECHNOLOGIES; VISHAY INTERTECHNOLOGIES	1K	RESISTOR; 1206; 1K; 1%; 100PPM; 1/4W; THICK FILM	
24	R9, R24	-	2	CRCW060310K0FK;ERJ-3EKF1002	VISHAY DALE;PANASONIC	10K	RESISTOR; 0603; 10K; 1%; 100PPM; 0.10W; THICK FILM	
25	R10, R25	-	2	RL1220S-820-F	SUSUMU CO LTD.	82	RESISTOR; 0805; 82 OHM; 1%; 200PPM; 0.33W; THICK FILM	



MAX22088 EV Kit Bill of Materials (continued)

ITEM	REF_DES	DN/DNP	QTY	MFG PART #	MANUFACTURER	VALUE	DESCRIPTION	COMMENTS
26	R11, R12, R27, R28	-	4	ERJ-3RQF4R7	PANASONIC	4.7	RESISTOR, 0603, 4.7 OHM, 1%, 100PPM, 0.10W, THICK FILM	
27	R13, R30	-	2	CRCW04022K70FK	VISHAY DALE	2.7K	RESISTOR, 0402, 2.7K OHM, 1%, 100PPM, 0.0625W, THICK FILM	
28	R14	-	1	RCW06033K30FK; RC0603FR-073K3L,RK73H1J3301F	VISHAY;YAGEO;VISHAY	3.3K	RESISTOR, 0603, 3.3K OHM, 1%, 100PPM, 0.10W, THICK FILM	
29	R26	-	1	CRCW0603180KFK	VISHAY DALE	180K	RESISTOR, 0603, 180K OHM, 1%, 100PPM, 0.10W, THICK FILM	
30	R29	-	1	ERJ-3RQF1R0;CRCW06031R00FK	PANASONIC;VISHAY	1	RESISTOR, 0603, 1 OHM, 1%, 100PPM, 0.10W, THICK FILM	
31	R31	-	1	TNPW0805100KBE;ERA-6YEB104V	VISHAY DALE;PANASONIC	100K	RESISTOR, 0805, 100K; 0.1%; 25PPM; 0.125W; THIN FILM	
32	R32	-	1	RC0402JR-070RL; CR0402-16W-000RJT	YAGEO PHYCOMP;VENKEL LTD.	0	RESISTOR, 0402; 0 OHM; 5%; JUMPER; 0.063W; THICK FILM	
33	T1	-	1	750318652	WURTH ELECTRONICS INC	750318652	EVKIT PART - TRANSFORMER; 750318652; TURN RATIO=1:1; 12 PINS; TH	
34	TP1-TP3, TP14-TP16	-	6	5010	KEYSTONE	N/A	TEST POINT; PIN DIA=0.125IN; TOTAL LENGTH=0.445IN; BOARD HOLE=0.063IN; RED; PHOSPHOR BRONZE WIRE SIL;	
35	TP4-TP8, TP17-TP19	-	8	5011	KEYSTONE	N/A	TEST POINT; PIN DIA=0.125IN; TOTAL LENGTH=0.445IN; BOARD HOLE=0.063IN; BLACK; PHOSPHOR BRONZE WIRE SILVER PLATE FINISH;	
36	TP9-TP13, TP20-TP26	-	12	5014	KEYSTONE	N/A	TEST POINT; PIN DIA=0.125IN; TOTAL LENGTH=0.445IN; BOARD HOLE=0.063IN; YELLOW; PHOSPHOR BRONZE WIRE SILVER PLATE FINISH;	
37	U1, U3	-	2	MAX22088GTG+	MAXIM	MAX22088GTG+	EVKIT PART - IC; MAX22088GTG+; HOMEBUS TRANSCEIVER; PACKAGE CODE: T2444+4C; PACKAGE OUTLINE NUMBER: 21-0139; LAND PATTERN NUMBER: 90-0022	
38	U2	-	1	MAX15462BATA+	MAXIM	MAX15462BATA+	IC: VCON; 42V; 300MILLIAMPERE; ULTRA-SMALL; HIGH EFFICIENCY; SYNCHRONOUS STEP-DOWN DC-DC CONVERTER; TDFN8-EP	
39	U4	-	1	MB1S	ON SEMICONDUCTOR	MB1S	DIODE; RECT; SMT (SOIC-4); PIV=100V; IF=0.5A	
40	U5	-	1	MAX12931BASA+	MAXIM	MAX12931BASA+	IC; DISO; TWO-CHANNEL; LOW-POWER; 3KV RMS AND 5KV RMS DIGITAL ISOLATORS; NSOIC8	
41	PCB	-	1	MAX22088	MAXIM	PCB	PCB:MAX22088	-
42	C17, C18, C20, C21	DNP	0	USP1E220MDD	NICHICON	22UF	CAP; THROUGH HOLE-RADIAL LEAD; 22UF; 20%; 25V; ALUMINUM-ELECTROLYTIC	
43	J2, J7	DNP	0	TSW-102-23-G-S	SAMTEC	TSW-102-23-G-S	CONNECTOR; THROUGH HOLE; SINGLE ROW; STRAIGHT; 2PINS; -55 DEGC TO +125 DEGC	
44	R2, R17	DNP	0	CRCW0603120KFK	VISHAY DALE	120K	RESISTOR, 0603, 120K OHM, 1%, 100PPM, 0.10W, THICK FILM	
TOTAL			109					

MAX22088 EV Kit Schematics

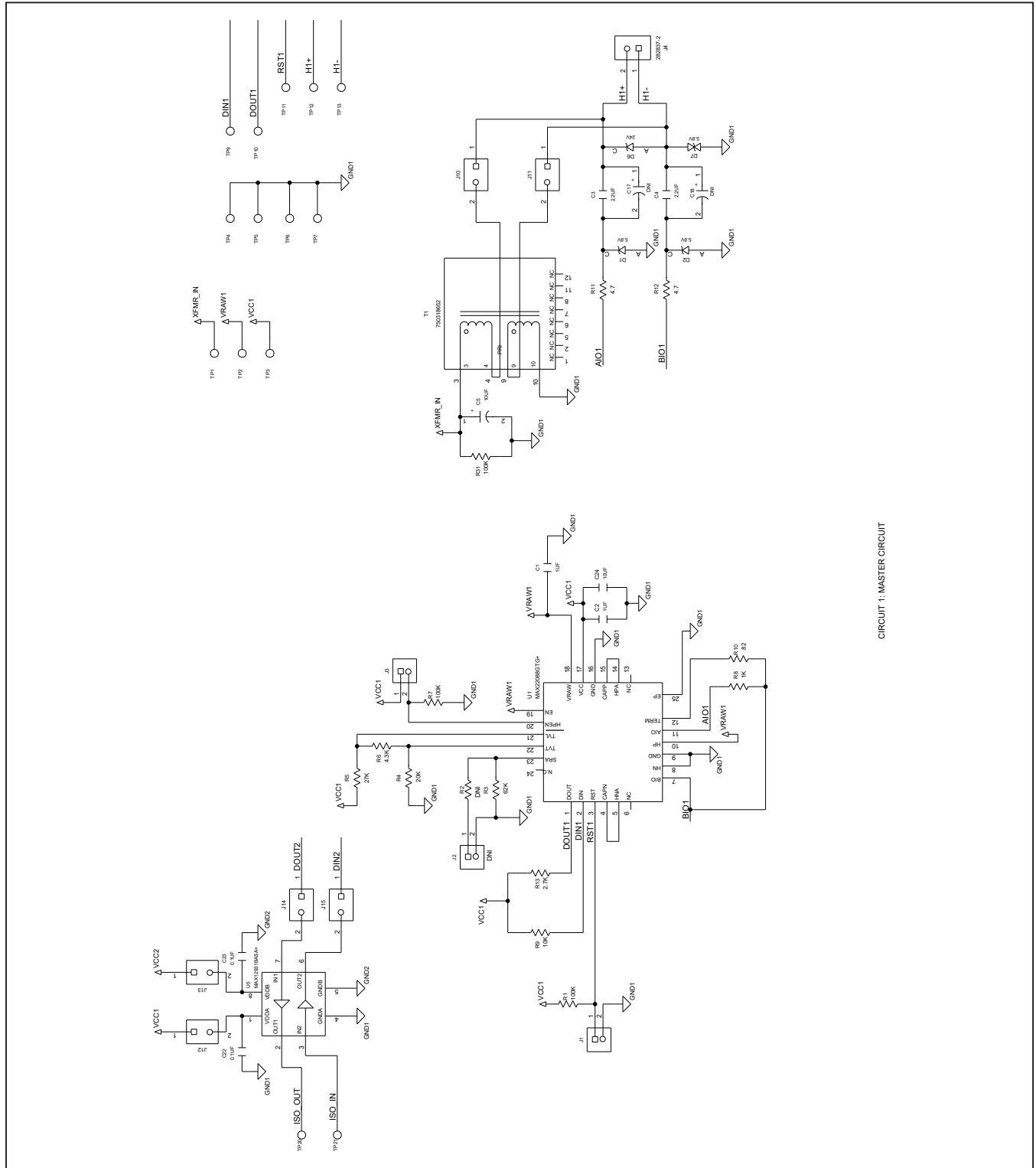

CIRCUIT 1: MASTER CIRCUIT

MAX22088 EV Kit Schematics (continued)

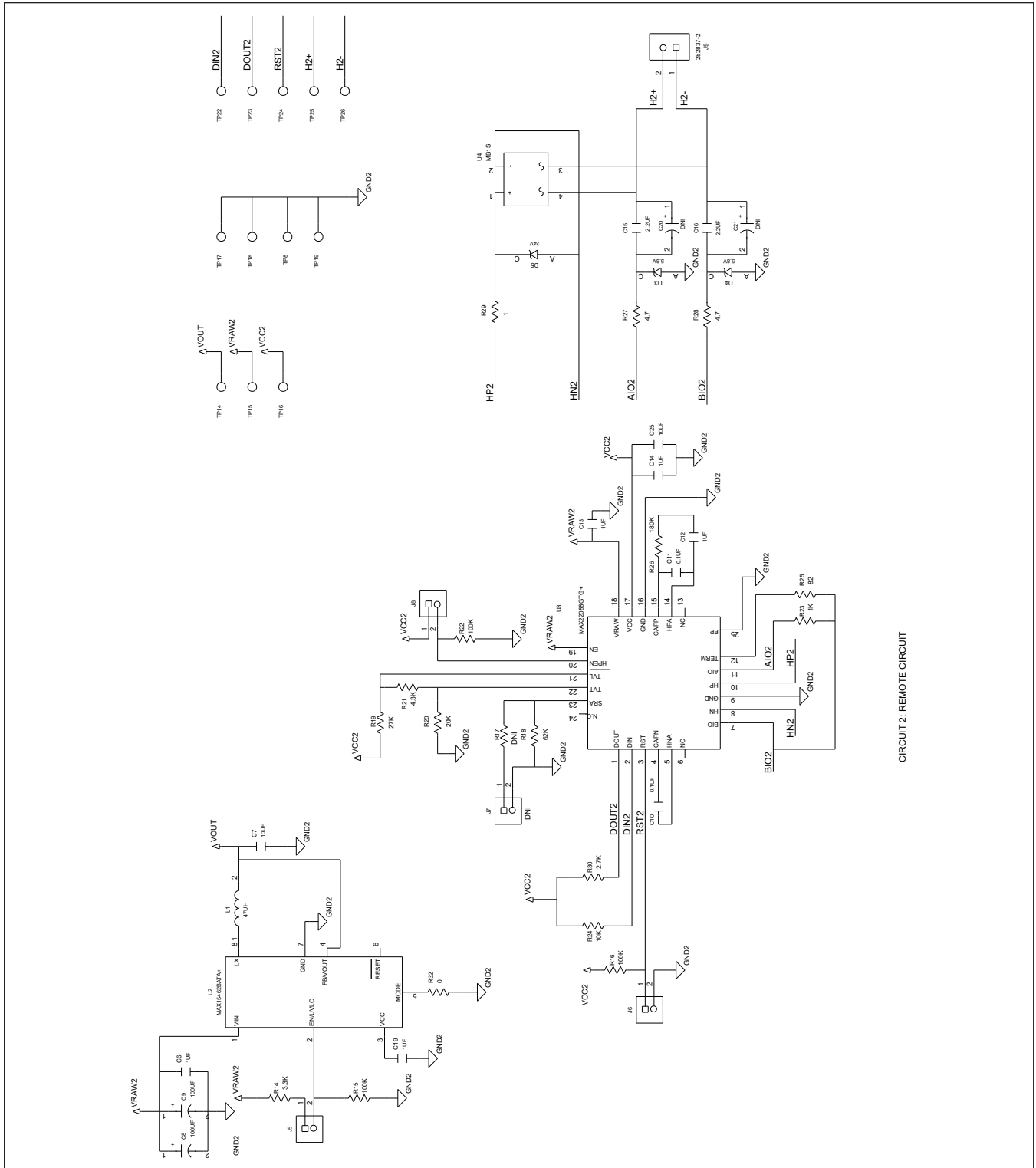

CIRCUIT 2: REMOTE CIRCUIT



MAX22088 EV Kit PCB Layout

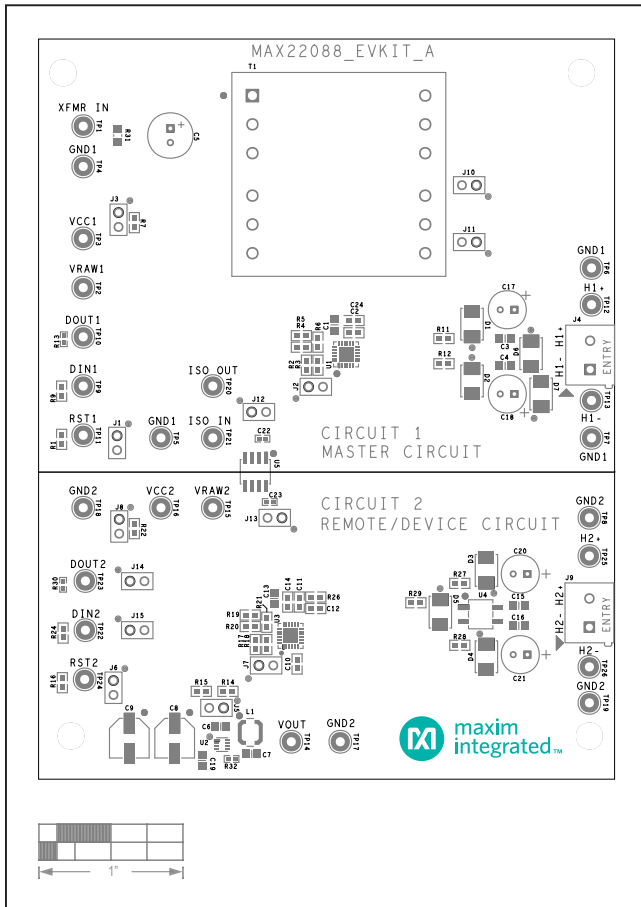

MAX22088 EV Kit—Top Silkscreen

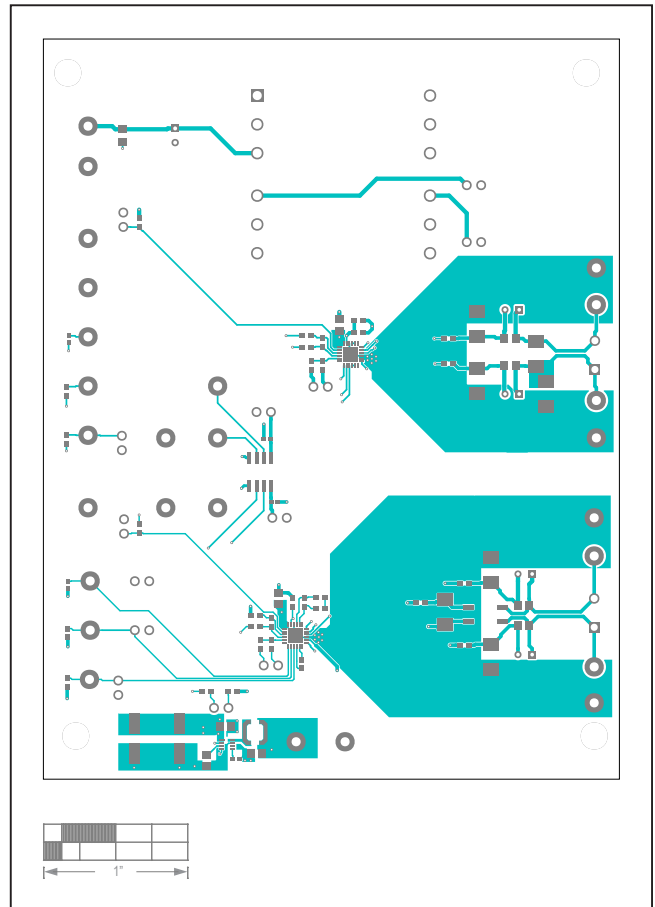

MAX22088 EV Kit—Top Layer

MAX22088 EV Kit PCB Layout (continued)

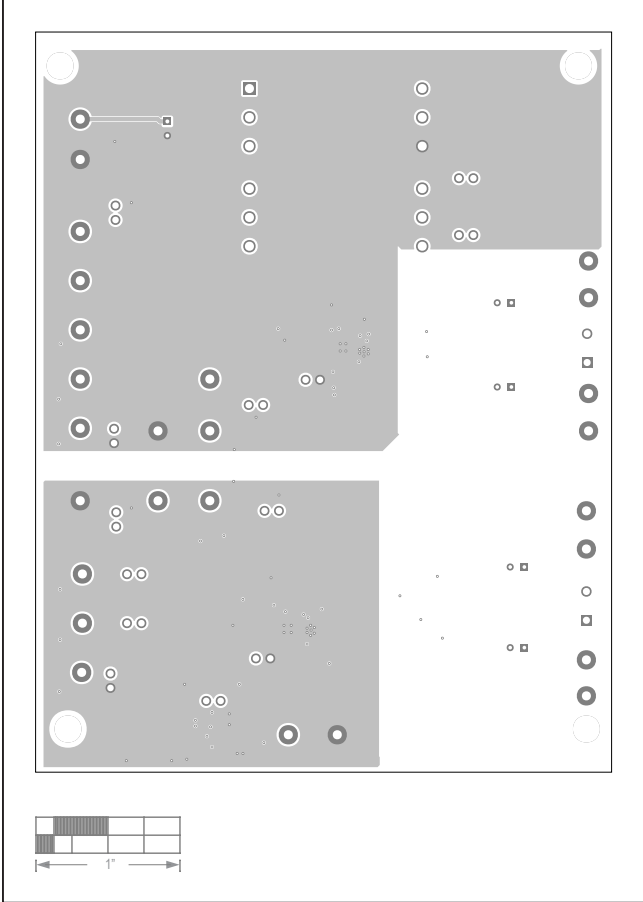

MAX22088 EV Kit—Internal Layer 2

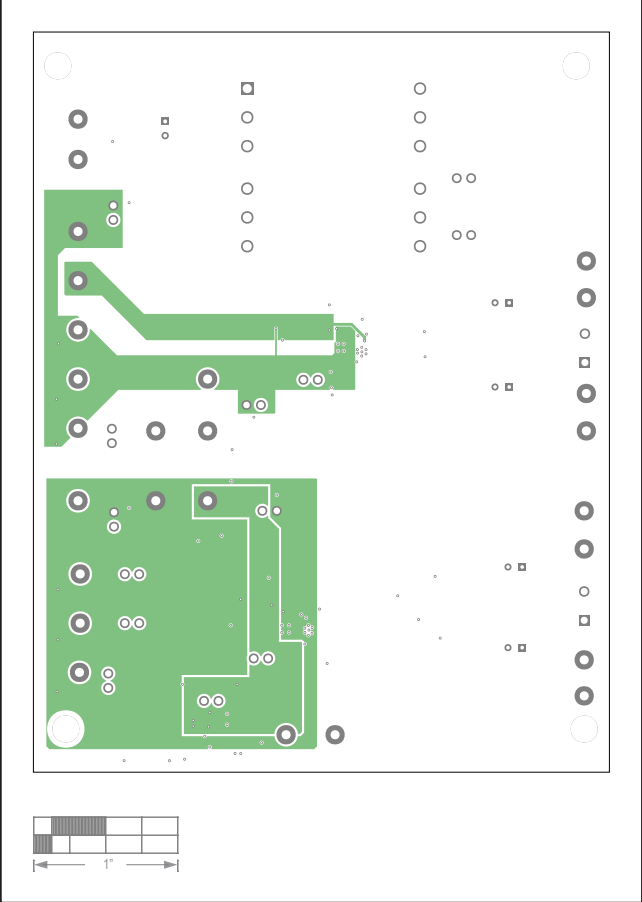

MAX22088 EV Kit—Internal Layer 3

MAX22088 EV Kit PCB Layout (continued)

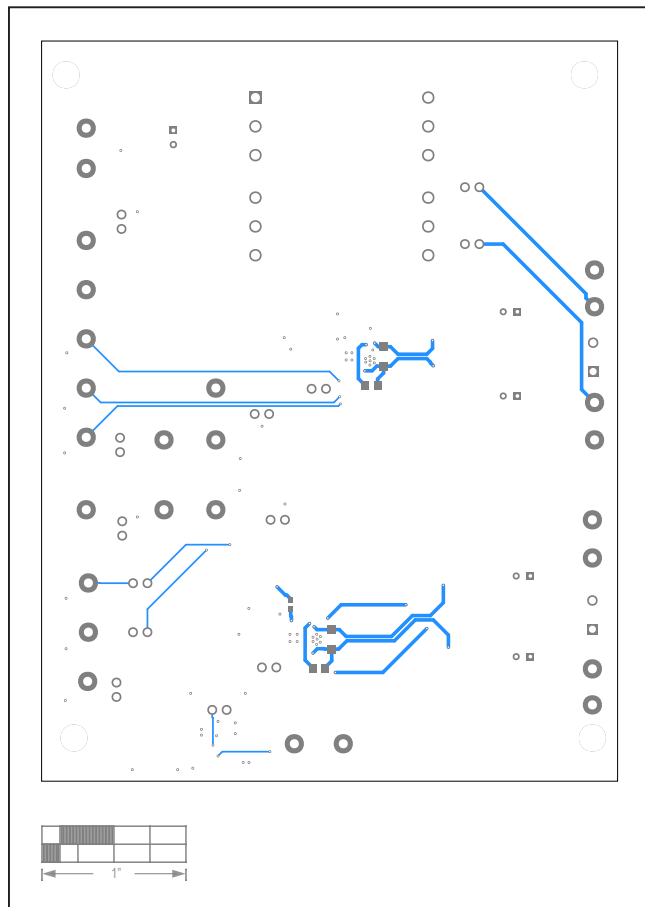

MAX22088 EV Kit—Bottom Layer

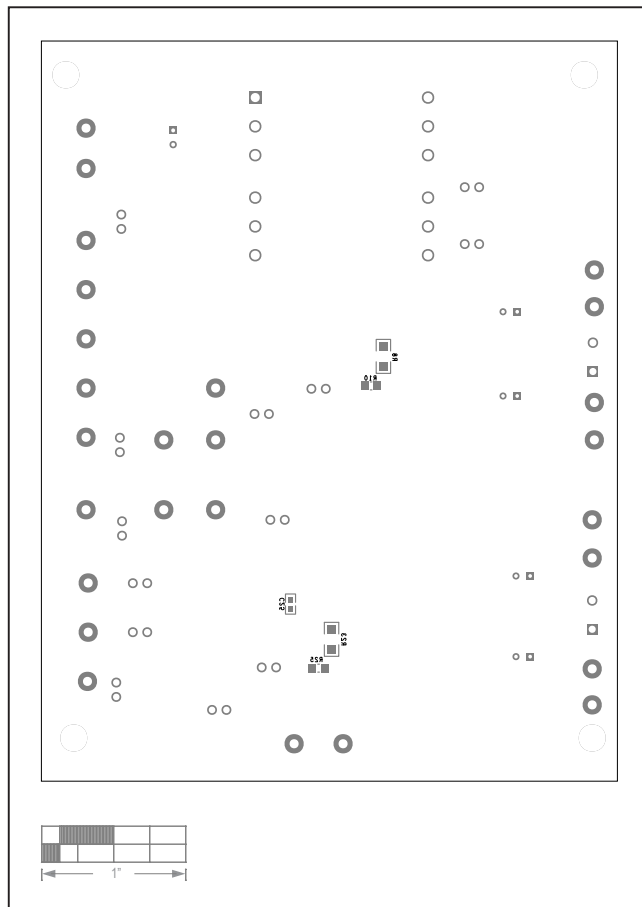

MAX22088 EV Kit—Bottom Silkscreen

## Revision History

REVISION NUMBER	REVISION DATE	DESCRIPTION	PAGES CHANGED
0	02/20	Initial release	—
1	4/20	Updated the <i>General Description, Features, MAX22088 EV Kit Block Diagram, Detailed Description of Hardware, Home Bus System, Master Circuit, Remote/Device Circuit, Master and Remot/Device Grounds, and Isolated Input and Output</i> sections and Figure 1	1, 3–4

For pricing, delivery, and ordering information, please visit Maxim Integrated's online storefront at <https://www.maximintegrated.com/en/storefront/storefront.html>.

*Maxim Integrated cannot assume responsibility for use of any circuitry other than circuitry entirely embodied in a Maxim Integrated product. No circuit patent licenses are implied. Maxim Integrated reserves the right to change the circuitry and specifications without notice at any time.*

## X-ON Electronics

Largest Supplier of Electrical and Electronic Components

*Click to view similar products for [Other Development Tools](#) category:*

*Click to view products by [Maxim](#) manufacturer:*

Other Similar products are found below :

[BK0004](#) [BK0012](#) [MAX9684EVKIT#](#) [EVAL01-HMC749LC3C](#) [410-320](#) [TPD6F002-Q1EVM](#) [TS9002DB](#) [118777-HMC722LC3C](#) [118777-HMC723LC3C](#) [DC1765A-A](#) [125614-HMC851LC3C](#) [DC2062A-A](#) [LMH6321MR-EVAL/NOPB](#) [EVAL01-HMC747LC3C](#) [4537](#) [DK-M3F-1.8-TRK-1.5-S](#) [DK-M3-FS-1.8-1.5-M12/16](#) [DK-M3-LS-1.8-6](#) [ADALP2000](#) [EVAL-CN0202-SDPZ](#) [EVAL-CN0203-SDPZ](#) [EVAL-CN0204-SDPZ](#) [EVAL-CN0209-SDPZ](#) [EVAL-CN0229-SDPZ](#) [EVAL-CN0251-SDPZ](#) [EVAL-CN0272-SDPZ](#) [EVAL-CN0301-SDPZ](#) [EVAL-CN0355-PMDZ](#) [EVAL-CN0364-SDPZ](#) [EVAL-SDP-CB1Z](#) [MAX4951AEEVKIT+](#) [MAXREFDES60#](#) [BK0010](#) [EFIELDDEV](#) [PD70224EVB](#) [MIKROE-3319](#) [MIKROE-3357](#) [MIKROE-4048](#) [MIKROE-1370](#) [MIKROE-1899](#) [MIKROE-1901](#) [MIKROE-1910](#) [MIKROE-1917](#) [MIKROE-1993](#) [MIKROE-3116](#) [MIKROE-957](#) [BB-GEVK](#) [NCS2200AGEVB](#) [27115](#) [64019](#)