

## MAX22195 Evaluation Kit

Evaluates: MAX22195

### General Description

The MAX22195 evaluation kit (EV kit) provides the hardware necessary to evaluate the MAX22195 high-speed, octal, industrial digital input with parallel output device. The MAX22195 EV kit provides terminal blocks for all 8 inputs and a header for all 8 outputs for easy monitoring and evaluation. Eight field-side LEDs are provided to indicate the input status, and a READY LED to indicate the MAX22195 is operating normally.

**Ordering Information** appears at end of data sheet.

### Features

- Easy Evaluation of the MAX22195
- Parallel Output for Simultaneous Signal Delivery
- Configurable External VDD24 Voltage Monitoring
- Configured for IEC 61131-2 Type 1, 3
- Robust Design  $\pm 2\text{kV}$  Surge Tolerant Line-to-Line
- Withstand  $\pm 8\text{kV}$  Contact ESD,  $\pm 15\text{kV}$  Air Gap ESD
- Fully Assembled and Tested
- Proven PCB Layout
- RoHS Compliant

### MAX22195 EV Kit Photo

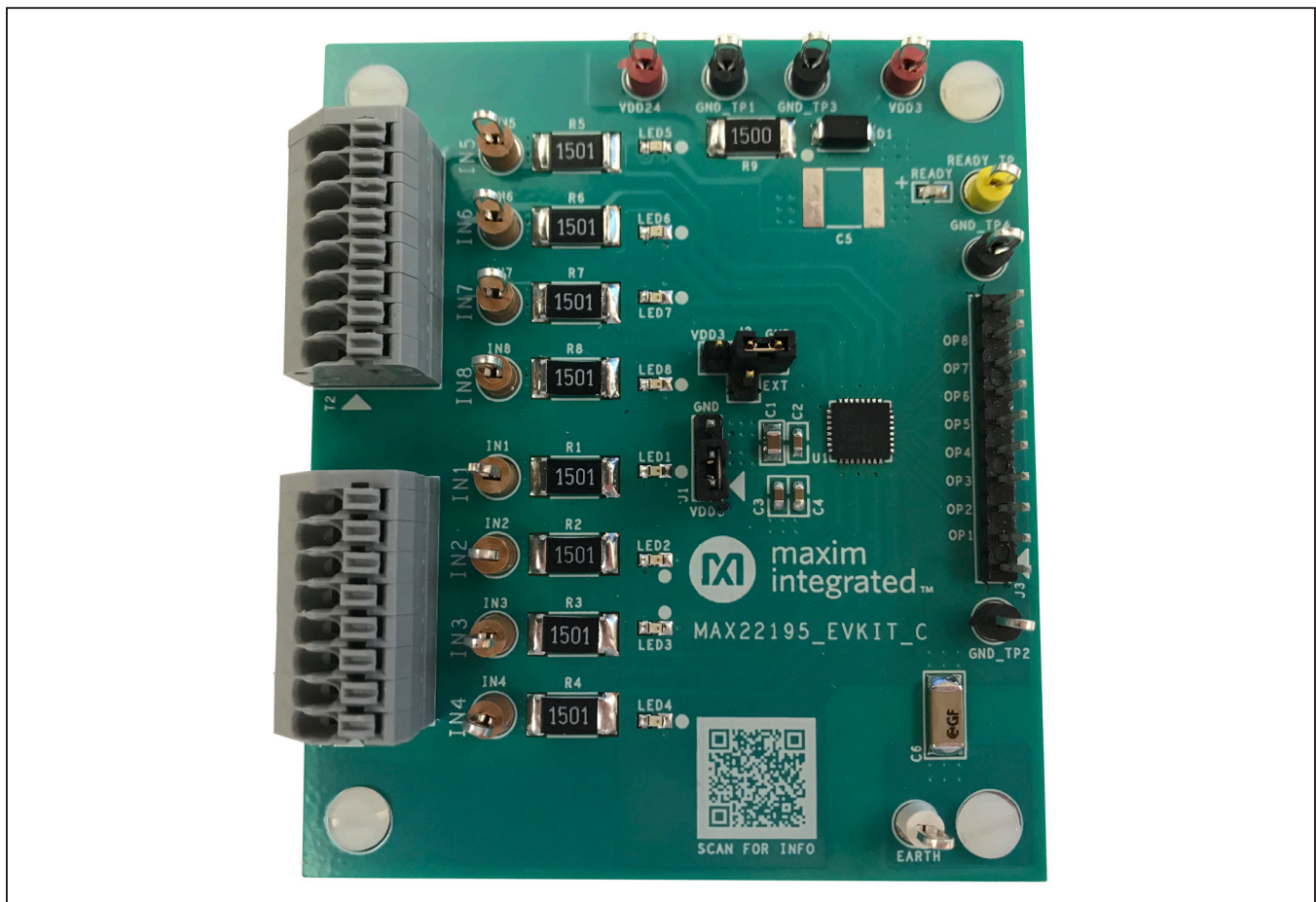

System Block Diagram

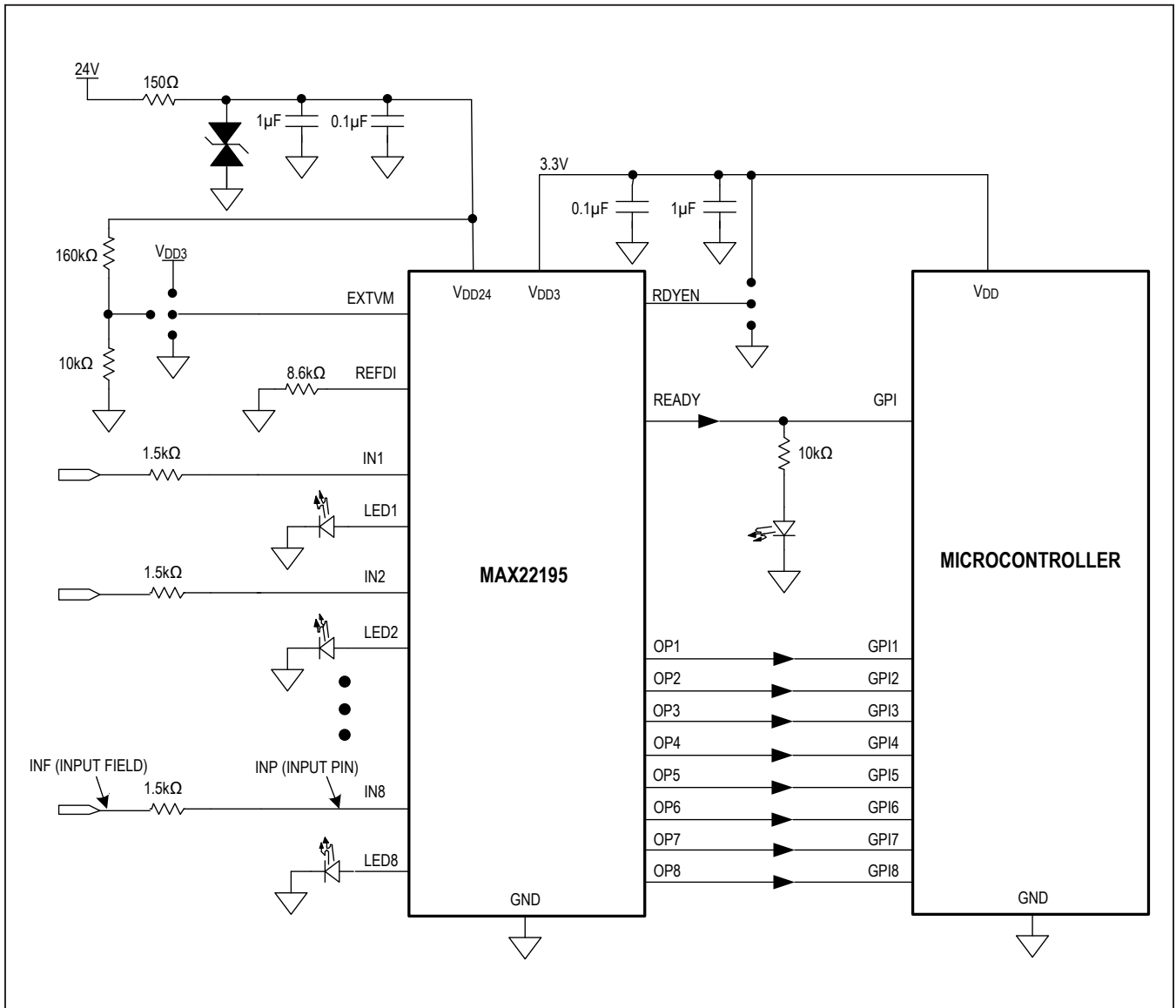

## Quick Start

### Required Equipment

- MAX22195 EV kit
- Two 24V DC voltage supplies
- Oscilloscope

### Procedure

The EV kit is fully assembled and ready for evaluation. The MAX22195 is configured for eight Type 1 or Type 3 inputs (Terminal Blocks T1 and T2). Follow the steps below to verify the MAX22195 operation.

- 1) Verify all jumper settings are in default position from [Table 1](#).
- 2) For initial testing, the MAX22195 EV kit is powered by a 24V DC voltage supply at VDD24 and GND.
- 3) Connect the DC power supply between the EV kit's VDD24 and GND\_TP1 test points. Set the DC power supply output to 24V, and then enable the output. Observe that, READY LED (yellow) on the EV kit is turned on, indicating the EV kit is powered up.
- 4) Connect the other 24V DC voltage supply between pin 8 and pin 7 of T1, or between IN1 and GND\_TP2 test points. Connect the oscilloscope probe to header J3, OP1 (pin 2) and GND (pin 1 or 10).
- 5) Set the DC power supply to 24V, and then enable the output. Observe that LED1 (green) is on and OP1 logic output transitions to high (high level is about 3.3V) on the oscilloscope.

**NOTE:** On the MAX22195 EV kit, the sequence of the input test points from top to bottom is as follows: IN5, IN6, IN7, IN8, IN1, IN2, IN3, and IN4. IN1 is located at the middle of the left side. Refer to the [MAX22195 EV Kit Schematic](#) and [Layout](#) for details.

## Detailed Description of Hardware

The MAX22195 EV kit provides a proven layout for an 8-channel digital input solution with parallel output using the MAX22195. The EV kit supports IEC 61131-2 Type 1, 3 operation and can be configured to support Type 2. This flexibility makes it easier to evaluate the system performance of the MAX22195.

### Power Supply

The EV kit is powered by the 24V external DC supply, connected to VDD24 and GND\_TP1 test points. The MAX22195 has an integrated regulator to provide 3.3V output at VDD3 which can be used to power the digital isolators and other field-side circuits. Alternatively, if an external 24V DC supply is not available, the device can be powered using an external 3.0V–5.5V DC supply through the VDD3 and GND\_TP3 test points while leaving VDD24 test point unconnected (refer to [Table 1](#) for jumper settings).

### RDYEN and READY Monitor

The READY is an open-drain PMOS output to indicate that the MAX22195 is working properly. A READY LED is provided on the EV kit as a visual indicator of the signal status. When READY is low, the READY LED is off indicating that the device is not ready for normal operation. The READY output can also be monitored on READY\_TP test point.

The RDYEN is used to enable or disable the READY output. Jumper J1 is provided on the EV kit: set J1 to 1-2 to enable the READY signal, set J1 to 2-3 to disable the READY signal (refer to [Table 1](#) for jumper settings).

**Table 1. MAX22195 EV Kit Jumper Settings**

JUMPER	SHUNT POSITION	DESCRIPTION
J1	1–2*	Connect RDYEN to VDD3 to enable READY output
	2–3	Connect RDYEN to GND to disable the READY output
J2	1–2*	Connect EXTVM to GND to use internal threshold (14V, typical) for VDD24 voltage monitoring
	1–3	Connect EXTVM to external resistor divider to set external threshold for VDD24 voltage monitoring
	1–4	Connect EXTVM to VDD3 to disable VDD24 voltage monitoring at READY pin if the device is powered by VDD3

\*Default Position

### External VDD24 Voltage Monitor

The EXTVM pin can be connected in 3 ways on the EV kit using jumper J2. Connect J2 to 1-2 to use internal threshold (14V, typical) for VDD24 voltage monitoring. Connect J2 to 1-4 to disable VDD24 voltage monitoring at READY pin if the EV kit is powered by VDD3 using an external DC supply. Connect J2 to 1-3 to use external resistive divider (R12 and R13) to set the external threshold for VDD24 voltage monitoring. The default R12 and R13 values set the VDD24 threshold to about 14V, typical. If other VDD24 threshold is desired, resistors R12 and R13 can be changed accordingly. Refer to the MAX22195 IC data sheet for details.

### Type 1, 3 Inputs

The MAX22195 EV kit is configured to support the trip points (voltage and current) to satisfy the requirements of IEC 61131-2 Type 1 and Type 3 inputs. Resistor R11 sets the current limit value at 2.40mA and input resistors R1-R8 set the voltage thresholds to ensure compliance. The input resistors R1-R8 are 1.5k $\Omega$ , 1.5W pulse withstanding resistors to support IEC 61000-4-5 Surge Tolerance up to  $\pm$ 1kV line-to-ground. A separate LED for each input port indicates the status of each input.

### Type 2 Inputs

The MAX22195 EV kit can be configured to support Type 2 inputs. Type 2 inputs require a higher current limit (6mA, minimum). This can be achieved by connecting two MAX22195 inputs in parallel. The current limit for each channel is set to a nominal 3.97mA by changing resistor R11 to 5.2k $\Omega$ . To set the input voltage thresholds correctly, input resistors R1-R8 need to be changed to 1k $\Omega$ , 1.5W pulse withstanding resistors. Install resistors R14 to R17, 0 $\Omega$ , to create a pair of inputs. Refer to the MAX22195 IC data sheet for details.

### REFDI Layout

The REFDI resistor is used to set the required input current limit of all input channels. Care must be taken during the layout that the REFDI resistor and REFDI trace are routed far away from all field input traces, especially IN8, to limit the high voltage transients such as electrical fast transients or surge pulses to be coupled into REFDI circuitry. A ground plane is recommended to be placed between the REFDI trace and input traces to better shield the noise. On the MAX22195 EV kit, the REFDI resistor R11 is placed on the bottom layer while all input traces are routed on the top layer with GND layer in between. The REFDI via and trace are surrounded by solid ground plane to isolate them from input traces. Refer to the [MAX22195 EV Kit PCB Layout Diagrams](#) for more details.

### IEC 61000-4 Immunity Compliance

The typical application for the MAX22195 requires it to pass basic transient immunity standards as defined by IEC 61000-4-x, covering -2 for Electrostatic Discharge (ESD), -4 for Electrical Fast Transient/Burst (EFT), and -5 for Surge Immunity. The MAX22195 EV kit includes circuitry to support testing to these standards to support  $\pm$ 2kV Line-to-Line Surge,  $\pm$ 8kV Contact ESD, and  $\pm$ 15kV Air Gap ESD. Pulse withstanding Resistor R9 and TVS D1 (SMAJ33A) provide protection from Surge and ESD voltage applied through VDD24. C6 is a 1000pF safety rated Y capacitor placed between Protective Earth (PE) and field ground (GND) to improve transient immunity (EFT). Refer to [Table 2](#) for MAX22195 EV kit transient immunity test results.

**Table 2. MAX22195 EV Kit Transient Immunity Test Results**

TEST		CONDITIONS	RESULT	
Surge	Line-to-Line	IEC 61000-4-5, 1.2/50µs pulse, 40Ω+0.5µF CDN, minimum 1kΩ resistor in series with IN1-IN8	±2kV	
	Line-to-Ground	IEC 61000-4-5, 1.2/50µs pulse, 40Ω+0.5µF CDN, minimum 1kΩ resistor in series with IN1-IN8	±1kV	
	VDD24-to-Ground	IEC 61000-4-5, 1.2/50µs pulse, TVS SMAJ33A (40Ω CDN) or SM30T39AY (0Ω CDN) between VDD24 and GND	±1kV	
EFT	Field Input	IEC 61000-4-4, 5kHz/100kHz, 15ms/0.75ms burst time, 300ms burst period, 1000pF Y capacitor between GND and Earth	±2kV	Criterion A: READY and OP1–OP8 operate without degradation of performance
			±4kV	Criterion B: OP1–OP8 operate without degradation of performance; READY signal is corrupted
	VDD24	IEC 61000-4-4, 5kHz/100kHz, 15ms/0.75ms burst time, 300ms burst period, TVS SMAJ33A or SM30T39AY between VDD24 and GND, 1000pF Y capacitor between GND and Earth	±4kV	Criterion A: READY and OP1–OP8 operate without degradation of performance
ESD	Field Input, Contact Discharge	IEC 61000-4-2, minimum 1kΩ resistor in series with IN1-IN8	±8kV	
	Field Input, Air-Gap Discharge	IEC 61000-4-2, minimum 1kΩ resistor in series with IN1-IN8	±15kV	
	VDD24, Contact Discharge	IEC 61000-4-2, TVS SMAJ33A or SM30T39AY between VDD24 and GND	±8kV	
	VDD24, Air-Gap Discharge	IEC 61000-4-2, TVS SMAJ33A or SM30T39AY between VDD24 and GND	±15kV	

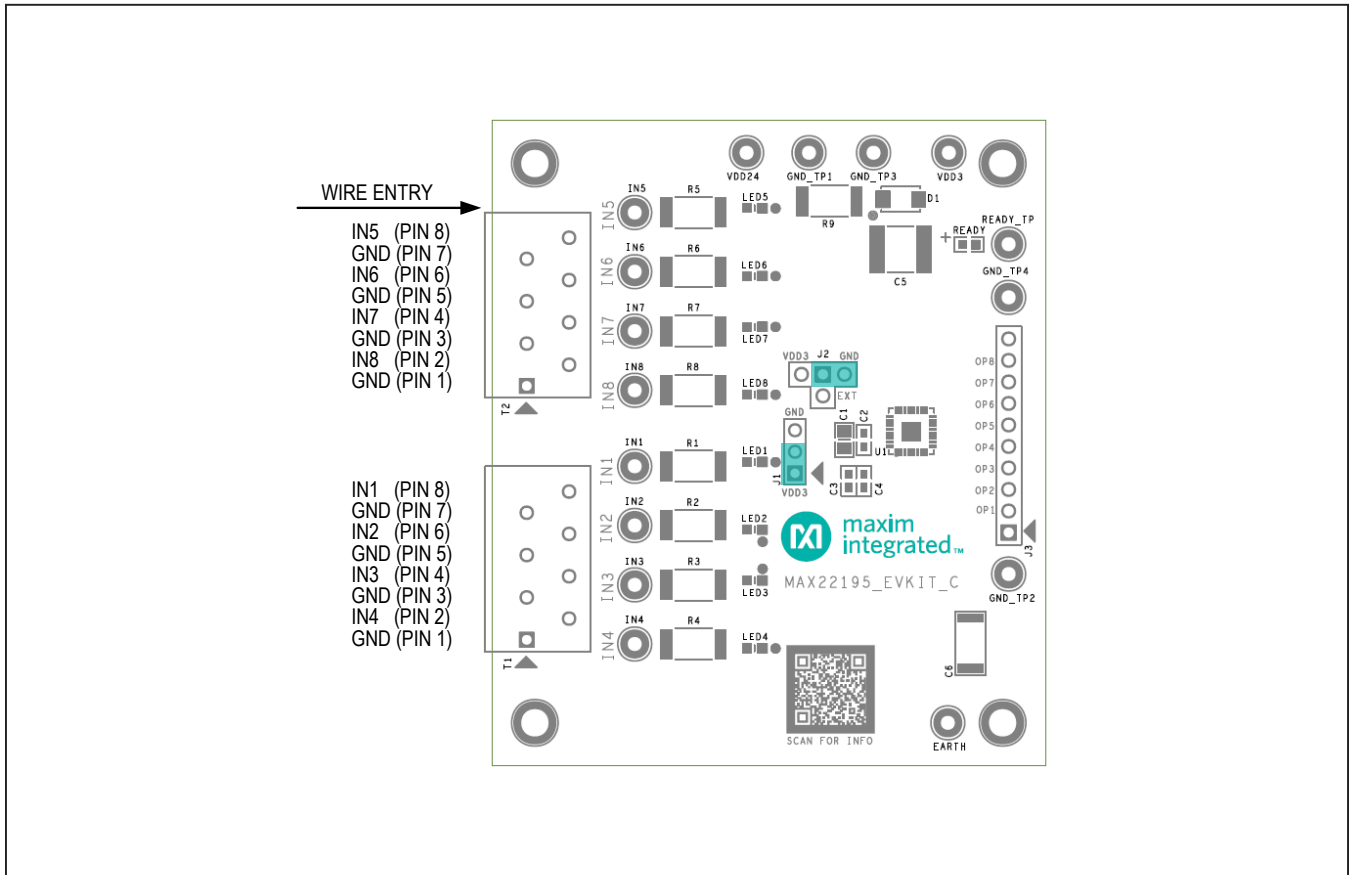

Figure 1. Terminal Block Connection and Input Test Points on the MAX22195 EV Kit

### Ordering Information

PART	TYPE
MAX22195EVKIT#	EV Kit with MAX22195ATJ+ installed

#Denotes RoHS compliant

MAX22195 EV Kit Bill of Materials

ITEM	REF DES	DNI/DNP	QTY	MFG PART #	MANUFACTURER	VALUE	DESCRIPTION
1	C1	-	1	C2012X7S2A105K125AB;GRJ21BC72A105KE11;CGA4J3X7S2A105K125AB;GRM21BC72A105KE01	TDK;MURATA;TDK	1UF	CAPACITOR; SMT (0805); CERAMIC CHIP; 1UF; 100V; TOL=10%; TG=-55 DEGC TO +125 DEGC; TC=X7S
2	C2, C4	-	2	CC0603KRX7R08B104;GRM188R72A104KA35;GCJ188R72A104KA01;HMK107B7104KA;06031C104KAT2A	YAGEO;MURATA;MURATA;TAIYO YUDEN;AVX	0.1UF	CAPACITOR; SMT (0603); CERAMIC CHIP; 0.1UF; 100V; TOL=10%; TG=-55 DEGC TO +125 DEGC; TC=X7R
3	C3	-	1	C1608X7R1V105K080AC;CGA3E1X7R1V105K080AC	TDK;TDK	1UF	CAPACITOR; SMT (0603); CERAMIC CHIP; 1UF; 35V; TOL=10%; TG=-55 DEGC TO +125 DEGC; TC=X7R
4	C6	-	1	GA352QR7GF102KW01	MURATA	1000PF	CAP: SMT (2211); 1000PF; 10%; 250V; X7R; CERAMIC CHIP
5	D1	-	1	SMAJ33A	VISHAY GENERAL SEMICONDUCTOR	33V	DIODE; TVS; SMA (DO-214AC); VRM=33V; IPP=7.5A
6	EARTH	-	1		5012 KEYSTONE	N/A	TEST POINT; PIN DIA=0.125IN; TOTAL LENGTH=0.445IN; BOARD HOLE=0.063IN; WHITE; PHOSPHOR BRONZE WIRE SILVER PLATE FINISH;
7	GND_TP1-GND_TP4	-	4		5011 KEYSTONE	N/A	TEST POINT; PIN DIA=0.125IN; TOTAL LENGTH=0.445IN; BOARD HOLE=0.063IN; BLACK; PHOSPHOR BRONZE WIRE SILVER PLATE FINISH;
8	IN1-IN8	-	8		5125 KEYSTONE	N/A	TEST POINT; PIN DIA=0.125IN; TOTAL LENGTH=0.445IN; BOARD HOLE=0.063IN; BROWN; PHOSPHOR BRONZE WIRE SILVER PLATE FINISH;
9	J1	-	1	PEC03SAAN	SULLINS ELECTRONICS CORP.	PEC03SAAN	EVKIT PART-CONNECTOR; MALE; THROUGH HOLE; BREAKAWAY; STRAIGHT; 3PINS; -65 DEGC TO +125 DEGC;
10	J2	-	1	TSW-104-07-L-S	SAMTEC	TSW-104-07-L-S	EVKIT PART-CONNECTOR; MALE; THROUGH HOLE; TSW SERIES; SINGLE ROW; STRAIGHT; 4PINS
11	J3	-	1	PEC10SAAN	SULLINS ELECTRONICS CORP.	PEC10SAAN	CONNECTOR; MALE; THROUGH HOLE; BREAKAWAY; STRAIGHT; 10PINS
12	LED1-LED8	-	8	LTST-C193KGKT-5A	LITE-ON ELECTRONICS INC.	LTST-C193KGKT-5A	DIODE; LED; STANDARD; YELLOW-GREEN; SMT (0603); PIV=1.9V; IF=0.005A; -55 DEGC TO +85 DEGC
13	R1-R8	-	8	CRCW25121K50FKEGHP	VISHAY	1.5K	RES; SMT (2512); 1.5K; 1%; +/-100PPM/DEGC; 1.5W
14	R9	-	1	CRCW2512150RFKEGHP	VISHAY	150	RES; SMT (2512); 150; 1%; +/-100PPM/DEGC; 1.5W
15	R10	-	1	CRG0603F10K	TE CONNECTIVITY	10K	RESISTOR; 0603; 10K OHM; 1%; 100PPM; 0.1W; THICK FILM
16	R11	-	1	ERJ-3EKF8661	PANASONIC	8.66K	RESISTOR; 0603; 8.66K OHM; 1%; 100PPM; 0.10W; THICK FILM
17	R12	-	1	ERJ-3EKF1603	PANASONIC	160K	RES; SMT (0603); 160K; 1%; +/-100PPM/DEGC; 0.1W
18	R13	-	1	CRCW060310K0FK;ERJ-3EKF1002	VISHAY DALE;PANASONIC	10K	RESISTOR; 0603; 10K; 1%; 100PPM; 0.10W; THICK FILM
19	READY	-	1	LY L29K-H1K2-26-Z	OSRAM	LY L29K-H1K2-26-Z	DIODE; LED; LY L29K SERIES; SMARTLED; YELLOW; SMT (1608); VF=1.8V; IF=0.02A
20	READY_TP	-	1		5014 KEYSTONE	N/A	TEST POINT; PIN DIA=0.125IN; TOTAL LENGTH=0.445IN; BOARD HOLE=0.063IN; YELLOW; PHOSPHOR BRONZE WIRE SILVER PLATE FINISH;
21	SU1, SU2	-	2	SX1100-B;SX1100-B;STC02SYAN	KYCON;KYCON;SULLINS ELECTRONICS CORP.	SX1100-B	TEST POINT; JUMPER; STR; TOTAL LENGTH=0.24IN; BLACK; INSULATION=PBT;PHOSPHOR BRONZE CONTACT=GOLD PLATED
22	T1, T2	-	2	250-408	WAGO	250-408	CONNECTOR; FEMALE; THROUGH HOLE; COMPACT TERMINAL STRIP WITH PUSH BUTTON; STRAIGHT; 8PINS
23	U1	-	1	MAX22195ATJ+	MAXIM	MAX22195ATJ+	EVKIT PART - IC; HIGH-SPEED; OCTAL; DI W PARALLEL OUTPUT; TQFN32-EP; PACKAGE CODE: T3255Y-6; PACKAGE LAND PATTERN: 90-0603; PACKAGE OUTLINE: 21-0140
24	VDD3, VDD24	-	2		5010 KEYSTONE	N/A	TEST POINT; PIN DIA=0.125IN; TOTAL LENGTH=0.445IN; BOARD HOLE=0.063IN; RED; PHOSPHOR BRONZE WIRE SIL;
25	PCB	-	1	MAX22195	MAXIM	PCB	PCB-MAX22195
26	MTH1-MTH4	DNI	4	1902B	GENERIC PART	N/A	STANDOFF; FEMALE-THREADED; HEX; 4-40IN; 3/8IN; NYLON
27	MTH1-MTH4	DNI	4	P440.375	GENERIC PART	N/A	MACHINE SCREW; SLOTTED; PAN; 4-40IN; 3/8IN; NYLON
28	C5	DNI	1	CGA9N3X7S2A106K230KB	TDK	10UF	CAP: SMT (2220); 10UF; 10%; 100V; X7S; CERAMIC CHIP
29	R14-R17	DNP	0	CRCW25120000Z0EGHP	VISHAY DRALORIC	0	RES; SMT (2512); 0; JUMPER; 1.5W
30	R18-R25	DNP	0	CRCW06030000Z5;MCR03EZPJ000;ERJ-3GEYOR00	VISHAY DALE;ROHM;PANASONIC	0	RESISTOR; 0603; 0 OHM; 0%; JUMPER; 0.10W; THICK FILM
TOTAL			62				





MAX22195 EV Kit PCB Layout Diagrams

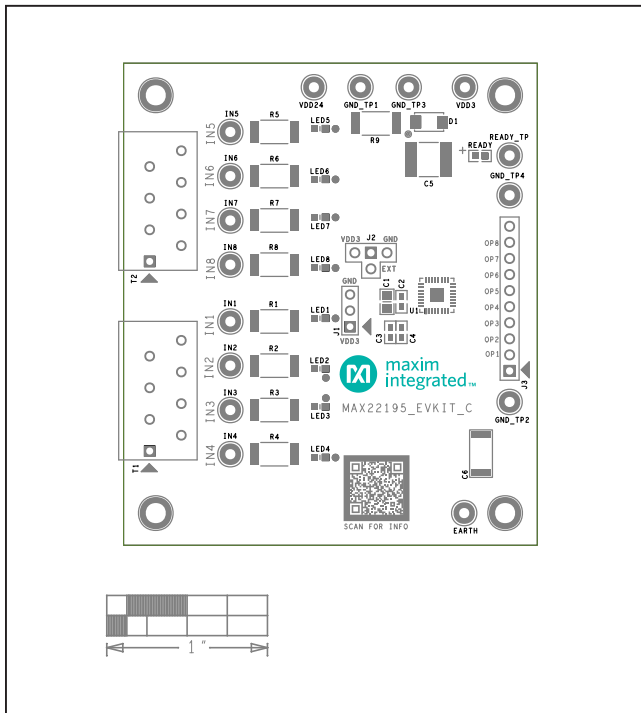

MAX22195 EV Kit—Top Silkscreen

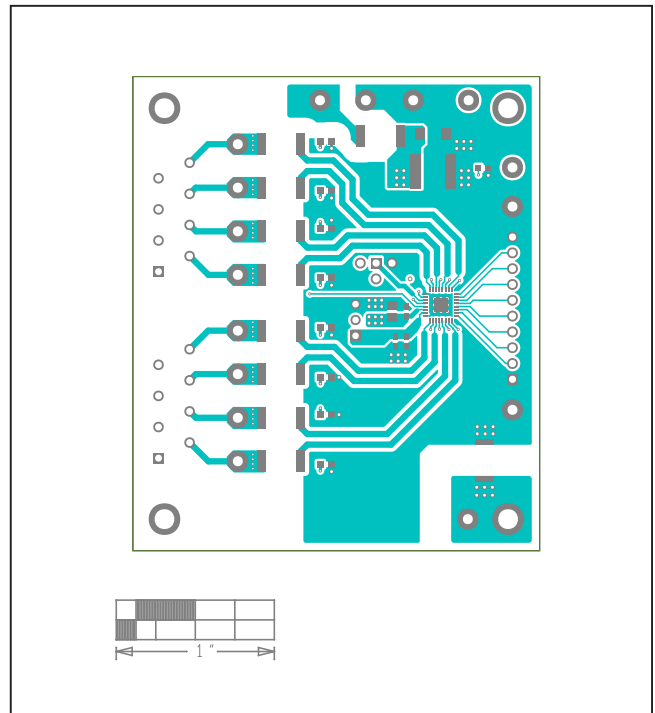

MAX22195 EV Kit—Top Layer

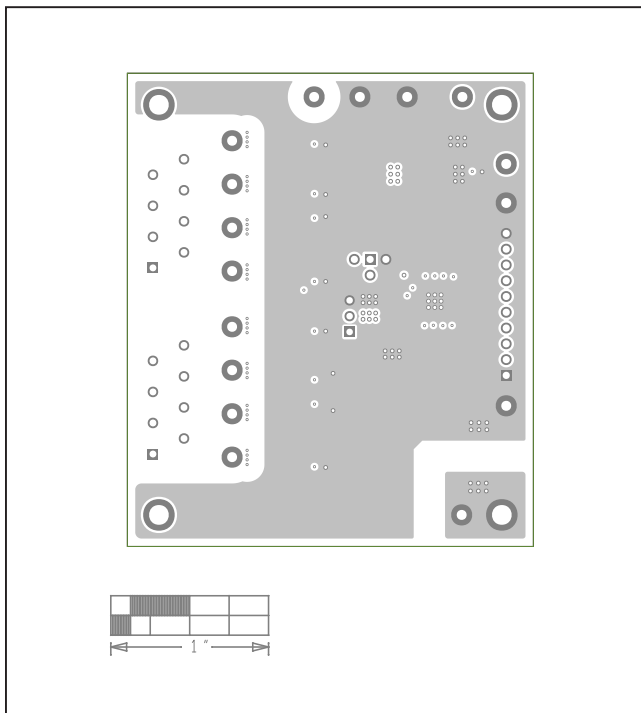

MAX22195 EV Kit—Internal 2

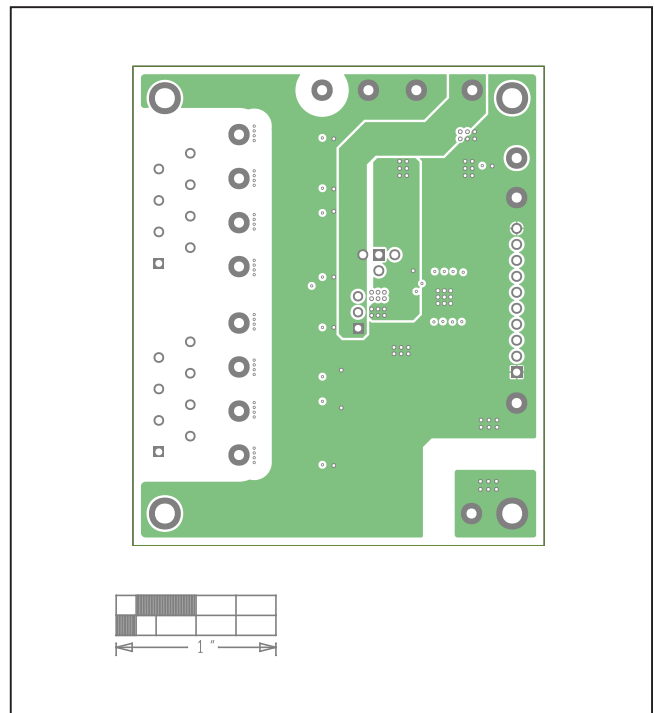

MAX22195 EV Kit—Internal 3

MAX22195 EV Kit PCB Layout Diagrams (continued)

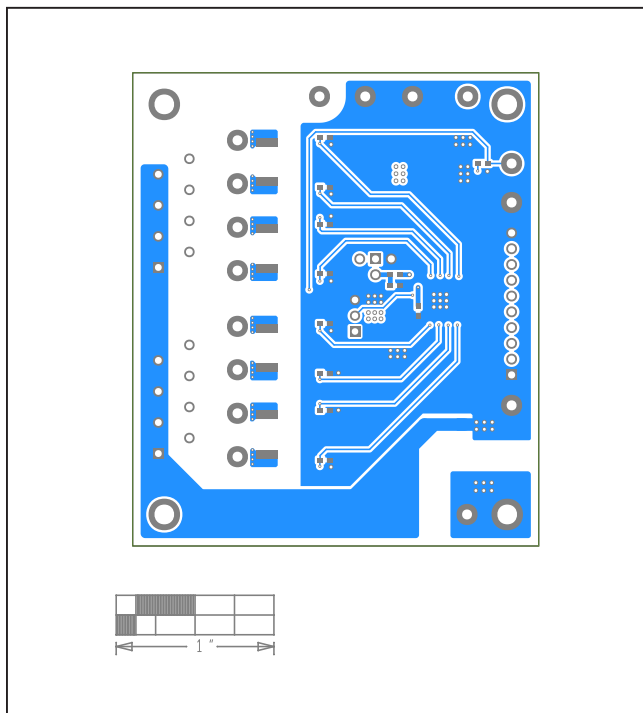

MAX22195 EV Kit—Bottom Layer

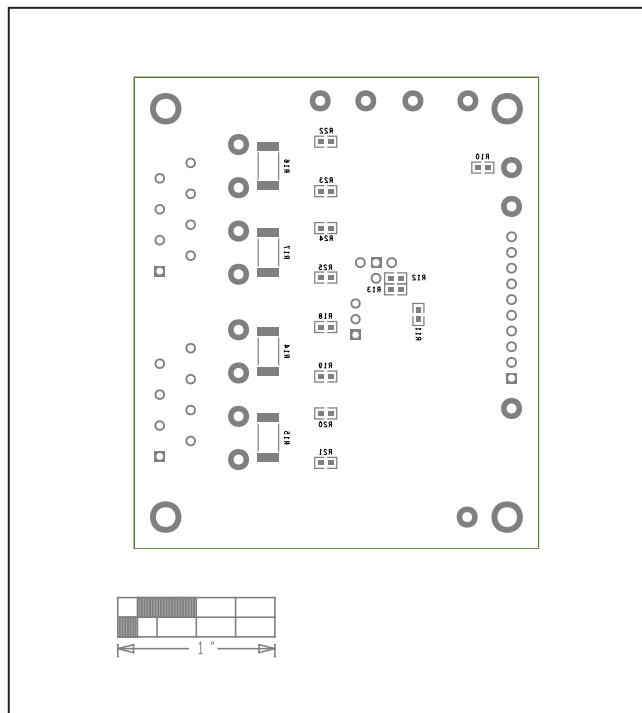

MAX22195 EV Kit—Bottom Silkscreen

## Revision History

REVISION NUMBER	REVISION DATE	DESCRIPTION	PAGES CHANGED
0	8/18	Initial release	—
1	5/19	Updated <i>Procedure, Detailed Description of Hardware, Power Supply, RDYEN and READY Monitor, External VDD24 Voltage Monitor, Type 1, 3 Inputs, Type 2 Inputs and IEC61000-4 Immunity Compliance</i> sections, and Table 1 and Table 2; replaced the <i>EV Kit Photo, Figure 1, Bill of Materials, Schematic, and PCB Layout</i>	1, 3–9

For pricing, delivery, and ordering information, please visit Maxim Integrated's online storefront at <https://www.maximintegrated.com/en/storefront/storefront.html>.

Maxim Integrated cannot assume responsibility for use of any circuitry other than circuitry entirely embodied in a Maxim Integrated product. No circuit patent licenses are implied. Maxim Integrated reserves the right to change the circuitry and specifications without notice at any time.

## X-ON Electronics

Largest Supplier of Electrical and Electronic Components

*Click to view similar products for [Interface Development Tools](#) category:*

*Click to view products by [Maxim](#) manufacturer:*

Other Similar products are found below :

[ADP5585CP-EVALZ](#) [CHA2066-99F](#) [AS8650-DB](#) [MLX80104 TESTINTERFACE](#) [416100120-3](#) [XR18910ILEVB](#) [XR21B1421IL28-0A-EVB](#) [TW-DONGLE-USB](#) [EVAL-ADM2491EEBZ](#) [MAXREFDES23DB#](#) [MAX13235EEVKIT](#) [DFR0257](#) [XR22404CG28EVB](#) [ZLR964122L](#) [ZLR88822L](#) [EVK-U23-01S](#) [EVK-W262U-00](#) [DC327A](#) [PIM511](#) [PIM536](#) [PIM517](#) [DEV-17512](#) [STR-FUSB3307MPX-PPS-GEVK](#) [MAXREFDES177#](#) [EVAL-ADM2567EEBZ](#) [ZSSC3240KIT](#) [MAX9121EVKIT](#) [PIM532](#) [ZSC31010KITV2P1](#) [UMFT4233HPEV](#) [LVDS-18B-EVK](#) [XR20M1170G16-0B-EB](#) [XR20M1170G24-0B-EB](#) [XR20M1172G28-0A-EB](#) [XR20M1172G28-0B-EB](#) [SI871XSOIC8-KIT](#) [1764](#) [1833](#) [1862](#) [EVB-USB82514](#) [ATA6628-EK](#) [ATA6631-EK](#) [EVAL-CN0313-SDPZ](#) [2264](#) [MCP23X17EV](#) [PS081-EVA-HR MODULE](#) [237](#) [SMA2RJ45EVK/NOPB](#) [FR12-0002](#) [MAFR-000455-001](#)