

MAX22563–MAX22566 Evaluation Kits

Evaluates: MAX22563–MAX22566

General Description

The MAX22563–MAX22566 evaluation kits (EV kits) provide a proven design to evaluate the MAX22563–MAX22566, a family of reinforced, six-channel, galvanic digital isolators in a 20-pin SSOP package. Two types of evaluation boards are available to support different channel direction configurations and selectable output default settings of the MAX22563–MAX22566 family. The MAX22565CAEVKIT# is fully assembled and tested, and comes populated with the MAX22565CAAP+ (Figure 1). The MAX2256XAEVKIT# is a generic board that has U1 unpopulated, allowing to select a device from the MAX22563–MAX22566 family (Figure 2). Both evaluation boards support the 20-pin SSOP package type only. See Table 1 for EV kit options.

The MAX22163–MAX22166 and MAX22663–MAX22666 are functionally equivalent to MAX22563–MAX22566, but in different package types. The MAX22163–MAX22166 come in a 16-pin QSOP and MAX22663–MAX22666 in a 16-pin wide SOIC package. The MAX22563–MAX22566 EV kits can be used to evaluate the functionality and electrical performance of the entire family of the devices.

The EV kits should be powered from two independent isolated power supplies with nominal output voltage in the range from 1.71V to 5.5V. To evaluate the electrical parameters of the device without any isolation between the two sides, a single power supply can also be used.

The MAX2256XAEVKIT# comes with U1 unpopulated and supports the following digital isolators: MAX22563BAAP+, MAX22563CAAP+, MAX22564BAAP+, MAX22564CAAP+, MAX22565BAAP+, MAX22565CAAP+, MAX22566BAAP+, and MAX22566CAAP+.

Note: When ordering the MAX2256XA EV kit, request a sample of the desired MAX22563–MAX22566 isolator IC that can be soldered to the PCB.

Features

- Broad Range of Data Transfer Rates from DC to 200Mbps
- MAX22563 with 3:3 Channel Configuration
- MAX22564 with 4:2 Channel Configuration
- MAX22565 with 5:1 Channel Configuration
- MAX22566 with 6:0 Channel Configuration
- SMA Connectors for Easy Connection to External Equipment
- Wide Power Supply Voltage Range from 1.71V to 5.5V
- Guaranteed up to 3.75kVRMS Isolation for 60s
- -40°C to +125°C Temperature Range
- Proven PCB Layout

EV Kit Photos

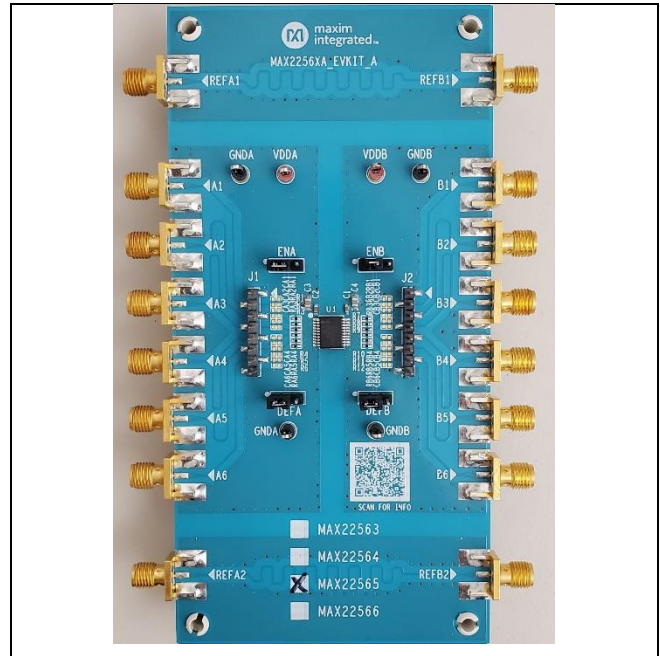

Figure 1. MAX22565CA EV Kit

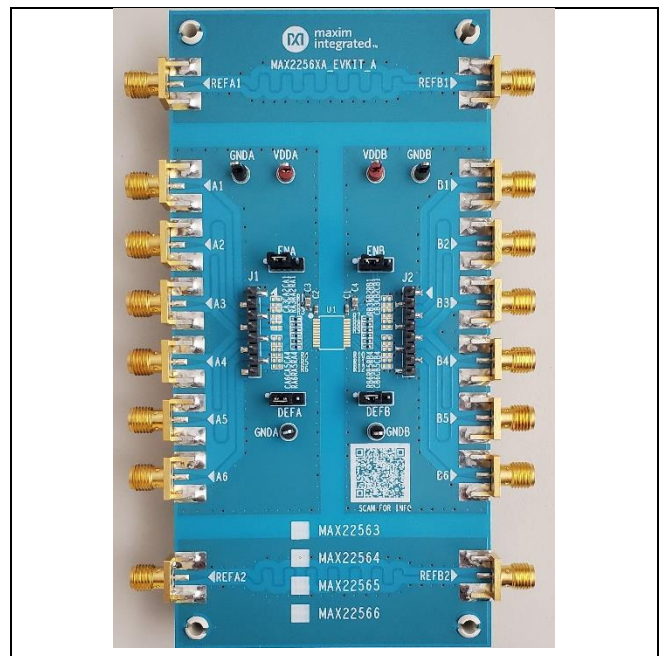

Figure 2. MAX2256XA EV Kit

[Ordering Information](#) appears at end of data sheet.

Quick Start

Required Equipment

- MAX22565CA or MAX2256XA EV kit
- MAX22563–MAX22566 device if U1 is unpopulated on EV kit
- Two DC power supplies with output range of 1.71V to 5.5V
- Signal/function generator
- Oscilloscope

Procedures

The MAX22565CA EV kit is fully assembled and ready for evaluation. The MAX2256XA EV kit has everything except the DUT (U1) installed. The user can install the desired version of the MAX22563–MAX22566 family of reinforced, six-channel, unidirectional digital isolators. Once installed, follow these steps to verify board functionality:

1. Verify jumper settings. See [Table 2](#) for all shunt positions. Jumpers ENA, ENB, DEFA, and DEFB are

in 1-2 position. ENA is open if U1 is installed with the MAX22566.

2. Connect one DC power supply between the EV kit's VDDA and GNDA test points; connect the other DC power supply between VDDB and GNDB test points.
3. Set both DC power supply outputs between 1.71V and 5.5V, and then enable the power supply outputs.

Note: It is also possible to power the EV kits from a single power supply to test electrical parameters, but this invalidates the digital isolation of the IC.

4. Connect the signal/function generator to an input SMA connector or test point of side A and observe the isolated signal on the corresponding side B output using an oscilloscope. On the MAX22565CA EV kit, SMA connectors A1–A5 and B6 are inputs, and SMA connectors B1–B5 and A6 are outputs. See [Table 3](#) for the SMA connector I/O configurations when a different MAX22563–MAX22566 device is installed as U1 on the MAX2256XA EV kit.

Table 1. EV Kit Options

EVKIT PART #	TARGET DEVICE	PACKAGE TYPE	COMMENT
MAX22565CAEVKIT#	MAX22565CAAP+	20-pin SSOP	200Mbps IC Populated
MAX2256XAEVKIT#	Not Populated	20-pin SSOP	Request Samples of Target Device from Maxim Integrated®

Table 2. MAX22565CA and MAX2256XA EV Kits Shunt Positions

CONNECTOR	SHUNT POSITION	DESCRIPTION
SIDE A		
J1	1	Test point or input header for V _{DDA} .
	2	Test point or input header for I/O; same as A1 SMA.
	3	Test point or input header for I/O; same as A2 SMA.
	4	Test point or input header for I/O; same as A3 SMA.
	5	Test point or input header for I/O; same as A4 SMA.
	6	Test point or input header for I/O; same as A5 SMA.
	7	Test point or input header for I/O; same as A6 SMA.
	8	Test point or input header for GNDA.
ENA	1-2*	Connect side A enable pin ENA to V _{DDA} . Side A outputs are enabled when ENA is connected to V _{DDA} .
	2-3	Connect side A enable pin ENA to GNDA. Side A outputs are high-impedance when ENA is connected to GNDA.
	Open	Side A enable pin is not connected when U1 is installed with the MAX22566.
DEFA	1-2*	Connect side A default control pin DEFA to V _{DDA} . Side A output default is set to high when DEFA is connected to V _{DDA} . Jumper DEFA must be set in the same position as DEFB.

	2-3	Connect side A default control pin DEFA to GNDA. Side A output default is set to low when DEFA is connected to GNDA. Jumper DEFA must be set in the same position as DEFB.
SIDE B		
J2	1	Test point or input header for V _{DDB} .
	2	Test point or input header for I/O; same as B1 SMA.
	3	Test point or input header for I/O; same as B2 SMA.
	4	Test point or input header for I/O; same as B3 SMA.
	5	Test point or input header for I/O; same as B4 SMA.
	6	Test point or input header for I/O; same as B5 SMA.
	7	Test point or input header for I/O; same as B6 SMA.
	8	Test point or input header for GNDB.
ENA	1-2*	Connect side B enable pin ENB to V _{DDB} . Side B outputs are enabled when ENB is connected to V _{DDB} .
	2-3	Connect side B enable pin ENB to GNDB. Side B outputs are high-impedance when ENB is connected to GNDB.
DEFB	1-2*	Connect side B default control pin DEFB to V _{DDB} . Side B output default is set to high when DEFB is connected to V _{DDB} . Jumper DEFB must be set in the same position as DEFA.
	2-3	Connect side B default control pin DEFB to GNDB. Side B output default is set to low when DEFB is connected to GNDB. Jumper DEFB must be set in the same position as DEFA.

*Default Configuration.

Table 3. MAX22565CA and MAX2256XA EV Kits Connector Configurations

CONNECTOR	U1 DEVICE			
	MAX22563	MAX22564	MAX22565	MAX22566
SIDE A				
A1 (SMA)	IN1	IN1	IN1	IN1
A2 (SMA)	IN2	IN2	IN2	IN2
A3 (SMA)	IN3	IN3	IN3	IN3
A4 (SMA)	OUT4	IN4	IN4	IN4
A5 (SMA)	OUT5	OUT5	IN5	IN5
A6 (SMA)	OUT6	OUT6	OUT6	IN6
REFA1 (SMA)	I/O on Side A	I/O on Side A	I/O on Side A	I/O on Side A
REFA2 (SMA)	I/O on Side A	I/O on Side A	I/O on Side A	I/O on Side A
SIDE B				
B1 (SMA)	OUT1	OUT1	OUT1	OUT1
B2 (SMA)	OUT2	OUT2	OUT2	OUT2
B3 (SMA)	OUT3	OUT3	OUT3	OUT3
B4 (SMA)	IN4	OUT4	OUT4	OUT4
B5 (SMA)	IN5	IN5	OUT5	OUT5
B6 (SMA)	IN6	IN6	IN6	OUT6
REFB1 (SMA)	I/O on Side B	I/O on Side B	I/O on Side B	I/O on Side B
REFB2 (SMA)	I/O on Side B	I/O on Side B	I/O on Side B	I/O on Side B

Detailed Description of Hardware

The MAX22563–MAX22566 EV kits evaluate the features of the MAX22563–MAX22566, a family of reinforced, six-channel, galvanic digital isolators.

External Power Supplies

Power to the MAX22565CA and MAX2256XA EV kits is derived from two external sources, which can both be between +1.71V and +5.5V. Connect one source between the VDDA and GNDA test points, and the other source between the VDDB and GNDB test points. Each supply can be set independently and can be present over the entire range from +1.71V to +5.5V, regardless of the level or presence of the other supply. The MAX22563–MAX22566 level-shift the data, transmitting them across the isolation barrier.

Six SMA connectors on each side of the board allow easy connections to signal generator(s) and an oscilloscope. A typical test setup is shown in [Figure 3](#).

Decoupling Capacitors

Each power supply is decoupled with a 1 μ F ceramic capacitor in parallel with a 0.1 μ F ceramic capacitor, which are placed close to the U1 VDDA and VDDB pins.

Shunt Positions

Jumpers ENA and ENB are provided to enable or disable the outputs of the MAX22563–MAX22566 isolator channels.

Connect the ENA shunt to VDDA to enable side A outputs or connect to GNDA to disable them. Side A outputs are high-impedance when disabled. Connect the ENB shunt to VDDB to enable side B outputs or connect to GNDB to disable them. Side B outputs are high-impedance when disabled. Leave ENA open if U1 is installed with the MAX22566.

The MAX22563–MAX22566 feature user-selectable default-high or default-low outputs. To configure the default level of both side A and side B outputs to high, connect the DEFA shunt to VDDA and the DEFB shunt to VDDB. To configure the default level of the outputs to low, connect the DEFA shunt to GNDA and the DEFB shunt to GNDB. Ensure the logic state of the DEFA is the same as that for DEFB. Configure the DEFA and DEFB shunts before powering up the board and do not toggle them during normal operation. See [Table 2](#) for all shunt positions and [Table 3](#) for connector configurations.

I/O Traces Impedance Control

The input and output traces of all six isolation channels have an impedance control of 50 Ω . A 20 Ω series resistor is added to all input and output channels; along with the internal series resistance, it can provide 50 Ω impedance matching with external equipment such as function generators or oscilloscopes.

Output Load

Each output has an unpopulated 0402 SMT resistor (RA1–RA6, RB1–RB6) and an unpopulated 0402 SMT capacitor (CA1–CA6, CB1–CB6) to GND_ to allow different loads based on customer requirements.

Calibration Channels

Two reference channels (REFA1–REFB1, REFA2–REFB2) are implemented on the EV kits to help calibrate the test setup for timing measurements such as propagation delay. Measure the propagation delay (t_{PD_REF}) using the reference channel first to determine the delay introduced by the test setup. Measure the propagation delay (t_{PD_ISO}) again using one of the MAX22563–MAX22566 data channels. The calibrated isolator delay is $t_{PD_ISO} - t_{PD_REF}$.

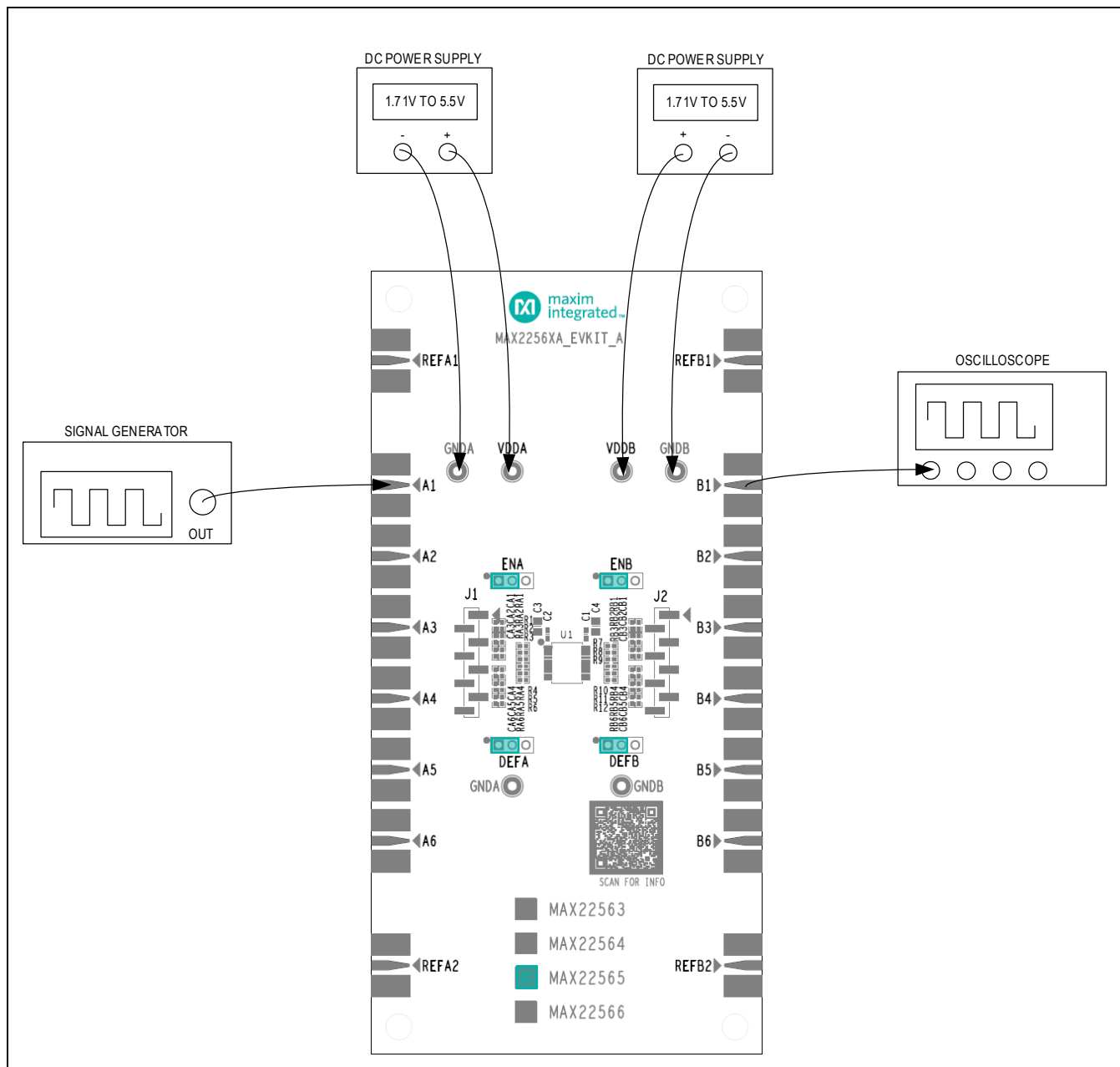

Figure 3. MAX22565CA EV Kit Typical Test Setup

U1 on the MAX2256XA EV Kit

U1 on the MAX2256XAEVKIT# is not installed. The user can install the desired version of the MAX22563–MAX22566 family of six-channel unidirectional digital isolators. The MAX22563–MAX22566 family offers four unidirectional channel configurations. The MAX22566 features all six channels transferring digital signals in one direction. SMA connectors A1–A6 on side A are input connectors and B1–B6 on side B are output connectors if the MAX22566 is installed as U1. The MAX22565 has five channels transmitting data in one direction and one channel transmitting in the opposite direction. SMA connectors A1–A5 and B6 are input connectors and B1–B5 and A6 are output connectors if the MAX22565 is installed as U1. The MAX22564 has four channels transmitting data in one direction and two channels transmitting in the opposite direction. SMA connectors A1–A4 and B5–B6 are input connectors and B1–B4 and A5–A6 are output connectors

if the MAX22564 is installed as U1. The MAX22563 provides three channels in each direction. SMA connectors A1–A3 and B4–B6 are input connectors and B1–B3 and A4–A6 are output connectors if the MAX22563 is installed as U1. See [Table 3](#) for SMA connector I/O configurations with different U1 selection.

When installing U1, make sure pin 1 of the device is mounted onto pin 1 of U1 on the PCB. Pin 1 is located at the upper left corner of U1, denoted by a white dot on the silkscreen.

Ordering Information

PART	TYPE
MAX22565CAEVKIT#	EV Kit with Installed MAX22565CAAP+
MAX2256XAEVKIT#	EV Kit for 20-pin SSOP Package

#Denotes RoHS-compliant.

MAX22563-MAX22566 EV Kit Bill of Materials

ITEM	REF_DES	DNP	QTY	MFG PART #	MANUFACTURER	VALUE	DESCRIPTION
1	A1-A6, B1-B6, REFA1, REFA2, REFB1, REFB2		16	142-0701-851	JOHNSON COMPONENTS	142-0701-851	CONNECTOR; END LAUNCH JACK RECEPTACLE; BOARDMOUNT; STRAIGHT THROUGH; 2PINS;
2	C1, C2		2	CC0603KRX7R0BB 104; GRM188R72A104K A35; HMK107B7104KA;0 6031C104KAT2A; GRM188R72A104K	YAGEO; MURATA; TAIYO YUDEN; AVX; MURATA	0.1UF	CAPACITOR; SMT (0603); CERAMIC CHIP; 0.1UF; 100V; TOL=10%; TG=-55 DEGC TO +125 DEGC; TC=X7R
3	C3, C4		2	GRM21BR71H105K A12; CL21B105KBFNNN; C2012X7R1H105K0 85AC; UMK212B7105KG	MURATA; SAMSUNG ELECTRONICS; TDK	1UF	CAPACITOR; SMT (0805); CERAMIC CHIP; 1UF; 50V; TOL=10%; TG=-55 DEGC TO +125 DEGC; TC=X7R
4	DEFA, DEFB, ENA, ENB		4	PEC03SAAN	SULLINS	PEC03SAAN	CONNECTOR; MALE; THROUGH HOLE; BREAKAWAY; STRAIGHT; 3PINS
5	J1, J2		2	5-146128-6	TE CONNECTIVITY	5-146128-6	CONNECTOR; MALE; SMT; BREAKAWAY; STRAIGHT; 8PINS
6	R1-R12		12	CRCW040220R0FK	VISHAY DALE	20	RESISTOR; 0402; 20 OHM; 1%; 100PPM; 0.063W; THICK FILM
7	SPACER1- SPACER4		4	9032	KEYSTONE	9032	MACHINE FABRICATED; ROUND-THRU HOLE SPACER; NO THREAD; M3.5; 5/8IN; NYLON
8	SU1-SU4		4	S1100-B; SX1100-B; STC02SYAN	KYCON; KYCON; SULLINS ELECTRONICS CORP.	SX1100-B	TEST POINT; JUMPER; STR; TOTAL LENGTH=0.24IN; BLACK; INSULATION=PBT; PHOSPHOR BRONZE CONTACT=GOLD PLATED
9	TP1_GND A, TP1_GND B, TP2_GND A, TP2_GND B		4	5011	KEYSTONE	N/A	TEST POINT; PIN DIA=0.125IN; TOTAL LENGTH=0.445IN; BOARD HOLE=0.063IN; BLACK; PHOSPHOR BRONZE WIRE SILVER PLATE FINISH;
10	U1		1	MAX2256X	MAXIM	MAX2256X	EVKIT PART - IC; MAX2256X; OPTION FOR IMPROVED HV ISOLATION; CLEARANCE/CREEPAGE OF 5.5MM; PACKAGE OUTLINE DRAWING: 21- 0056; LAND PATTERN DRAWING: 90- 0094; PACKAGE CODE: A20MS+7; SSOP20
11	VDDA, VDDDB		2	5010	KEYSTONE	N/A	TEST POINT; PIN DIA=0.125IN; TOTAL LENGTH=0.445IN; BOARD HOLE=0.063IN; RED; PHOSPHOR BRONZE WIRE SIL;
12	PCB		1	MAX2256XA	MAXIM	PCB	PCB:MAX2256XA
13	RA1-RA6, RB1-RB6	DNP	0	N/A	N/A	OPEN	PACKAGE OUTLINE 0402 RESISTOR
14	CA1-CA6, CB1-CB6	DNP	0	N/A	N/A	OPEN	PACKAGE OUTLINE 0402 NON-POLAR CAPACITOR

MAX22563–MAX22566 EV Kit Schematic

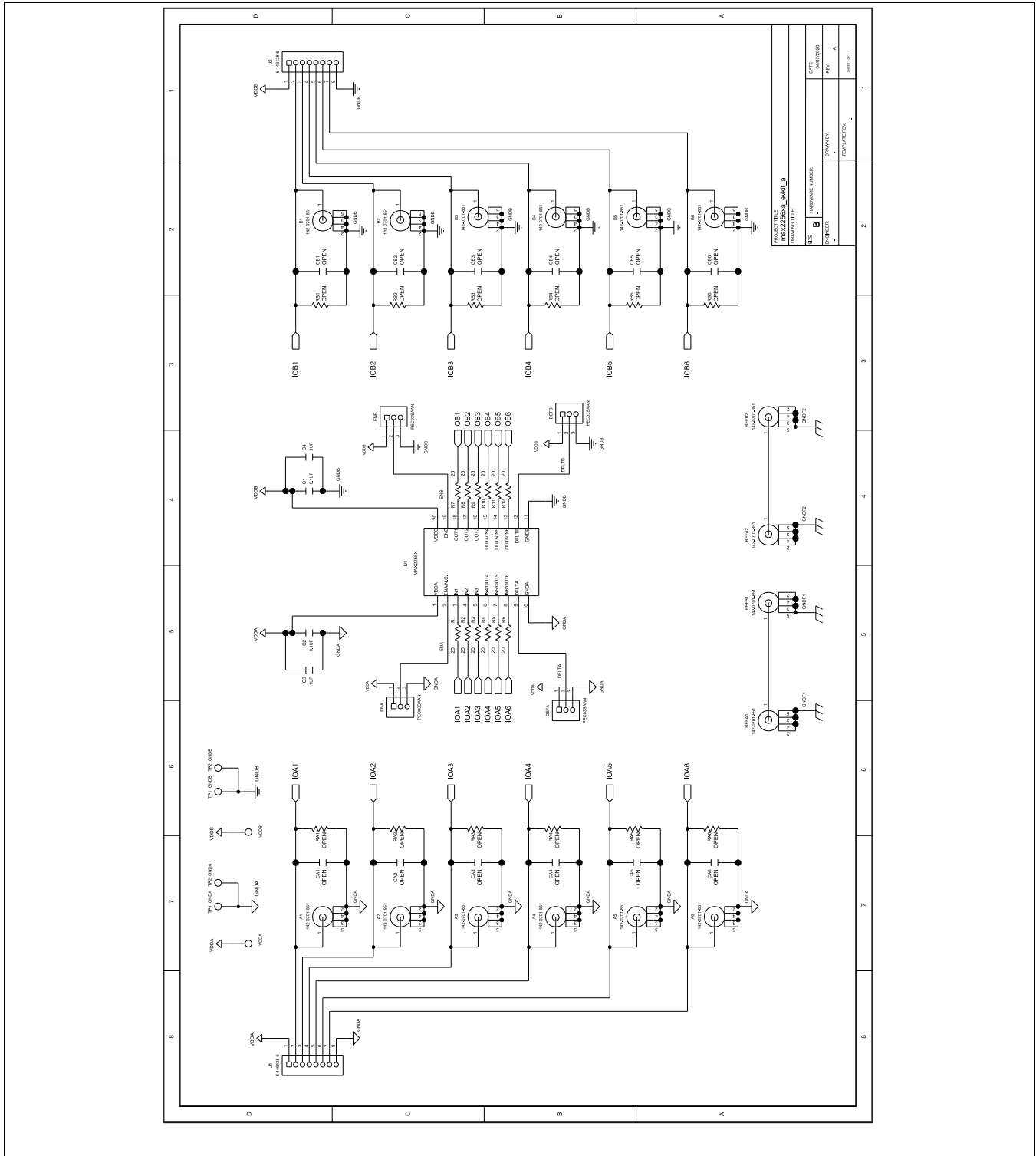

MAX22563–MAX22566 EV Kit PCB Layout

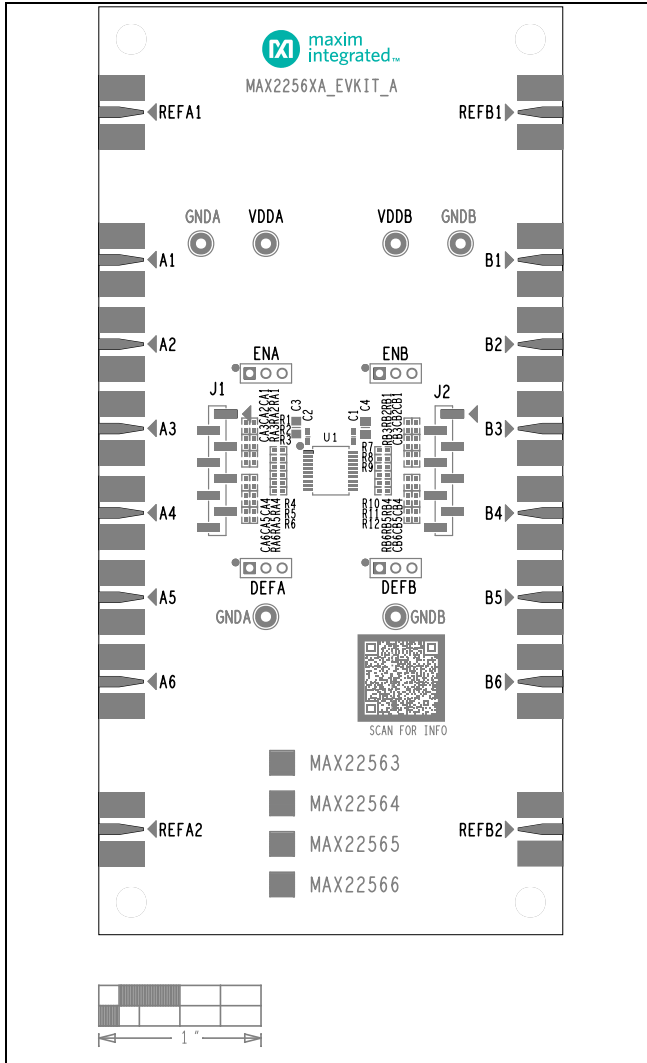

MAX22563–MAX22566 EV Kit PCB Layout—Top Silkscreen

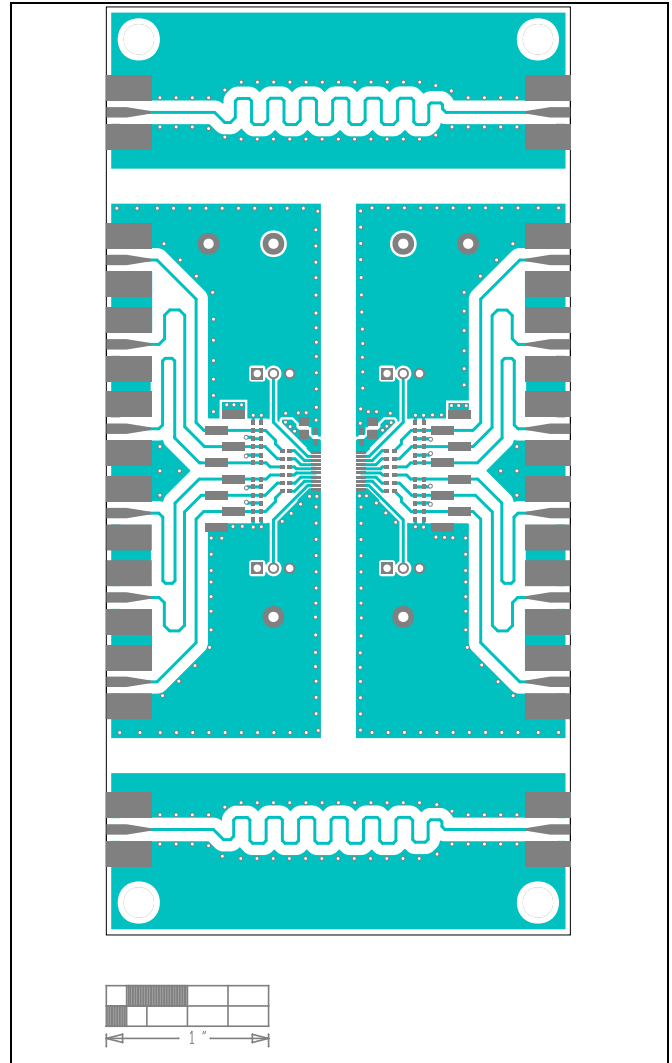

MAX22563–MAX22566 EV Kit PCB Layout—Top Layer

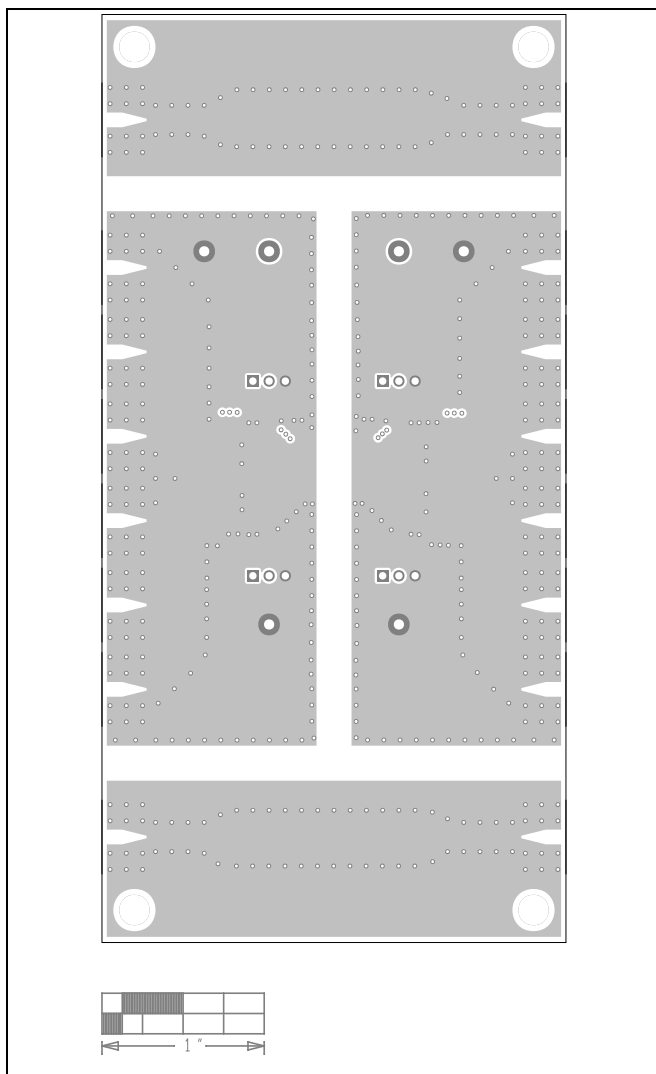

MAX22563–MAX22566 EV Kit PCB Layout—Layer 2 GND

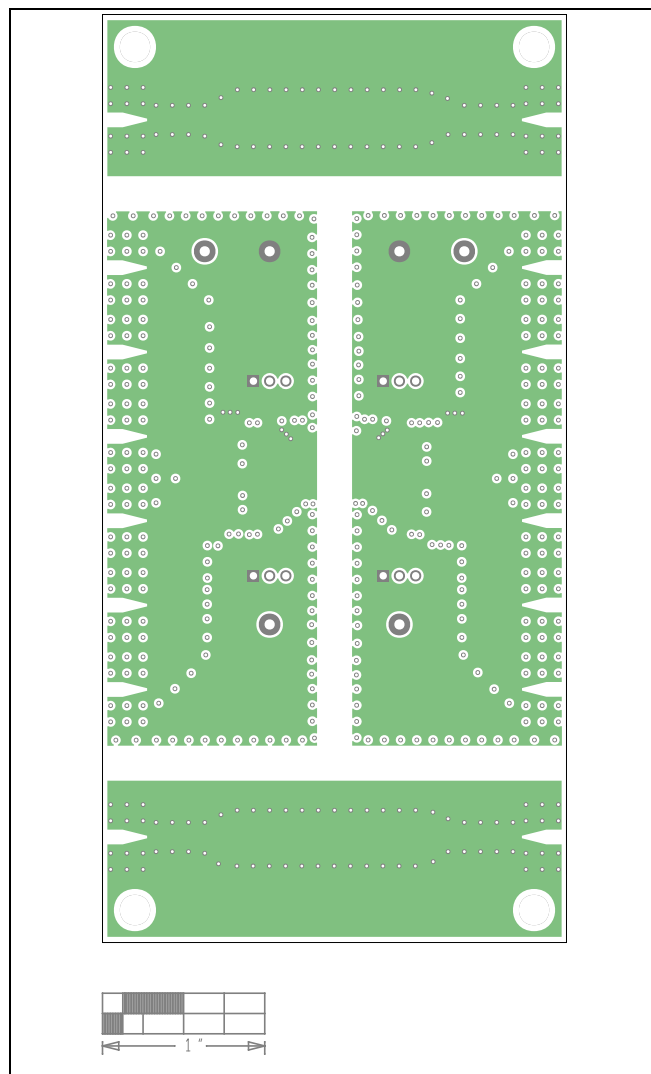

MAX22563–MAX22566 EV Kit PCB Layout—Layer 3 PWR

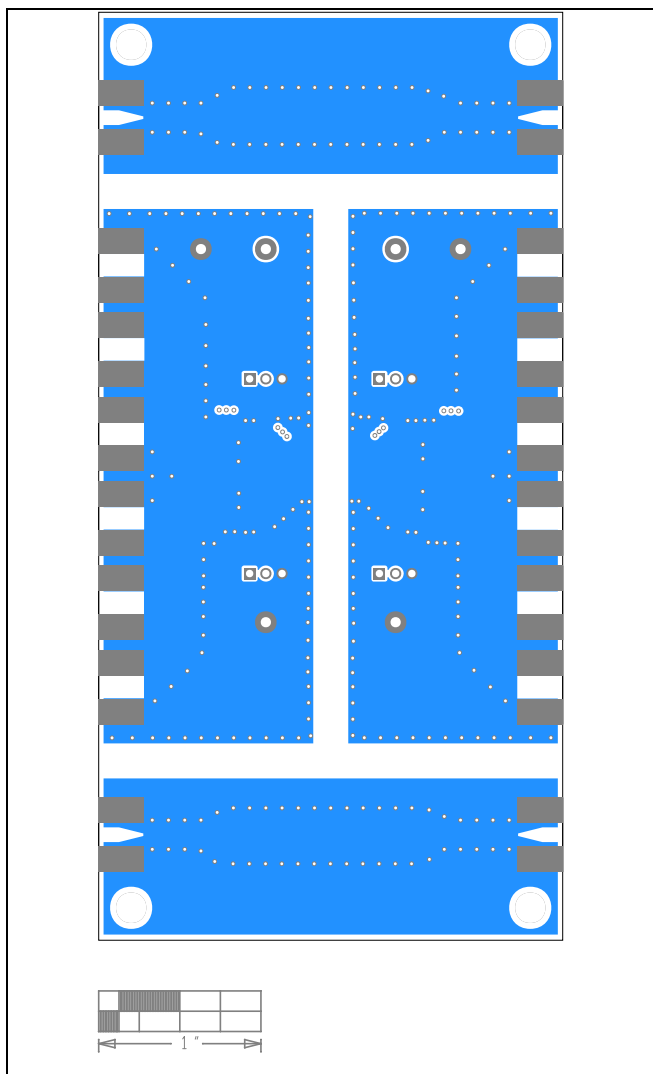

MAX22563–MAX22566 EV Kit PCB Layout—Bottom Layer

MAX22563–MAX22566

Evaluates: MAX22563–MAX22566

Evaluation Kits

Revision History

REVISION NUMBER	REVISION DATE	DESCRIPTION	PAGES CHANGED
0	8/21	Release for Market Intro	—

For pricing, delivery, and ordering information, please visit Maxim Integrated's online storefront at <https://www.maximintegrated.com/en/storefront/storefront.html>.

Maxim Integrated cannot assume responsibility for use of any circuitry other than circuitry entirely embodied in a Maxim Integrated product. No circuit patent licenses are implied. Maxim Integrated reserves the right to change the circuitry and specifications without notice at any time. The parametric values (min and max limits) shown in the Electrical Characteristics table are guaranteed. Other parametric values quoted in this data sheet are provided for guidance.

X-ON Electronics

Largest Supplier of Electrical and Electronic Components

Click to view similar products for [Interface Development Tools](#) category:

Click to view products by [Maxim](#) manufacturer:

Other Similar products are found below :

[ADP5585CP-EVALZ](#) [CHA2066-99F](#) [AS8650-DB](#) [MLX80104 TESTINTERFACE](#) [416100120-3](#) [XR18910ILEVB](#) [XR21B1421IL28-0A-EVB](#) [TW-DONGLE-USB](#) [EVAL-ADM2491EEBZ](#) [MAXREFDES23DB#](#) [MAX13235EEVKIT](#) [DFR0257](#) [XR22404CG28EVB](#) [ZLR964122L](#) [ZLR88822L](#) [EVK-U23-01S](#) [EVK-W262U-00](#) [DC327A](#) [PIM511](#) [PIM536](#) [PIM517](#) [DEV-17512](#) [STR-FUSB3307MPX-PPS-GEVK](#) [MAXREFDES177#](#) [EVAL-ADM2567EEBZ](#) [ZSSC3240KIT](#) [MAX9121EVKIT](#) [PIM532](#) [ZSC31010KITV2P1](#) [UMFT4233HPEV](#) [LVDS-18B-EVK](#) [XR20M1170G16-0A-EB](#) [XR20M1170G16-0B-EB](#) [XR20M1170G24-0B-EB](#) [XR20M1172G28-0A-EB](#) [XR20M1172G28-0B-EB](#) [SI871XSOIC8-KIT](#) [1764](#) [1833](#) [1862](#) [EVB-USB82514](#) [ATA6628-EK](#) [ATA6631-EK](#) [EVAL-CN0313-SDPZ](#) [2264](#) [MCP23X17EV](#) [PS081-EVA-HR MODULE](#) [237](#) [SMA2RJ45EVK/NOPB](#) [FR12-0002](#)