

General Description

The MAX22707 evaluation kit (EV kit) provides a proven design to evaluate MAX22707 low power, precision zero-crossing detector.

The MAX22707 EV kit features an isolated power and signal interface to configure and evaluate different modes. The EV kit features two independent MAX22707 sections that can be evaluated in lowpass filter (LPF) configuration mode and bandpass filter (BPF) configuration mode.

The EV kit comes with two MAX22707AUB+ (10 μ MAX, 3.05mm x 5.05mm footprint) devices installed.

Features

- Robust Operation with Connector Interface to 110VAC and 220VAC Inputs
- Easy Evaluation of the MAX22707 in Different Configuration Modes
- EV Kit is USB Powered with Optional Power from Terminal Block
- Fully Assembled and Tested
- Proven PCB Layout
- RoHS Compliant

[Ordering Information](#) appears at end of data sheet.

Quick Start

Required Equipment

- MAX22707 EV kit
- Micro-USB cable (to PC or 5V Adaptor) or +5V bench supply
- Oscilloscope
- AC adaptor wire to AC Interface (110VAC or 220VAC) or AC supply

Warning: High voltage interface input. The user should be aware of the hazards associated with higher voltages, which could cause any of the associated test points or circuit traces to have a hazardous potential.

For safety before handling, make sure to discharge high impedance nodes to earth ground after evaluation with high voltage interface.

Procedure

The EV kit is fully assembled and tested.

The default jumper settings in lowpass configuration section configure the MAX22707 (U7) to operate in Type 3 mode (full wave rectified input).

The default jumper settings in bandpass configuration section configure the MAX22707 (U8) to operate in Type 1 single-ended mode.

Follow the steps to verify board operation:

See [Table 1](#) Jumper Positions and Configurations

See [Table 2](#) Header Description

Refer to the [MAX22707_DS](#) on different input types (Type 1-4)

1. Verify that all jumpers are in default positions ([Table 1](#)).
2. Power the EV kit with a micro-USB cable to a PC or 5V adaptor at the J9 micro-USB connector. Alternatively, the terminal block J6 can be used to power the EV kit from a benchtop power supply when J9 is not used.
3. Connect an oscilloscope probe at ZCO_A_OUTPUT J12(2) and ZCO_B_OUTPUT J13(2).
4. For evaluating the LPF mode, a shunt is installed across J1 (1-2). Verify the VCCA LED is green, indicating there is power available to the LPF section. To evaluate the BPF mode, skip step 10 of the procedure.
5. With the AC supply turned off, connect the line terminal to LINE connector J20. Connect the neutral terminal to NEUTRAL connector J22.

MAX22707 Evaluation Kit

Evaluates: MAX22707

- Turn on the AC supply and observe for digital output transitions at ZCO_A_OUTPUT on the oscilloscope.
- Disable the AC supply and power supply in that order after evaluation.
- To evaluate other input types for LPF mode, see [Table 3](#) for all modifications and configuration settings and follow steps 2-7.
- Alternatively, to observe for AC input (attenuated low-voltage level) and ZCO output at the high voltage side, the oscilloscope power supply must be floating, and the oscilloscope probes must be connected from the test points provided at INP_LP, INM_LP, and J27 with respect to the high voltage side ground GNDF.
- For evaluating the BPF mode, install a shunt across J1(2-3). Verify VCCB LED is green, indicating power is available to the BPF section.
- With the AC supply turned off, connect the line terminal to LINE+ connector J15. Connect the neutral terminal to LINE- connector J16.
- Turn on the AC supply and observe for digital output transitions at ZCO_B_OUTPUT on the oscilloscope.
- Disable the AC supply and power supply in that order after evaluation.
- To evaluate other input types for BPF mode, see [Table 4](#) for all modifications and configuration settings and follow steps 11-13.
- Alternatively, to observe for AC input (attenuated low-voltage level) and ZCO output at the high voltage side, the oscilloscope power supply must be floating, and the scope probes must be connected from the test points provided at INP_BP, INM_BP, and J28 with respect to high voltage side ground GNDF.

MAX22707 EV Kit Photo

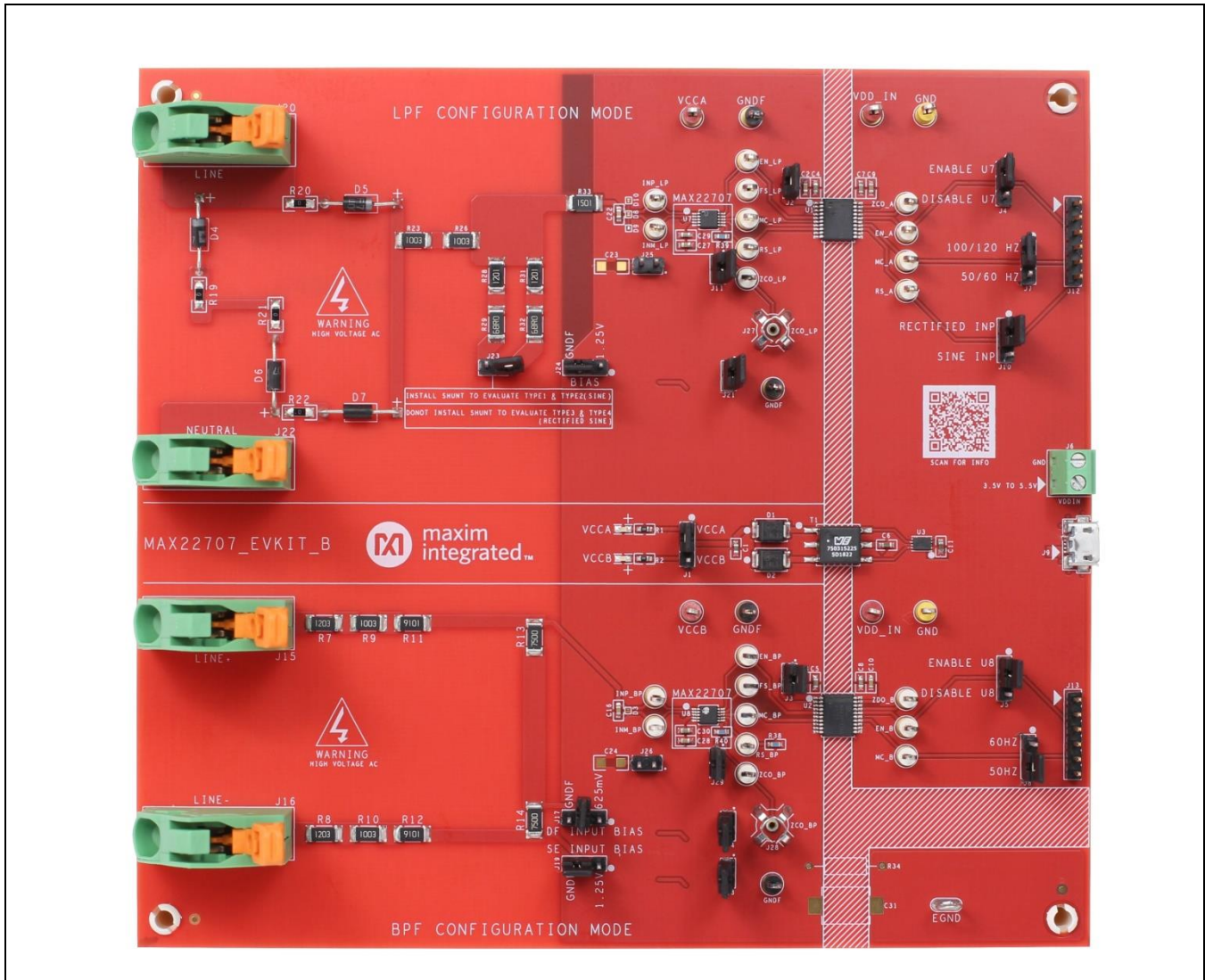

MAX22707 EV Kit Block Diagram

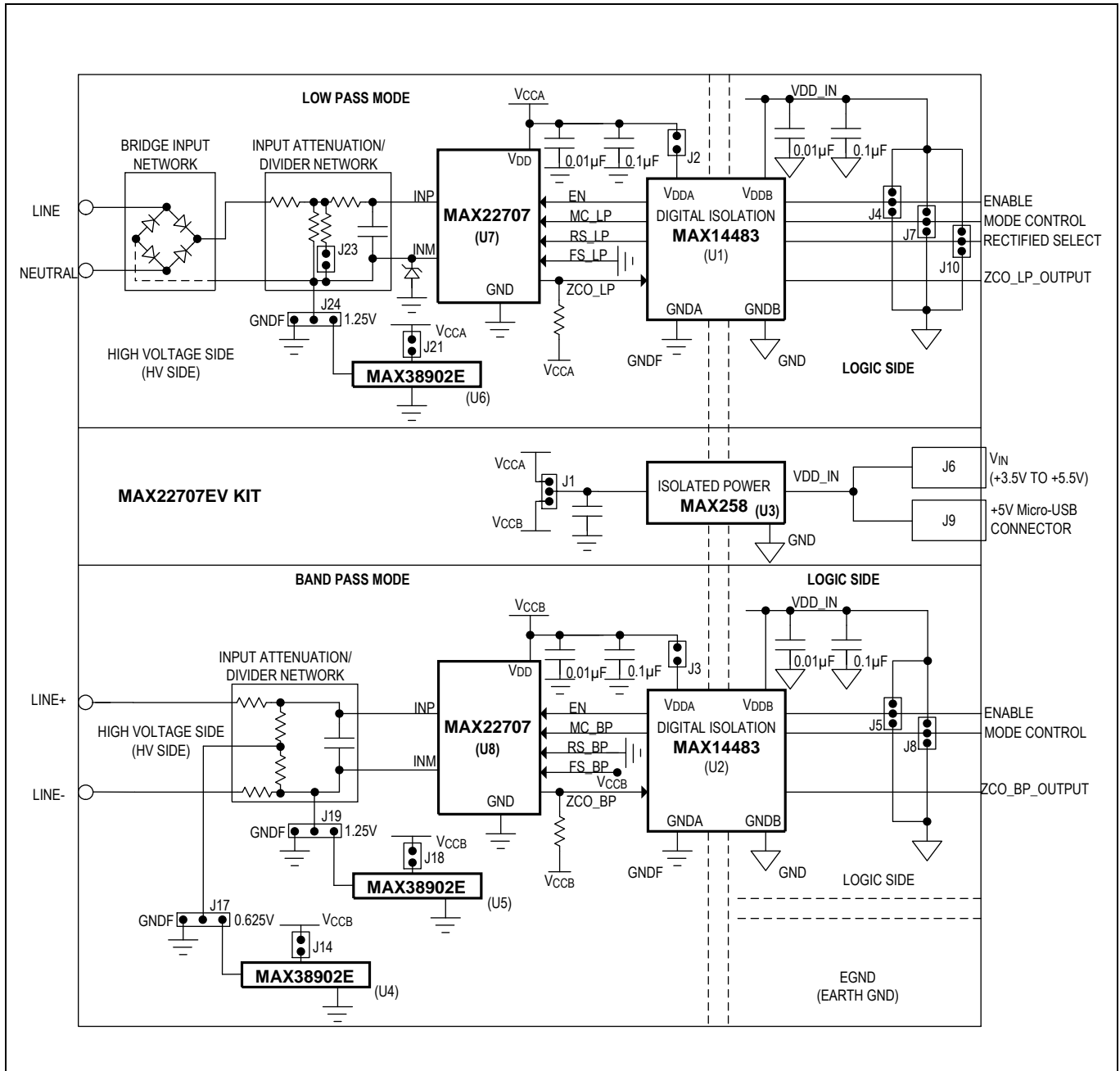

Table 1. MAX22707 EV Kit Shunt Positions and Settings

JUMPER	SHUNT POSITION	FEATURES
ISOLATED POWER SECTION		
J1	1-2*	Connects the isolated power to V_{CCA} (LPF section)
	2-3	Connects the isolated power to V_{CCB} (BPF section)
LPF CONFIGURATION SECTION		
J2 (HV SIDE)	1-2*	Connects V_{CCA} to supply input of the MAX14483 (U1)
	Not Installed	The V_{CCA} supply input of the MAX14483 (U1) is not connected
J11 (HV SIDE)	1-2*	Connects V_{CCA} to pullup resistor at the zero-crossing output (ZCO)
	Not Installed	Disconnects the V_{CCA} to pullup resistor at ZCO
J21 (HV SIDE)	1-2*	Connects V_{CCA} to supply input of the MAX38902 (U6)
	Not Installed	The V_{CCA} supply input of the MAX38902 (U6) is not connected
J23 (HV SIDE)	1-2	Evaluates Type 1 and Type 2 (sine) inputs
	Not Installed*	Evaluates Type 3 and Type 4 (rectified sine) inputs
J24 (HV SIDE)	1-2	1.25V bias at INM for Type 2 (sine) input
	2-3*	GND bias at INM for Type 1, 3, and 4 inputs
J25 (HV SIDE)	1-2	Connects C23 to DCAP pin. Use when other than 220nF (C25) C_{DCAP} is required
	Not Installed*	220nF (C25) C_{DCAP} is connected to the DCAP pin of the MAX22707
J4 (LOGIC SIDE)	1-2*	Enables the MAX22707 (U7) in active mode
	2-3	Disables the MAX22707
J7 (LOGIC SIDE)	1-2*	Mode control input select 100/120Hz operation
	2-3	Mode control input select 50/60Hz operation
J10 (LOGIC SIDE)	1-2*	Rectified input-select option (half wave or full wave input)
	2-3	Sine input-select option
BPF CONFIGURATION SECTION		
J3 (HV SIDE)	1-2*	Connects V_{CCB} to supply input of the MAX14483 (U2)
	Not Installed	The V_{CCB} supply input of the MAX14483 (U2) is not connected
J29 (HV SIDE)	1-2*	Connects V_{CCB} to pullup resistor at the zero-crossing output (ZCO)
	Not Installed	Disconnects the V_{CCB} to pullup resistor at ZCO
J14 (HV SIDE)	1-2*	Connects V_{CCB} to supply input of the MAX38902 (U4)
	Not Installed	The V_{CCB} supply input of the MAX38902 (U4) is not connected
J18 (HV SIDE)	1-2*	Connects V_{CCA} to supply input of the MAX38902 (U5)
	Not Installed	The V_{CCB} supply input of the MAX38902 (U5) is not connected
J17 (HV SIDE)	1-2	0.625V bias for Type 2 (sine) differential (DF) input
	2-3	GND bias Type 1 (sine) differential (DF) input
J19 (HV SIDE)	1-2	1.25V bias for Type 2 (sine) single-ended (SE) input
	2-3*	GND bias Type 1 (sine) single-ended (SE) input
J5 (LOGIC SIDE)	1-2*	Enables the MAX22707 (U8) in active mode
	2-3	Disables the MAX22707
J8 (LOGIC SIDE)	1-2*	Mode control input select 60Hz operation
	2-3	Mode control input select 50Hz operation

* Default position

Table 2. MAX22707 EV Kit Header Description

HEADER	POSITION	NAME	FEATURES
J12	1	PWR_OK_A	Output from Digital Isolator. Logic-level high, indicating power good signal from the high voltage side. When the power is not present at V_{CCA} , the signal is low.
	2	ZCO_A_OUT	Isolated zero-crossing output from the MAX22707 (U7)
	3	EN_A	Enable input. Connected to J4. Remove J4 shunt when driving enable from an external source.
	4	—	Unused
	5	MC_A	Enable input. Connected to J7. Remove J7 shunt when driving mode control signal from an external source.
	6	RS_A	Enable input. Connected to J10. Remove J10 shunt when driving rectified select signal from an external source.
J13	1	PWR_OK_B	Output from digital isolator. Logic-level high, indicating power good signal from the high voltage side. When the power is not present at V_{CCB} , the signal is low.
	2	ZCO_B_OUT	Isolated zero-crossing output from the MAX22707 (U8)
	3	EN_B	Enable input. Connected to J5. Remove J5 shunt when driving enable from an external source.
	4	—	Unused
	5	MC_B	Enable input. Connected to J8. Remove J8 shunt when driving mode control signal from an external source.
	6	—	Unused

Detailed Description of Hardware

The MAX22707 EV kit provides an easy to use and flexible solution for evaluating the MAX22707, a low power precision zero-crossing detector. The EV kit comes with two MAX22707 configured independently in lowpass mode and bandpass mode, high voltage AC input interface, and input attenuation network to evaluate the device and the system.

The EV kit comes with both the LPF and BPF sections on the high voltage isolated side (HV side) are configured in default modes (see [Table 1](#)). The jumper shunts provided on the logic side are used to select different configurations within each section. Alternatively, the headers (J12) and (J13) on the logic side can be used when externally driving the logic signals to configure the MAX22707 devices (U7) and (U8).

The default configuration for the LPF section is to accept Type 3 full wave rectified input (U7).

The default configuration for the BPF section is to accept Type 1 single-ended sine wave input (U8).

Device Powering Options

The MAX22707 EV kit is entirely powered from either the micro-USB connector (J9) or the terminal block (J6). Alternatively, the EV kit can be powered using +3.5V to +5.5V supply applied to terminal block J6. The power supplied generates isolated power on the isolated high voltage side (HV side) section. The MAX258 transformer driver and transformer T1 convert logic side power to supply either V_{CCA} (LPF section) or V_{CCB} (BPF section).

At a given time, only one of the sections (LPF or BPF) can be evaluated. To evaluate the LPF section, a shunt is installed at jumper J1 across 1-2, and to evaluate the BPF section, a shunt is installed at jumper J1 across 2-3.

Evaluating Different Input Types

The high voltage input resistor network has series resistance $>100k\Omega$ to the AC interface connectors. The resistor divider converts the line voltage applied across connectors LINE (J20) and NEUTRAL (J22) to low voltage that MAX22707 (U7) can handle. For the Type 1 and Type 2 single ended inputs (SE), a shunt across jumper J23 is installed for converting a typical 220VAC signal to $2V_{pk-pk}$. When evaluating the Type1 and Type 2 inputs, the input diode bridge must be modified as per [Table 3](#). To evaluate in Type 2 input mode, install a shunt across jumper J24 (1-2) to bias the INM input at 1.25V. To evaluate in Type 1 input mode, install a shunt across jumper J24 (2-3) to bias the INM input at ground GNDF.

To evaluate the Type 3 and Type 4 rectified inputs, jumper J23 is removed to convert a typical 220VAC signal to $2V_{pk-pk}$. When evaluating the Type 4 input, the input diode bridge must be modified as per [Table 3](#).

[Table 3](#) shows jumper configurations required to configure the MAX22707 (U7) in different LPF modes. For more information about the input types, refer to the [MAX22707 data sheet](#).

Table 3. LPF Configuration Modes

MODE	SIGNAL TYPE	JUMPER POSITION					HV INPUT DIODE BRIDGE COMBINATION
		DIGITAL INPUT			HV INPUT NETWORK	INM: INPUT BIAS SELECTION	
		MC	RS	FS			
Type 1	Bipolar Sine, Single Ended (SE)	J7 (2-3) LOW	J10 (2-3) LOW	N/A LOW	J23 (1-2)	J24 (2-3)	Remove: R19, R22, D4, D7 D5, D6: Replace with wire short
Type 2	Unipolar Sine, Single Ended (SE)	J7 (2-3) LOW	J10 (2-3) LOW	N/A LOW	J23 (1-2)	J24 (1-2)	Remove: R19, R22, D4, D7 D5, D6: Replace with wire short
Type 3	Full wave Rectified (SE)	J7 (1-2) HIGH	J10 (1-2) HIGH	N/A LOW	J23- Not Installed	J24 (2-3)	Default combination
Type 4	Half wave Rectified (SE)	J7 (2-3) LOW	J10 (1-2) HIGH	N/A LOW	J23- Not Installed	J24 (2-3)	Remove: R19, R22

The high voltage input resistor network has series resistance $>200k\Omega$ to the AC interface connectors. The resistor divider converts the line voltage applied across connectors LINE+ (J15) and LINE- (J16) to low voltage that MAX22707 (U8) can handle. The input network converts a typical 220VAC signal to $2V_{pk-pk}$.

To evaluate Type 1 or Type 2 SE Inputs, a shunt is applied at jumper J19. To evaluate Type 1 single-ended input, a shunt is applied across the jumper J19 (2-3) that provides a 0V (GNDF) bias to the input network. To evaluate Type 2 SE input, a shunt is applied across jumper J19 (1-2) that provides 1.25V bias to the input network. To evaluate SE inputs across LINE+ and LINE- in BPF mode, a shunt across jumper J17 is not installed.

A shunt across Jumper J17 is used to evaluate Type 1 or Type 2 differential inputs (DF). A shunt across jumper J17 (2-3) provides a 0V bias when Type 1 input is used. A 0.625V bias is provided when a shunt is applied across J17(1-2) to evaluate Type 2 DF input. To evaluate DF input across LINE+ and LINE- in BPF mode, a shunt across jumper J19 is not installed.

[Table 4](#) shows jumper configurations required to configure the MAX22707 (U8) in different BPF modes.

Table 4. BPF Configuration Modes

MODE	SIGNAL TYPE	JUMPER POSITION				
		DIGITAL INPUT			SINGLE ENDED INPUT BIAS SELECTION	DIFFERENTIAL INPUT BIAS SELECTION
		MC	RS	FS		
Type1	Bipolar Sine, Single Ended (SE)	J8 (1-2) / (2-3) HIGH / LOW	N/A LOW	N/A HIGH	J19 (2-3)	J17 Not Installed
Type1	Bipolar Sine, Differential Input (DF)	J8 (1-2) / (2-3) HIGH / LOW	N/A LOW	N/A HIGH	J19 Not Installed	J17 (2-3)
Type 2	Unipolar Sine, Single Ended (SE)	J8 (1-2) / (2-3) HIGH / LOW	N/A LOW	N/A HIGH	J19 (1-2)	J17 Not Installed
Type 2	Unipolar Sine, Differential Input (DF)	J8 (1-2) / (2-3) HIGH / LOW	N/A LOW	N/A HIGH	J19 Not Installed	J17 (1-2)

Input Attenuation Network

The input series resistance seen across the high voltage AC connectors must be $>100\text{k}\Omega$. The external high voltage input needs to be divided down to acceptable signal levels of the MAX22707. High wattage resistors must be chosen to handle the power dissipation during attenuation of the input signal. The input series resistance value at each high voltage AC connector must be $\leq 1\text{M}\Omega$.

The user should be aware of the hazards associated with higher voltages, which could cause any of the associated test points or circuit traces to have a hazardous potential.

Input Network Bias

The MAX38902 low noise LDO generates the bias for the input network. In LPF mode, U6 is configured to provide 1.25V of bias to the INM input of the MAX22707 (U7) when a jumper shunt J24 is installed across (1-2).

The device U4 (MAX38902) provides 0.625V bias to the BPF input circuitry for differential inputs when a shunt is installed across J17(1-2), and U5 provides 1.25V for single ended inputs when a shunt is applied across J19 (1-2).

IEC 61000-4 Transient Immunity Compliance

The typical application for MAX22707 requires to pass basic transient immunity standards as defined by IEC 61000-4-x, covering -2 for Electrostatic (ESD), -4 for Electrical Fast Transient/Burst (EFT), and -5 for Surge immunity. The MAX22707 EV kit includes circuitry to support testing to these standards to support $\pm 6\text{kV}$ line-to-EGND (Earth GND) and line-to-line surge, $\pm 8\text{kV}$ contact ESD, and $\pm 15\text{kV}$ air gap ESD. TVS diode (D9) provides protection from ESD voltage applied at INM input. The EV kit includes circuitry to support up to $\pm 3\text{kV}$ EFT with default components included.

See [Figure 1](#) for connections and configuration used in high voltage immunity testing. It shows the disconnected jumper sections and connections in red, indicating the supporting devices are disconnected from the active circuitry and are not part of the high voltage immunity testing. Only the input resistive network and MAX22707 are considered for the immunity compliance.

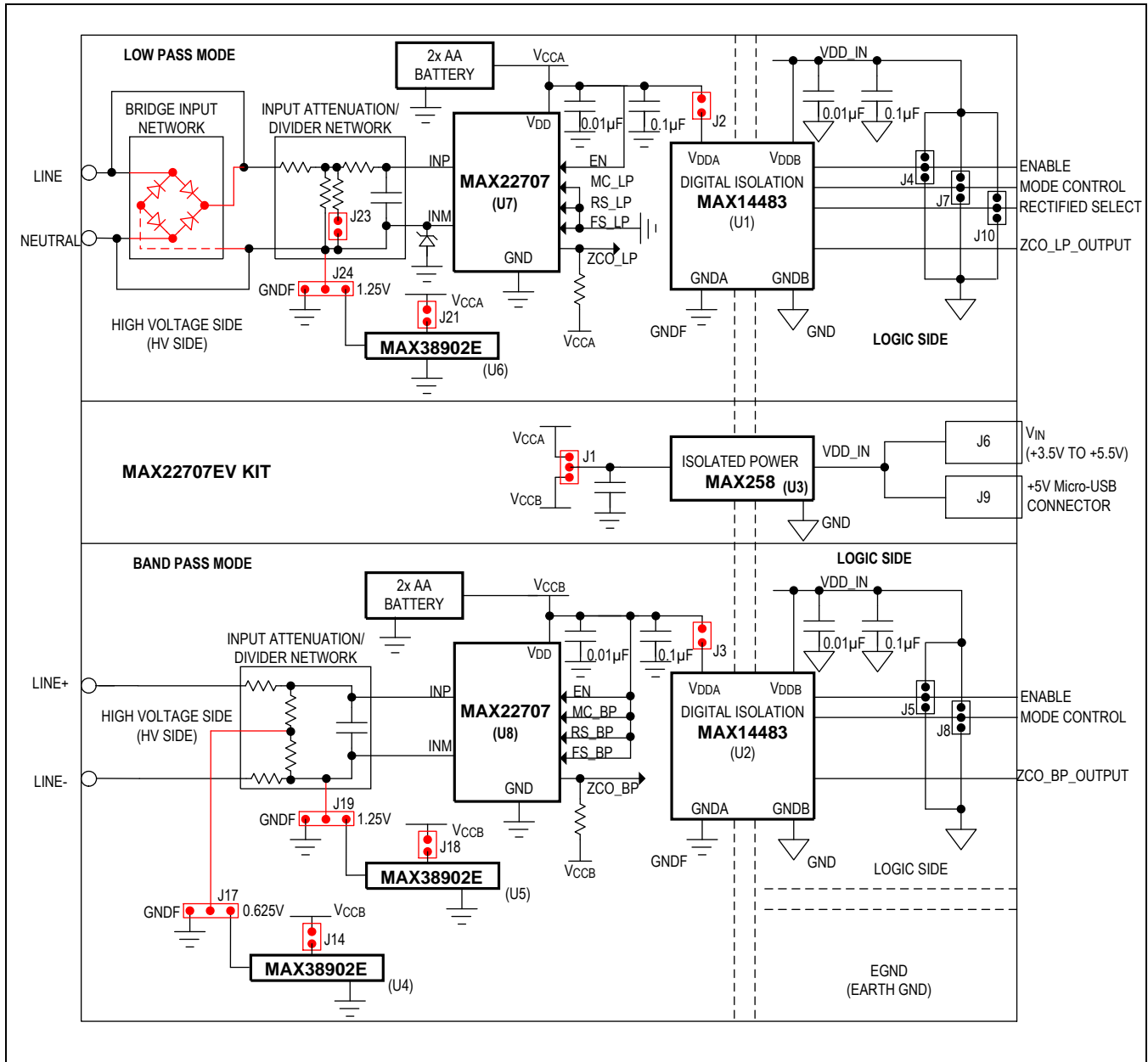

Figure 1. MAX22707EV Kit High Voltage Test Configuration

Ordering Information

PART	TYPE
MAX22707EVKIT#	EV Kit

#Denotes RoHS-compliance.

MAX22707 EV Kit Bill of Materials

PART	QTY	DESCRIPTION
C1, C11	2	CAP; SMT (0603); 1UF; 10%; 25V; X7R; CERAMIC
C2, C3, C9, C10, C27, C28	6	CAP; SMT (0603); 0.1UF; 10%; 16V; X7R; CERAMIC
C4, C5, C7, C8, C13, C17, C20, C29, C30	9	CAP; SMT (0603); 0.01UF; 5%; 25V; C0G; CERAMIC
C6, C12, C14, C15, C18, C19, C21	7	CAP; SMT (0603); 10UF; 20%; 16V; X5R; CERAMIC
C16, C22	2	CAP; SMT (0603); 0.022UF; 10%; 50V; X7R; CERAMIC
C25, C26	2	CAP; SMT (0603); 0.22UF; 10%; 25V; X7R; CERAMIC
D1, D2	2	DIODE; SCH; SMB (DO-214AA); PIV=30V; IF=2A
D4-D7	4	DIODE, RECTIFIER, DO-41, PIV=1000V, If(ave)=1A, Vf=1.1V@If=1A
EGND	1	EVK KIT PARTS; MAXIM PAD; WIRE; NATURAL; SOLID; WEICO WIRE; SOFT DRAWN BUS TYPE-S; 20AWG
EN_A_OUT, EN_BP, EN_B_OUT, EN_LP, FS_BP, FS_LP, INM_BP, INM_LP, INP_BP, INP_LP, MC_A_OUT, MC_BP, MC_B_OUT, MC_LP, RS_A_OUT, RS_BP, RS_LP, ZCO_A_OUT, ZCO_BP, ZCO_LP, ZDO_B_OUT	21	TEST POINT; PIN DIA=0.125IN; TOTAL LENGTH=0.445IN; BOARD HOLE=0.063IN; WHITE; PHOSPHOR BRONZE WIRE SILVER PLATE FINISH;
J1, J4, J5, J7, J8, J10, J17, J19, J24	9	CONNECTOR; MALE; THROUGH HOLE; BREAKAWAY; STRAIGHT THROUGH; 3PINS; -65 DEGC TO +125 DEGC
J2, J3, J11, J14, J18, J21, J23, J25, J26, J29	10	CONNECTOR; MALE; THROUGH HOLE; BREAKAWAY; STRAIGHT THROUGH; 2PINS; -65 DEGC TO +125 DEGC
J6	1	CONNECTOR; FEMALE; THROUGH HOLE; GREEN TERMINAL BLOCK; RIGHT ANGLE; 2PINS
J9	1	CONNECTOR; FEMALE; SMT; MICRO USB B TYPE RECEPTACLE; RIGHT ANGLE; 5PINS
J12, J13	2	CONNECTOR; MALE; THROUGH HOLE; BREAKAWAY; STRAIGHT; 6PINS; -65 DEGC TO +125 DEGC
J15, J16, J20, J22	4	CONNECTOR; FEMALE; THROUGH HOLE; TERMINAL BLOCK; RIGHT ANGLE; 1PIN
J27, J28	2	CONNECTOR; WIREMOUNT; 3 GHZ 20X LOW CAPACITANCE PROBE; STRAIGHT; 5PINS
MH1-MH4	4	MACHINE FABRICATED; ROUND-THRU HOLE SPACER; NO THREAD; M3.5; 5/8IN; NYLON
R1, R2	2	RES; SMT (0603); 3.3K; 1%; +/-100PPM/DEGC; 0.1000W
R3, R24, R36	3	RES; SMT (0603); 1K; 0.05%; +/-5PPM/DEGC; 0.1000W
R4, R16, R25	3	RES; SMT (0603); 300K; 0.10%; +/-25PPM/DEGC; 0.1000W
R5, R17, R27	3	RES; SMT (0603); 100K; 0.10%; +/-25PPM/DEGC; 0.0630W
R6, R18, R30	3	RES; SMT (0805); 0; JUMPER; JUMPER; 0.5000W
R7, R8	2	RES; SMT (2010); 120K; 1%; +/-100PPM/DEGC; 2W
R9, R10, R23, R26	4	RES; SMT (2010); 100K; 1%; +/-100PPM/DEGC; 2W
R11, R12	2	RES; SMT (2010); 9.1K; 1%; +/-100PPM/DEGC; 2W
R13, R14	2	RES; SMT (2010); 750; 1%; +/-100PPM/DEGC; 2W
R15	1	RES; SMT (0603); 11.5K; 1%; +/-100PPM/DEGC; 0.1000W
R19-R22	4	RES; SMT (1206); 0; JUMPER; JUMPER; 0.2500W
R28, R31	2	RES; SMT (2010); 1.2K; 1%; +/-100PPM/DEGC; 2W
R29, R32	2	RES; SMT (2010); 68; 1%; +/-100PPM/DEGC; 2W
R33	1	RES; SMT (2010); 1.5K; 1%; +/-100PPM/DEGC; 2W
R35, R37	2	RES; SMT (0603); 324K; 0.10%; +/-10PPM/DEGC; 0.0630W
R38-R40	3	RES; SMT (0603); 10K; 0.10%; +/-25PPM/DEGC; 0.1000W
SU1-SU17	17	CONNECTOR; FEMALE; MINI SHUNT; 0.100IN CC; OPEN TOP; JUMPER; STRAIGHT; 2PINS

PART	QTY	DESCRIPTION
T1	1	TRANSFORMER; SMT; 1:1.1; PUSH-PULL TRANSFORMER
TP1, TP4, VDD_IN, VDD_IN1	4	TEST POINT; PIN DIA=0.125IN; TOTAL LENGTH=0.445IN; BOARD HOLE=0.063IN; RED; PHOSPHOR BRONZE WIRE SIL;
TP2, TP3, TP7, TP8	4	TEST POINT; PIN DIA=0.125IN; TOTAL LENGTH=0.445IN; BOARD HOLE=0.063IN; BLACK; PHOSPHOR BRONZE WIRE SILVER PLATE FINISH;
TP5, TP6	2	TEST POINT; PIN DIA=0.125IN; TOTAL LENGTH=0.445IN; BOARD HOLE=0.063IN; YELLOW; PHOSPHOR BRONZE WIRE SILVER PLATE FINISH;
U1, U2	2	IC; DISO; 6-CHANNEL; LOW-POWER; 3.75KVRMS SPI DIGITAL ISOLATOR; SSOP20
U3	1	IC; DRV; 0.5A; PUSH-PULL TRANSFORMER DRIVER FOR ISOLATED POWER SUPPLY; TDFN8-EP 2X3
U4-U6	3	IC; REG; 14MICRO VRMS LOW NOISE 500 MILLIAMPERE LDO LINEAR REGULATOR; TDFN8-EP
U7, U8	2	EVKIT PART -IC; RX35; DET; LOW POWER PRECISION ZERO CROSSING DETECTOR; PACKAGE OUTLINE DRAWING: 21-0061; LAND PATTERN DRAWING: 90-0330; PACKAGE CODE: U10+6C; UMAX10
VCCA, VCCB	2	DIODE; LED; SMT CHIPLD; GREEN; SMT (0603); VF=3.3V; IF=0.02A
PCB	1	PCB:MAX22707
C31	0	CAP; SMT; 1000PF; 20%; 250V; E; CERAMIC
D3, D8-D10	0	DIODE; TVS; SMT (01005); VRM=3.3V; IPP=4.5A
R34	0	RES; THROUGH HOLE-AXIAL LEAD; 10M; 1%; +/-100PPM/DEGC; 0.25W
C23, C24	0	PACKAGE OUTLINE 1206 NON-POLAR CAPACITOR

MAX22707 EV Kit Schematic

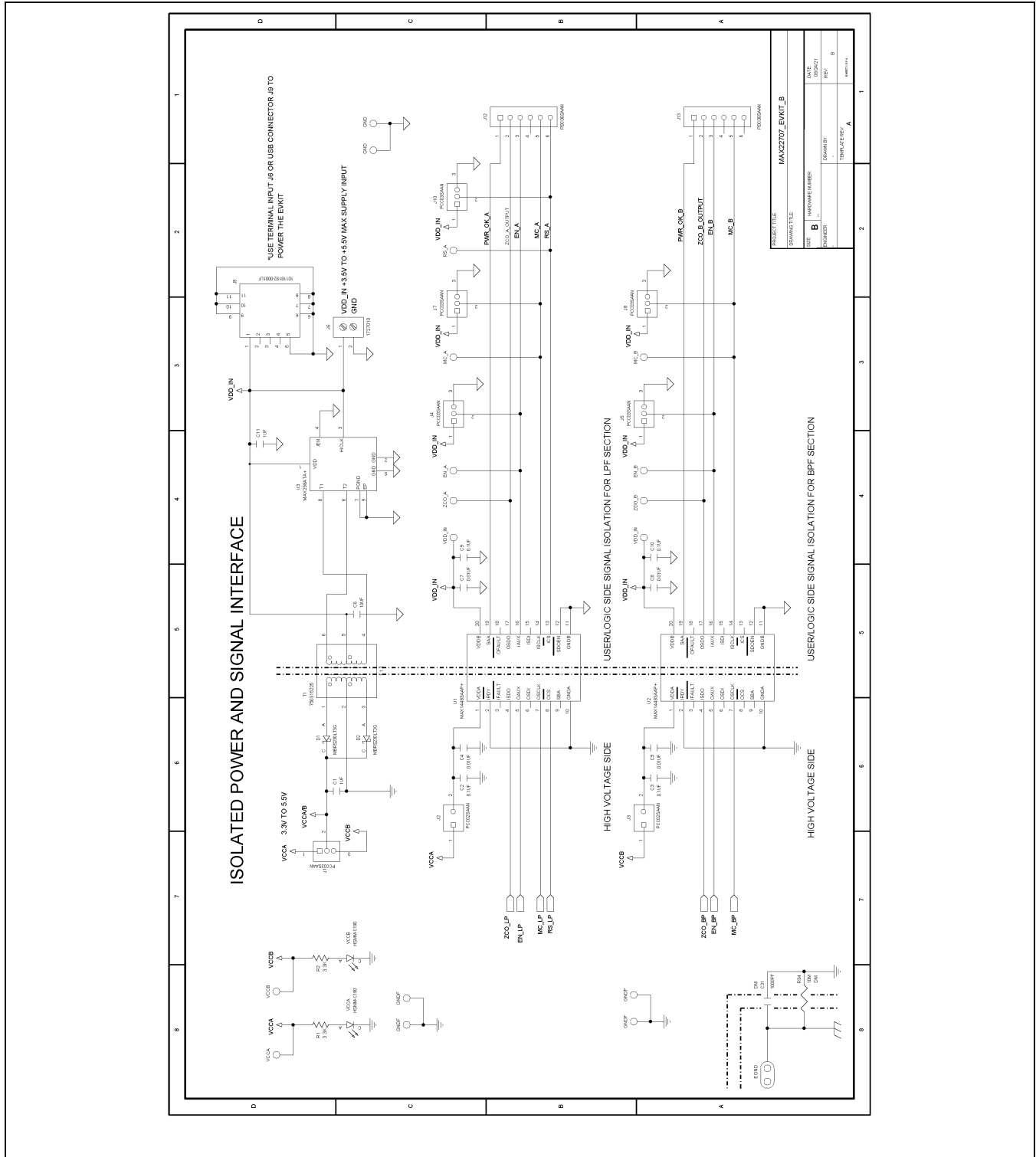

MAX22707 EV Kit Schematic (continued)

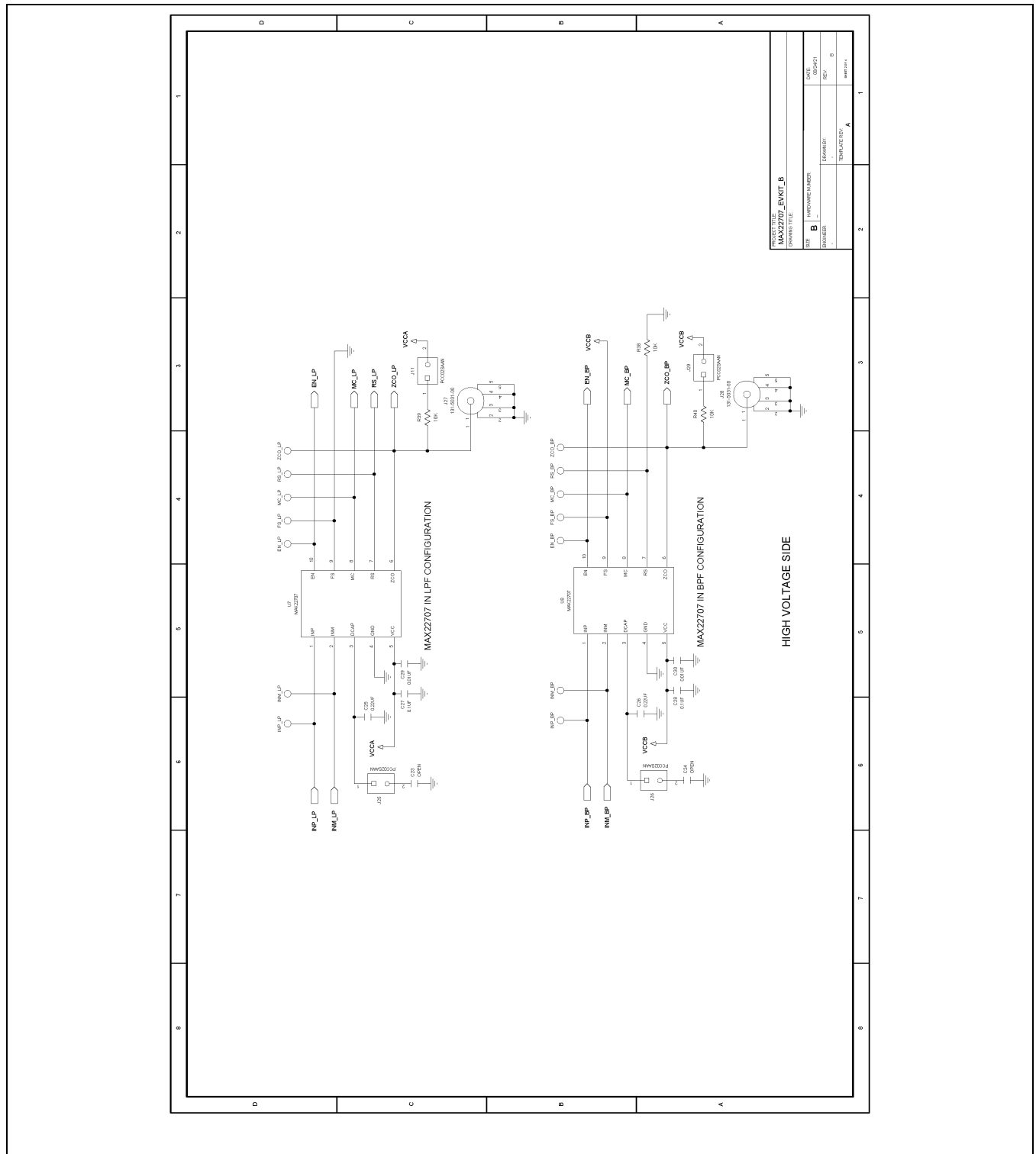

MAX22707 EV Kit Schematic (Continued)

LOW PASS CONFIGURATION INPUT NETWORK

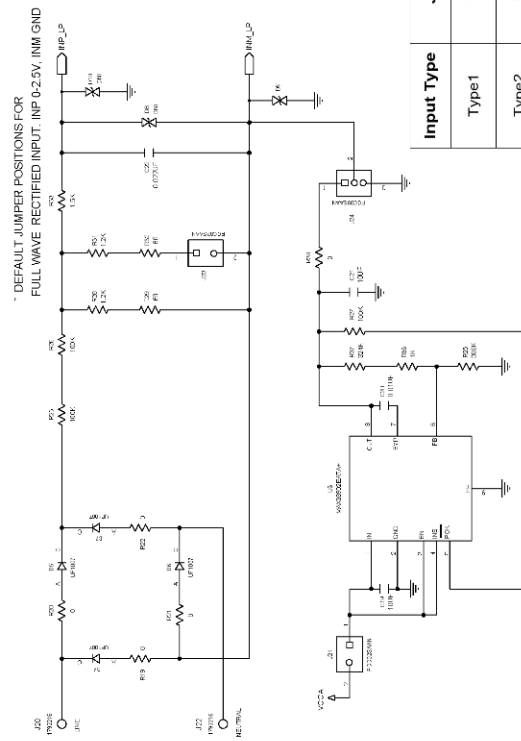

Input Type	J23	J24	Bridge Network
Type1	1-2	2-3 → GND	Remove: R19, R22, D4, D7 D5, D6: Replace with wire short
Type2	1-2	1-2 → 1.25V	Remove: R19, R22, D4, D7 D5, D6: Replace with wire short
Type3	Not Installed	2-3 → GND	Default
Type 4	Not Installed	2-3 → GND	Remove: R19, R22

HIGH VOLTAGE SIDE

MAX22707 EV Kit Schematic (continued)

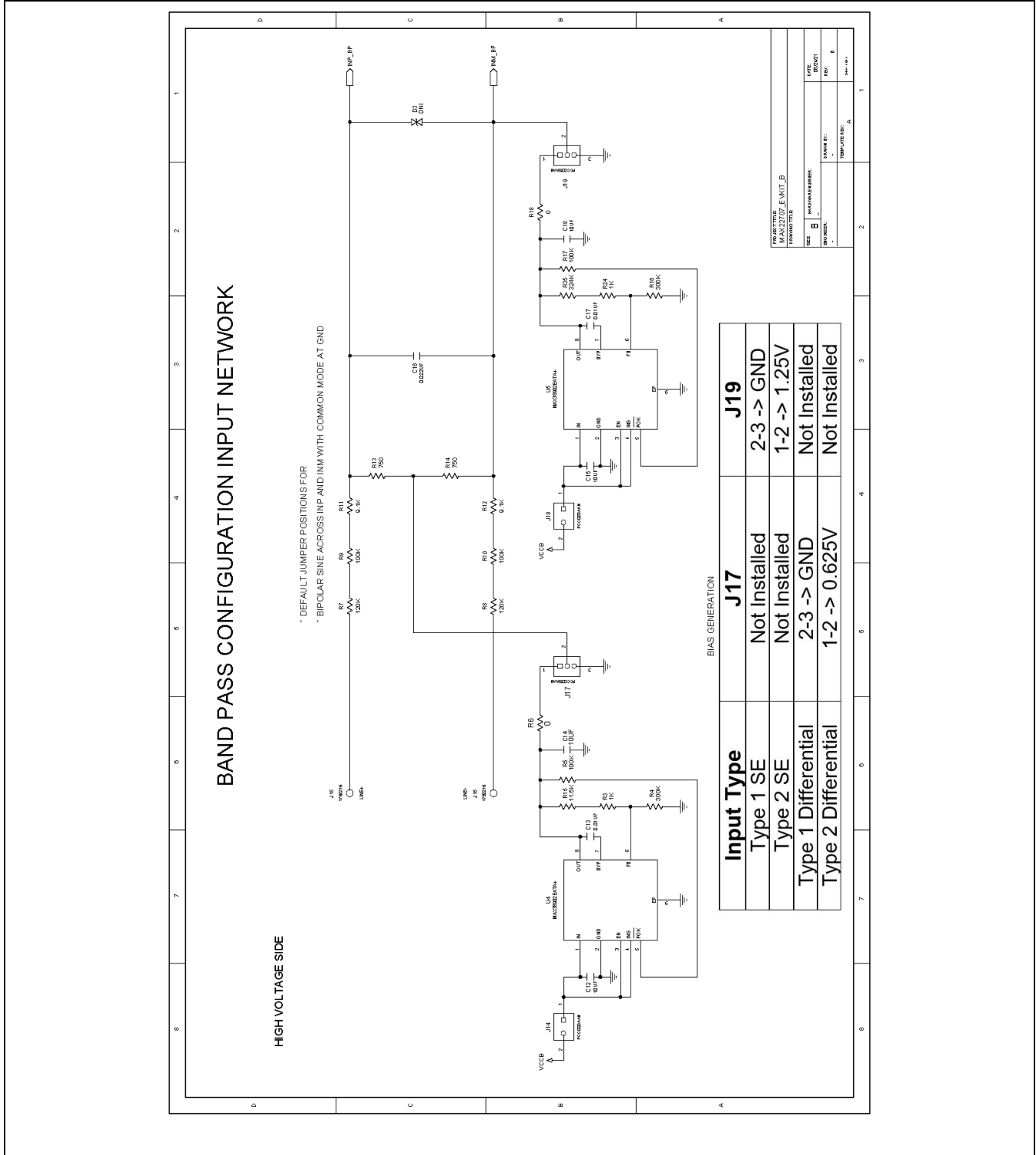

MAX22707 EV Kit PCB Layout

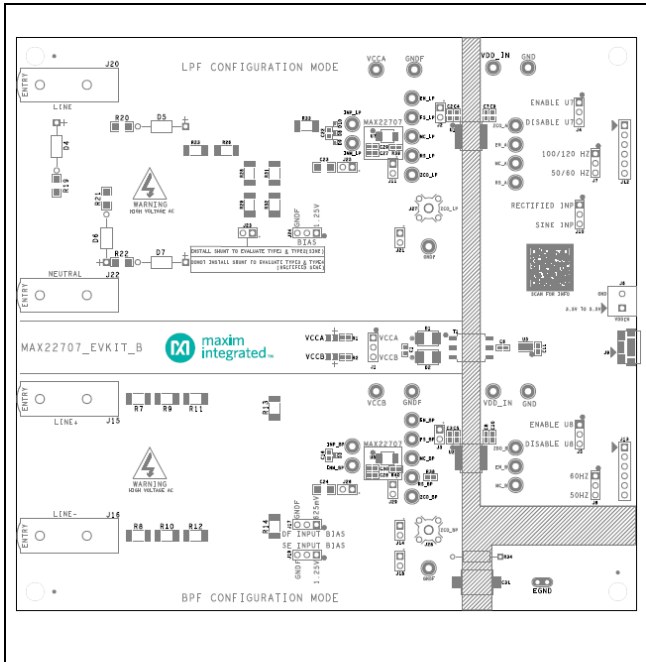

MAX22707 EV Kit Component Placement Guide—Top Silkscreen

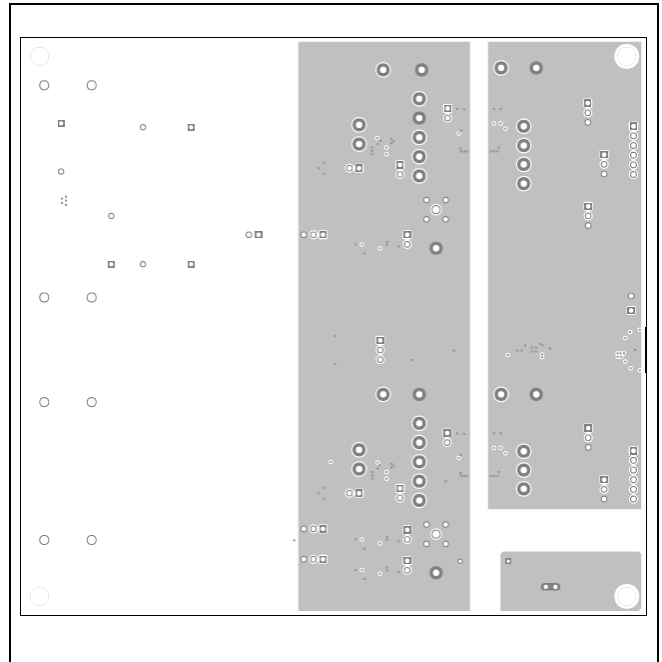

MAX22707 EV Kit PCB Layout—Layer 2

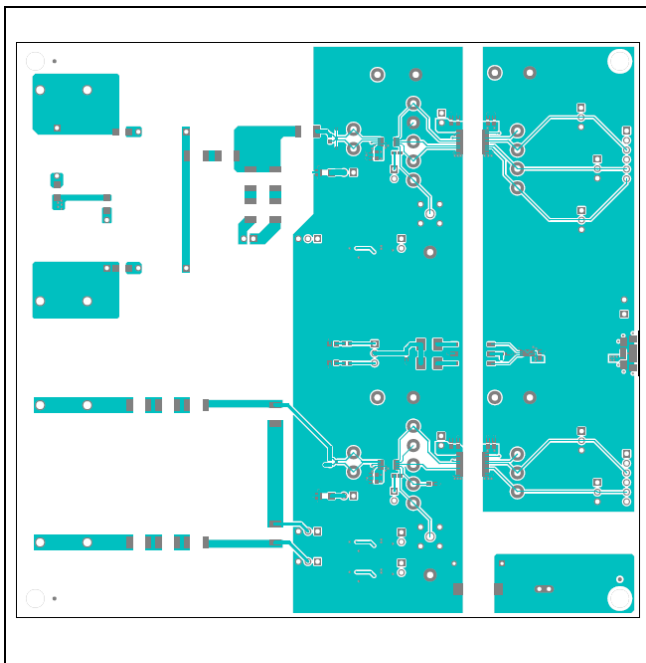

MAX22707 EV Kit PCB Layout—Top

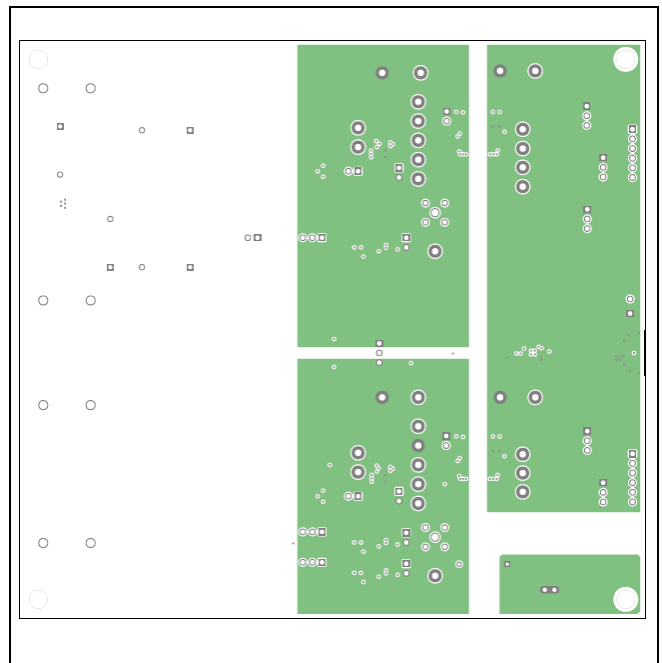

MAX22707 EV Kit PCB Layout—Layer 3

MAX22707 EV Kit PCB Layout (continued)

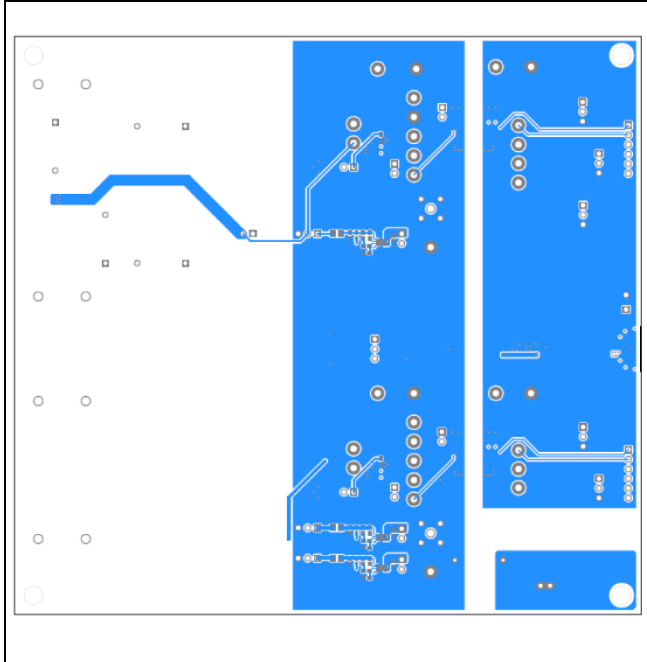

MAX22707 EV Kit PCB Layout—Bottom

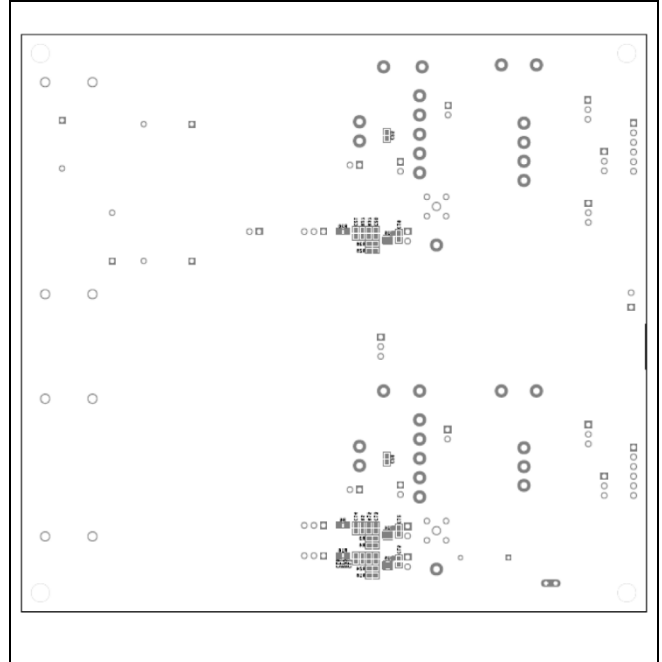

MAX22707 EV Kit Component Placement Guide—Bottom Silkscreen

Revision History

REVISION NUMBER	REVISION DATE	DESCRIPTION	PAGES CHANGED
0	12/21	Initial release	—



X-ON Electronics

Largest Supplier of Electrical and Electronic Components

Click to view similar products for [Power Management IC Development Tools](#) category:

Click to view products by [Maxim](#) manufacturer:

Other Similar products are found below :

[EVB-EP5348UI](#) [MIC23451-AAAYFL EV](#) [MIC5281YMME EV](#) [124352-HMC860LP3E](#) [DA9063-EVAL](#) [ADP122-3.3-EVALZ](#) [ADP130-0.8-EVALZ](#) [ADP130-1.8-EVALZ](#) [ADP1740-1.5-EVALZ](#) [ADP1870-0.3-EVALZ](#) [ADP1874-0.3-EVALZ](#) [ADP199CB-EVALZ](#) [ADP2102-1.25-EVALZ](#) [ADP2102-1.875EVALZ](#) [ADP2102-1.8-EVALZ](#) [ADP2102-2-EVALZ](#) [ADP2102-3-EVALZ](#) [ADP2102-4-EVALZ](#) [AS3606-DB](#) [BQ25010EVM](#) [BQ3055EVM](#) [ISLUSBI2CKIT1Z](#) [LP38512TS-1.8EV](#) [EVAL-ADM1186-1MBZ](#) [EVAL-ADM1186-2MBZ](#) [ADP122UJZ-REDYKIT](#) [ADP166Z-REDYKIT](#) [ADP170-1.8-EVALZ](#) [ADP171-EVALZ](#) [ADP1853-EVALZ](#) [ADP1873-0.3-EVALZ](#) [ADP198CP-EVALZ](#) [ADP2102-1.0-EVALZ](#) [ADP2102-1-EVALZ](#) [ADP2107-1.8-EVALZ](#) [ADP5020CP-EVALZ](#) [CC-ACC-DBMX-51](#) [ATPL230A-EK](#) [MIC23250-S4YMT EV](#) [MIC26603YJL EV](#) [MIC33050-SYHL EV](#) [TPS60100EVM-131](#) [TPS65010EVM-230](#) [TPS71933-28EVM-213](#) [TPS72728YFFEVM-407](#) [TPS79318YEQEVM](#) [UCC28810EVM-002](#) [XILINXPWR-083](#) [LMR22007YMINI-EVM](#) [LP38501ATJ-EV](#)