



MAX2470/MAX2471 Evaluation Kits

General Description

The MAX2470/MAX2471 evaluation kits (EV kits) simplify the evaluation of the MAX2470/MAX2471 VCO buffer amplifiers. They enable testing of the devices' performance and require no additional support circuitry. All inputs and outputs use SMA connectors to facilitate easy connection of RF test equipment.

The MAX2470 EV kit is assembled with the MAX2470 and provides one high-impedance input (with pads to terminate to 50Ω) and a pair of matched 50Ω differential outputs. JU1 sets the logic level at the HI/LO bias-control input, allowing for selection between 10MHz to 500MHz and 10MHz to 200MHz operation. The MAX2471 EV kit is assembled with the MAX2471 and provides two high-impedance inputs (with pads to terminate to 50Ω) and a pair of matched 50Ω differential outputs.

Features

- ♦ Easy Evaluation of MAX2470/MAX2471
- ♦ +2.7V to +5.5V Single-Supply Operation
- ♦ On-Board Input-Frequency Range Selection (MAX2470)
- ♦ Single-Ended (MAX2470) or Differential (MAX2471) Inputs
- ♦ All Critical Peripheral Components Included

Ordering Information

PART	TEMP. RANGE	IC PACKAGE	SOT TOP MARK
MAX2470EVKIT	-40°C to +85°C	SOT23-6	AAAX
MAX2471EVKIT	-40°C to +85°C	SOT23-6	AAAY

Component Suppliers

SUPPLIER	PHONE	FAX	URL
AVX	803-946-0690	803-626-3123	http://www.avx-corp.com
E.F. Johnson	402-474-4800	402-474-4858	http://www.ef-johnson.com

Component Lists

Common Components for MAX2470/MAX2471 EV Kits

DESIGNATION	QTY	DESCRIPTION
C1, C2, C3, C5	4	2200pF, 10%, 25V ceramic-chip capacitors (0603)
C6	1	10μF, 10%, 10V tantalum capacitor AVX TAJC106K016
R3, R4	2	Optional 50Ω input-termination resistors (0603) (not installed)
J1, J2, J3	3	SMA connectors (PC top mount) E.F. Johnson 142-0701-216
J5, J6	2	Test points Mouser 151-203
None	1	MAX2470/2471EVKIT PC board
None	1	MAX2470/MAX2471 EV kit manual

Additional Components for MAX2470 EV Kit

DESIGNATION	QTY	DESCRIPTION
C7	1	2200pF, 10%, 25V ceramic-chip capacitor (0603)
JU1	1	3-pin header (0.100" centers) Digi-key S1012-36-ND
JU1	1	Shunt (jumper) Digi-key S9000-ND
R1	1	0Ω, 5% chip resistor (0603)
R2	1	1kΩ, 5% chip resistor (0603)
U1	1	MAX2470EUT

Additional Components for MAX2471 EV Kit

DESIGNATION	QTY	DESCRIPTION
C4	1	2200pF, 10%, 25V ceramic-chip capacitor (0603)
J4	1	SMA connector (PC top mount) E.F. Johnson 142-0701-216
U1	1	MAX2471EUT

Evaluate: MAX2470/MAX2471

MAX2470/MAX2471 Evaluation Kits

Quick Start

The MAX2470/MAX2471 EV kits are fully assembled and factory tested. Follow the instructions in the *Connections and Setup* section for proper device evaluation.

Test Equipment Required

This section lists the recommended test equipment to verify the operation of the MAX2470/MAX2471. It is intended as a guide only, and some substitutions are possible.

- One DC power supply capable of supplying a minimum of 10mA at +2.7V to +5.5V.
- One RF spectrum analyzer capable of making measurements over the bandwidth of the MAX2470/MAX2471 and a few harmonics, such as the HP 8561E.
- One RF signal generator capable of delivering 0dBm output power at 500MHz, such as the HP 8648C signal generator.
- Two baluns with a 2:1 turns ratio and an operating range encompassing 10MHz to 500MHz, such as the Macom model number 96341 180° hybrid (balun). Fully differential measurements for the MAX2470 require a single 180° hybrid at the output. Fully differential measurements for the MAX2471 require two 180° hybrids: one at the input, and one at the output.

Connections and Setup

- 1) Verify the DC power supply is set to less than +5.5V and is off before connecting the supply to the EV kit. A good starting point is +3.0V. Connect the power supply between V_{CC} and GND and turn it on.
- 2) Set the output power of the signal generator to -20dBm at 200MHz. Disable the output, then connect the output of the signal generator to the IN SMA connector of the MAX2470 EV kit board. For the MAX2471, use a balun between the signal generator and the differential inputs (IN and $\overline{\text{IN}}$).

- 3) For a differential power-gain measurement, connect a balun between the outputs of the buffer and the spectrum analyzer.

Analysis

Adjust the frequency span, center frequency, and amplitude of the spectrum analyzer to observe the signal peak at 200MHz; the output signal power should read approximately -6dBm for the MAX2470 and -5dBm for the MAX2471.

Detailed Description

This section describes the circuitry surrounding the IC in the MAX2470/MAX2471 EV kits. For more detailed information about the device operation, please consult the MAX2470/MAX2471 data sheet.

Figure 1 is the schematic for the MAX2470/MAX2471 EV kits. Capacitors C1, C2, C3, and C4 are 2200pF DC-blocking capacitors; this value contributes minimal reactance to the signal paths, down to 10MHz. Capacitors C5 and C6 form the V_{CC} decoupling network. Note the location of each component; a relatively large 10μF tantalum capacitor, C6, is located near the V_{CC} connector. Near to C6, a much smaller 2200pF decoupling capacitor, C5, reduces any high-frequency interference.

The EV kit includes pads for R3 and R4 that can facilitate simple termination of the input(s). For the MAX2470 EV kit, R2 and C7 provide high-frequency filtering to prevent excess noise from coupling into the IC.

On the MAX2470 EV kit, jumper JU1 selects the state of the HI/ $\overline{\text{LO}}$ input on the MAX2470. Selecting the "LO" setting optimizes the MAX2470 for input frequencies from 10MHz to 200MHz. Selecting the "HI" setting optimizes the MAX2470 for input frequencies from 10MHz to 500MHz.

MAX2470/MAX2471 Evaluation Kits

Evaluate: MAX2470/MAX2471

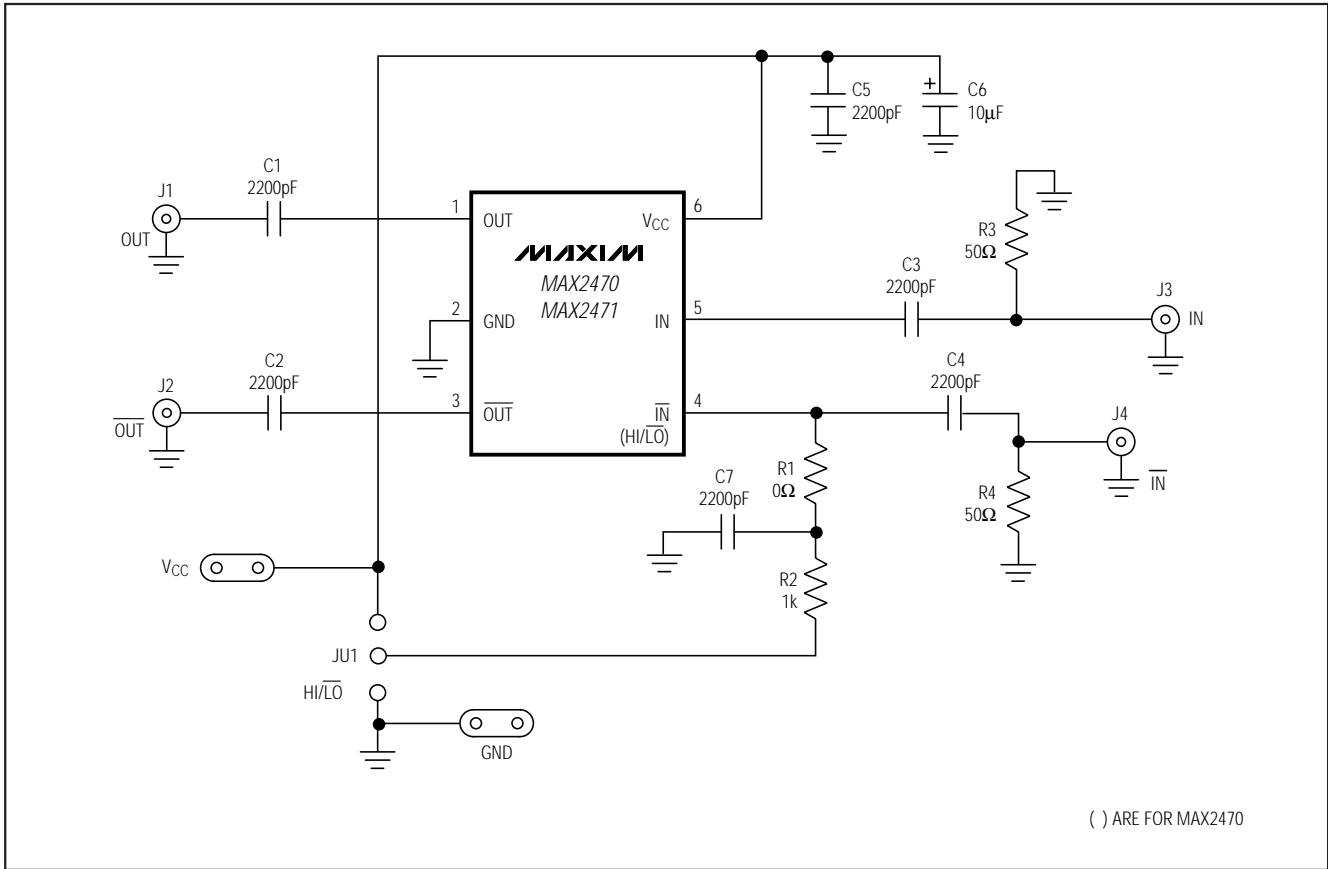

Figure 1. MAX2470/MAX2471 EV Kit Schematic

MAX2470/MAX2471 Evaluation Kits

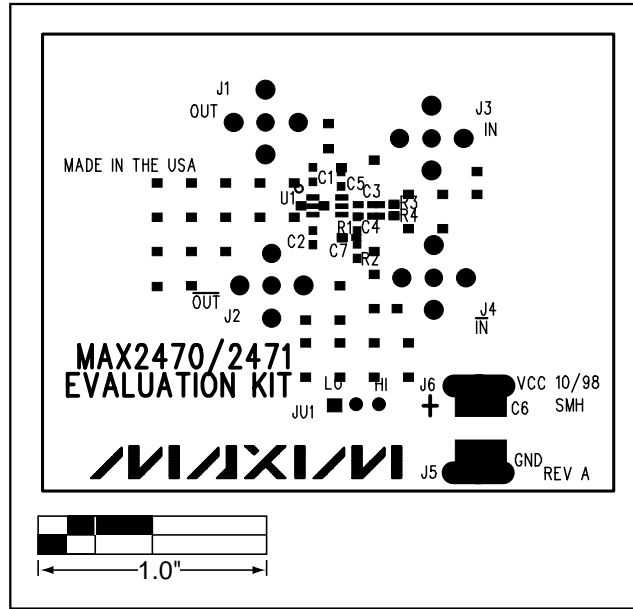

Figure 2. MAX2470/MAX2471 EV Kit Component Placement Guide—Component Side

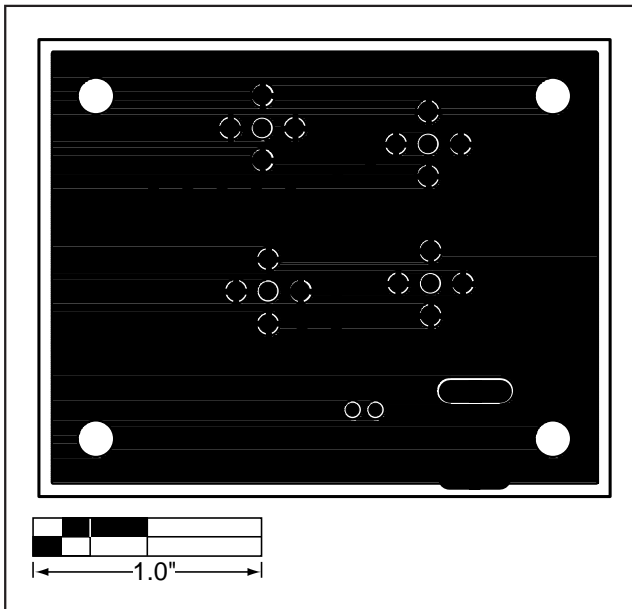

Figure 3. MAX2470/MAX2471 EV Kit PC Board Layout—Ground Plane

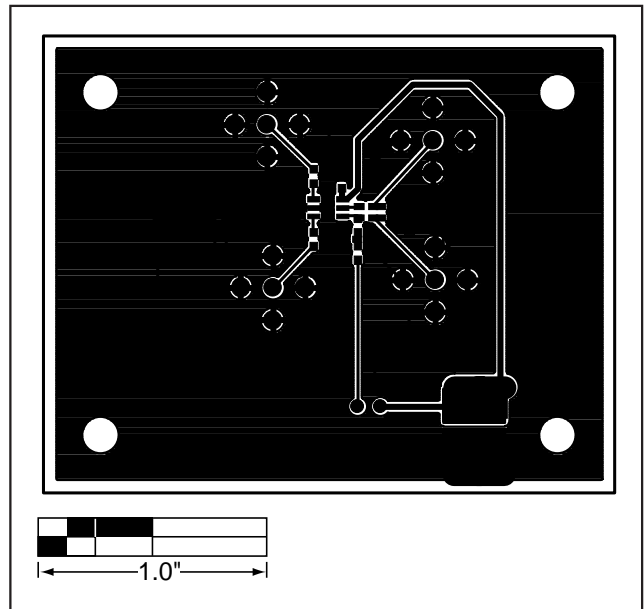

Figure 4. MAX2470/MAX2471 EV Kit PC Board Layout—Component Side

Maxim cannot assume responsibility for use of any circuitry other than circuitry entirely embodied in a Maxim product. No circuit patent licenses are implied. Maxim reserves the right to change the circuitry and specifications without notice at any time.

4 _____ Maxim Integrated Products, 120 San Gabriel Drive, Sunnyvale, CA 94086 408-737-7600

X-ON Electronics

Largest Supplier of Electrical and Electronic Components

Click to view similar products for [Amplifier IC Development Tools](#) category:

Click to view products by [Maxim](#) manufacturer:

Other Similar products are found below :

[AD8033AKS-EBZ](#) [AD8044AR-EBZ](#) [AD744JR-EBZ](#) [AD8023AR-EBZ](#) [AD848JR-EBZ](#) [ADA4922-1ACP-EBZ](#) [EVAL-ADCMP553BRMZ](#)
[EVAL-ADCMP608BKSZ](#) [MIOP 42109](#) [EVAL-ADCMP609BRMZ](#) [ADA4950-1YCP-EBZ](#) [MAX2634EVKIT](#) [ISL28158EVAL1Z](#) [MADL-](#)
[011014-001SMB](#) [AD8137YCP-EBZ](#) [EVAL-ADA4523-1ARMZ](#) [EVAL01-HMC1013LP4E](#) [MCP6XXXEV-AMP3](#) [MCP6XXXEV-AMP4](#)
[MCP6XXXEV-AMP2](#) [ISL28006FH-100EVAL1Z](#) [551012922-001/NOPB](#) [EVAL-ADCMP603BCPZ](#) [AMC1200EVM](#) [AD8417RM-EVALZ](#)
[DEM-OPA-SOT-1A](#) [DEM-OPA-SO-1C](#) [DEM-BUF-SOT-1A](#) [OPA2836IDGSEVM](#) [AD633-EVALZ](#) [AD8250-EVALZ](#) [AD8418R-EVALZ](#)
[ISL28433SOICEVAL1Z](#) [ISL28233SOICEVAL1Z](#) [ISL28208SOICEVAL2Z](#) [ISL28207SOICEVAL2Z](#) [ISL28006FH-50EVAL1Z](#)
[ISL28005FH-50EVAL1Z](#) [120257-HMC613LC4B](#) [DC1591A](#) [DC1150A](#) [DC1115A](#) [DC954A-C](#) [DC306A-A](#) [DC1192A](#) [131679-](#)
[HMC813LC4B](#) [OPA2835IDGSEVM](#) [LMH730220/NOPB](#) [MAAP-011246-1SMB](#) [118329-HMC627ALP5](#)