

MAX25221 Evaluation Kit/ MAX25221 Evaluation System

Evaluates: MAX25220, MAX25221

General Description

The MAX25221 evaluation kit (EV kit) is a fully assembled and tested surface-mount PCB used to evaluate MAX25221 automotive 4-Channel TFT-LCD Power Supply with VCOM Buffer and MAX25220 automotive 4-Channel TFT-LCD Power Supply without VCOM. Each output rail (AVDD, NAVDD, VGON, VGOFF and VCOM) can be independently adjusted via I²C. The EV kit demonstrates the device's features: adjustable output voltage, fault protection, VCOM temperature compensation, and non-volatile memory programming. The EV kit exposes an I²C interface which can operate in conjunction with the MINIUSB+ adapter or a third party I²C master like a general-purpose microcontroller. The EV kit also includes Windows®-compatible software that provides a simple graphical user interface (GUI) for exercising the features of the IC. The EV system includes both the EV kit and the MINIUSB+ adapter board.

Benefits and Features

- 2.65V to 5.5V Input Range
- Default Output Voltages
 - 6.8V Output at 200mA (Boost Converter)
 - -6.8V Output at -200mA (Inverting Regulator)
 - 12V Output at 15mA (Positive-Charge Pump Regulator)
 - -10V Output at 15mA (Negative-Charge Pump Regulator)
 - -2.49V Output at 100mA (VCOM Buffer)
- Selectable Switching Frequency (2.1MHz or 420kHz) with Spread-Spectrum Option. (The EV kit components will fit the 2.1MHz frequency. Using 420kHz will need hardware change.)
- Dedicated GUI
- Full Sequencing Flexibility
- Proven PCB Layout
- Fully Assembled and Tested

MAX25221 EV Kit Files

FILE	DESCRIPTION
MAX25221GUISetupVxx.exe	Windows GUI Installer

Windows is a registered trademark and service mark of Microsoft Corporation.

Quick Start

Required Equipment

- MAX25221 EV kit
- 2.65 to 5.5V, 3A power supply
- Voltmeter
- MINIUSB+ interface board with USB cable
- User-supplied Windows-compatible PC with a spare USB port

Note: In the following sections, software-related items are identified by bolding. Text in **bold** refers to items directly from the EV kit software. Text in **bold and underlined** refers to items from the Windows operating system.

Procedure

The EV kit is fully assembled and tested. To verify board operation, follow the steps:

Stand Alone

- Verify that shunts are installed across pins 1-2 on jumpers J1–J4. Ensure that J5 has no jumper installed.
- Connect the positive terminal of the power supply to the TFT_POWER_IN pad and the negative terminal to the GND1 PCB pad.
- Set the power supply TFT_POWER_IN at 5V.
- Turn on the power supply.
- Verify that the green LED (DS1) is on.
- Verify that the boost converter (AVDD PCB pad) is 6.8V.
- Verify that the inverting converter (NAVDD PCB pad) is -6.8V.
- Verify that the positive-gate voltage regulator (VGON PCB pad) is +12V.
- Verify that the negative-gate voltage regulator (VGOFF PCB pad) is -10V.
- Verify that the VCOM buffer (VCOM PCB pad) regulator is -2.49V. (Only for MAX25221.)

Ordering Information appears at end of data sheet.

MAX25221 Evaluation Kit/ MAX25221 Evaluation System

Evaluates: MAX25220, MAX25221

I²C Mode

- Visit www.maximintegrated.com/evkitsoftware download the latest version of the EV kit software, MAX25221GUISetupVxx.exe.
- Install the EV kit software (GUI) on your PC by running the MAX25221GUISetupVxx.exe program.
- The EV kit software application will be installed together with the required MINIUSB+ drivers.
- Verify that shunts are installed across pins 1-2 on jumpers J1-J3, J5, J7, J9-J11, and J17.
- Verify that shunts are installed across pins 2-3 on jumper J12.
- Connect the MINIUSB+ interface board's P3 header to the J14 header on the EV kit.
- Connect the positive terminal of the power supply to the TFT_POWER_IN pad and the negative terminal to the GND1 PCB pad.
- Set the power supply VIN at 5V.
- Turn on the power supply.
- Verify that the green LED (DS1) is on.
- Launch the EV kit software application.
- From the EV kit software toolbar, select **Device** → **Scan for Address**. The GUI scans the I²C bus for available slave addresses on the bus and selects the first one (in this case, the MAX25221 I²C address with J5 settings: 52H). Press **OK** once the MAX25221/MAX25220 I²C address has been found. [Figure 1](#), is a screen capture of MAX25221 Evaluation Kit Software (GUI).
- Verify that the status bar in the bottom-right corner of the GUI displays **EV Kit: Connected**.
- In the **GENERAL SETTINGS** group box press **START button**.
- In the **INDICATORS SEQ_ON** and **FLT_PIN** status should be green.
- All channels are turned on outputting AVDD 6.8V, NAVDD -6.8V, VGON 12V, VGOFF -10V, VCOM -2.49V.
- For more details on how to use the GUI and all the features available, click on the GUI **Help** menu item.

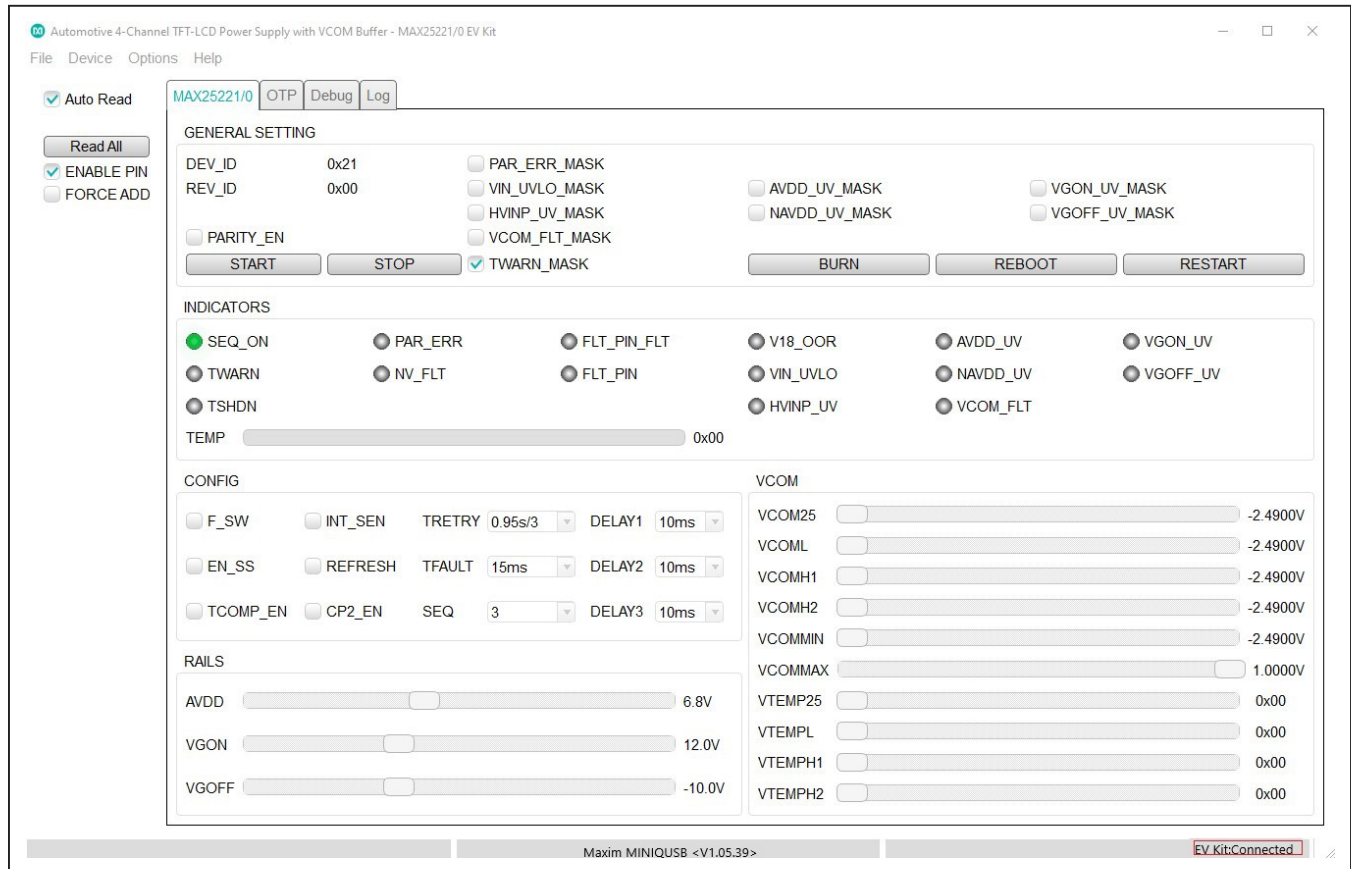

Figure 1. MAX25221 Evaluation Kit Software (GUI)

Detailed Description of Hardware

Jumper Setting

In the following tables, several jumper settings illustrate features of the MAX25221 EV kit.

Power LED Enable (J1)

A green LED (DS1) is used to indicate that the EV kit is powered on.

The LED can be disconnected from the power supply, allowing precise current-consumption evaluation (see [Table 1](#)).

Fault LED Enable (J2)

A red LED (DS2) is used to indicate a fault condition. The LED can be disconnected from the power supply, allowing precise current-consumption evaluation (see [Table 2](#)).

SCL Pull Up (J3)

See [Table 3](#) for jumper functions SCL Pull Up (J3).

Table 1. Jumper Functions (J1)

SHUNT POSITION	DS1 POWER LED
1-2*	Connected
Open	Disconnected

*Default position.

Table 2. Jumper Functions (J2)

SHUNT POSITION	DS2 FAULT LED
1-2*	Connected
Open	Disconnected

*Default position.

Table 3. Jumper Functions SCL Pull Up (J3)

SHUNT POSITION	SCL VOLTAGE PULL UP
1-2	On-board 1.5k Ω Pull up to DVDD
Open	External Pull up

*Default position.

Enable (J4)

The MAX25221/MAX25220 IC can be disabled acting on the EN pin, reducing the current consumption to its minimum value. Furthermore, an external digital signal can be used to enable/disable the IC (see [Table 4](#) and [Table 6](#)).

ADD_SEL I²C Slave Address—Mode (J5)

The IC's 7-bit I²C slave address can be selected between two options through the J5 jumper setting (see [Table 5](#)). Additionally, the stand-alone mode can be selected with this jumper.

External ADD control (J6)

For future improvement.

Default condition Open.

External Enable (J7)

The MAX25221/MAX25220 IC can be enabled or disabled acting GUI command **ENABLE_P** or external digital command (see [Table 6](#)).

Table 4. Jumper Functions Enable (J4)

SHUNT POSITION	MAX25221/MAX25220
1-2*	Enable
Open**	External control from EN loop on board edge
2-3	Disable

*Default position.

** J7 must be open.

Table 5. Jumper Functions (J5)

SHUNT POSITION	MODE 7-BIT I ² C SLAVE ADDRESS
1-2*	I ² C Mode: 0x52
2-3	I ² C Mode: 0x42
Open	Stand Alone

*Default position.

Table 6. Jumper Functions (J7)

SHUNT POSITION	MAX25221/MAX25220
1-2*	Enabled from GUI Control [ENABLE_PIN]
Open	Externally controlled through digital signal (EN at board edge)

*Default position.

NVM Programming (J8, J13)

The EV kit is equipped with a low voltage boost regulator able to provide the VPROG voltage (8.5V) needed for NVM programmability. The VPROG is controlled by the GUI and enabled only during burning procedure. In order to use this feature, J13 jumper must be installed and J8 can be used to select the boost circuitry input voltage (see [Table 7](#) and [Table 8](#)).

FLT (J9)

Allows the Fault signal FLTB to be sent to GUI or an external device (see [Table 9](#)).

SCL (J10)

The SCL can be connected to MINIQUSB+ or external device (see [Table 10](#)).

Table 7. Jumper Functions (J8)

SHUNT POSITION	VPROG BOOST INPUT VOLTAGE
1-2	MINIQUSB+ 3.3V
2-3*	VIN

*Default position.

Table 8. Jumper Functions (J13)

SHUNT POSITION	VPROG BOOST OUTPUT VOLATGE
1-2*	+8.5V power VPROG pin
Open	

*Default position.

Table 9. Jumper Functions (J9)

SHUNT POSITION	FLT SIGNAL
1-2*	MINIQUSB+ 3.3V
Open	External Signal (FLT at board edge)

*Default position.

Table 10. Jumper Functions (J10)

SHUNT POSITION	SCL SIGNAL
1-2*	MINIQUSB+ 3.3V
Open	External Signal

*Default position.

SDA (J11)

The SDA could be connected to GUI or external device (see [Table 11](#)).

Digital Domain Voltage (J12)

The EV kit exposes open-drain digital signals (FLT, SDA, and SCL) that are pulled up to what is referred as the “digital domain voltage.”

Digital domain voltage can be selected between the EV kit input voltage (VIN) and the fixed 3.3V provided by the MINIQUSB+. Alternatively, you can force an external voltage as digital reference (see [Table 12](#)).

SDA Pull Up (J17)

See [Table 13](#) for jumper functions SDA Pull Up (J17).

Table 11. Jumper Functions (J11)

SHUNT POSITION	SDA SIGNAL
1-2*	MINIQUSB+ 3.3V
Open	External Signal

*Default position.

Table 12. Jumper Functions (J12)

SHUNT POSITION	DIGITAL DOMAIN
1-2	MINIQUSB+ 3.3V
2-3*	VIN
Open	Externally provided (DVDD test point)

*Default position.

Table 13. Jumper Functions SDA Pull Up (J17)

SHUNT POSITION	SDA VOLTAGE PULL UP
1-2*	On-board 1.5kΩ Pull up to DVDD
open	External Pull up

*Default position.

MAX25221 Evaluation Kit/ MAX25221 Evaluation System

Evaluates: MAX25220, MAX25221

VCOM only for MAX25221

The VCOM output voltage is programmed using I²C to a value between -2.49V and +1V with output peak currents between +/-120 mA.

The VCOM output could operate in two different ways.

VCOM without temperature compensation (see [Table 14](#)).

VCOM with temperature compensation.

The VCOM output voltage can be compensated for temperature changes using an external or internal temperature sensors, see [Table 15](#), [Table 16](#), and [Table 17](#).

For details of how to use the VCOM temperature compensation function, refer to the sections VCOM Temperature Compensation and VCOM Temperature Compensation Example in the MAX25220/MAX25221 Datasheet.

Table 14. VCOM without Temperature Compensation Registers

REGISTER	DESCRIPTION	
TCOMP_EN	TCOMP_EN" bit in the DELAYVCOM_LS Register [0X08 Bit 1]	[0] disables this functionality.
VCOM25	Sets the VCOM value between the range define from the registers VCOMMIN and VCOMMAX	
VCOMMIN	Define Minimum value of VCOM	
VCOMMAX	Define Maximum value of VCOM	

*Default position.

Table 15. VCOM Temperature Compensation Setting Registers

REGISTER	DESCRIPTION	
TCOMP_EN	TCOMP_EN" bit in the DELAYVCOM_LSB Register [0X08 Bit 1]	[1] Enable [0] Disable
INT_SEN	int_sensor bit in the CONFIG register [0X07 Bit 7] select the sensor	[0] Internal Sensor [1]* External T Sensor

*Default position.

Ordering Information

PART	TYPE
MAX25221EVKIT#	EV Kit
MAX25221EVSYS#	EV System

#Denotes RoHS compliant.

VPROG

The EV kit includes a Boost converter in order to supply 8.5V 25mA for programming. To perform non-volatile programming this voltage should be connected to the VPROG pin.

Verify the Jumpers status See [Table 7](#) and [Table 8](#).

Using the GUI send a BURN command, the VPROG_EN connected to SHDN pin enable the Boost converter for a time of 20ms.

All values in registers 0x07 to 0x15 will be stored in non-volatile memory.

Table 16. VTEMP Registers

REGISTER	DESCRIPTION
VTEMPL	Voltage at TEMP* pin corresponding to low-temperature breakpoint in VCOM compensation curve.
VTEMP25	Voltage at TEMP* pin at 25°C
VTEMP_H1	Voltage at TEMP pin corresponding to first high-temperature breakpoint in VCOM compensation curve.
VTEMP_H2	Voltage at TEMP pin corresponding to second high-temperature breakpoint in VCOM compensation curve.

Table 17. VCOM Registers

REGISTER	DESCRIPTION
VCOM_L	Delta VCOM at the temperature corresponding to VTEMP_L. This value sets the difference between the VCOM value at 25°C and that at VTEMP_L.
VCOM25	Set the VCOM value at 25°C
VCOM_H1	Delta VCOM at VTEMP_H1. This value sets the difference between the VCOM value at 25°C and that at VTEMP_H1.
VCOM_H2	Delta VCOM at VTEMP_H2. This value sets the difference between the VCOM value at VTEMP_H1 and that at VTEMP_H2.

MAX25221 Evaluation Kit/
MAX25221 Evaluation System

Evaluates: MAX25220, MAX25221

MAX25221 Frequency Switch (FSW) 2.1MHz EV Kit Bill of Materials

The table below refers only to MAX25221 FSW 2.1MHz. For MAX25221 FSW 420kHz and MAX25220 see the dedicated tables to follow.

ITEM	REF_DES	DNI/DNP	QTY	MFG PART #	MANUFACTURER	VALUE	DESCRIPTION	COMMENTS
1	ADD, DVDD, IREF+, IREF-, TEMP+, TEMP-	-	6	5005	KEystone	N/A	TEST POINT; PIN DIA=0.125IN; TOTAL LENGTH=0.35IN; BOARD HOLE=0.083IN; RED; PHOSPHOR BRONZE WIRE SILVER PLATE FINISH;	
2	AVDD, EN, FLT, GND1-GND7, HVINP, NAVDD, SCL, SDA, TFT_POWER_IN, VCOM, VGOFF, VGON, VIN, VPROG	-	20	9020	BUSS	WEICO WIRE	MAXIMPAD	EVK KIT PARTS; MAXIM PAD; WIRE; NATURAL; SOLID; WEICO WIRE; SOFT DRAWN BUS TYPE-S; 20AWG
3	C1-C3, C7, C19, C37, C38, C40	-	8	CL10B106MQ8NRN	SAMSUNG ELECTRONICS	10UF		CAPACITOR; SMT (0603); CERAMIC CHIP; 10UF; 6.3V; TOL=20%; MODEL=CL SERIES; TG=-55 DEGC TO +125 DEGC; TC=X7R
4	C4, C10, C11, C13, C21, C23, C39	-	7	GRM188R71E105KA12; CGA3E1X7R1E105K; TMK107B7105KA; 0603C105KAT2A; GCM188R71E105KA64; C1608X7R1E105K080AE; CGA3E1X7R1E105K080AC	MURATA;TDK;TAIYO YUDEN; AVX;MURATA;TAIYO YUDEN;TDK	1UF		CAPACITOR; SMT (0603); CERAMIC CHIP; 1UF; 25V; TOL=10%; TG=-55 DEGC TO +125 DEGC; TC=X7R
5	C5, C9, C12, C22, C31, C52	-	6	CC0603KRX7R0BB104; GRM188R72A104KA35; HMK107B7104KA; 06031C104KAT2A; GRM188R72A104K	YAGEO;MURATA;TAIYO YUDEN; AVX;MURATA	0.1UF		CAPACITOR; SMT (0603); CERAMIC CHIP; 0.1UF; 100V; TOL=10%; TG=-55 DEGC TO +125 DEGC; TC=X7R
6	C6, C8, C34, C36	-	4	GRM188R72A223KAC4; C0603C223K1RAC; HMK107B7223KA; C1608X7R2A223K080AA	MURATA;KEMET;TAIYO YUDEN;TDK	22000PF		CAPACITOR; SMT (0603); CERAMIC CHIP; 22000PF; 100V; TOL=10%; TG=-55 DEGC TO +125 DEGC; TC=X7R
7	C14, C24-C26	-	4	C0603C104K8RAC	KEMET	0.1UF		CAPACITOR; SMT (0603); CERAMIC CHIP; 0.1UF; 10V; TOL=10%; MODEL=C0603 SERIES; TG=-55 DEGC TO +125 DEGC; TC=X7R
8	C18	-	1	C0603C103K5RAC; GRM188R71H103K; C0603X7R500-103KNE; C1608X7R1H103K080AE	KEMET;MURATA;VENKEL LTD.;TDK	0.01UF		CAPACITOR; SMT; 0603; CERAMIC; 0.01uF; 50V; 10%; X7R; -55degC to + 125degC
9	C27, C29	-	2	C1210C106M3RAC; GRM32DR71E106M; C3225X7R1E106M250AC	KEMET;MURATA;TDK	10UF		CAPACITOR; SMT (1210); CERAMIC CHIP; 10UF; 25V; TOL=20%; MODEL=; TG=-55 DEGC TO +125 DEGC; TC=X7R;
10	C30	-	1	GRM188R61H25K5E11	MURATA	2.2UF		CAPACITOR; SMT (0603); CERAMIC CHIP; 2.2UF; 50V; TOL=10%; TG=-55 DEGC TO +85 DEGC; TC=X5R
11	C33, C35	-	2	UMK107BJ105KA; C1608X5R1H105K080AB; CL10A105KB8NNN; GRM188R61H105KAAL	TAIYO YUDEN;TDK;SAMSUNG; MURATA	1UF		CAPACITOR; SMT (0603); CERAMIC CHIP; 1UF; 50V; TOL=10%; MODEL=_MK SERIES; TG=-55 DEGC TO +85 DEGC
12	C47	-	1	C0603C100K1GAC	KEMET	10PF		CAPACITOR; SMT (0603); CERAMIC CHIP; 10PF; 100V; TOL=10%; MODEL=C0G; TG=-55 DEGC TO +125 DEGC; TC=+/-
13	C50, C51	-	2	GCM31CR71A226KE02	MURATA	22UF		CAP; SMT (1206); 22UF; 10%; 10V; X7R; CERAMIC CHIP
14	D3	-	1	NRVTS245ESFT1G	ON SEMICONDUCTOR	NRVTS245ESFT1G		DIODE; SCH; SMT (SOD-123FL); PIV=45V; IF=2.0A
15	D4-D6	-	3	BAT54S	FAIRCHILD SEMICONDUCTOR	BAT54S		DIODE; SCH; SCHOTTKY DIODE; SMT (SOT-23); PIV=30V; IF=0.2A
16	D7	-	1	CMDSH05-4	CENTRAL SEMICONDUCTOR CORP	CMDSH05-4		DIODE; SCH; SURFACE MOUNT LOW VF SILICON SCHOTTKY DIODE; SMT (SOD-323); PIV=40V; IF=0.5A
17	DS1	-	1	LTST-C170GKT	LITE-ON ELECTRONICS INC	LTST-C170GKT		DIODE; LED; STANDARD; GREEN; SMT (0805); PIV=2.1V; IF=0.01A
18	DS2, DS3	-	2	LTST-C170EKT	LITE-ON ELECTRONICS INC	LTST-C170EKT		DIODE; LED; STANDARD; RED; SMT (0805); PIV=2.0V; IF=0.02A
19	J1-J3, J6, J7, J9-J11, J13, J17	-	10	PBC02SAAN	SULLINS ELECTRONICS CORP.	PBC02SAAN		EVKIT PART-CONNECTOR; MALE; THROUGH HOLE; BREAKAWAY; STRAIGHT; 2PINS; -65 DEGC TO +125 DEGC;
20	J4, J5, J8, J12	-	4	PEC03SAAN	SULLINS ELECTRONICS CORP.	PEC03SAAN		EVKIT PART-CONNECTOR; MALE; THROUGH HOLE; BREAKAWAY; STRAIGHT; 3PINS; -65 DEGC TO +125 DEGC;
21	J14	-	1	803-87-020-20-001101	PRECI-DIP SA	803-87-020-20-001101		EVKIT PART-CONNECTOR; FEMALE; TH; DOUBLE ROW; 2.54MM; RIGHT ANGLE SOLDER TAIL; MATING PIN DIA 0.76MM; RIGHT ANGLE; 20PINS;
22	J15	-	1	61301021121	WURTH ELECTRONICS INC	61301021121		CONNECTOR; MALE; THROUGH HOLE; 2.54 DUAL PIN HEADER; STRAIGHT; 10PINS
23	J16	-	1	DF11-6DP-2DSA(24)	HIROSE ELECTRIC CO LTD	DF11-6DP-2DSA(24)		CONNECTOR; MALE; THROUGH HOLE; DF11 SERIES; DOUBLE-ROW CONNECTOR; STRAIGHT; 6PINS;
24	L1	-	1	ETQ-P3M1R0YFN	PANASONIC	1UH		INDUCTOR; SMT; COMPOSITE; 1UH; 20%; 10.7A
25	L2	-	1	LQH32CN220K23	MURATA	22UH		INDUCTOR; 1210; 22UH; +/-10%; 0.25A; -40DEGC TO +85DEGC
26	L3, L4	-	2	74437324022	WURTH ELECTRONICS INC	2.2UH		INDUCTOR; SMT; SHIELDED; 2.2UH; 20%; 3.25A
27	MH1-MH4	-	4	91772A108; PHILLIPS-PAN-4-40X3/8IN; PMSSS4400038PH; 9901	GENERIC PART	N/A		MACHINE SCREW; PHILLIPS; PAN; 4-40; 3/8IN; 18-8 STAINLESS STEEL;
28	MH1-MH4	-	4	MCH_SO_F_HEX_4-40X1/2	GENERIC PART	N/A		STANDOFF; FEMALE-THREADED; HEX; 4-40; 1/2IN; ALUMINUM
29	Q1	-	1	BCP5516TA	DIODES INCORPORATED	BCP5516TA		TRAN; NPN MEDIUM POWER TRANSISTOR; NPN; SOT-223; PD-(2W); I-(1A); V-(60V)
30	Q2	-	1	IRLML6346	INTERNATIONAL RECTIFIER	IRLML6346		TRAN; HEXFET POWER MOSFET; NCH; SOT-23; PD-(1.3W); I-(0.00025A); V-(30V)

MAX25221 Evaluation Kit/
MAX25221 Evaluation System

Evaluates: MAX25220, MAX25221

MAX25221 Frequency Switch (FSW) 2.1Mhz EV Kit Bill of Materials (continued)

The table below refers only to MAX25221 FSW 2.1MHz. For MAX25221 FSW 420kHz and MAX25220 see the dedicated tables to follow.

ITEM	REF_DES	DNI/DNP	QTY	MFG PART #	MANUFACTURER	VALUE	DESCRIPTION	COMMENTS
31	Q3	-	1	BSS84	FAIRCHILD SEMICONDUCTOR	BSS84	ENHANCEMENT MODE FIELD EFFECT TRANSISTOR, P-CHANNEL, SOT-23, PD=0.38W, ID=-0.13A, VDSS=-50V, -55degC TO +150degC	
32	R1, R2, R26	-	3	CR0603-FX-1001ELF	BOURNS	1K	RESISTOR; 0603; 1K OHM; 1%; 100PPM; 0.10W; THICK FILM	
33	R3	-	1	CRCW06033K40FK	VISHAY DALE	3.4K	RESISTOR; 0603; 3.4K OHM; 1%; 100PPM; 0.10W; THICK FILM	
34	R4, R6	-	2	CRCW06031K50FK	VISHAY DALE	1.5K	RESISTOR; 0603; 1.5K; 1%; 100PPM; 0.10W; THICK FILM	
35	R5	-	1	CHPHT0603K1002FGT	VISHAY SFERNICE	10K	RESISTOR; 0603; 10K OHM; 1%; 100PPM; 0.0125W; THICK FILM	
36	R7	-	1	CRCW0603330RFF	VISHAY DALE	330	RESISTOR; 0603; 330 OHM; 1%; 100PPM; 0.10W; THICK FILM	
37	R8, R14	-	2	RC1608J000CS;CR0603-J/-000ELF;RC0603JR-070RL	SAMSUNG ELECTRONICS;BOURNS; YAGEO PH	0	RESISTOR; 0603; 0 OHM; 5%; JUMPER; 0.10W; THICK FILM	
38	R10	-	1	ERJ-3GEYJ242	PANASONIC	2.4K	RESISTOR; 0603; 2.4K OHM; 5%; 200PPM; 0.10W; THICK FILM	
39	R12	-	1	CRCW06031K00FK; ERJ-3EKF1001	VISHAY DALE;PANASONIC	1K	RESISTOR; 0603; 1K; 1%; 100PPM; 0.10W; THICK FILM	
40	R19	-	1	ANY	ANY	0	RESISTOR; 0603; 0 OHM; 0%; JUMPER; 0.10W; THICK FILM; FORMFACTOR	
41	R21, R22	-	2	CRCW0603100KFK; RC0603FR-07100KL; RC0603FR-13100KL; ERJ-3EKF1003; AC0603FR-07100KL	VISHAY DALE;YAGEO;YAGEO; PANASONIC	100K	RESISTOR; 0603; 100K; 1%; 100PPM; 0.10W; THICK FILM	
42	R23	-	1	CRCW0603510KFK	VISHAY DALE	510K	RESISTOR; 0603; 510K; 1%; 100PPM; 0.10W; THICK FILM	
43	R24	-	1	CRCW060386K6FK	VISHAY DALE	86.6K	RESISTOR; 0603; 86.6K OHM; 1%; 100PPM; 0.10W; THICK FILM	
44	R25	-	1	CRCW060310K0FK; ERJ-3EKF1002	VISHAY DALE;PANASONIC	10K	RESISTOR; 0603; 10K; 1%; 100PPM; 0.10W; THICK FILM	
45	RT1	-	1	NCU18XH103F6S	MURATA	10K	THERMISTOR; SMT (0603); 10K; TOL=+/-1%	
46	TP_GND1, TP_GND2	-	2	5006	KEYSTONE	N/A	TEST POINT; PIN DIA=0.125IN; TOTAL LENGTH=0.35IN; BOARD HOLE=0.063IN; BLACK; PHOSPHOR BRONZE WIRE SILVER PLATE FINISH;	
47	U1	-	1	MAX25221ATJ/V+	MAXIM	MAX25221ATJ/V+	EVKIT PART - IC; AUTOMOTIVE 4-CHANNEL TFT-LCD POWER SUPPLY WITH VCOM; PACKAGE OUTLINE DRAWING 21-0140; LAND PATTERN DRAWING: 90-0603; PACKAGE CODE: T3255-6C; TQFN32-EP	
48	U2	-	1	MAX8571EUT+	MAXIM	MAX8571EUT+	IC; CONN; HIGH-EFFICIENCY LCD BOOST WITH TRUE SHUTDOWN; SOT23-6	
49	PCB	-	1	MAX25221	MAXIM	PCB	PCB:MAX25221	-
50	C15, C16, C48, C49	DNP	0	0603YC101KAT2A	AVX	100PF	CAPACITOR; SMT (0603); CERAMIC CHIP; 100PF; 16V; TOL=10%; TG=-55 DEGC TO +125 DEGC; TC=X7R	
51	C17	DNP	0	C0603C103K5RAC; GRM188R71H103K; C0603X7R500-103KNE; C1608X7R1H103K080AE	KEMET;MURATA;VENKEL LTD.;TDK	0.01UF	CAPACITOR; SMT; 0603; CERAMIC; 0.01uF; 50V; 10%; X7R; -55degC to + 125degC	
52	C20, C41, C42	DNP	0	GRM188R71E105KA12; CGA3E1X7R1E105K; TMK107B7105KA; 06033C105KAT2A; GCM188R71E105KA64; C1608X7R1E105K080AE; CGA3E1X7R1E105K080AC	MURATA;TDK;TAIYO YUDEN;AVX; MURATA;TAIYO YUDEN;TDK	1UF	CAPACITOR; SMT (0603); CERAMIC CHIP; 1UF; 25V; TOL=10%; TG=-55 DEGC TO +125 DEGC; TC=X7R	
53	C28	DNP	0	GRM188R61H225KE11	MURATA	2.2UF	CAPACITOR; SMT (0603); CERAMIC CHIP; 2.2UF; 50V; TOL=10%; TG=-55 DEGC TO +85 DEGC; TC=X5R	
54	C32	DNP	0	CC0603KRX7R0BB104; GRM188R72A104KA35; HMK107B7104KA; 06031C104KAT2A; GRM188R72A104K	YAGEO;MURATA;TAIYO YUDEN; AVX;MURATA	0.1UF	CAPACITOR; SMT (0603); CERAMIC CHIP; 0.1UF; 100V; TOL=10%; TG=-55 DEGC TO +125 DEGC; TC=X7R	
55	C43-C46	DNP	0	C1210C106M3RAC; GRM32DR71E106M; C3225X7R1E106M250AC	KEMET;MURATA;TDK	10UF	CAPACITOR; SMT (1210); CERAMIC CHIP; 10UF; 25V; TOL=20%; MODEL=; TG=-55 DEGC TO +125 DEGC; TC=X7R;	
56	R9, R11, R18	DNP	0	RC1608J000CS; CR0603-J/-000ELF; RC0603JR-070RL	SAMSUNG ELECTRONICS;BOURNS; YAGEO PH	0	RESISTOR; 0603; 0 OHM; 5%; JUMPER; 0.10W; THICK FILM	
57	R15, R16, R27, R28	DNP	0	CRCW060310R0FK; MCR03E2PFX10R0; ERJ-3EKF10R0	VISHAY DALE;ROHM	10	RESISTOR; 0603; 10 OHM; 1%; 100PPM; 0.10W; THICK FILM	
58	R17	DNP	0	CHPHT0603K1002FGT	VISHAY SFERNICE	10K	RESISTOR; 0603; 10K OHM; 1%; 100PPM; 0.0125W; THICK FILM	
59	R20	DNP	0	N/A	N/A	0	RESISTOR; 0603; 0 OHM; 0%; JUMPER; 0.10W; THICK FILM; FORMFACTOR	
TOTAL			128					

Note: DNI—DO NOT INSTALL (PACKOUT); DNP—DO NOT PROCURE.

MAX25221 Frequency Switch 420Khz EV Kit Bill of Materials

The table below refers only to MAX25221 FSW 420kHz.

REF_DES	QTY	VALUE	DNI/DNP*	DESCRIPTION	MFG PART #	MFG
C6, C8, C34, C36	4	100000PF	-	CAPACITOR; SMT (0603); CERAMIC CHIP; 100000PF; 100V; TOL=10%; TG=-55 DEGC TO +125 DEGC; TC=X7R	GRM188R72A104KA35D	MURATA
C43-C44	2	10UF	DNP	CAPACITOR; SMT (1210); CERAMIC CHIP; 10UF; 25V; TOL=20%; MODEL=; TG=-55 DEGC TO +125 DEGC; TC=X7R;	C1210C106M3RAC; GRM32DR71E106M; C3225X7R1E106M250AC	KEMET
L3, L4	2	10UH	-	INDUCTOR; SMT; SHIELDED; 10UH; 20%; 3.25A	74437346100	WURTH ELECTRONICS INC

Note: DNI—DO NOT INSTALL (PACKOUT); DNP—DO NOT PROCURE.

MAX25221 Evaluation Kit/
MAX25221 Evaluation System

Evaluates: MAX25220, MAX25221

MAX25220 EV Kit Bill of Materials

For the MAX25220 EV kit refer to the MAX25221 EV kit Bill of Materials and make the necessary changes from the table below.

REF_DES	QTY	VALUE	DNI/DNP*	DESCRIPTION	MFG PART #	MFG
C18	1	0.01UF	DNI	CAPACITOR; SMT; 0603; CERAMIC; 0.01uF; 50V; 10%; X7R; -55degC to + 125degC	C0603C103K5RAC. GRM188R71H103K. C0603X7R500-103KNE. C1608X7R1H103K080AE	KEMET. MURATA. VENKEL LTD. TDK
C21	1	1UF	DNI	CAPACITOR; SMT (0603); CERAMIC CHIP; 1UF; 25V; TOL=10%; TG=-55 DEGC TO +125 DEGC; TC=X7R	GRM188R71E105KA12. CGA3E1X7R1E105K. TMK107B7105KA. 06033C105KAT2A. GCM188R71E105KA64. C1608X7R1E105K080AE. CGA3E1X7R1E105K080AC	MURATA. TDK. TAIYO YUDEN. AVX. MURATA. TAIYO YUDEN. TDK
C52	1	0.1UF	DNI	CAPACITOR; SMT (0603); CERAMIC CHIP; 0.1UF; 100V; TOL=10%; TG=-55 DEGC TO +125 DEGC; TC=X7R	CC0603KRX7R0BB104 GRM188R72A104KA35. GCJ188R72A104KA01. HMK107B7104KA. 06031C104KAT2A	YAGEO MURATA. MURATA. TAIYO YUDEN. AVX
Q1	1	BCP5516TA	DNI-	TRAN; NPN MEDIUM POWER TRANSISTOR; NPN; SOT-223; PD-(2W); I-(1A); V-(60V)	BCP5516TA	DIODES INCORPORATED
R7	1	330	DNI	RESISTOR; 0603; 330 OHMS; 1%; 100PPM; 0.10W; THICK FILM	CRCW0603330RFB	VISHAY DALE
R8, R14	2	0	DNI	RESISTOR; 0603; 0 OHM; 5%; JUMPER; 0.10W; THICK FILM	RC1608J000CS. CR0603-J/-000ELF. RC0603JR-070RL	SAMSUNG ELECTRONICS. BOURNS. YAGEO PH
R10	1	2.4K	DNI	RESISTOR; 0603; 2.4K OHM; 5%; 200PPM; 0.10W; THICK FILM	ERJ-3GEYJ242	PANASONIC
R12	1	1K	DNI	RESISTOR; 0603; 1K; 1%; 100PPM; 0.10W; THICK FILM	CRCW06031K00FK. ERJ-3EKF1001	VISHAY DALE. PANASONIC.
RT1	1	10K	DNI	THERMISTOR; SMT (0603); 10K; TOL=+/-1%	NCU18XH103F6S	MURATA.
U1	1	MAX252210TJV+	-	EVKIT PART - IC; AUTOMOTIVE 4-CHANNEL TFT-LCD POWER SUPPLY WITHVOUT COM; PACKAGE OUTLINE DRAWING: 21-0140; LAND PATTERN DRAWING: 90-0121; TQFN32-EP	MAX25220ATJV+	MAXIM

Note: DNI—DO NOT INSTALL (PACKOUT); DNP—DO NOT PROCURE.

MAX25221 EV Kit Schematic

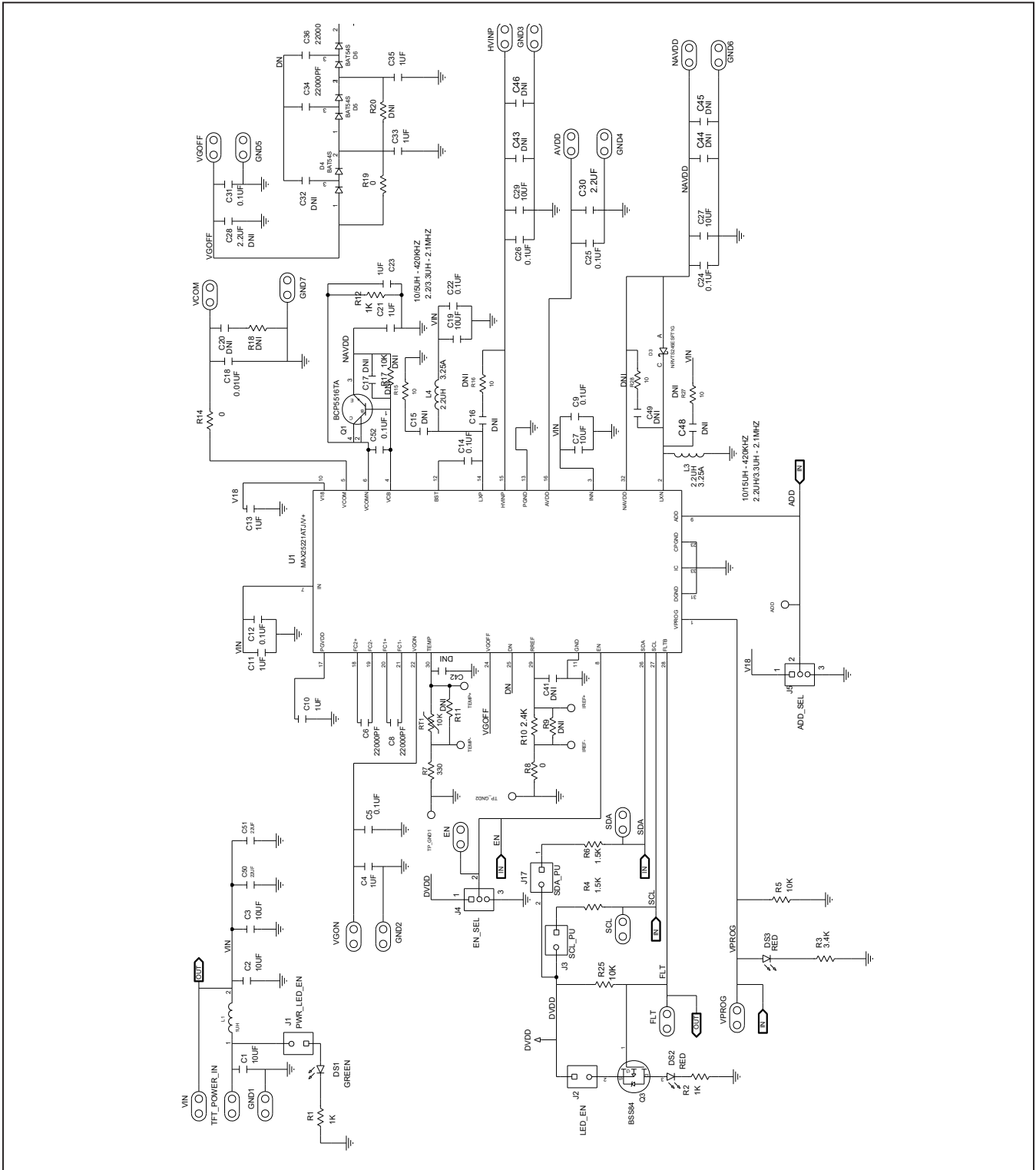

Figure 2. MAX25221 EV Kit Schematic 1-2

MAX25221 EV Kit Schematic (continued)

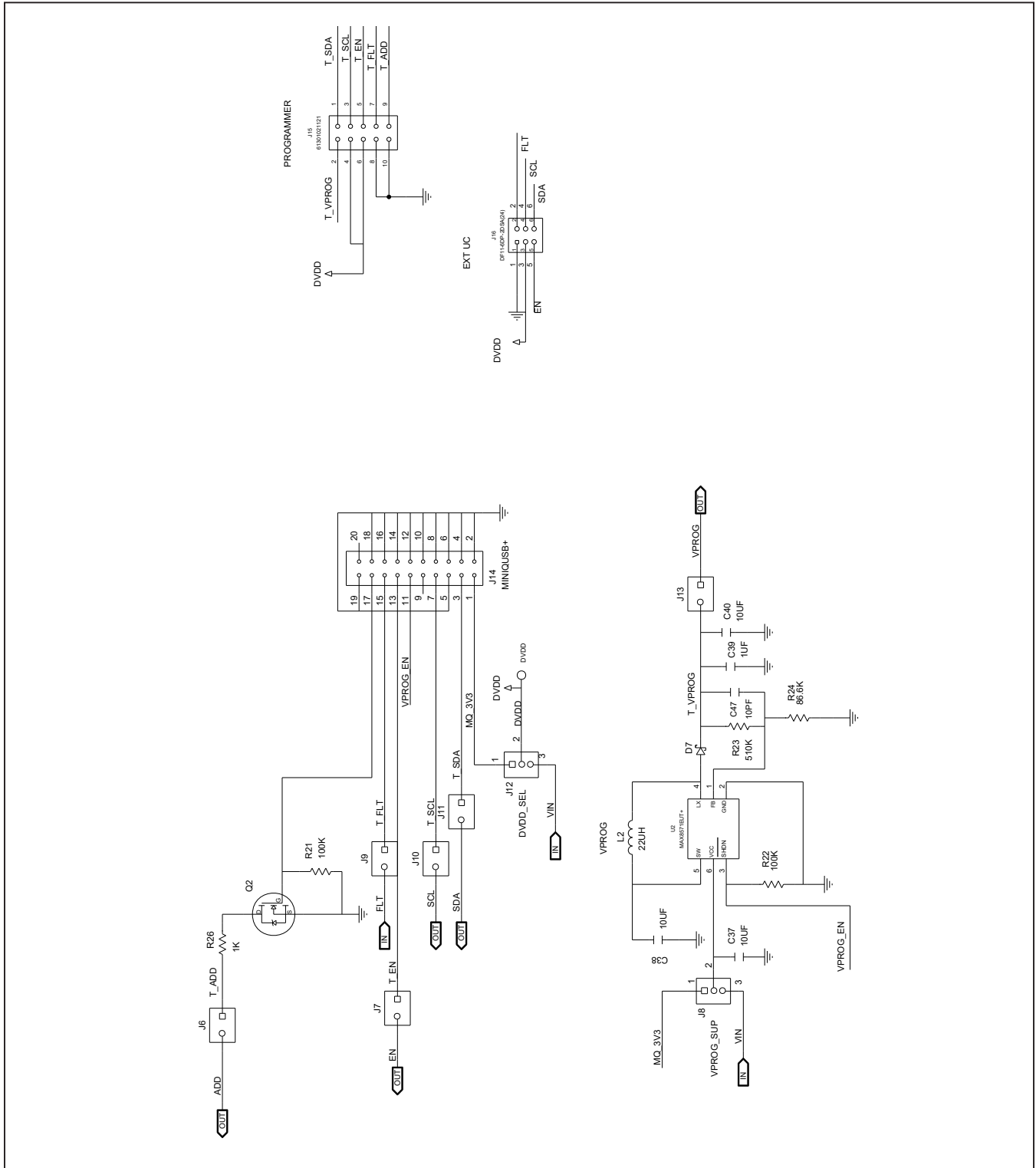
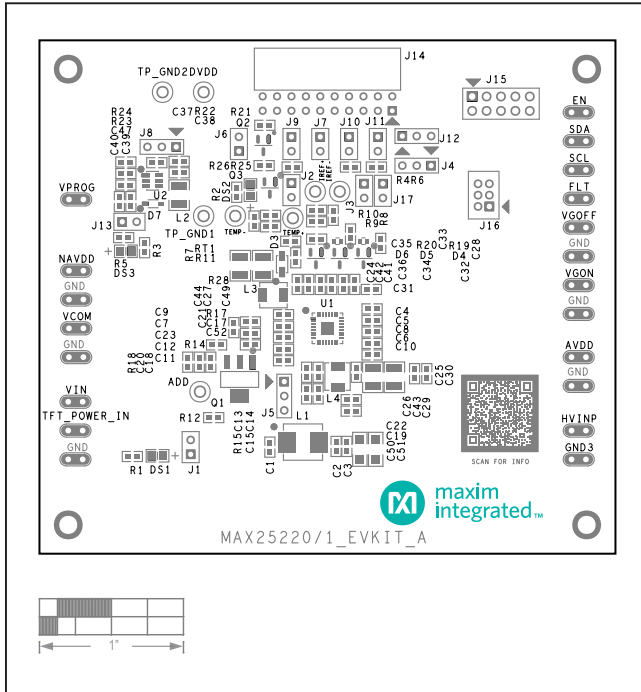

Figure 3. MAX25221 EV Kit Schematic 2-2

MAX25221 Evaluation Kit/
MAX25221 Evaluation System

Evaluates: MAX25220, MAX25221

MAX25221 EV Kit PCB Layouts



MAX25221 EV Kit Component Placement Guide—Top Silkscreen

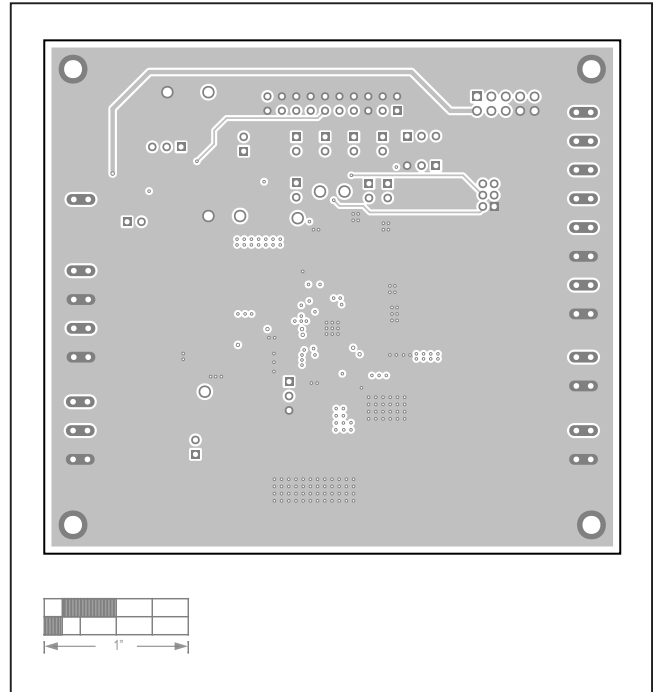

MAX25221 EV Kit PCB Layout—Internal Layer2

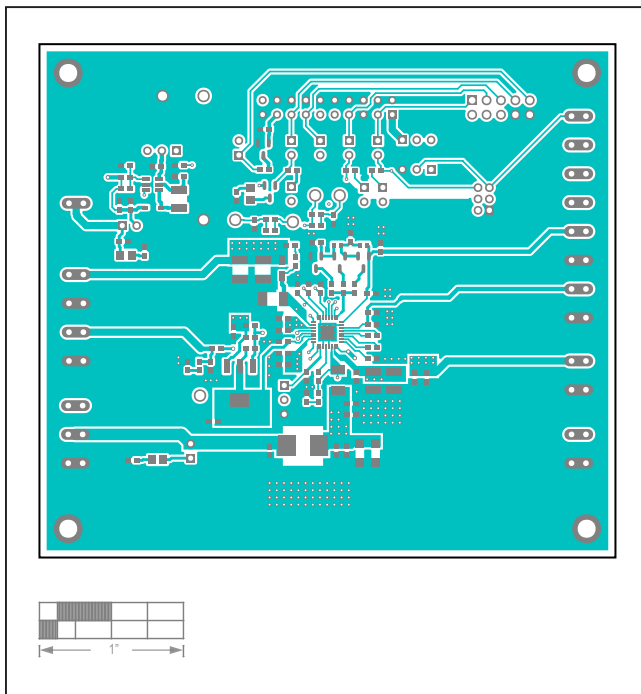

MAX25221 EV Kit PCB Layout—Top Layer+

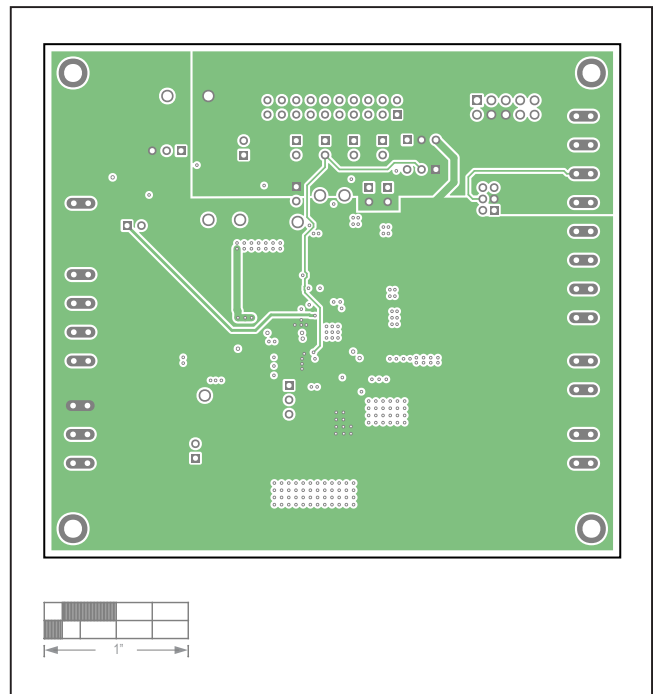

MAX25221 EV Kit PCB Layout—Internal Layer3

MAX25221 EV Kit PCB Layouts (continued)

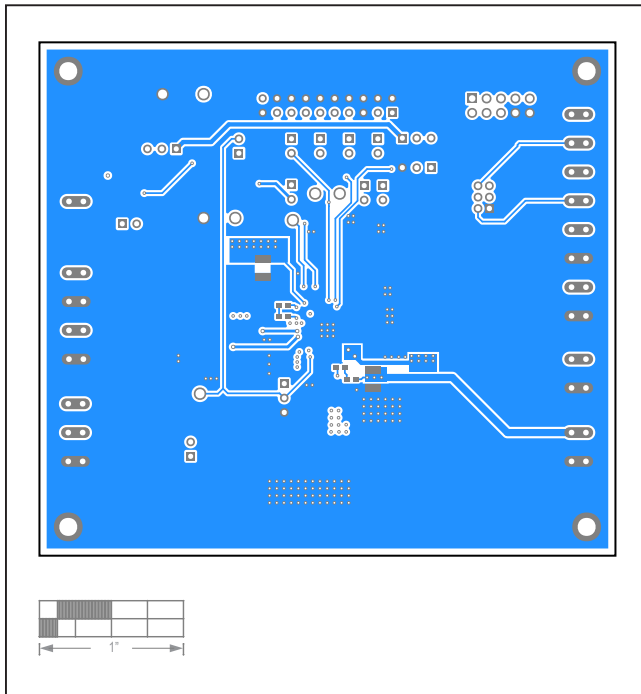

MAX25221 EV Kit PCB Layout—Bottom Layer

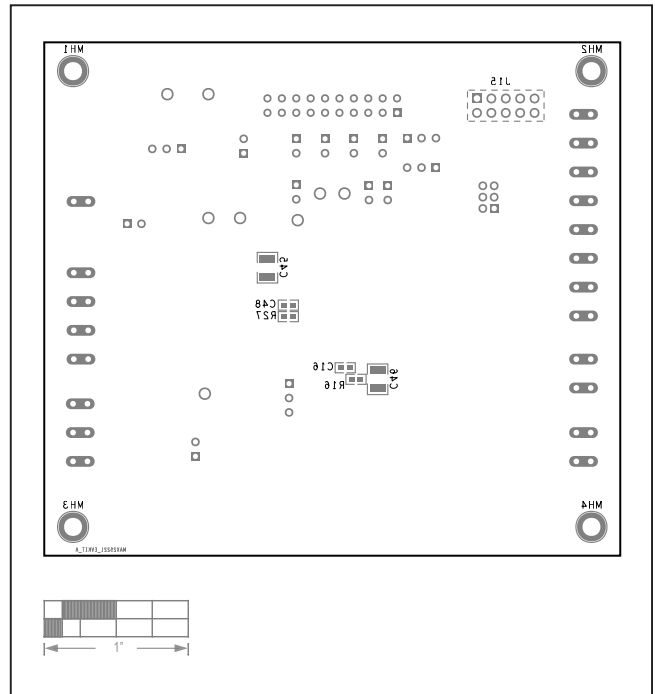

MAX25221 EV Kit PCB Layout—Bottom Components

MAX25221 Evaluation Kit/
MAX25221 Evaluation System

Evaluates: MAX25220, MAX25221

Revision History

REVISION NUMBER	REVISION DATE	DESCRIPTION	PAGES CHANGED
0	6/20	Initial release	—

For pricing, delivery, and ordering information, please visit Maxim Integrated's online storefront at <https://www.maximintegrated.com/en/storefront/storefront.html>.

Maxim Integrated cannot assume responsibility for use of any circuitry other than circuitry entirely embodied in a Maxim Integrated product. No circuit patent licenses are implied. Maxim Integrated reserves the right to change the circuitry and specifications without notice at any time.

X-ON Electronics

Largest Supplier of Electrical and Electronic Components

Click to view similar products for [Display Development Tools](#) category:

Click to view products by [Maxim](#) manufacturer:

Other Similar products are found below :

[KIT 60121-3](#) [S5U13U11P00C100](#) [MAX14521EEVKIT](#) [121CBL02-RPK](#) [KIT 60145-3](#) [S5U13748P00C100](#) [DFR0413](#) [3248](#)
[DLPLCR90EVM](#) [DLPLCR50XEVM](#) [MAX20069EVKIT#](#) [KIT95000-3](#) [LCD-16396](#) [PIM370](#) [1109](#) [MCIMX-LVDS1](#) [MIKROE-2449](#)
[MIKROE-2453](#) [131](#) [DEV-13628](#) [1590](#) [MIKROE-2269](#) [1601](#) [1770](#) [1947](#) [1983](#) [1987](#) [2050](#) [2218](#) [2219](#) [2260](#) [2345](#) [2418](#) [2423](#) [2454](#) [2455](#)
[2478](#) [2674](#) [SK-220RD-PI](#) [FIT0477](#) [333](#) [334](#) [TE-M321-SDK](#) [DFR0428](#) [cs-epapersk-03](#) [338](#) [DEV-14442](#) [FIT0478](#) [cs-paperino-01](#) [OM-E-OLE](#)