

MAX25231

36V, 1.2A Mini Buck Converter with 3.5 μ A I_Q

General Description

The MAX25231 is a small, synchronous automotive buck converter with integrated high-side and low-side switches. The MAX25231 is designed to deliver up to 1.2A, with 3.5V to 36V input voltages, while using only 3.5 μ A quiescent current at no load. The device provides an accurate output voltage of $\pm 2\%$ within the normal operation input range of 6V to 18V. With 65ns minimum on-time capability, the converter is capable of large input-to-output conversion ratios. Voltage quality can be monitored by observing the PGOOD signal. The device can operate in dropout by running at 99% duty cycle, making it ideal for automotive and industrial applications. The device offers two fixed output voltages of 5V and 3.3V. Frequency is internally fixed at 2.1MHz, which allows for small external components and reduced output ripple, and guarantees no AM interference. The device automatically enters skip mode at light loads with ultra-low quiescent current of 3.5 μ A at no load. The device offers pin-enabled spread-spectrum frequency modulation designed to minimize EMI-radiated emissions due to the modulation frequency.

The MAX25231 is available in a small (3mm x 3mm) 12-pin TDFN package with an exposed pad, and uses very few external components.

Applications

- Automotive
- Always-On, Low-Quiescent-Current Systems
- Industrial
- High-Voltage DC-DC Converters

Benefits and Features

- Synchronous DC-DC Converter with Integrated FETs
 - 3.5 μ A Quiescent Current when in Standby Mode
- Small Solution Size Saves Space
 - 2.1MHz Frequency
 - Fixed 5V/3.3V Output Voltage Options Available
 - Fixed 2.5ms Internal Soft-Start
 - Fixed Output Voltage with $\pm 2\%$ Output Accuracy
 - Adjustable Voltage Output 3V to 10V Available (MAX25231ATCD)
 - Innovative Current-Mode-Control Architecture Minimizes Total Board Space and BOM Count
- PGOOD Output and High-Voltage EN Input Simplify Power Sequencing
- Protection Features and Operating Range Ideal for Automotive Applications
 - 3.5V to 36V Operating VIN Range
 - 40V Load-Dump Protection
 - 99% Duty-Cycle Operation with Low Dropout
 - -40°C to $+125^{\circ}\text{C}$ Automotive Temperature Range
 - AEC-Q100 Qualified

Ordering Information appears at end of data sheet.

Simplified Block Diagram

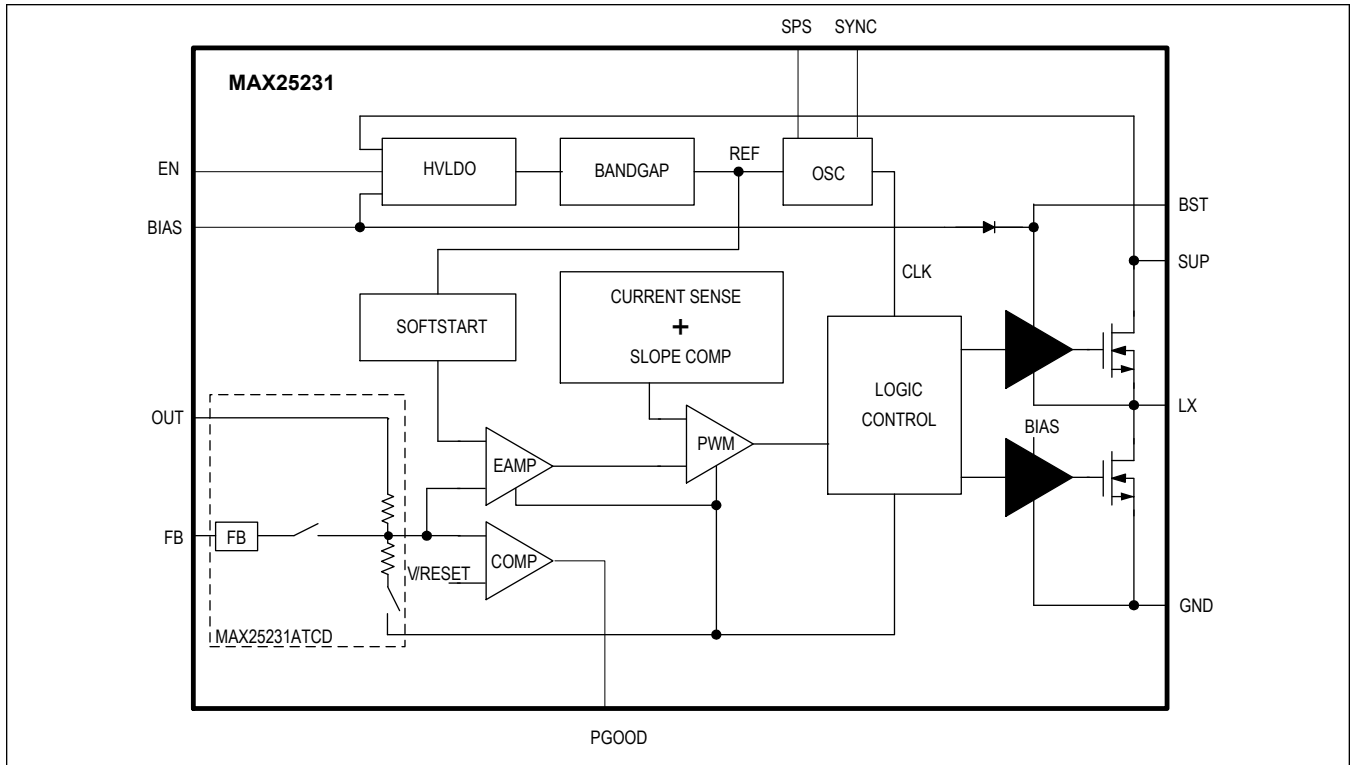

Absolute Maximum Ratings

SUP	-0.3V to +40V	OUT Short-Circuit Duration	Continuous
EN	-0.3V to V _{SUP} + 0.3V	ESD Protection	
BST to LX (Note 1)	+6V	Human Body Model	±2kV
BST	-0.3V to +45V	Continuous Power Dissipation (T _A = +70°C)	
FB	-0.3V to V _{BIAS} + 0.3V	12-pin TDFN/SW TDFN	
SYNC	-0.3V to V _{BIAS} + 0.3V	(derate 24.4mW/°C above +70°C)	1951mW
SPS	-0.3V to V _{BIAS} + 0.3V	Operating Junction Temperature (Note 4)	-40°C to +150°C
OUT	-0.3V to +12V	Storage Temperature Range	-65°C to +150°C
OUT (MAX25231AFOD)	-0.3V to +12V	Junction Temperature	+150°C
PGOOD	-0.3V to +6V	Lead Temperature (Soldering, 10s)	+300°C
PGND to AGND	-0.3V to +0.3V	Soldering Temperature (Reflow)	+260°C
BIAS	-0.3V to +6V		

Note 1: LX has internal clamp diodes to PGND/AGND and SUP. Applications that forward bias these diodes should take care not to exceed the IC’s package power-dissipation limits.

Stresses beyond those listed under “Absolute Maximum Ratings” may cause permanent damage to the device. These are stress ratings only, and functional operation of the device at these or any other conditions beyond those indicated in the operational sections of the specifications is not implied. Exposure to absolute maximum rating conditions for extended periods may affect device reliability.

Package Information

12 TDFN-CU

Package Code	TD1233+2C
Outline Number	21-0664
Land Pattern Number	90-0397
THERMAL RESISTANCE, FOUR-LAYER BOARD	
Junction-to-Ambient (θ _{JA})	41°C/W
Junction-to-Case Thermal Resistance (θ _{JC})	8.5°C/W

For the latest package outline information and land patterns (footprints), go to www.maximintegrated.com/packages. Note that a “+”, “#”, or “-” in the package code indicates RoHS status only. Package drawings may show a different suffix character, but the drawing pertains to the package regardless of RoHS status.

Package thermal resistances were obtained using the method described in JEDEC specification JESD51-7, using a four-layer board. For detailed information on package thermal considerations, refer to www.maximintegrated.com/thermal-tutorial.

Electrical Characteristics

(V_{SUP} = V_{EN}, V_{SUP} = 14V, V_{SYNC} = 0V, V_{OUT} = 5V, T_J = -40°C to +150°C, unless otherwise noted.) (Notes 3, 4)

PARAMETER	SYMBOL	CONDITIONS	MIN	TYP	MAX	UNITS
Supply Voltage Range	V _{SUP}		3.5		36	V
		t < 1s			40	
	V _{SUP}	After soft-start	3		36	

Electrical Characteristics (continued)(V_{SUP} = V_{EN}, V_{SUP} = 14V, V_{SYNC} = 0V, V_{OUT} = 5V, T_J = -40°C to +150°C, unless otherwise noted.) (Notes 3, 4)

PARAMETER	SYMBOL	CONDITIONS	MIN	TYP	MAX	UNITS	
Supply Current	I _{SUP}	V _{EN} = low		1	5	µA	
		MAX25231ATCB/V+, no load, no switching		3.5	8		
		MAX25231ATCB/V+, no load, switching (Note 2)		4.5			
		MAX25231ATCA/V+, no load, no switching		5.6	10		
		MAX25231ATCA/V+, no load, switching (Note 2)		6.6			
LX Leakage	I _{LX,LEAK}	V _{SUP} = 40V, L _X = 0 or 40V, T _A = +25°C	-1		+1	µA	
Undervoltage Lockout	UVLO	OUT rising	2.52	2.73	2.93	V	
		Hysteresis		0.16			
BIAS Voltage	V _{BIAS}	5.5V ≤ V _{SUP} ≤ 36V, FPWM mode		5		V	
BUCK CONVERTER							
Voltage Accuracy, 5V	V _{OUT,5V}	MAX25231ATCA/V+ skip mode (Note 2)	4.87	5	5.08	V	
		MAX25231ATCA/V+ fixed-frequency PWM mode	4.93	5	5.07		
Voltage Accuracy, 3.3V	V _{OUT,3.3V}	MAX25231ATCB/V+, skip mode	3.18	3.3	3.37	V	
		MAX25231ATCB/V+, fixed-frequency PWM mode	3.25	3.3	3.35		
Output Voltage Range	V _{OUT}	MAX25231ATCD/V+	3		10	V	
FB Voltage Accuracy	V _{FB}	MAX25231ATCD/V+ only	0.985	1	1.015	V	
FB Current	I _{FB}	V _{FB} = 1V, T _A = +25°C		0.02		µA	
FB Line Regulation		V _{SUP} = 6V to 36V		0.02		%/V	
High-Side Switch On-Resistance	R _{ON,HS}	V _{BIAS} = 5V, I _{LX} = 1.2A		300		mΩ	
Low-Side Switch On-Resistance	R _{ON,LS}	V _{BIAS} = 5V, I _{LX} = 1.2A		200		mΩ	
High-Side Current-Limit Threshold		MAX25231	1.67	1.9	2.13	A	
Low-Side Negative Current- Limit Threshold	I _{NEG}			-0.6		A	
Soft-Start Ramp Time	I _{SS}			2.5	5	ms	
Minimum On-Time	t _{ON}			66	85	ns	
Maximum Duty Cycle			98	99		%	
PWM Switching Frequency	f _{SW}	Fixed	1.925	2.1	2.275	MHz	
Spread-Spectrum Range	SS	V _{SPS} = 5V		±6		%	
PGOOD							
PGOOD Threshold, Rising	V _{THR,PGD}	V _{OUT} rising	MAX25231ATCA/V+	90	93.5	97	%

Electrical Characteristics (continued)(V_{SUP} = V_{EN}, V_{SUP} = 14V, V_{SYNC} = 0V, V_{OUT} = 5V, T_J = -40°C to +150°C, unless otherwise noted.) (Notes 3, 4)

PARAMETER	SYMBOL	CONDITIONS		MIN	TYP	MAX	UNITS
PGOOD Threshold, Falling	V _{THF,PGD}	V _{OUT} falling	MAX25231ATCA/ V+	89.5	93	96.5	%
PGOOD Debounce Time	t _{DEB}	PWM mode, V _{OUT} falling		65			μ s
		Skip mode, V _{OUT} rising		100			
PGOOD High-Leakage Current	I _{LEAK,PGD}	T _A = +25°C				1	μ A
PGOOD Low Level	V _{OUT,PGD}	Sinking 1mA				0.4	V
LOGIC LEVELS							
EN Level, High	V _{IH,EN}			2.4			V
EN Level, Low	V _{IL,EN}					0.6	V
EN Input Current	I _{IN,EN}	V _{EN} = V _{SUP} = 14V, T _A = +25°C				1	μ A
External Input Clock Frequency				1.7		2.6	MHz
SYNC Threshold, High	V _{IH,SYNC}			1.4			V
SYNC Threshold, Low	V _{IL,SYNC}					0.4	V
SYNC Internal Pulldown	R _{PD,MODE}			1000			k Ω
SPS Threshold, High	V _{IH,SPS}			1.4			V
SPS Threshold, Low	V _{IL,SPS}					0.4	V
SPS Internal Pulldown				1000			k Ω
THERMAL PROTECTION							
Thermal Shutdown	T _{SHDN}	(Note 3)				175	°C
Thermal-Shutdown Hysteresis	T _{SHDN.HYS}	(Note 3)				15	°C

Note 2: Guaranteed by design; not production tested.**Note 3:** Limits are 100% tested at T_A = +25°C. Limits over the operating range and relevant supply voltage are guaranteed by design and characterization. Typical values are at T_A = +25°C.**Note 4:** The device is designed for continuous operation up to T_J = +125°C for 95,000 hours and T_J = +150°C for 5,000 hours.

Typical Operating Characteristics

(V_{SUP} = V_{EN} = +14V, (T_A = +25°C, unless otherwise noted.)

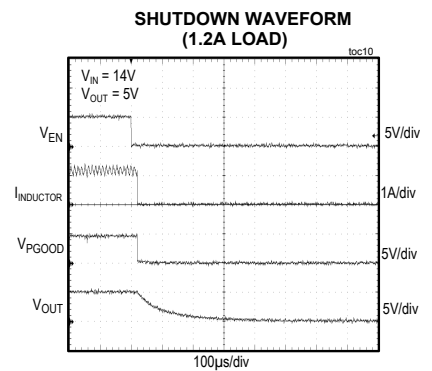
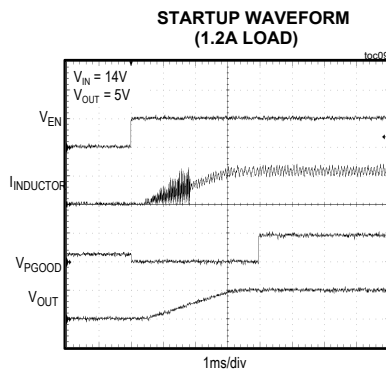
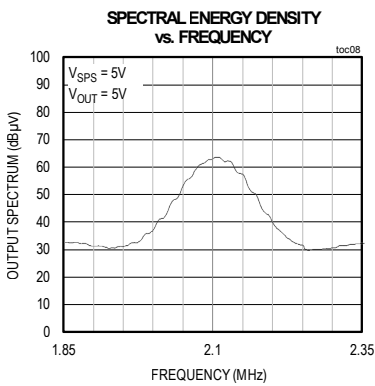
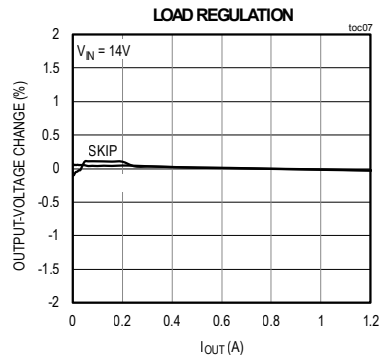
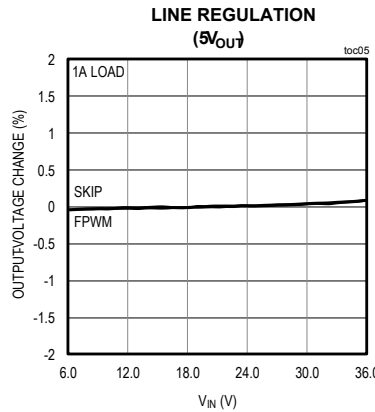
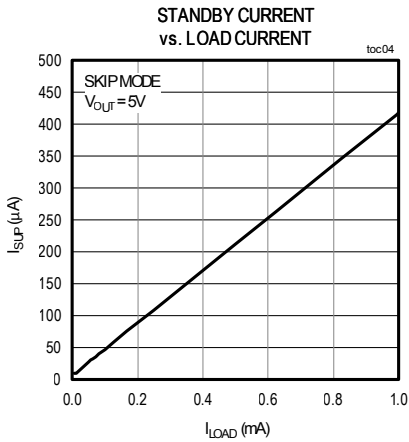
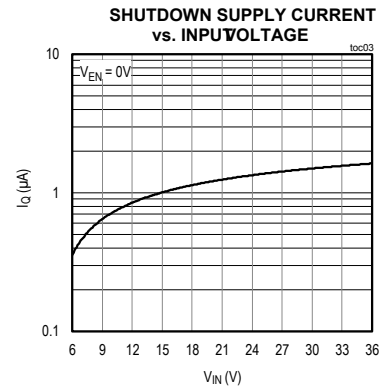
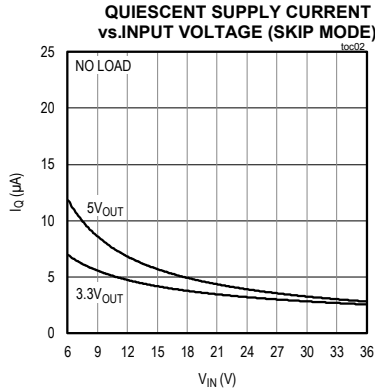
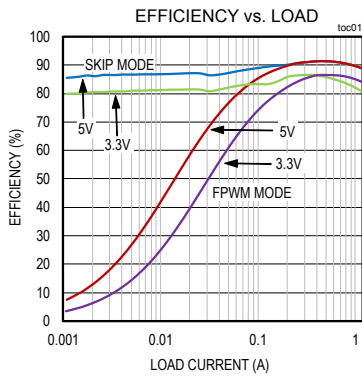

Typical Operating Characteristics (continued)

(V_{SUP} = V_{EN} = +14V, (T_A = +25°C, unless otherwise noted.)

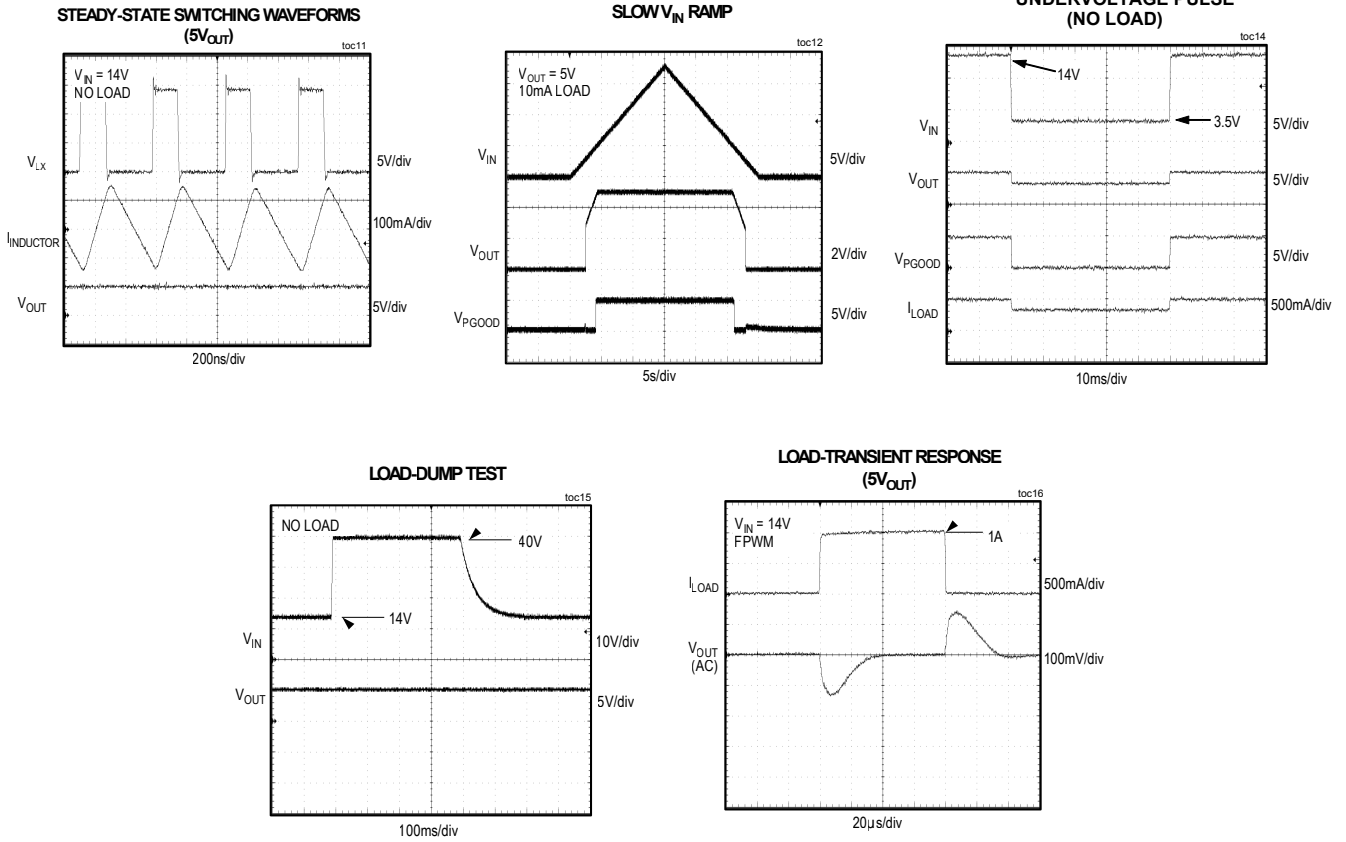

Pin Configuration

MAX25231

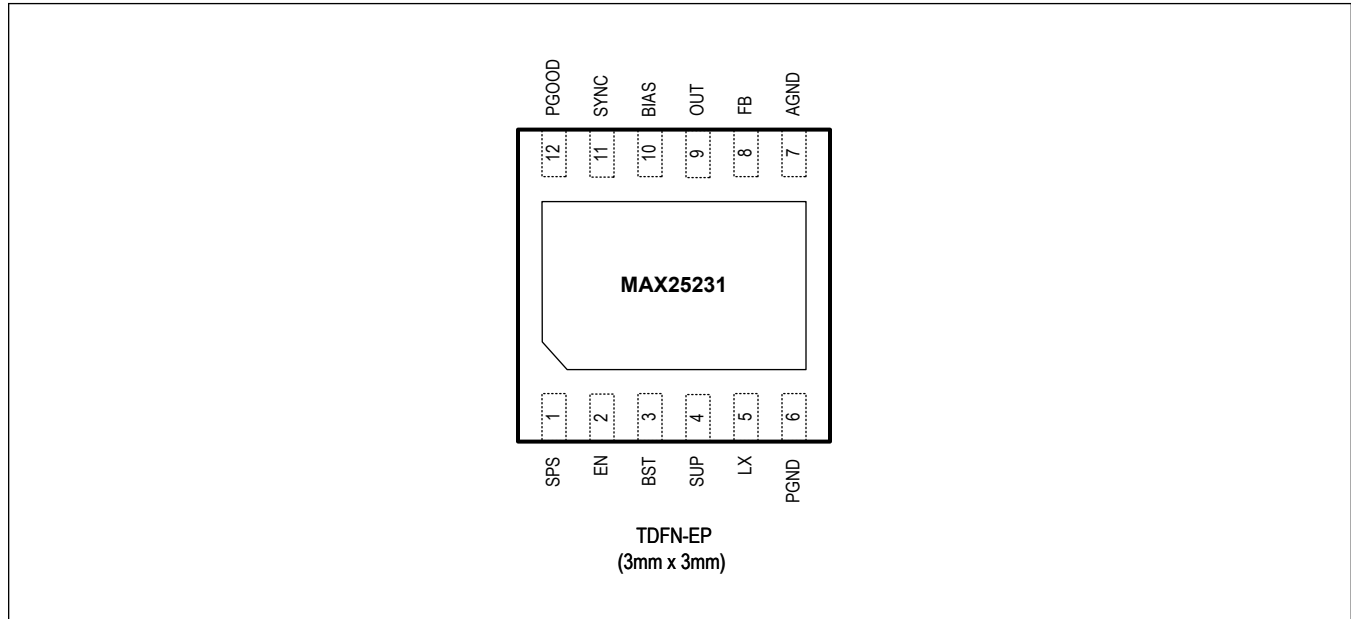

Pin Description

PIN	NAME	FUNCTION
1	SPS	Spread-Spectrum Enable. Connect logic-high to enable spread spectrum of internal oscillator or logic-low to disable spread spectrum. This pin has a 1MΩ internal pulldown.
2	EN	High-Voltage-Compatible Enable Input. If this pin is low, the part is off.
3	BST	Bootstrap Pin for HS Driver. It is recommended to use 0.1µF from BST to LX.
4	SUP	Supply Input. Connect a 4.7µF ceramic capacitor from SUP to PGND.
5	LX	Buck Switching Node. High impedance when part is off. Connect a 4.7µH inductor between LX and OUT.
6	PGND	Power Ground. Ground return path for all high-current/high-frequency noisy signals.
7	AGND	Analog Ground. Ground return path for all 'quiet' signals.
8	FB	Feedback Pin. Connect a resistor-divider from OUT to FB to ground for external adjustment of the output voltage (MAX25231ATCD only). Connect to bias for internal fixed voltage configurations.
9	OUT	Buck Regulator Output-Voltage-Sense Input. Bypass OUT to PGND with 22µF ceramic capacitor.
10	BIAS	5V Internal BIAS Supply. Connect a 1µF (min) ceramic capacitor to AGND.
11	SYNC	Sync Input. If connected to ground or open, skip-mode operation is enabled under light loads; if connected to BIAS, forced-PWM mode is enabled. This pin has a 1MΩ internal pulldown.
12	PGOOD	Open-Drain Reset Output. External pullup required.
-	EP	Exposed Pad. EP must be connected to ground plane on PCB, but is not a current-carrying path and is only needed for thermal transfer.

Detailed Description

The MAX25231 family of small, current-mode-controlled buck converters features synchronous rectification and requires no external compensation network. The devices are designed for 1.2A and can stay in dropout by running at 99% duty cycle. They provide an accurate output voltage within the 5.5V to 18V input range. Voltage quality can be monitored by observing the PGOOD signal. The devices operate at a frequency of 2.1MHz (typ), which allows for small external components, reduced output ripple, and guarantees no AM band interference.

The devices feature an ultra-low 3.5 μ A (typ) quiescent supply current in standby mode. The devices enter standby mode automatically at light loads if HSFET does not turn on for eight consecutive clock cycles. The devices operate from a 3.5V to 36V supply voltage and can tolerate transients up to 40V, making them ideal for automotive applications. The devices are available in factory-trimmed fixed output voltages of 5V and 3.3V and are programmable with an external resistor-divider (MAX25231ATCD only). For fixed output voltages outside of 3.3V and 5V, contact factory for availability.

Enable Input (EN)

The device is activated by driving EN high. EN is compatible from a 3.3V logic level to automotive battery levels. EN can be controlled by microcontrollers and automotive KEY or CAN inhibit signals. The EN input has no internal pullup/pulldown current to minimize the overall quiescent supply current. To realize a programmable undervoltage-lockout level, use a resistor-divider from SUP to EN to AGND.

BIAS/UVLO

The device features undervoltage lockout. When the device is enabled, an internal bias generator turns on. LX begins switching after V_{BIAS} has exceeded the internal undervoltage-lockout level, V_{UVLO} = 2.73V (typ).

Soft-Start

The device features an internal soft-start timer. The output voltage soft-start ramp time is 2.5ms (typ). If a short circuit or undervoltage is encountered after the soft-start timer has expired, the device is disabled for 6ms (typ) and then reattempts soft-start again. This pattern repeats until the short circuit has been removed.

Oscillator/Synchronization and Efficiency (SYNC)

The device has an on-chip oscillator that provides a 2.1MHz (typ) switching frequency. Depending on the condition of SYNC, two operation modes exist. If SYNC is unconnected or at AGND, the device operates in highly efficient pulse-skipping mode. If SYNC is at BIAS or has a clock applied to it, the device is in forced-PWM mode (FPWM). The device can be switched during operation between FPWM mode and skip mode by switching SYNC.

Skip-Mode Operation

Skip mode is entered when the SYNC pin is connected to ground or is unconnected and the peak load current is < 150mA (typ). In this mode, the high-side FET is turned on until the current in the inductor is ramped up to 150mA (typ) peak value and the internal feedback voltage is above the regulation voltage (1.0V, typ). At this point, both the high-side and low-side FETs are turned off. Depending on the choice of the output capacitor and the load current, the high-side FET turns on when OUT (valley) drops below the 1.0V (typ) feedback voltage. For fixed output voltage parts, when the device is in skip mode, the internal high-voltage LDO is turned off after the startup is complete to reduce the input current. V_{BIAS} is supplied by the output in this condition.

Achieving High Efficiency at Light Loads

The device operates with very low quiescent current at light loads to enhance efficiency and conserve battery life. When the device enters skip mode, the output current is monitored to adjust the quiescent current.

When the output current is less than approximately 5mA, the devices operate in the lowest-quiescent-current mode, also called standby mode. In this mode, the majority of the internal circuitry (excluding that necessary to maintain regulation) in the device, including the internal high-voltage LDO, is turned off to save current. Under no load and with skip mode

enabled, the IC typically draws 4.5 μ A for the 3.3V parts, and 6.6 μ A for the 5.0V parts. For load currents greater than 5mA, the device enters normal skip mode, still maintaining very high efficiency.

Controlled EMI with Forced Fixed Frequency

In FPWM mode, the device attempts to operate at a constant switching frequency for all load currents. For tightest frequency control, apply the operating frequency to SYNC. The advantage of this mode is a constant switching frequency, which improves EMI performance; the disadvantage is that considerable current can be wasted. If the load current during a switching cycle is less than the current flowing through the inductor, the excess current is diverted to AGND.

Extended Input Voltage Range

In some cases, the device is forced to deviate from its operating frequency, independent of the state of SYNC. For input voltages above 18V, the required duty cycle to regulate its output may be smaller than the minimum on- time (66ns, typ). In this event, the device is forced to lower its switching frequency by skipping pulses.

If the input voltage is reduced and the device approaches dropout, the device tries to turn on the high-side FET continuously. To maintain gate charge on the high-side FET, the BST capacitor must be periodically recharged. To ensure proper charge on the BST capacitor when in dropout, the high-side FET is turned off every 20 μ s and the low-side FET is turned on for about 200ns. This gives an effective duty cycle of > 99% and a switching frequency of 50kHz when in dropout.

Spread-Spectrum Option

The device has an optional spread spectrum enabled by the SPS pin. If SPS is pulled high, then the internal operating frequency varies by $\pm 6\%$ relative to the internally generated operating frequency of 2.1MHz (typ). Spread spectrum is offered to improve EMI performance of the device.

The internal spread spectrum does not interfere with the external clock applied on the SYNC pin. It is active only when the device is running with an internally generated switching frequency.

Power-Good (PGOOD)

The device features an open-drain power-good output. PGOOD is an active-high output that pulls low when the output voltage is below 93% of its nominal value. PGOOD is high impedance when the output voltage is above 93.5% of its nominal value. Connect a 20k Ω (typ) pullup resistor to an external supply or the on-chip BIAS output.

Overcurrent Protection

The device limits the peak output current to 1.9A (typ). The accuracy of the current limit is $\pm 12\%$, which makes selection of external components very easy. To protect against short-circuit events, the device shuts off when OUT is below 50% of OUT voltage and an overcurrent event is detected. The device attempts a soft-start restart every 7ms and remains off if the short circuit has not been removed. When the current limit is no longer present, it reaches the output voltage by following the normal soft-start sequence. If the device's die reaches the thermal limit of 175 $^{\circ}$ C (typ) during the current-limit event, it immediately shuts off.

Thermal-Overload Protection

The device features thermal-overload protection, turning off when the junction temperature exceeds +175 $^{\circ}$ C (typ). Once the device cools by 15 $^{\circ}$ C (typ), it turns back on with a soft-start sequence.

Applications Information

Setting the Output Voltage

MAX25231ATCA and MAX25231ATCB are configured with a fixed output voltage.

MAX25231ATCD is configured with an adjustable output voltage between 3V and 10V. Connect a resistive divider from output (OUT) to FB to AGND as the following figure. Select R_{FB2} (FB to AGND resistor) less than or equal to 500kΩ. Calculate R_{FB1} (OUT to FB resistor) with the following equation:

$$R_{FB1} = R_{FB2} [(V_{OUT}/V_{FB}) - 1]$$

where V_{FB} = 1V.

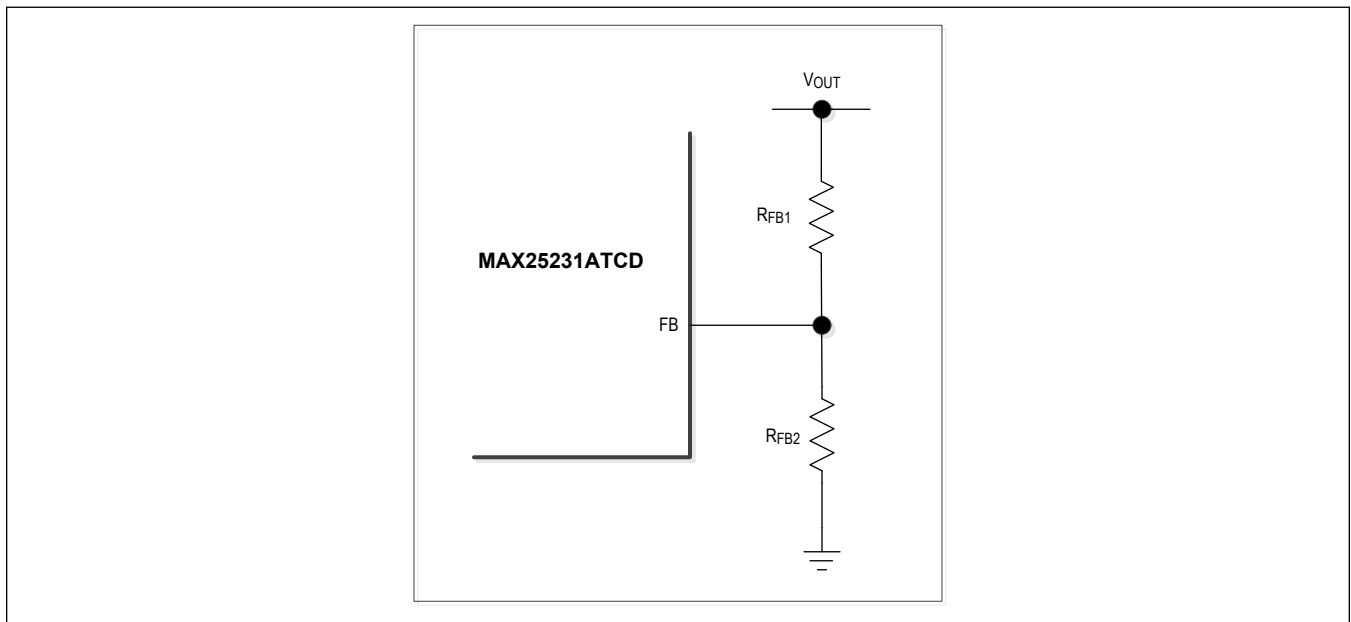

Inductor Selection

The design is optimized with 4.7μH inductor for all input and output voltage conditions. The nominal standard value selected should be within ±50% of 4.7μH.

Input Capacitor

A low-ESR ceramic input capacitor of 4.7μF is recommended for proper device operation. This value can be adjusted based on application input-voltage ripple requirements.

The discontinuous input current of the buck converter causes large input ripple current. The switching frequency, peak inductor current, and the allowable peak-to-peak input-voltage ripple dictate the input-capacitance requirement. Increasing the switching frequency or the inductor value lowers the peak-to-average current ratio, yielding a lower input-capacitance requirement.

The input ripple is primarily composed of ΔV_Q (caused by the capacitor discharge) and ΔV_{ESR} (caused by the ESR of the input capacitor). The total voltage ripple is the sum of ΔV_Q and ΔV_{ESR}. Assume that input-voltage ripple from the ESR and the capacitor discharge is equal to 50% each. The following equations show the ESR and capacitor requirement for a target voltage ripple at the input:

Equation 1:

$$ESR = \frac{\Delta V_{ESR}}{I_{OUT} + (\Delta I_{P-P}/2)}$$

$$C_{IN} = \frac{I_{OUT} \times D(1-D)}{\Delta V_Q \times f_{SW}}$$

where:

$$\Delta I_{P-P} = \frac{(V_{IN} - V_{OUT}) \times V_{OUT}}{V_{IN} \times f_{SW} \times L}$$

and:

$$D = \frac{V_{OUT}}{V_{IN}}$$

where I_{OUT} is the output current, D is the duty cycle, and f_{SW} is the switching frequency. Use additional input capacitance at lower input voltages to avoid possible undershoot below the UVLO threshold during transient loading.

Output Capacitor

For optimal phase margin (> 70 deg, typ) with internal fixed-voltage options, a 22µF output capacitor is recommended. A lower output capacitor can be used at the expense of lower phase margin. For all other designs, a minimum 10µF output capacitor is required. Additional output capacitance may be needed based on application-specific output-voltage ripple requirements. If the total output capacitance required is > 70µF, contact the factory for an optimized solution.

The allowable output-voltage ripple and the maximum deviation of the output voltage during step-load currents determine the output capacitance and its ESR. The output ripple comprises ΔV_Q (caused by the capacitor discharge) and ΔV_{ESR} (caused by the ESR of the output capacitor). Use low-ESR ceramic or aluminum electrolytic capacitors at the output. For aluminum electrolytic capacitors, the entire output ripple is contributed by ΔV_{ESR}. Use the ESR_{OUT} equation to calculate the ESR requirement and choose the capacitor accordingly. If using ceramic capacitors, assume the contribution to the output ripple voltage from the ESR and the capacitor discharge to be equal. The following equations show the output capacitance and ESR requirement for a specified output-voltage ripple.

Equation 2:

$$ESR = \frac{\Delta V_{ESR}}{\Delta I_{P-P}}$$

$$C_{OUT} = \frac{\Delta I_{P-P}}{8 \times \Delta V_Q \times f_{SW}}$$

where:

$$\Delta I_{P-P} = \frac{(V_{IN} - V_{OUT}) \times V_{OUT}}{V_{IN} \times f_{SW} \times L}$$

and:

$$V_{OUT_RIPPLE} = \Delta V_{ESR} + \Delta V_Q$$

ΔI_{P-P} is the peak-to-peak inductor current as calculated above, and f_{SW} is the converter's switching frequency. The allowable deviation of the output voltage during fast transient loads also determines the output capacitance and its ESR. The output capacitor supplies the step-load current until the converter responds with a greater duty cycle. The response time (t_{RESPONSE}) depends on the closed-loop bandwidth of the converter. The high switching frequency of the devices allows for a higher closed-loop bandwidth, thus reducing t_{RESPONSE} and the output-capacitance requirement. The resistive drop across the output capacitor's ESR and the capacitor discharge causes a voltage droop during a step load. Use a combination of low-ESR tantalum and ceramic capacitors for better transient load and ripple/noise performance. Keep the maximum output-voltage deviations below the tolerable limits of the electronics being powered. When using a ceramic capacitor, assume an 80% and 20% contribution from the output-capacitance discharge and the ESR drop, respectively. Use the following equations to calculate the required ESR and capacitance value:

Equation 3:

$$ESR_{OUT} = \frac{\Delta V_{ESR}}{I_{STEP}}$$
$$C_{OUT} = \frac{I_{STEP} \times t_{RESPONSE}}{\Delta V_Q}$$

where I_{STEP} is the load step and t_{RESPONSE} is the response time of the converter. The converter response time depends on the control-loop bandwidth.

PCB Layout Guidelines

Careful PCB layout is critical to achieve low switching power losses and clean, stable operation. Use a multilayer board wherever possible for better noise immunity. Follow the guidelines below for a good PCB layout:

1. The input capacitor (4.7μF, see [Circuit1 - Fixed Output](#) Typical Application Circuit) should be placed right next to the SUP pin. Since the MAX25231 operates at 2.1MHz switching frequency, this placement is critical for effective decoupling of high-frequency noise from the SUP pins.
2. Solder the exposed pad to a large copper-plane area under the device. To effectively use this copper area as a heat exchanger between the PCB and ambient, expose the copper area on the top and bottom side. Add a few small vias or one large via on the copper pad for efficient heat transfer. Connect the exposed pad to PGND, ideally at the return terminal of the output capacitor.
3. Isolate the power components and high-current paths from sensitive analog circuitry.
4. Keep the high-current paths short, especially at the ground terminals. This practice is essential for stable, jitter-free operation.
5. Connect PGND and AGND together, preferably at the return terminal of the output capacitor. Do not connect them anywhere else.
6. Keep the power traces and load connections short. This practice is essential for high efficiency. Use thick copper PCB to enhance full-load efficiency and power-dissipation capability.
7. Route high-speed switching nodes away from sensitive analog areas. Use internal PCB layers as PGND to act as EMI shields to keep radiated noise away from the device and analog bypass capacitor.

Typical Application Circuits

Circuit1 - Fixed Output

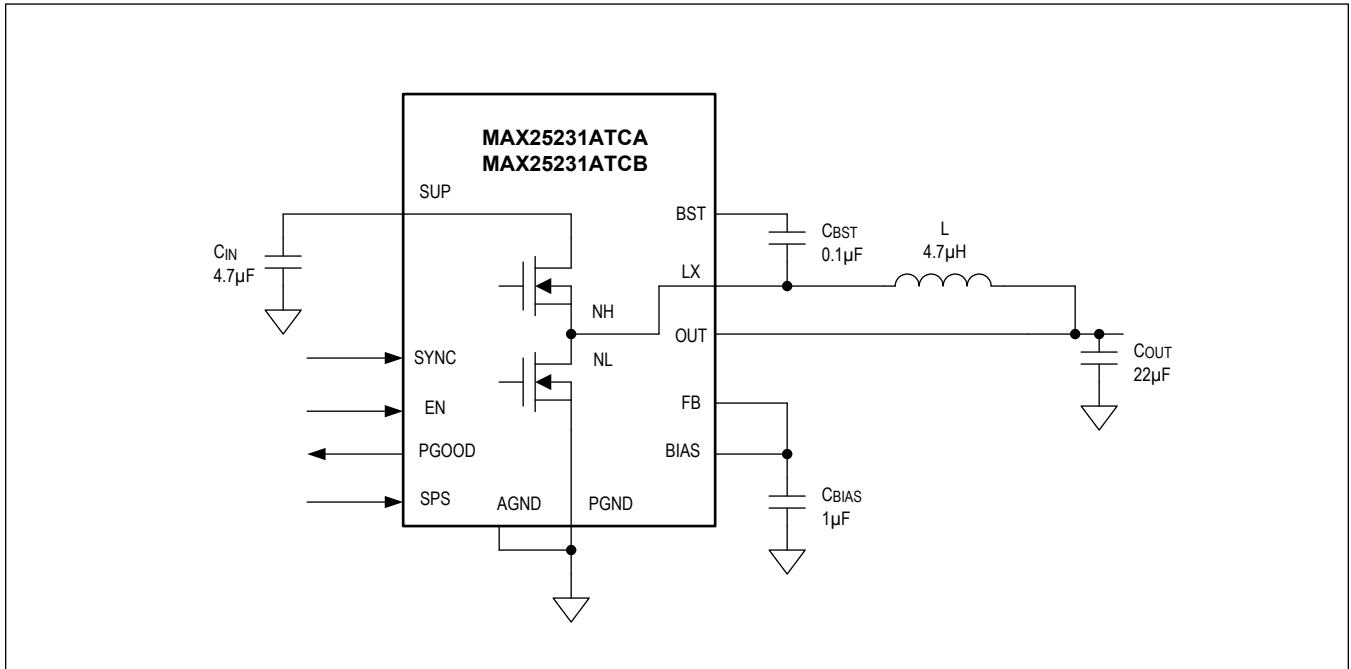

Circuit2 - Adjustable Output

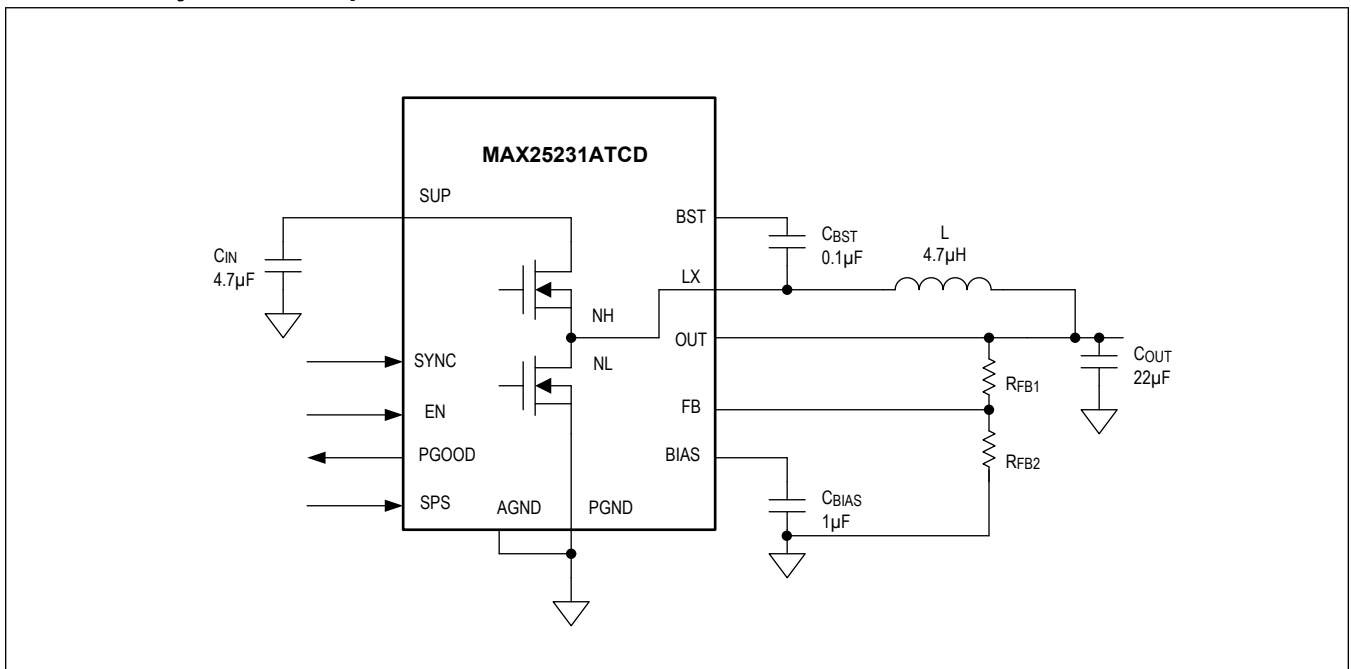

Ordering Information

PART	TEMP RANGE	PIN-PACKAGE	DESCRIPTION	I _{OUT}
MAX25231ATCA/V+	-40°C to +125°C	TD1233+2C	Fixed 5V output	1.2A
MAX25231ATCB/V+	-40°C to +125°C	TD1233+2C	Fixed 3.3V output	1.2A
MAX25231ATCD/V+	-40°C to +125°C	TD1233+2C	Adjustable output voltage between 3V to 10V	1.2A

Note: All parts are OTP versions, no metal mask differences.

/V denotes an automotive qualified part.

+Denotes a lead(Pb)-free/RoHS-compliant package.

Y = Side-wettable package.

* Future product—contact factory for availability

Revision History

REVISION NUMBER	REVISION DATE	DESCRIPTION	PAGES CHANGED
0	9/20	Initial release	—
1	4/21	Removing future products notation for MAX25231ATCD/V+	15
2	5/21	Update Package Information	3

For pricing, delivery, and ordering information, please visit Maxim Integrated's online storefront at <https://www.maximintegrated.com/en/storefront/storefront.html>.

Maxim Integrated cannot assume responsibility for use of any circuitry other than circuitry entirely embodied in a Maxim Integrated product. No circuit patent licenses are implied. Maxim Integrated reserves the right to change the circuitry and specifications without notice at any time. The parametric values (min and max limits) shown in the Electrical Characteristics table are guaranteed. Other parametric values quoted in this data sheet are provided for guidance.

X-ON Electronics

Largest Supplier of Electrical and Electronic Components

Click to view similar products for [Switching Voltage Regulators](#) category:

Click to view products by [Maxim](#) manufacturer:

Other Similar products are found below :

[FAN53610AUC33X](#) [FAN53611AUC123X](#) [FAN48610BUC33X](#) [FAN48610BUC45X](#) [FAN48617UC50X](#) [R3](#) [430464BB](#) [MIC45116-1YMP-T1](#) [KE177614](#) [MAX809TTR](#) [NCV891234MW50R2G](#) [NCP81103MNTXG](#) [NCP81203PMNTXG](#) [NCP81208MNTXG](#) [NCP81109GMNTXG](#) [SCY1751FCCT1G](#) [NCP81109JMNTXG](#) [AP3409ADNTR-G1](#) [LTM8064IY](#) [LT8315EFE#TRPBF](#) [NCV1077CSTBT3G](#) [XCL207A123CR-G](#) [MPM54304GMN-0002](#) [MPM54304GMN-0003](#) [XDPE132G5CG000XUMA1](#) [DA9121-B0V76](#) [LTC3644IY#PBF](#) [MP8757GL-P](#) [MIC23356YFT-TR](#) [LD8116CGL](#) [HG2269M/TR](#) [OB2269](#) [XD3526](#) [U6215A](#) [U6215B](#) [U6620S](#) [LTC3803ES6#TR](#) [LTC3803ES6#TRM](#) [LTC3412IFE](#) [LT1425IS](#) [MAX25203BATJA/VY+](#) [MAX77874CEWM+](#) [XC9236D08CER-G](#) [ISL95338IRTZ](#) [MP3416GJ-P](#) [BD9S201NUX-CE2](#) [MP5461GC-Z](#) [MPQ4415AGQB-Z](#) [MPQ4590GS-Z](#) [MCP1603-330IMC](#)