

MAX25300A/MAX25300B

12 μ V_{RMS} Low Noise 500mA LDO Linear Regulator

General Description

The MAX25300A/B are low-noise linear regulators that deliver up to 500mA of output current with only 12 μ V_{RMS} of output noise from 10Hz to 100kHz. These regulators maintain $\pm 1\%$ output accuracy over a wide input voltage range, requiring only 100mV of input-to-output headroom at full load. The 365 μ A no-load supply current is independent of dropout voltage.

The MAX25300A has nine pin-selectable output voltages: 1.2V, 1.5V, 1.8V, 2.5V, 3.0V, 3.1V, 3.3V, 4.0V, and 5V. The MAX25300B has a resistor adjustable output voltage in the range of 0.6V to 5.3V. The MAX25300B also includes an active-high POK output.

The MAX25300A/B are offered in an 8-pin TDFN package.

Applications

- Automotive Electronics
- Audio Systems
- High-Resolution Data Acquisition Systems

Benefits and Features

- 1.7V to 5.5V Input Voltage Range
- 0.6V to 5.3V Output Voltage Range
- 12 μ V_{RMS} Output Noise, 10Hz to 100kHz
- 365 μ A Operating Supply Current
- 70dB PSRR at 10kHz
- 500mA Maximum Output Current
- $\pm 1\%$ DC Accuracy Over Load, Line, and Temperature
- 100mV (Max) Dropout at 500mA Load (3.6V_{IN})
- < 0.1 μ A Shutdown Supply Current
- Stable with 2 μ F (Min) Output Capacitance
- Programmable Soft-Start Rate
- Overcurrent and Overtemperature Protection
- Output-to-Input Reversed Current Protection
- POK Output
- 2mm x 2mm 8-pin TDFN Package
- AEC-Q100
- -40°C to 125°C Operating Temperature

Ordering Information appears at end of datasheet.

MAX25300A/MAX25300B $12\mu\text{V}_{\text{RMS}}$ Low Noise 500mA LDO Linear Regulator

Typical Operating Circuits

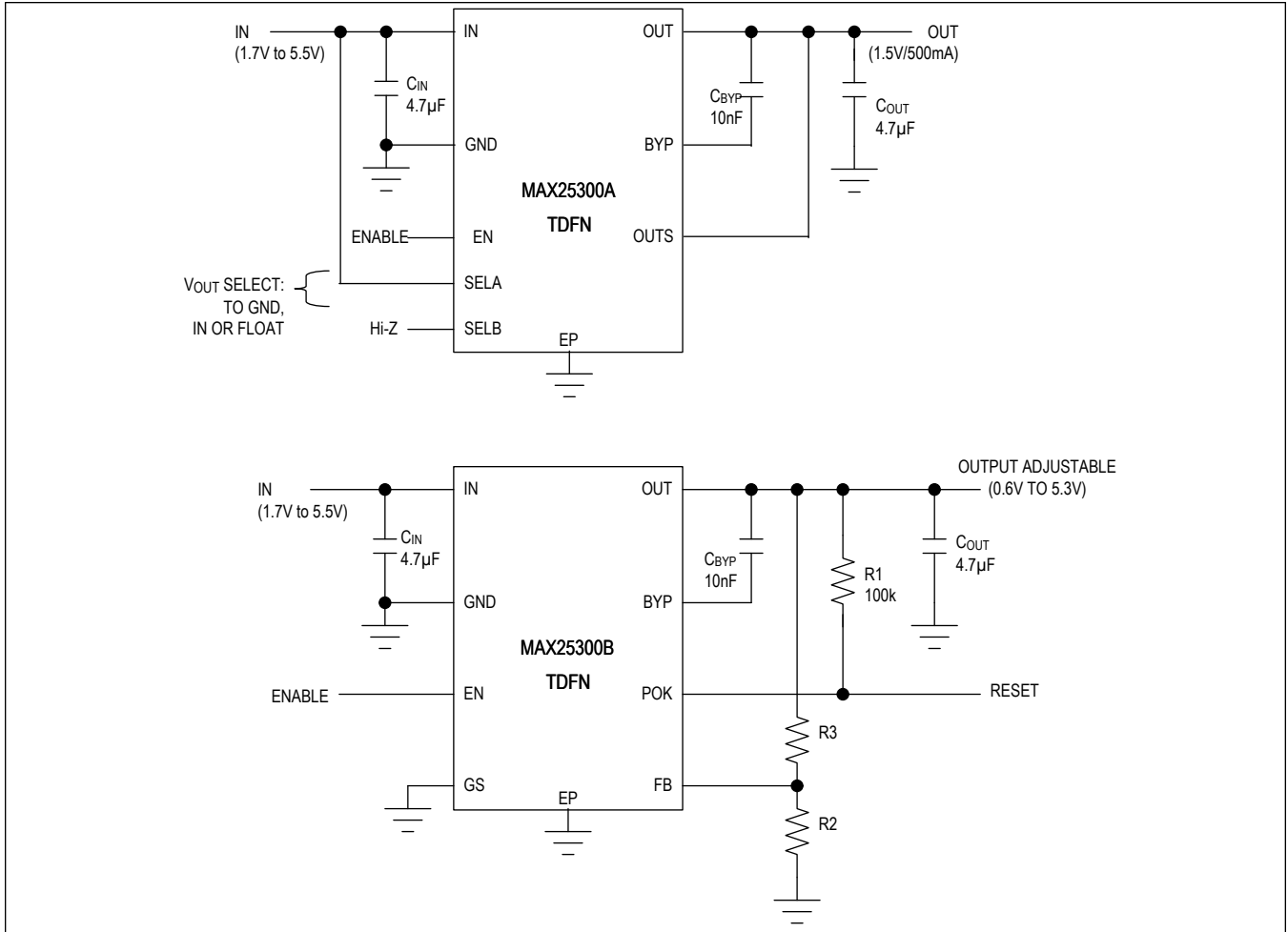

TABLE OF CONTENTS

| | |
|----------------------------------------------------|----|
| General Description | 1 |
| Applications | 1 |
| Benefits and Features | 1 |
| Typical Operating Circuits | 2 |
| Absolute Maximum Ratings | 5 |
| Package Information | 5 |
| TDFN | 5 |
| Electrical Characteristics | 5 |
| Typical Operating Characteristics | 8 |
| Pin Configurations | 9 |
| MAX25300A | 9 |
| MAX25300B | 10 |
| Pin Description | 10 |
| Functional Diagrams | 12 |
| Simplified Functional Diagram | 12 |
| Detailed Description | 13 |
| Enable (EN) | 13 |
| Bypass (BYP) | 13 |
| Protection Features | 13 |
| Output Voltage Configuration (MAX25300A) | 13 |
| Output Voltage Configuration (MAX25300B) | 14 |
| Power-OK (MAX25300B) | 14 |
| Input Capacitor | 14 |
| Output Capacitor | 14 |
| Thermal Considerations | 14 |
| Typical Application Circuits | 15 |
| Typical Application Circuit | 15 |
| Ordering Information | 15 |
| Revision History | 16 |

LIST OF TABLES

Table 1. MAX25300A Output Configuration 14

MAX25300A/MAX25300B $12\mu\text{V}_{\text{RMS}}$ Low Noise 500mA LDO Linear Regulator

Absolute Maximum Ratings

| | | |
|--------------------------------------------------------------------|------------------------------------------------|-----------------|
| IN, EN, POK, SELA, SELB, GS, OUTS, FB, BYP to GND-0.3V to +6V | Operating Temperature Range | -40°C to +125°C |
| OUT to GND | Maximum Junction Temperature | +150°C |
| Output Short-Circuit Duration | Storage Temperature Range | -65°C to +150°C |
| Continuous Power Dissipation ($T_A = +70^\circ\text{C}$) . | Lead Temperature (Soldering, 10 seconds) | +300°C |
| TDFN (derate 9.8mW/°C above 70°C) | Soldering Temperature (reflow) | +260°C |
| | | 784mW |

Stresses beyond those listed under "Absolute Maximum Ratings" may cause permanent damage to the device. These are stress ratings only, and functional operation of the device at these or any other conditions beyond those indicated in the operational sections of the specifications is not implied. Exposure to absolute maximum rating conditions for extended periods may affect device reliability.

Package Information

TDFN

| | |
|------------------------------------------------|-------------------------|
| Package Code | T822+3C |
| Outline Number | 21-0168 |
| Land Pattern Number | 90-0065 |
| Thermal Resistance, Single-Layer Board: | |
| Junction to Ambient (θ_{JA}) | 130°C/W |
| Junction to Case (θ_{JC}) | 8°C/W |
| Thermal Resistance, Four-Layer Board: | |
| Junction to Ambient (θ_{JA}) | 102°C/W |
| Junction to Case (θ_{JC}) | 8°C/W |

For the latest package outline information and land patterns (footprints), go to www.maximintegrated.com/packages. Note that a "+", "#", or "-" in the package code indicates RoHS status only. Package drawings may show a different suffix character, but the drawing pertains to the package regardless of RoHS status.

Package thermal resistances were obtained using the method described in JEDEC specification JESD51-7, using a four-layer board. For detailed information on package thermal considerations, refer to www.maximintegrated.com/thermal-tutorial.

Electrical Characteristics

($V_{IN} = 3.6\text{V}$, $T_J = -40^\circ\text{C}$ to $+125^\circ\text{C}$, $C_{BYP} = 10\text{nF}$, $C_{IN} = 4.7\mu\text{F}$, $C_{OUT} = 4.7\mu\text{F}$, typical values are at $T_J = +25^\circ\text{C}$, unless otherwise specified. (Note 1))

| PARAMETER | SYMBOL | CONDITIONS | MIN | TYP | MAX | UNITS |
|----------------------------------|----------------|------------------------------------------------------------------------------------------------------|----------------------------|------|-------|---------------|
| Input Voltage Range | V_{IN} | Guaranteed by Output Accuracy | 1.7 | | 5.5 | V |
| Input Undervoltage Lockout | V_{IN_UVLO} | V_{IN} rising, 100mV hysteresis | 1.5 | 1.6 | 1.7 | V |
| Output Voltage Range | V_{OUT} | $V_{IN} > V_{OUT} + 0.1\text{V}$ | 0.6 | | 5.3 | V |
| Output Capacitance | C_{OUT} | For stability and proper operation | 2 | 4.7 | | μF |
| Supply Current | I_Q | $I_{OUT} = 0\text{mA}$ | | 365 | 600 | μA |
| | $I_{SHUTDOWN}$ | $V_{EN} = 0\text{V}$ | $T_J = +25^\circ\text{C}$ | 0.01 | 0.1 | |
| | | | $T_J = +125^\circ\text{C}$ | 2400 | | nA |
| Output Accuracy (MAX25300A Only) | ACC25300A | I_{OUT} from 0.1mA to 500mA, V_{IN} from $V_{OUT} + 0.3\text{V}$ to 5.5V, $V_{IN} > 1.7\text{V}$ | -1 | | +1 | % |
| Output Accuracy (MAX25300B Only) | ACC25300B | I_{OUT} from 0.1mA to 500mA, V_{IN} from $V_{OUT} + 0.3\text{V}$ to 5.5V, $V_{IN} > 1.7\text{V}$ | 0.594 | 0.6 | 0.606 | V |
| Load Regulation | | I_{OUT} from 0.1mA to 500mA, $V_{IN} = V_{OUT} + 300\text{mV}$, $V_{OUT} = 2.5\text{V}$ | | 0.07 | | %/V |

MAX25300A/MAX25300B $12\mu\text{V}_{\text{RMS}}$ Low Noise 500mA LDO Linear Regulator

Electrical Characteristics (continued)

($V_{\text{IN}} = 3.6\text{V}$, $T_{\text{J}} = -40^{\circ}\text{C}$ to $+125^{\circ}\text{C}$, $C_{\text{BYP}} = 10\text{nF}$, $C_{\text{IN}} = 4.7\mu\text{F}$, $C_{\text{OUT}} = 4.7\mu\text{F}$, typical values are at $T_{\text{J}} = +25^{\circ}\text{C}$, unless otherwise specified. (Note 1))

| PARAMETER | SYMBOL | CONDITIONS | | MIN | TYP | MAX | UNITS |
|-------------------------------------------|------------------|--------------------------------------------------------------------------------------------------------------------------------------------------|---------------------------------------|-------|--------|------|----------------------------|
| Load Transient | | $I_{\text{OUT}} = 50\text{mA}$ to 500mA to 50mA , $t_{\text{RISE}} = t_{\text{FALL}} = 1\mu\text{s}$ | | | 50 | | mV |
| Line Regulation | | V_{IN} from $V_{\text{OUT}} + 0.3\text{V}$ to 5.5V , $V_{\text{IN}} > 1.7\text{V}$, $I_{\text{OUT}} = 200\text{mA}$ | | | 0.06 | | %/V |
| Line Transient | | $V_{\text{IN}} = 4\text{V}$ to 5V to 4V , $I_{\text{OUT}} = 500\text{mA}$, $t_{\text{RISE}} = t_{\text{FALL}} = 5\mu\text{s}$ | | | 3 | | mV |
| Dropout Voltage (Note 2) | | $I_{\text{OUT}} = 500\text{mA}$ | $V_{\text{IN}} = 3.6\text{V}$ | | 26 | 100 | mV |
| | | | $V_{\text{IN}} = 2.5\text{V}$ | | 36 | 200 | |
| | | | $V_{\text{IN}} = 1.7\text{V}$ | | 63 | 300 | |
| Current Limit | | $V_{\text{OUTS/FB}} = 0\text{V}$, $V_{\text{IN}} - V_{\text{OUT}} = 500\text{mV}$ | $V_{\text{IN}} = 1.7\text{V}$ | 600 | 700 | 800 | mA |
| | | | $V_{\text{IN}} = 3.6\text{V}$ | 600 | 700 | 800 | |
| Output Noise | | $I_{\text{OUT}} = 100\text{mA}$, 10Hz to 100kHz | $C_{\text{BYP}} = 47\text{nF}$ | | 12 | | μV_{RMS} |
| Power Supply Rejection Ratio | PSRR | $I_{\text{OUT}} = 100\text{mA}$ | $f = 1\text{kHz}$ | | 70 | | dB |
| | | | $f = 10\text{kHz}$ | | 70 | | |
| | | | $f = 100\text{kHz}$ | | 60 | | |
| | | | $f = 1\text{MHz}$ | | 40 | | |
| BYP Capacitor Range | C_{BYP} | Regulator remains stable | | 0.001 | | 0.1 | μF |
| BYP Soft-Start Current | | From BYP to GND during startup | | | 50 | | μA |
| EN Input Threshold | | V_{IN} from 1.7V to 5.5V | EN rising | | 0.8 | 1.2 | V |
| | | | EN falling | 0.4 | 0.7 | | |
| EN Input Leakage Current | | V_{EN} from 1.7V to 5.5V | $T_{\text{J}} = +25^{\circ}\text{C}$ | -1 | +0.001 | +1 | μA |
| | | | $T_{\text{J}} = +125^{\circ}\text{C}$ | | 0.01 | | |
| POK Threshold (MAX25300B Only) | | V_{OUT} when POK switches | V_{OUT} rising | 88 | 91 | 94 | % |
| | | | V_{OUT} falling | | 88 | | |
| POK Voltage, Low (MAX25300B Only) | | $I_{\text{POK}} = 1\text{mA}$ | | | 10 | 100 | mV |
| POK Leakage Current (MAX25300B Only) | | $V_{\text{POK}} = 5.5\text{V}$ | $T_{\text{J}} = +25^{\circ}\text{C}$ | -0.1 | +0.001 | +0.1 | μA |
| | | | $T_{\text{J}} = +125^{\circ}\text{C}$ | | 0.01 | | |
| SELA/B Input Resistance (MAX25300A Only) | | When shorted to GND or IN. | | | | 500 | Ω |
| | | When Hi-Z | | 1 | | | M Ω |
| SELA/B Input Capacitance (MAX25300A Only) | | When Hi-Z | | | | 10 | pF |
| Input Reverse Current Threshold | | $V_{\text{OUT}} = 3.6\text{V}$, when V_{IN} falls to 0V | | | 200 | | mA |
| Thermal Shutdown Threshold | | T_{J} when output turns on/off | T_{J} rising | | 165 | | $^{\circ}\text{C}$ |
| | | | T_{J} falling | | 150 | | |

MAX25300A/MAX25300B $12\mu\text{V}_{\text{RMS}}$ Low Noise 500mA LDO Linear Regulator

Note 1: Limits over the specified operating temperature and supply voltage range are guaranteed by design and characterization, and production tested at $T_J = 25^\circ\text{C}$ only.

Note 2: Dropout voltage is defined as $(V_{\text{IN}} - V_{\text{OUT}})$, when V_{OUT} is 5% lower than the value of V_{OUT} when $V_{\text{IN}} = V_{\text{OUT}} + 0.5\text{V}$.

Typical Operating Characteristics

(MAX25300B, V_{IN} = 5.0V, V_{OUT} = 3.3V, T_A = 25°C, C_{IN} = 4.7 μ F, C_{OUT} = 4.7 μ F, unless otherwise noted.)

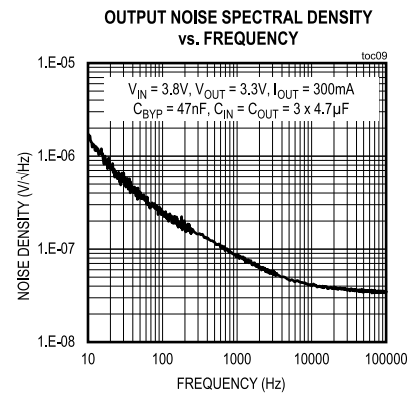
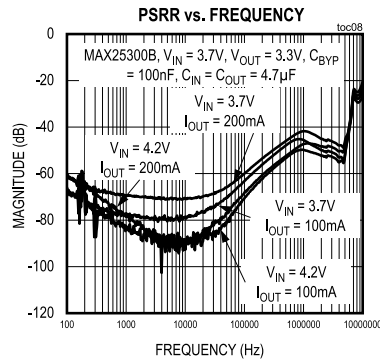
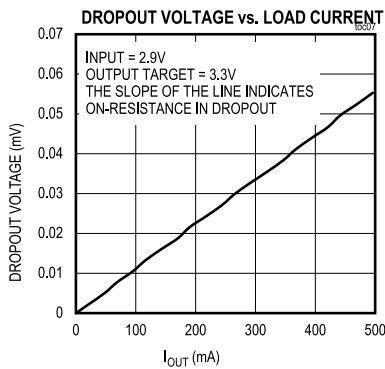
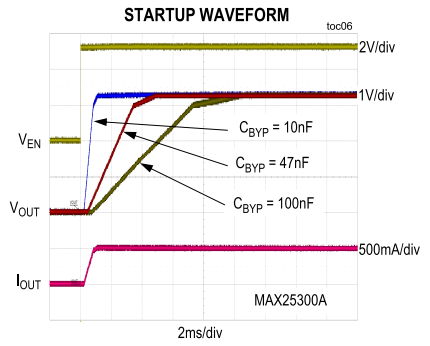
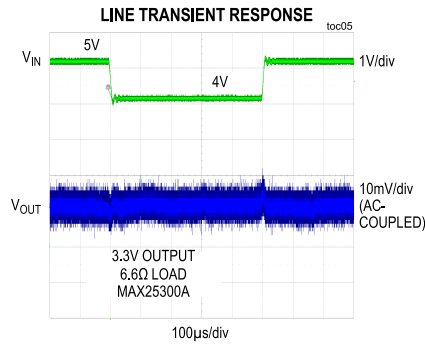
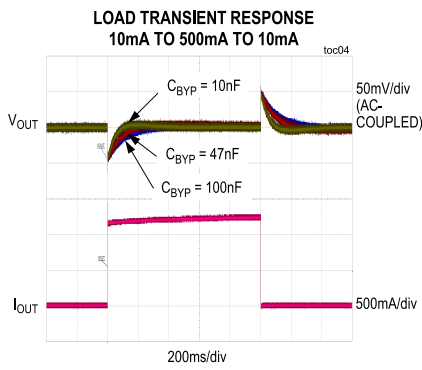
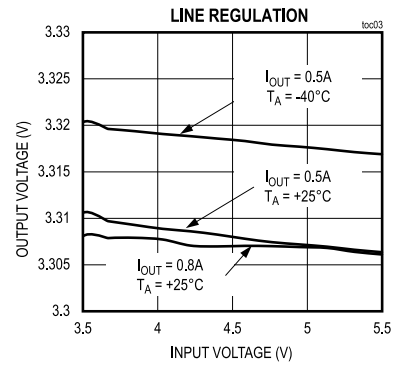
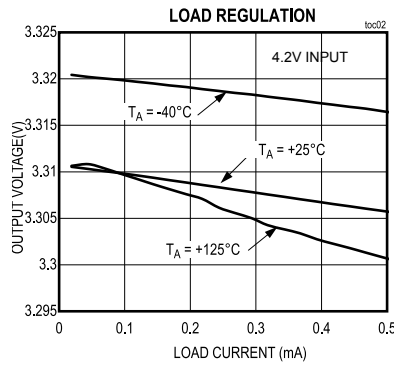
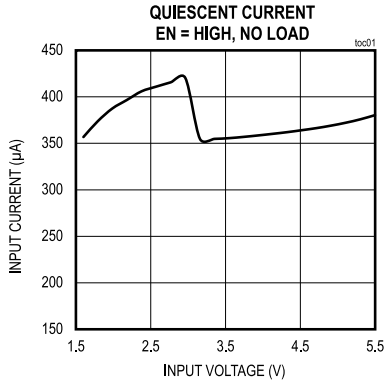

Pin Configurations

MAX25300A

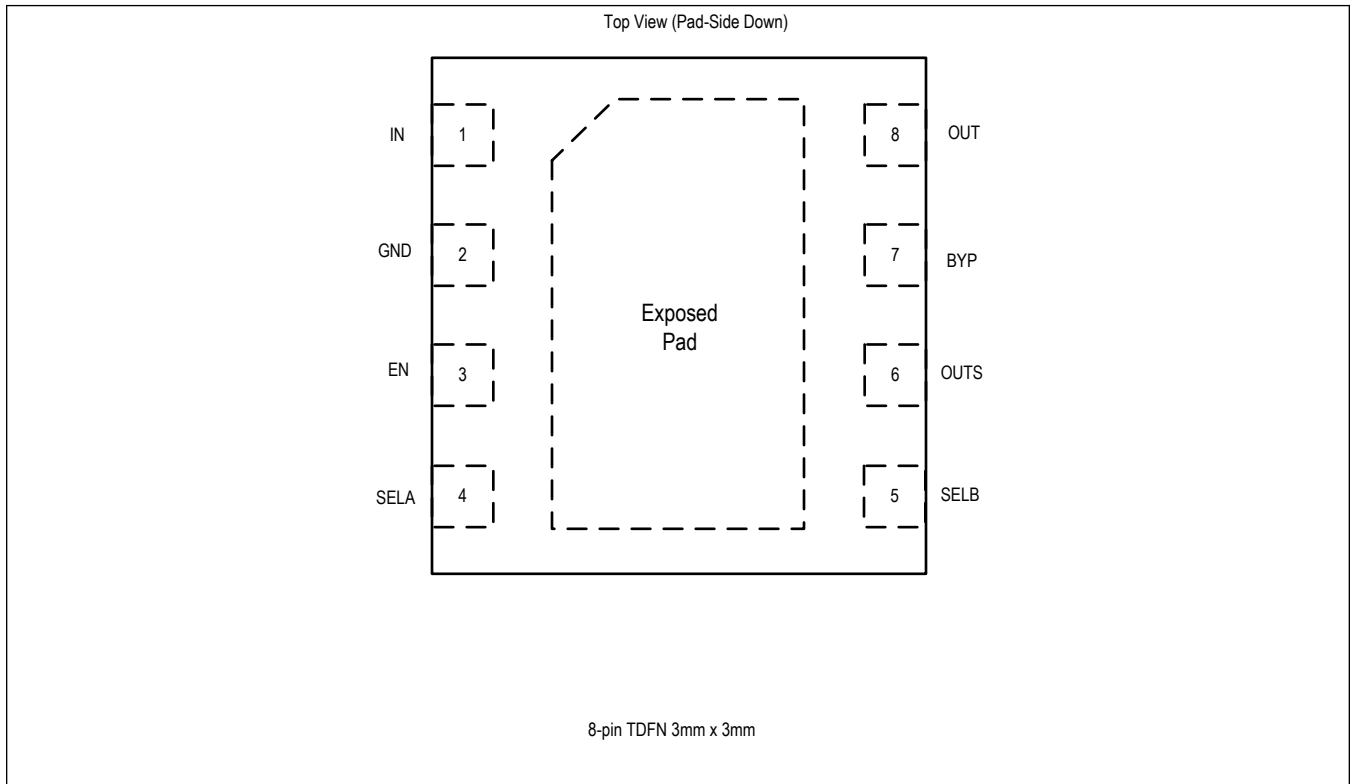

MAX25300A/MAX25300B 12 μ V_{RMS} Low Noise 500mA LDO Linear Regulator

MAX25300B

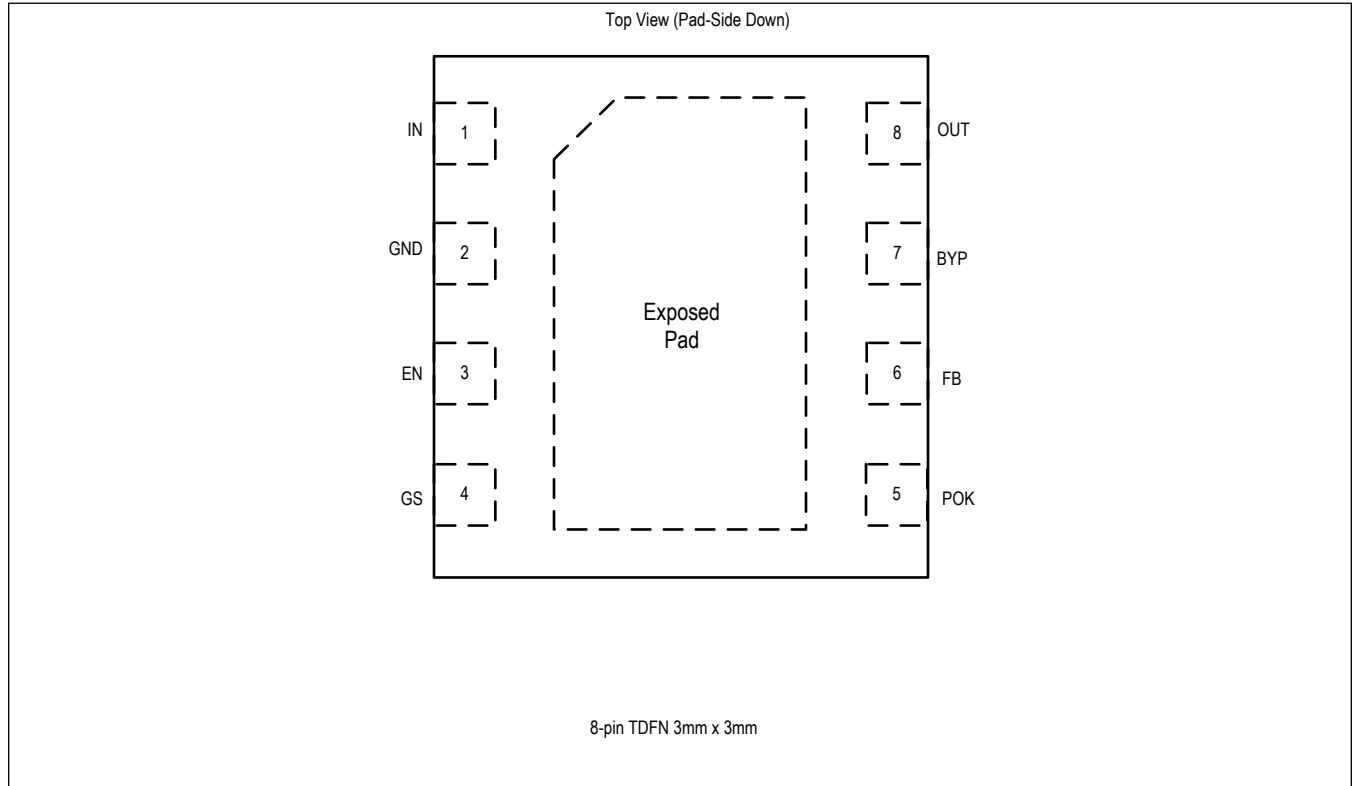

Pin Description

| PIN | | NAME | FUNCTION |
|-----------|-----------|------|---------------------------------------------------------------------------------------------------------------------------------------------------------------------------------------------------------------------|
| MAX25300A | MAX25300B | | |
| 1 | 1 | IN | Regulator Supply Input. Connect to a voltage between 1.7V and 5.5V and bypass with a 4.7 μ F capacitor from IN to GND. |
| 2 | 2 | GND | Regulator Ground. Bring IN and OUT bypass capacitor GND connections to this pin for best performance. |
| 3 | 3 | EN | Enable Input. Connect this pin to a logic signal to enable (V_{EN} high) or disable (V_{EN} low) the regulator output. Connect to IN to keep the output enabled whenever a valid supply voltage is present. |
| 4 | — | SELA | Output Select Input. Connect to GND, IN or leave unconnected to select one of three states. The state of the SELA and SELB pins are read when the device is enabled and used to select one of nine output voltages. |
| — | 4 | GS | Ground Sense. Connect GS to GND. |
| 5 | — | SELB | Output Select Input. Connect to GND, IN or leave unconnected to select one of three states. The state of the SELA and SELB pins are read when the device is enabled and used to select one of nine output voltages. |
| — | 5 | POK | Power On Reset Output. Connect a pullup resistor from this pin to a supply to create a reset signal that goes high after the regulator output has reached its regulation voltage. |
| 6 | — | OUTS | Output Voltage Sense Input. Connect to the load at a point where accurate regulation is required to eliminate resistive metal drops. |

Pin Description (continued)

| PIN | | NAME | FUNCTION |
|-----------|-----------|------|-----------------------------------------------------------------------------------------------------------------------------------------------------------------------------------------------------------------------------------|
| MAX25300A | MAX25300B | | |
| — | 6 | FB | Feedback Divider Input. Connect a resistor divider string from OUT to GND with the mid-point tied to this pin to set the output voltage. In the Typical Application Circuits, $V_{\text{OUT}} = 0.6\text{V} \times (1 + R3/R2)$. |
| 7 | 7 | BYP | Bypass Capacitor Input. Connect a $0.001\mu\text{F}$ to $0.1\mu\text{F}$ capacitor between OUT and BYP to reduce output noise and set the regulator soft-start rate. |
| 8 | 8 | OUT | Regulator Output. Sources up to 500mA at the output regulation voltage. Bypass with a $4.7\mu\text{F}$ ($2\mu\text{F}$ minimum including voltage derating) low ESR ($<0.03\Omega$) capacitor to GND. |
| EP | EP | EP | Exposed Pad (TDFN only). Connect the exposed pad to a ground plane with low thermal resistance to ambient to provide best heat sinking. |

Functional Diagrams

Simplified Functional Diagram

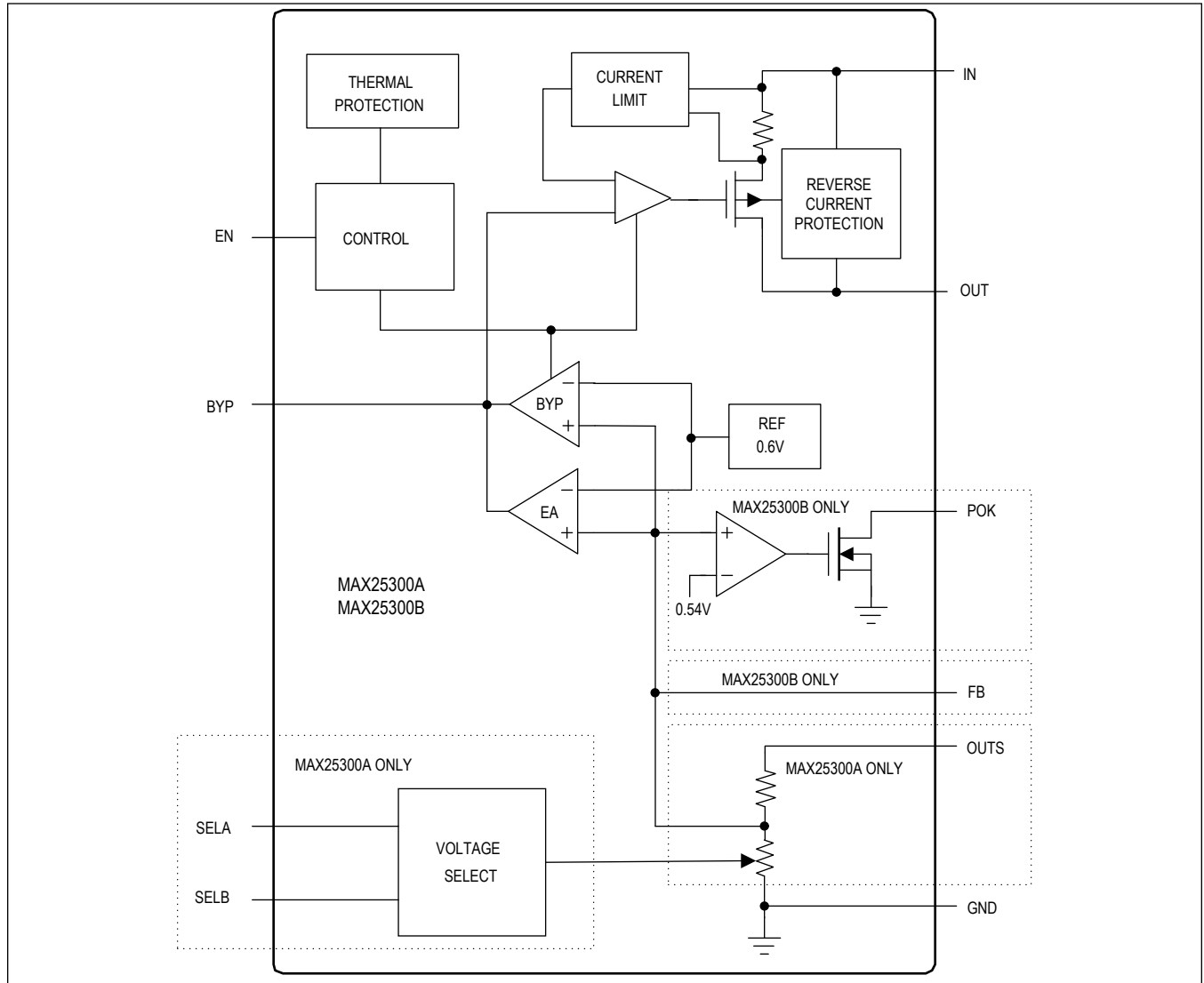

Detailed Description

The MAX25300A/B low noise linear regulators deliver up to 500mA of output current with only 12 μ V_{RMS} of output noise in a 10Hz to 100kHz bandwidth. These regulators maintain their output voltage over a wide input range, requiring only 100mV of input-to-output headroom at full load.

The MAX25300A/B maintain a low 365 μ A typical supply current, independent of the load current and dropout voltage. The regulator control circuitry includes a programmable soft-start circuit, short-circuit, reverse input current, and thermal overload protection. Other features include an enable input and power-okay (POK) output (MAX25300B only). See [Functional Diagrams](#).

Enable (EN)

The MAX25300A/MAX25300B include an enable input (EN). Pull EN low to shut down the output, or drive EN high to enable the output. If a separate shutdown signal is not available, connect EN to IN.

Bypass (BYP)

The capacitor connected from BYP to OUT filters the noise of the reference, feedback resistors and regulator input stage, and provides a high-speed feedback path for improved transient response. A 0.01 μ F capacitor rolls off input noise at approximately 32Hz.

The slew rate of the output voltage during startup is also determined by the BYP capacitor. A 0.01 μ F capacitor sets the slew rate to 5V/ms. This startup rate results in a 50mA slew current drawn from the input at startup to charge the 10 μ F output capacitance.

The BYP capacitor value can be adjusted from 0.001 μ F to 0.1 μ F to change the startup slew rate according to the following formula:

$$\text{StartupSlewRate} = (5V / \text{ms}) \times (0.01 \mu F / C_{\text{BYP}})$$

where C_{BYP} is in μ F.

Note that this slew rate applies only at startup. Recovery from a short circuit will occur at a slew rate approximately 500 times slower.

Also note that, being a low-frequency filter node, BYP is sensitive to leakage. BYP leakage currents above 10nA cause measurable inaccuracy at the output and should be avoided.

Protection Features

The MAX25300A/B are fully protected from an output short circuit by a current-limiting and thermal-overload circuit. If the output is shorted to GND, the output current is limited to 700mA (typ). Under these conditions, the part quickly heats up. When the junction temperature reaches 165°C, a thermal limit circuit shuts off the output device. When the junction cools to 150°C, the output turns back on in an attempt to re-establish regulation. While the fault persists, the output current cycles on and off, as the junction temperature slews between 150°C and 165°C.

The MAX25300A/B are also protected against reverse current when the output voltage is higher than the input. In the event that extra output capacitance is used at the output, a power-down transient at the input would normally cause a large reverse current through a conventional regulator. The MAX25300A/B include a reverse-voltage detector that trips when IN drops 10mV below OUT, shutting off the regulator and opening the pMOS body diode connection, preventing any reverse current. Once the reverse voltage is removed, the output will start up again.

Output Voltage Configuration (MAX25300A)

The MAX25300A output can be set to one of nine voltages by shorting or opening the SELA and SELB inputs, as shown in [Table 1](#). SELA and SELB should be connected to GND, IN, or left unconnected. Alternatively, they may be driven high, low, or open with external logic. However, the states of SELA and SELB are sampled only at startup. The regulation voltage can be set to a different level by cycling EN or IN momentarily to GND.

Table 1. MAX25300A Output Configuration

| V _{OUT} (V) | SELA STATE | SELB STATE |
|----------------------|-------------|-------------|
| 1.2 | Unconnected | IN |
| 1.5 | IN | Unconnected |
| 1.8 | Unconnected | GND |
| 2.5 | Unconnected | Unconnected |
| 3.0 | GND | GND |
| 3.1 | GND | IN |
| 3.3 | GND | Unconnected |
| 4.0 | IN | GND |
| 5.0 | IN | IN |

Output Voltage Configuration (MAX25300B)

The MAX25300B uses external feedback resistors to set the output regulation voltage, as shown in [Functional Diagrams](#). The output can be set from 0.6V to 5.3V. Set the lower feedback resistor R2 to 300kΩ or less to minimize FB input bias current error. Then calculate the value of the upper feedback resistor R3 as follows:

$$R3 = R2 \times \left(\frac{V_{OUT}}{V_{FB}} - 1 \right)$$

where V_{FB} is the feedback regulation voltage of 0.6V. To set the output voltage to 2.5V, for example, R3 should be:

$$R3 = 300k\Omega \times \left(\frac{2.5V}{0.6V} - 1 \right) = 950k\Omega$$

Power-OK (MAX25300B)

The MAX25300B includes an additional open-drain output, POK, that goes high to indicate the output voltage is in regulation. Connect a pullup resistor from this pin to an external supply. During startup, POK stays low until the output voltage rises to 91%(typ) of its regulation level. If an overload occurs at the output, or the output is shutdown, POK goes low.

Input Capacitor

A 4.7μF ceramic capacitor is recommended for the input. Select a capacitor that maintains its capacitance over temperature and DC bias. Capacitors with X5R or X7R temperature characteristics generally perform well.

Output Capacitor

A minimum of 2μF capacitance is required at OUT to ensure stability. Select a ceramic capacitor that maintains its capacitance (2μF minimum) over temperature and DC bias. Capacitors with X5R or X7R temperature characteristics generally perform well. For example, the ceramic capacitor part number GRM155R60J475ME47 from Murata (4.7μF/ 6.3V/X5R) derates to around 2.9μF with 1.8V DC bias.

Thermal Considerations

The MAX25300A/B are packaged in an 8-pin 2mm x 2mm TDFN package with an exposed paddle. The exposed paddle is the main path for heat to leave the IC, and therefore must be connected to a ground plane with thermal vias to allow heat to dissipate from the device. Thermal properties of the IC package are given in the [Package Information](#) section.

MAX25300A/MAX25300B 12 μ V_{RMS} Low Noise 500mA LDO Linear Regulator

Typical Application Circuits

Typical Application Circuit

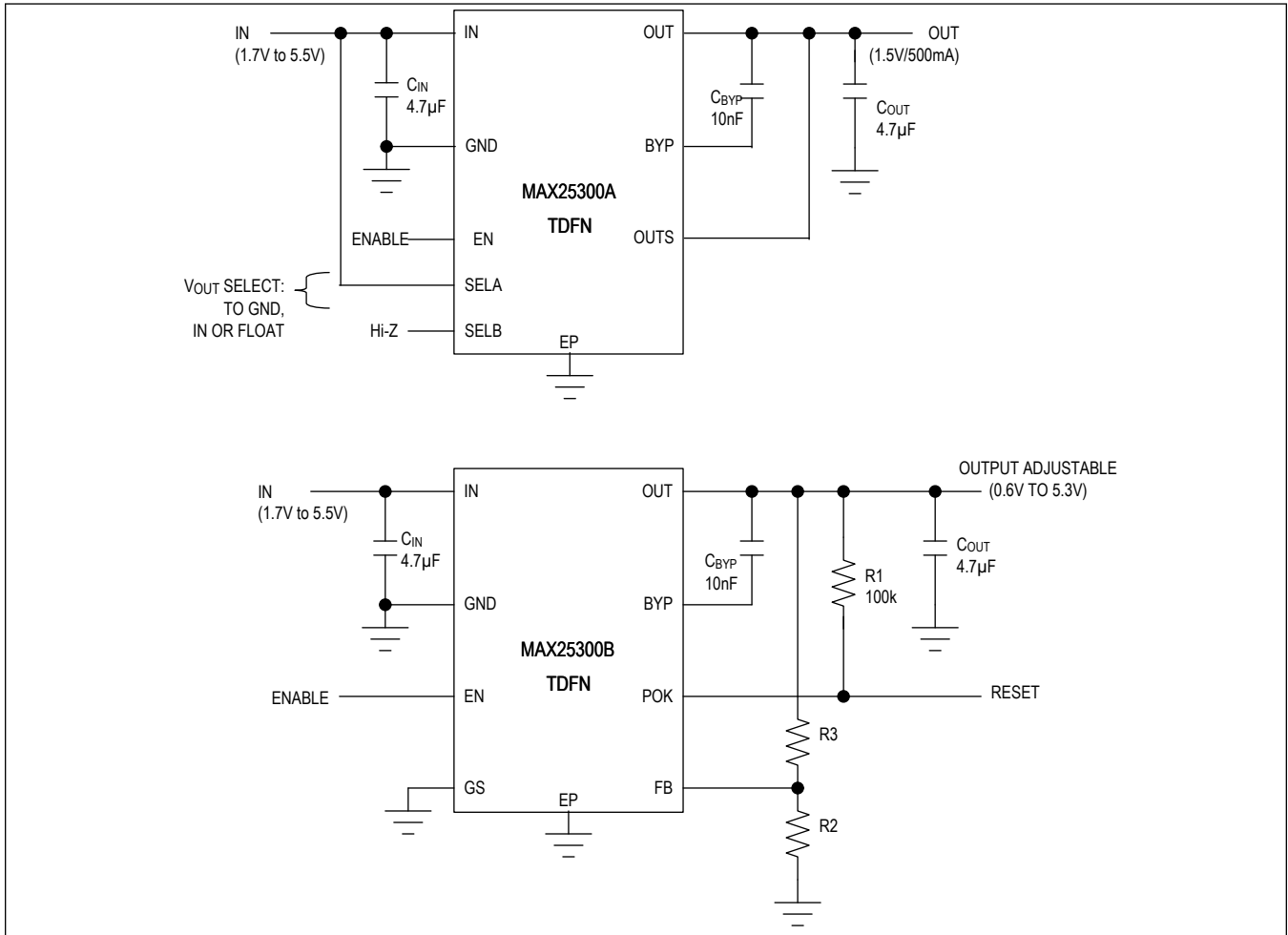

Ordering Information

| PART NUMBER | TEMPERATURE RANGE | PIN-PACKAGE | OUTPUT VOLTAGE SENSING |
|-----------------|-------------------|-------------|--------------------------------------------|
| MAX25300AATA/V+ | -40°C to +125°C | 8 TDFN | Pin-Selectable Output Voltage |
| MAX25300BATA/V+ | -40°C to +125°C | 8 TDFN | External Resistor Feedback with POK output |

/V Denotes an automotive qualified part.

+Denotes a lead(Pb)-free/RoHS-compliant package.

MAX25300A/MAX25300B 12 μ V_{RMS} Low Noise 500mA LDO Linear Regulator

Revision History

| REVISION NUMBER | REVISION DATE | DESCRIPTION | PAGES CHANGED |
|-----------------|---------------|-----------------|---------------|
| 0 | 6/20 | Initial release | — |

For pricing, delivery, and ordering information, please visit Maxim Integrated's online storefront at <https://www.maximintegrated.com/en/storefront/storefront.html>.

Maxim Integrated cannot assume responsibility for use of any circuitry other than circuitry entirely embodied in a Maxim Integrated product. No circuit patent licenses are implied. Maxim Integrated reserves the right to change the circuitry and specifications without notice at any time. The parametric values (min and max limits) shown in the Electrical Characteristics table are guaranteed. Other parametric values quoted in this data sheet are provided for guidance.

X-ON Electronics

Largest Supplier of Electrical and Electronic Components

Click to view similar products for [Linear Voltage Regulators](#) category:

Click to view products by [Maxim](#) manufacturer:

Other Similar products are found below :

[LV56831P-E](#) [LV5684PVD-XH](#) [MCDTSA6-2R](#) [L7815ACV-DG](#) [LV56801P-E](#) [TCR3DF13,LM\(CT](#) [TCR3DF39,LM\(CT](#) [TLE42794G](#)
[L78L05CZ/1SX](#) [L78LR05DL-MA-E](#) [LM317T](#) [636416C](#) [714954EB](#) [LV5680P-E](#) [L78M15CV-DG](#) [L79M05T-E](#) [TLS202A1MBVHTSA1](#)
[L78LR05D-MA-E](#) [NCV317MBTG](#) [NTE7227](#) [NCV78M09BDTRKG](#) [LV5680NPVC-XH](#) [LT1054CN8](#) [ME6208A50M3G](#) [SL7533-8](#)
[ME6231A50M3G](#) [ME6231A50PG](#) [ME6231C50M5G](#) [AMS1117S-3.3](#) [AMS1117-5.0](#) [AMS1117S-5.0](#) [AMS1117-3.3](#) [MD5118](#) [MD5121](#)
[MD5127](#) [MD5128](#) [MD5130](#) [MD5144](#) [MD5150](#) [MD5115](#) [MD5125](#) [MD5136](#) [MD5140](#) [MD5110](#) [MD52E18WB6](#) [MD52E33WB6](#)
[MD52E15QA3](#) [MD52E21QA3](#) [MD52E25QA3](#) [MD52E28QA3](#)