

MAX25410B Evaluation Kit

Evaluates: MAX25410

General Description

The MAX25410B evaluation kit (EV kit) demonstrates Maxim's automotive USB-PD port protector with host charger adapter emulation, system-level ESD, short-to-VBUS protection, and short-to-battery protection.

The EV kit is designed to be plugged into any USB 2.0 Type-C port, effectively providing a new fully protected Type-C port. The EV kit only requires one external power-supply source to operate. Protection is always maintained, whether or not the input supply is present.

The MAX25410B can be used to protect any USB 2.0 interface and USB-PD controller. Additionally, MAX25410B automatic fault recovery enables a seamless user experience.

The MAX25410B also features an integrated host-charger port-detection circuitry that adheres to the USB-IF BC1.2 battery-charging specification, Apple® iPod/iPhone/iPad and Samsung® 2.0A, and Chinese Telecommunication Industry Standard YD/T 1591-2009 charge emulation.

The EV kit is populated with a MAX25410BGTE/V+ (variant with auto-CDP and auto DCP/Apple 2.4A host-charger emulation modes). Other variants can be used by simply replacing the IC on the EV kit.

Ordering Information appears at end of data sheet.

Features and Benefits

- USB Type-C CC1/CC2 Protection Switches
- USB 2.0 D+/D- Protection Switches with 1GHz Bandwidth
- 24V CC and USB 2.0 Protection against Short-to-VBUS
- Automatic Fault Detection and Recovery with Industry-Compliant Reset Timings
- Integrated BC1.2, Apple and Samsung Charge Emulation
 - Supports BC1.2 CDP and DCP Modes
 - Apple 2.4A, 1.0A
 - Samsung 2.0A
 - China YD/T 1591-2009 Charging Specification
 - Compatible with USB On-the-Go Specification and Apple CarPlay
- High ESD Protection (HVD+/HVD-, HVCC1/HVCC2)
 - ±2kV Human Body Model
 - ±15kV ISO 10605 Air Gap
 - ±8kV ISO 10605 Contact
 - ±15kV IEC 61000-4-2 Air Gap
 - ±8kV IEC 61000-4-2 Contact
- Proven PCB Layout

Box Content

- MAX25410B EV Kit Fully Assembled and Tested

*Apple, iPod, iPhone, and iPad are registered trademarks of Apple Inc.
Samsung is a registered trademark of Samsung Electronics Co., Ltd.*

Getting Started

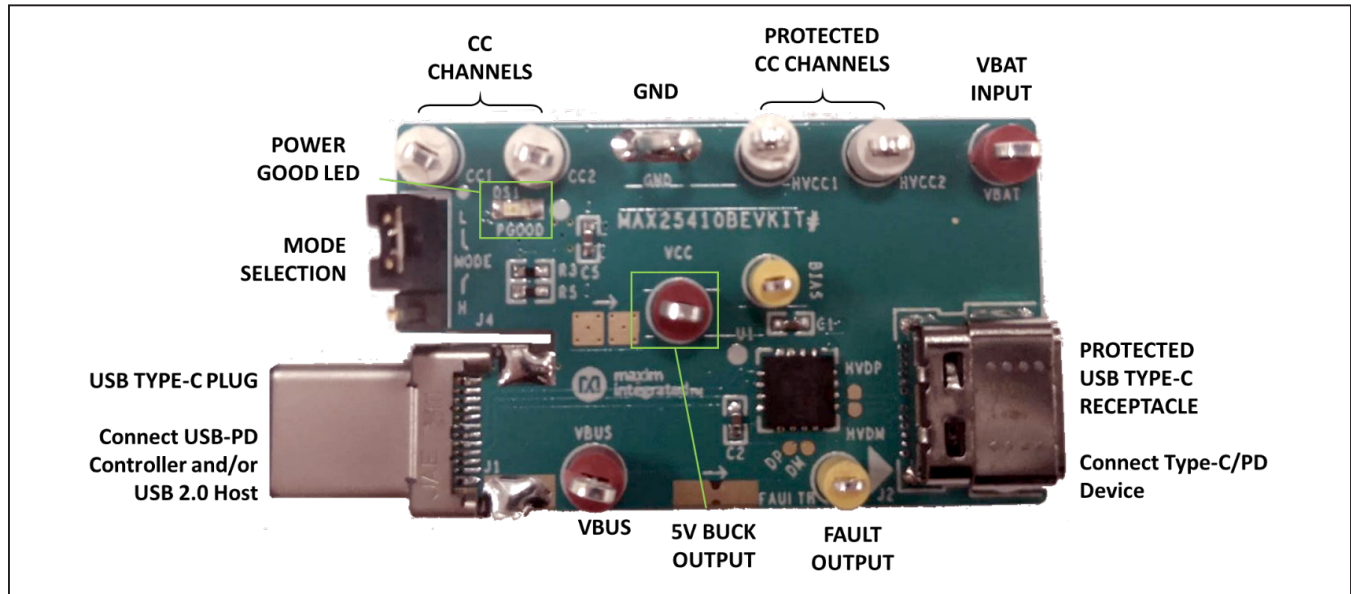

Figure 1. EV Kit Interfaces

Table 1. Jumper List

JUMPER	FUNCTION	CONTROL	
J4	Charge Mode Selection	Low: auto-CDP	High: auto-DCP/Apple 2.4A

Note: This table applies to the default IC installed on the EV kit: MAX25410BGTE/V+. To evaluate USB data pass-through mode, replace U1 with the required IC. Refer to the *Ordering Information* in the MAX25410 data sheet.

Table 2. Test-Point List

TEST POINT	FUNCTION
CC1, CC2	Low-voltage, unprotected CC channels from upstream USB-PD controller. Input to the MAX25410B's CC pass-through switches.
HVCC1, HVCC2	Protected CC channels. The CC pass-through switches are always closed whenever PGOOD is illuminated and no fault has occurred. Test points for monitoring only.
VBUS	Upstream VBUS. Can also be forced externally if the Type-C plug is left unconnected.
FAULTB or $\overline{\text{FAULT}}$	Fault indicator output - Refer to the <i>Fault Table</i> in the MAX25410 data sheet.
VCC	Regulated 5V/0.6A output from MAX20075 Automotive Buck Converter. Provides power to MAX25410B.
BIAS	Internal MAX25410B LDO output. Test point for monitoring only.
VBAT	Main EV kit input power. Connect to 14V power supply or car battery.
GND	Ground. Connect power supply negative terminal and all probe references to the GND test point.
DP/DM	Test pads to monitor low-voltage USB 2.0 D+/D- signals from upstream transceiver. Note: These signals are routed with 90Ω differential impedance.
HVDP/HVDM	Test pads to monitor high-voltage-protected USB 2.0 signals and charge emulation. Note: These signals are routed with 90Ω differential impedance.

Important: High-voltage events (i.e., short-to-VBUS) must be applied only through the Type-C receptacle and not directly to these test points in order to avoid damage to the ICs.

A) CC Short-to-VBUS Protection

The following procedure demonstrates MAX25410B's response to a CC short-to-VBUS event through the USB-C connector.

Required Equipment

- MAX25410B EV kit
- 14V/1A DC power supply or car battery (VBAT)

- 24V/1A DC power supply
- USB-C breakout board plug (USB3.1-CM-BO-V2A or equivalent)
- Oscilloscope with four analog channels, one digital channel, and a current probe

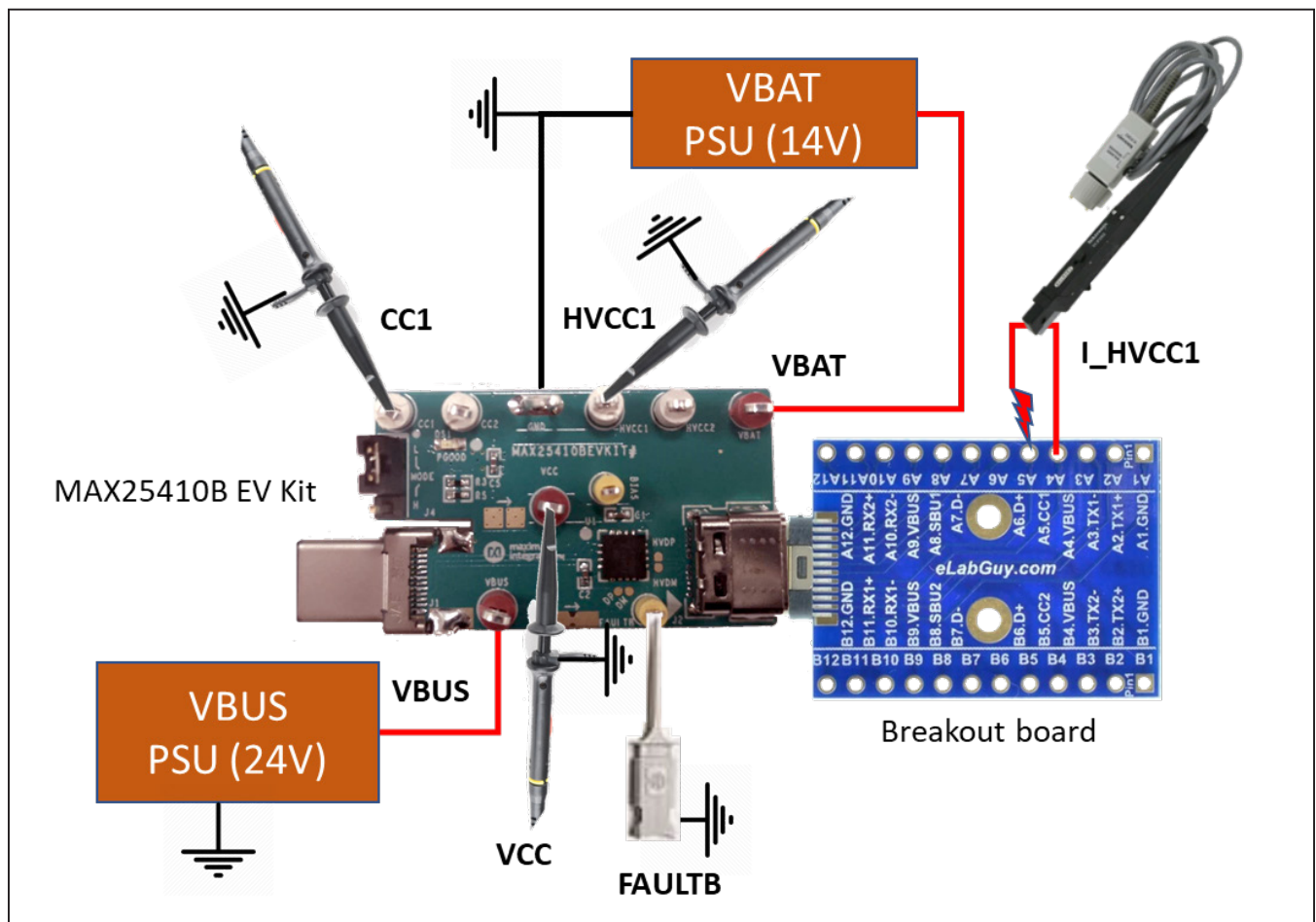

Figure 2. CC Short-to-VBUS Setup

Step-by-Step

- 1) Set the VBAT power supply to 14V output, 1A current limit. Turn the output off. Connect the negative lead to the GND test loop on the EV kit. Connect the positive lead to the VBAT test point on the EV kit.
- 2) Turn the VBAT power-supply output on. The green PGOOD LED should turn on.
- 3) Plug the USB-C breakout board plug to the EV kit receptacle.
- 4) Connect the oscilloscope probes as shown in [Figure 2](#).
- 5) Verify that VCC is at 5V and FAULT (FAULTB) is logic high.
- 6) Set the VBUS power supply to 24V output, 1A current limit. Turn the output off. Connect the negative lead to the GND test loop on the EV kit. Connect the positive lead to the VBUS test point on the EV kit.
- 7) Turn the VBUS power-supply output on.
- 8) Use a wire to short VBUS to CC1 on the breakout board. Do not short VBUS directly to the HVCC1 test point.
- 9) Observe that MAX25410B protects the low-voltage CC1 node to a safe amplitude and duration (6V and less than 50ns) thanks to its fast response to overvoltage events. Note that FAULT is being asserted to signal the USB-PD controller or host upstream. Once the overvoltage condition is removed, MAX25410B recovers automatically and release FAULT after 16ms.

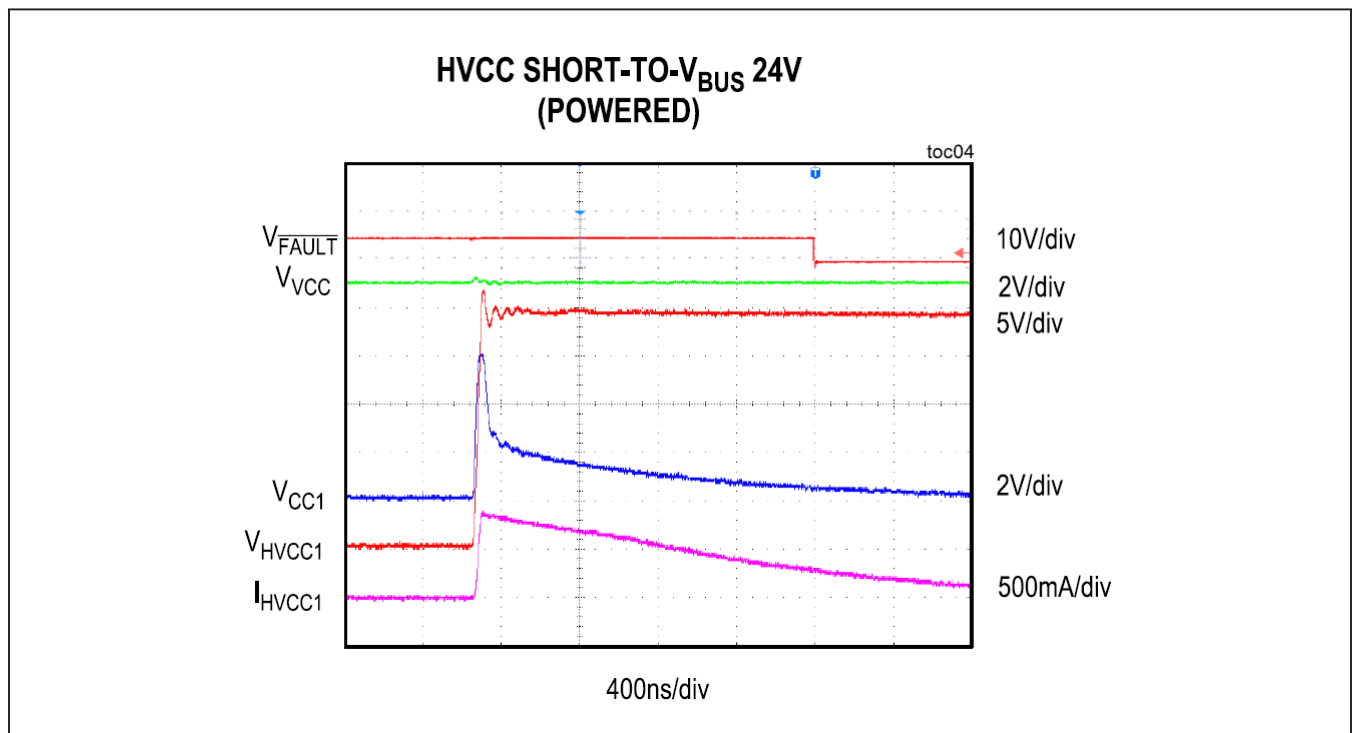

Figure 3. HVCC Short-to-VBUS Response

B) Charge Emulation - Auto-CDP

The following procedure demonstrates how to evaluate MAX25410B's auto-CDP mode.

Required Equipment

- MAX25410B EV kit
- 14V/1A DC power supply or car battery (VBAT)

- USB-C amperage meter (pluggable USBC-VAMETER or equivalent)
- USB-C device (smartphone recommended)
- Laptop with 1.5A or greater Type-C or Type-A downstream port. If Type-A, an A-to-C adapter and extension cable (1m or shorter) are needed. See the example setups shown in [Figure 4](#) and [Figure 5](#).

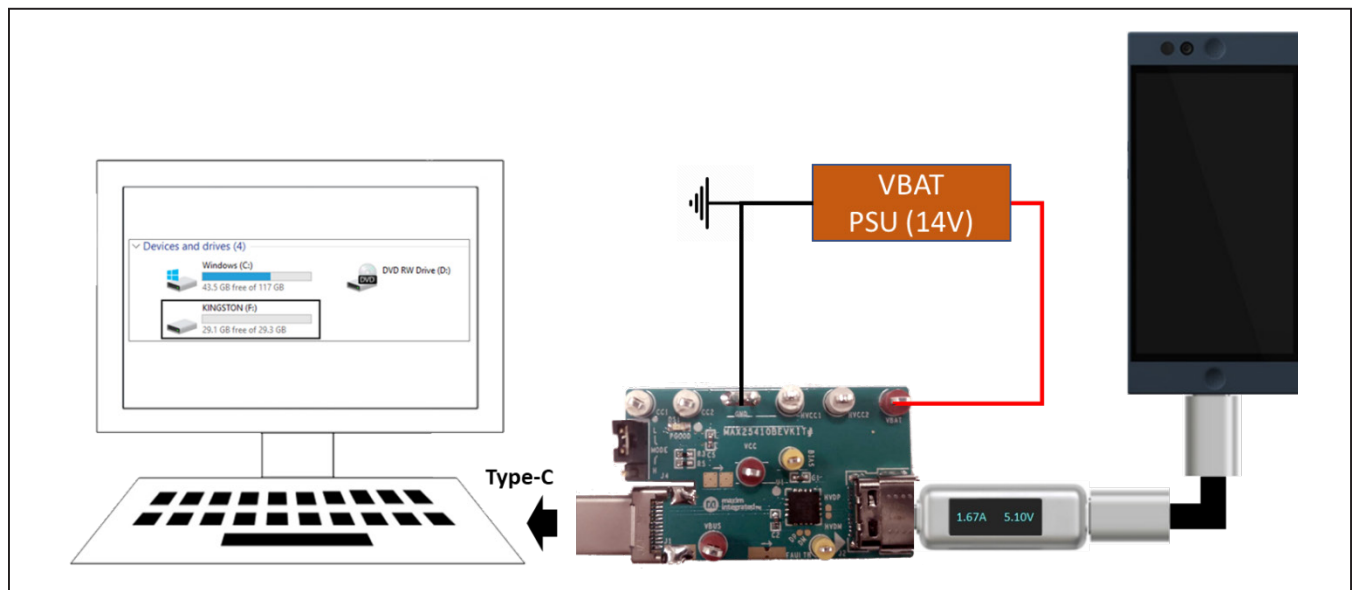

Figure 4. Auto-CDP Setup (Type-C Downstream Port)

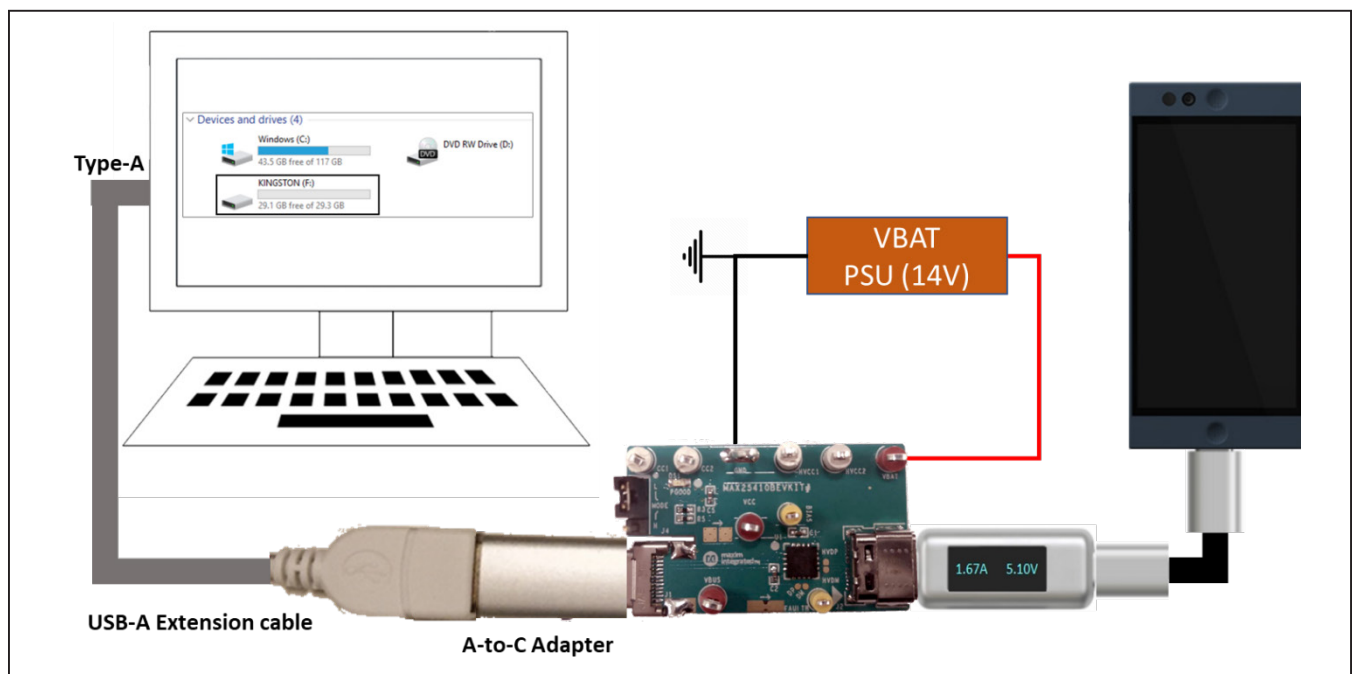

Figure 5. Auto-CDP Setup (Type-A Downstream Port)

Step-by-Step

- 1) Verify PGOOD LED is illuminated. Verify J4 is in the 'L' position (auto-CDP).
- 2) Connect the adapters, cables, and phone per the figures. Check that the phone is charging at approximately 1.5A and is recognized by the computer.
- 3) Note the CDP handshake on the HVDP and HVDM pins, which indicates to the phone that it may pull up to 1.5A of load and can enter USB high-speed data transfer after enumeration (see [Figure 6](#)).

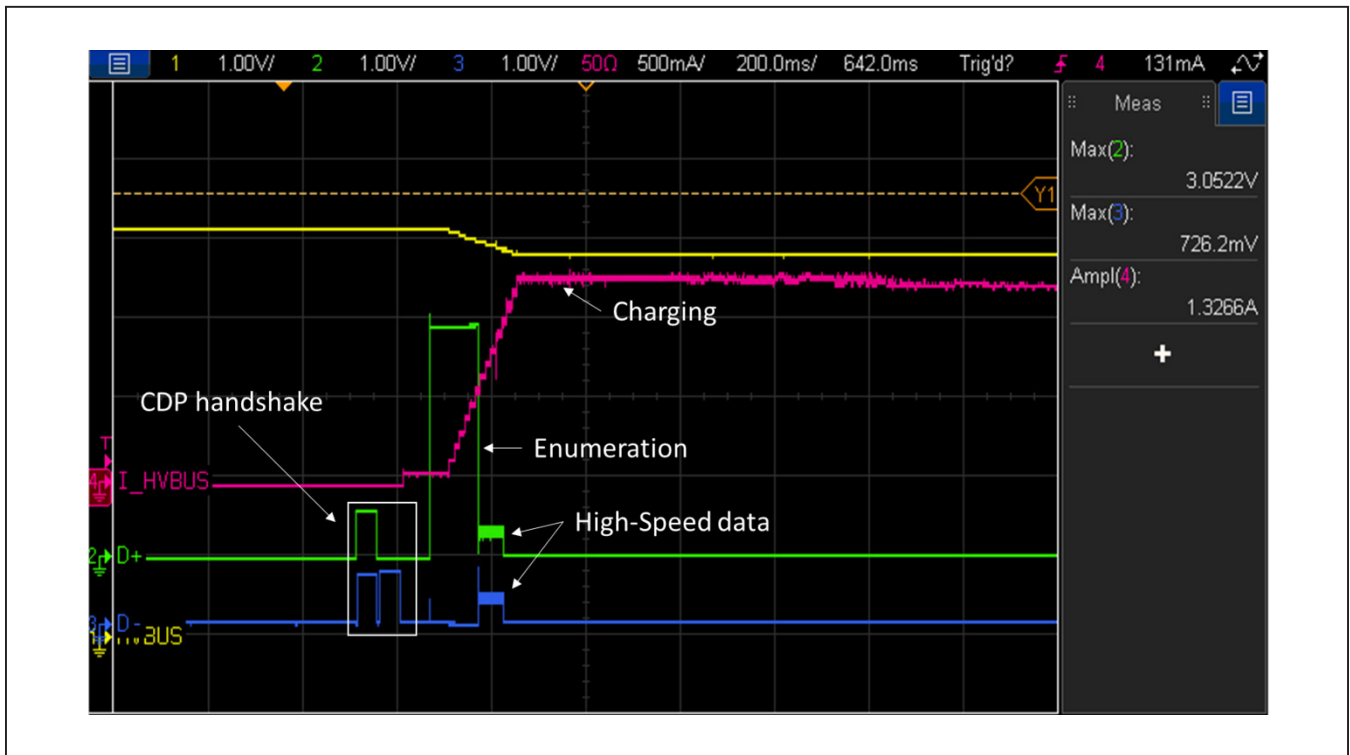

Figure 6. Auto-CDP Response

Note: Oscilloscope probes not shown on figures for simplicity.

C) Charge Emulation - Auto-DCP

The following procedure demonstrates how to evaluate MAX25410B's auto-DCP mode.

Required Equipment

- MAX25410B EV kit
- 14V/1A DC power supply or car battery (VBAT)
- USB-C amperage meter (pluggable USBC-VAMETER or equivalent)
- USB-C device (smartphone recommended)
- 1.5A or greater Type-C or Type-A downstream port. If Type-A, an A-to-C adapter and extension cable (1m or shorter) are needed. See the example setups shown in [Figure 7](#) and [Figure 8](#).

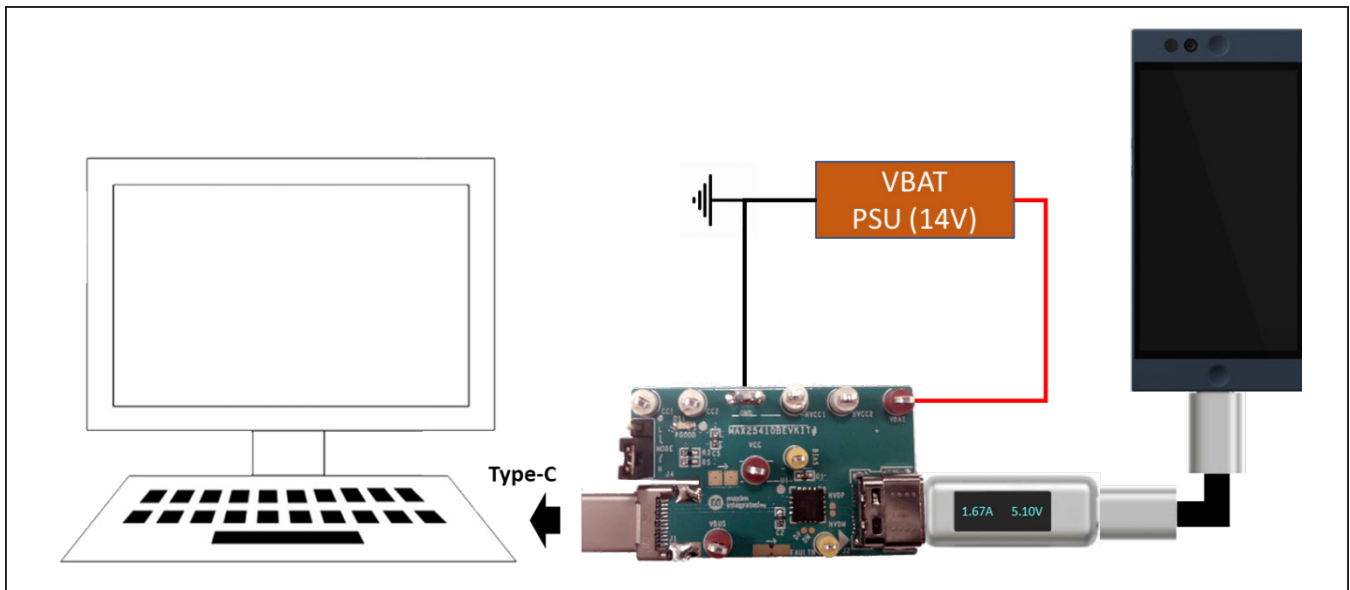

Figure 7. Auto-DCP Setup (Type-C Downstream Port)

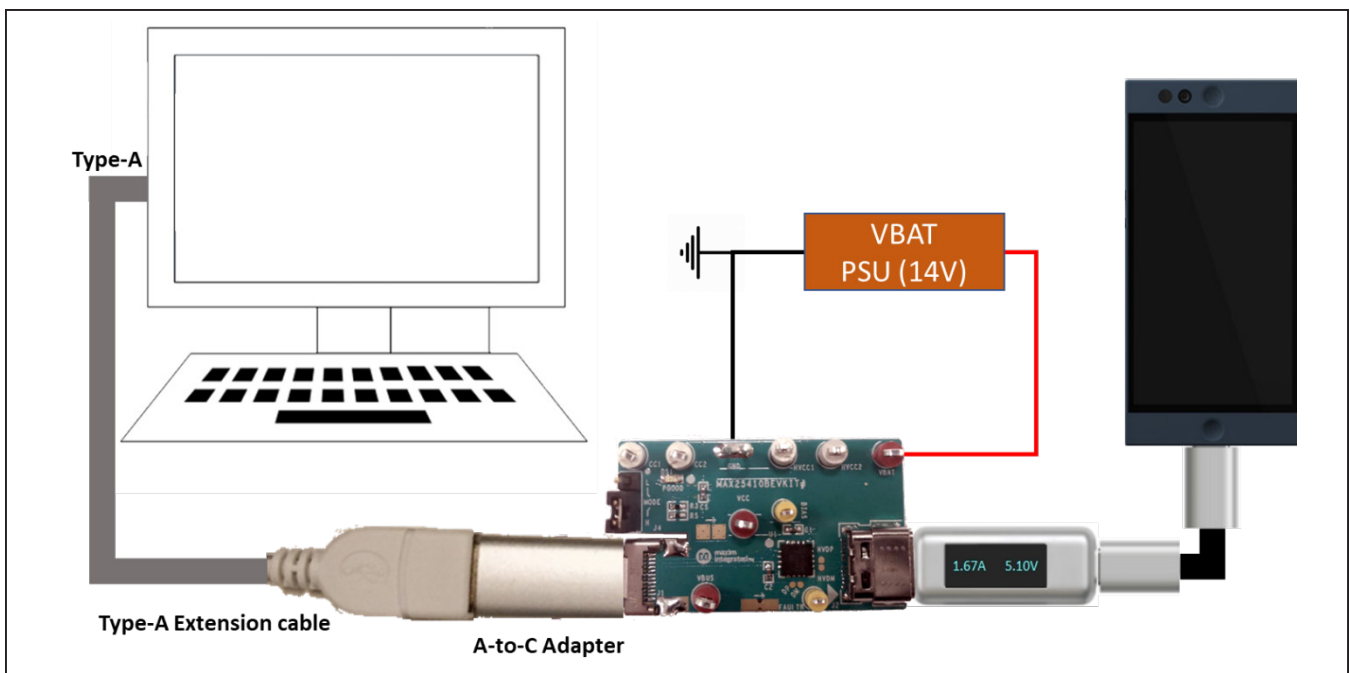

Figure 8. Auto-DCP Setup (Type-A Downstream Port)

Step-by-Step

- 1) Verify PGOOD LED is illuminated. Verify J4 is in the 'H' position (auto-DCP).
- 2) Connect the adapters, cables and phone per the figures. Check that the phone is now charging at up to 1.5A.
- 3) For an Android phone, note the DCP handshake on the HVDP and HVDM pins, which indicates to the phone that it can pull up to 1.5A of load (see [Figure 9](#)). For an Apple phone, the HVDP and HVDM stays at 2.7V and indicates to the phone it can pull up to 2.4A of current (see [Figure 10](#)).

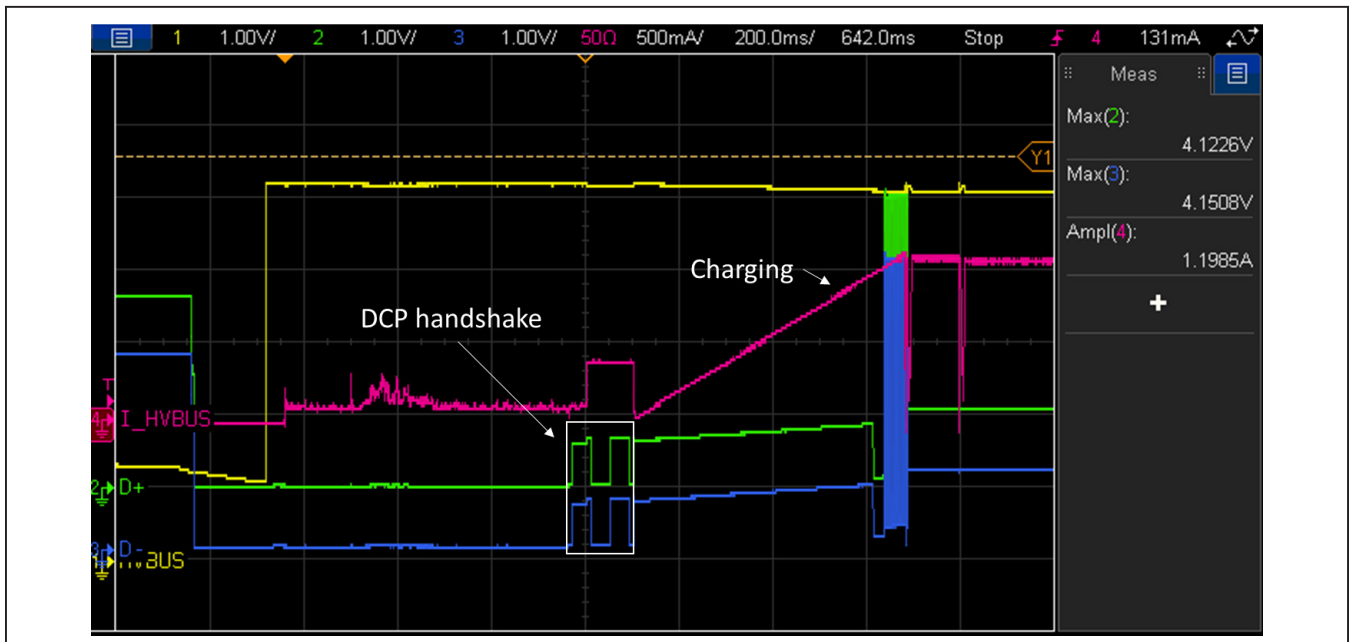

Figure 9. Auto-DCP Response with an Android Phone

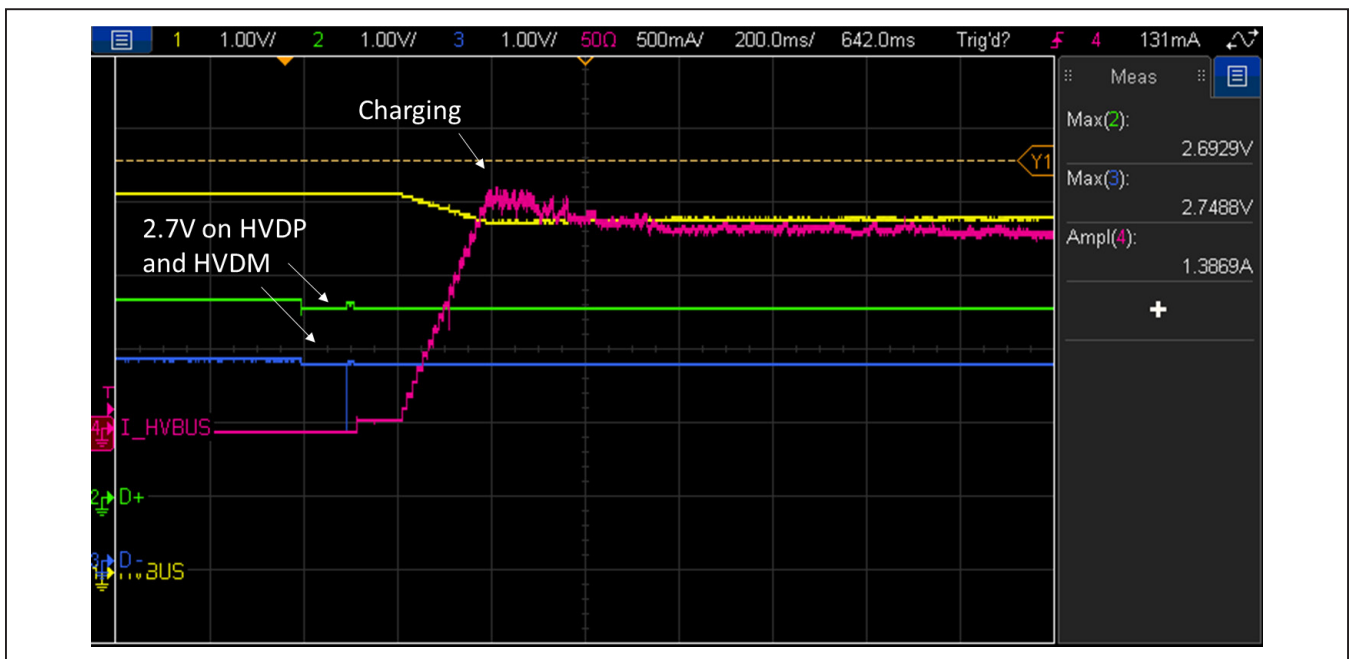

Figure 10. Auto-DCP Response with an Apple Phone

USB Type-C and Legacy Apple/Samsung/USB DCP Charging

- The amperage meter should display USB current as the device charges.
Note that for most devices, maximum charging rate occurs between approximately 20% and 80% battery level.
- Certain USB Type-C devices may prefer to follow the Type-C port current advertisement and ignore BC1.2 handshake. Source current advertisements can be any of the following:
 - 0.5A
 - 1.5A
 - 3.0A

- For non-native USB Type-C devices (Apple 30-pin/lightning and USB mini/micro-b):
 - Apple devices can consume up to 2.4A maximum.
 - BC 1.2-compatible or Samsung devices consume up to 1.5A or 2A, respectively.
- Note that some USB devices are compatible with multiple handshakes and may prefer one over the other, depending on many factors such as battery level and phone workload. The USB charging behavior can also depend on the version of software installed on the user’s device, which can change over time as updates are released.

Ordering Information

PART	TYPE
MAX25410BEVKIT#	EV Kit

#Denotes RoHS compliant.

MAX25410B EV Kit Bill of Materials

ITEM	REF_DES	DNI/DNP	QTY	MFG PART #	MANUFACTURER	VALUE	DESCRIPTION	COMMENTS
1	BIAS, FAULTB	-	2	5004	KEystone	N/A	TEST POINT; PIN DIA=0.1IN; TOTAL LENGTH=0.3IN; BOARD HOLE=0.04IN; YELLOW; PHOSPHOR BRONZE WIRE SILVER PLATE FINISH;	
2	C1, C2	-	2	C0402C105K8PAC;CC0402KRX5R6BB105	KEMET;YAGEO	1UF	CAPACITOR; SMT (0402); CERAMIC CHIP; 1UF; 10V; TOL=10%; TG=-55 DEGC TO +85 DEGC; TC=X5R	
3	C3	-	1	C0603C105K4RAC;GRM188R71C105KA12; C1608X7R1C105K080AC;EMK107B7105KA; CGA3E1X7R1C105K080AC;0603YC105KAT2A	KEMET;MURATA;TDK; TAIYO YUDEN;TDK;AVX	1UF	CAPACITOR; SMT (0603); CERAMIC CHIP; 1UF; 16V; TOL=10%; MODEL=; TG=-55 DEGC TO +125 DEGC; TC=X7R	
4	C4	-	1	C1206C475K3RAC	KEMET	4.7UF	CAPACITOR;1206; 4.7UF;25V; 10%;; X7R--55DEGC TO +125DEGC	
5	C5	-	1	C1005X7R1H104K050BB;GRM155R71H104KE14; C1005X7R1H104K050BE;UMK105B7104KV-FR	TDK;MURATA;TDK;TAIYO YUDEN	0.1UF	CAPACITOR; SMT (0402); CERAMIC CHIP; 0.1UF; 50V; TOL=10%; TG=-55 DEGC TO +125 DEGC; TC=X7R	
6	C6	-	1	C2012X7S1A226M125AC	TDK	22UF	CAP; SMT (0805); 22UF; 20%; 10V; X7S; CERAMIC CHIP	
7	C9	-	1	GRM32ER71E226KE15; CL32B226KAJNFN; CL32B226KAJNNW;TMK325B7226KM	MURATA;SAMSUNG ELECTRO-MECHANICS;TA	22UF	CAPACITOR; SMT (1210); CERAMIC CHIP; 22UF; 25V; TOL=10%; TG=-55 DEGC TO +125 DEGC; TC=X7R	
8	CC1, CC2, HVCC1, HVCC2	-	4	5007	KEystone	N/A	TEST POINT; PIN DIA=0.125IN; TOTAL LENGTH=0.35IN; BOARD HOLE=0.063IN; WHITE; PHOSPHOR BRONZE WIRE SILVER PLATE FINISH	
9	D1	-	1	SE10FD-M3/H	Vishay Semiconductors	SE10FD-M3/H	DIODE; RECT; SMT (SOD-123F); PIV=200V; IF=1A;	
10	DM, DP, HVDM, HVDP	-	4	ANY	ANY	MICRO_TP	TEST POINT; MICRO; TP; PAD DIA: 0.8128 MM(32MILS) SOLDERMASK: 0.9144 MM(36MILS) THERMAL RELIEF/ANTIPAD: 1.574MM(62MILS); SMD	
11	DS1	-	1	APT1608LZGCK	KINGBRIGHT	APT1608LZGCK	DIODE; LED; GREEN WATER CLEAR; GREEN; SMT (0603); VF=2.65V; IF=0.002A	
12	GND	-	1	5020	KEystone	MAXIMPAD	EVKIT PART - MAXIM PAD; TEST POINT; PIN DIA=0.094IN; TOTAL LENGTH=0.350IN; BOARD HOLE=0.040IN; NONE; PHOSPHOR BRONZE WIRE SILVER PLATE FINISH;	
13	J1	-	1	DX07P024MJ1	JAE ELECTRONIC INDUSTRY	DX07P024MJ1	CONNECTOR; FEMALE; SMT; USB 3.1; SUPERSPEED; RIGHT ANGLE; 24PINS	
14	J2	-	1	2012670005	MOLEX	2012670005	CONNECTOR; FEMALE; SMT; USB TYPE C RECEPTACLE; RIGHT ANGLE; 24PINS	
15	J4	-	1	TSW-103-23-G-S	SAMTEC	TSW-103-23-G-S	CONNECTOR; THROUGH HOLE; SINGLE ROW; STRAIGHT; 3PINS; -55 DEGC TO +125 DEGC	
16	L1	-	1	LQM21PZ4R7MGR	MURATA	4.7UH	INDUCTOR; SMT (0805); FERRITE; 4.7UH; 20%; 0.8A	
17	R1	-	1	CRCW0402100KJN	VISHAY DALE	100K	RESISTOR; 0402; 100K OHM; 5%; 200PPM; 0.063W; THICK FILM	
18	R2	-	1	ERJ-2RKF5102	PANASONIC	51K	RESISTOR; 0402; 51K OHM; 1%; 100PPM; 0.1W; THICK FILM	
19	R3	-	1	CRCW040240K2FK	VISHAY DALE	40.2K	RESISTOR; 0402; 40.2K OHM; 1%; 100PPM; 0.063W; THICK FILM	
20	R4, R5	-	2	ERJ-2RKF1002	PANASONIC	10K	RESISTOR; 0402; 10K OHM; 1%; 100PPM; 0.10W; THICK FILM	
21	R6	-	1	CRCW06030000Z0	VISHAY DALE	0	RESISTOR; 0603; 0 OHM; 0%; JUMPER; 0.1W; THICK FILM	
22	SHUNT_J4	-	1	QPC02SXGN-RC	SULLINS ELECTRONICS CORP.	QPC02SXGN-RC	CONNECTOR; FEMALE; 0.100IN CC; OPEN TOP; JUMPER; STRAIGHT; 2PINS	
23	U1	-	1	MAX25410BGTE/V+	MAXIM	MAX25410BGTE/V+	EVKIT PART - IC; PROT; AUTOMOTIVE USB POWER DELIVERY PORT PROTECTION/PROTECTOR; PACKAGE OUTLINE DRAWING: 21-0139; PACKAGE CODE: T1644+4C; LAND PATTERN: 90-0070; TQFN16-EP	
24	U2	-	1	MAX20075ATCA	MAXIM	MAX20075ATCA	IC; CONV; 36V 1A MINI BUCK CONVERTER WITH 5UA IQ; TDFN12-EP	
25	VBAT, VBUS, VCC	-	3	5005	KEystone	N/A	TEST POINT; PIN DIA=0.125IN; TOTAL LENGTH=0.35IN; BOARD HOLE=0.063IN; RED; PHOSPHOR BRONZE WIRE SILVER PLATE FINISH;	
26	PCB	-	1	MAX25410B	MAXIM	PCB	PCB-MAX25410B	
27	C7, C8	DNP	0	C0402C0G500-391JNE;GRM1555C1H391JA01; CGA2B2C0G1H391J050BA	VENKEL LTD.;MURATA;TDK	390PF	CAPACITOR; SMT (0402); CERAMIC CHIP; 390PF; 50V; TOL=5%; MODEL=; TG=-55 DEGC TO +125 DEGC; TC=C0G	
TOTAL			37					

MAX25410B EV Kit Schematic

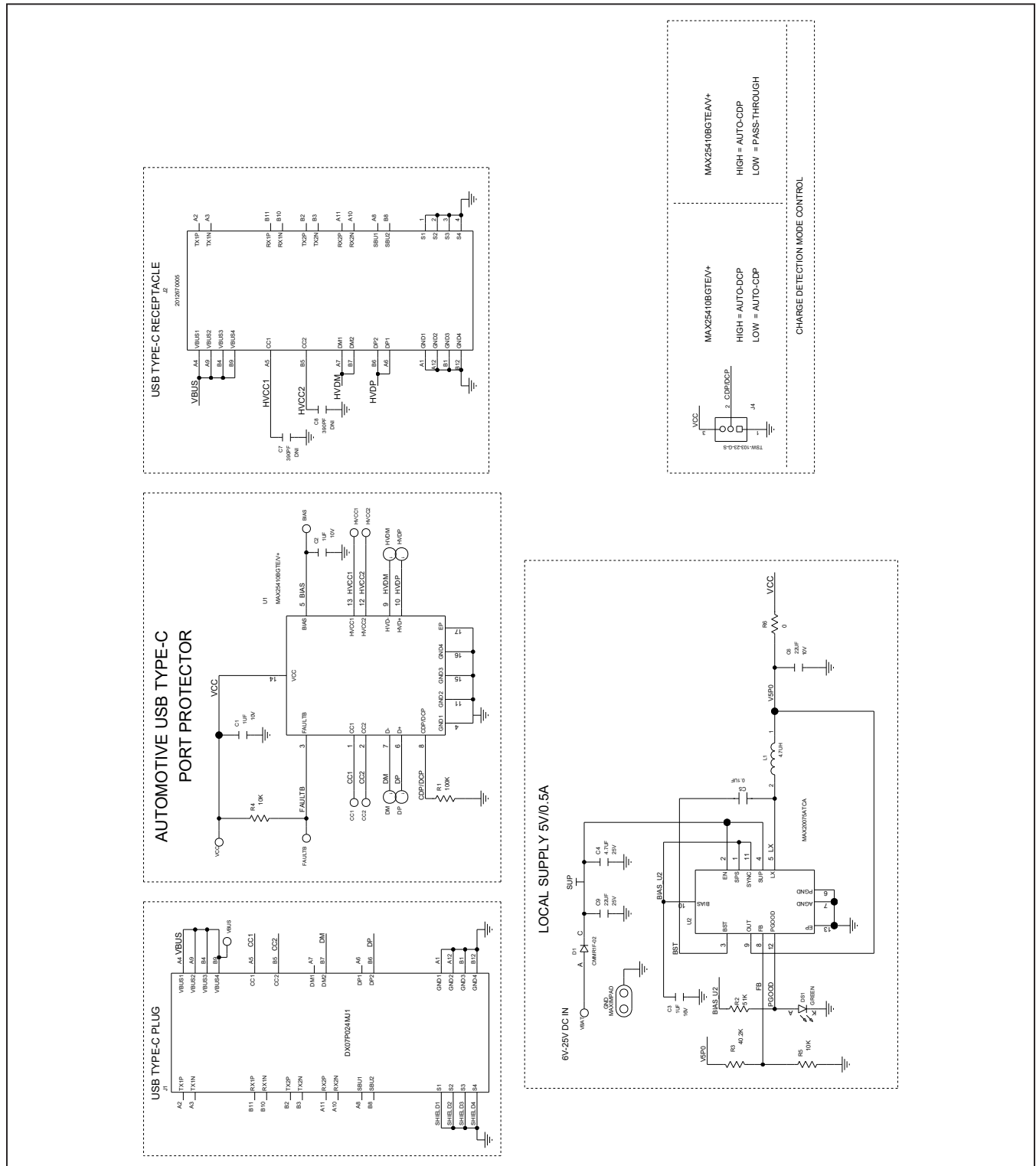

MAX25410B EV Kit PCB Layouts

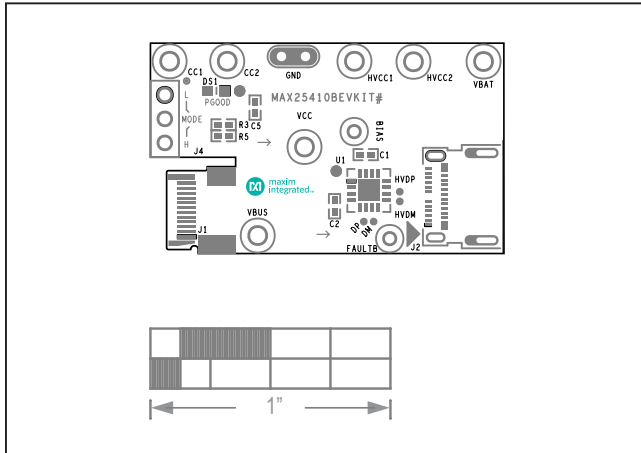

MAX25410B EV Kit PCB Layout—Top Silkscreen

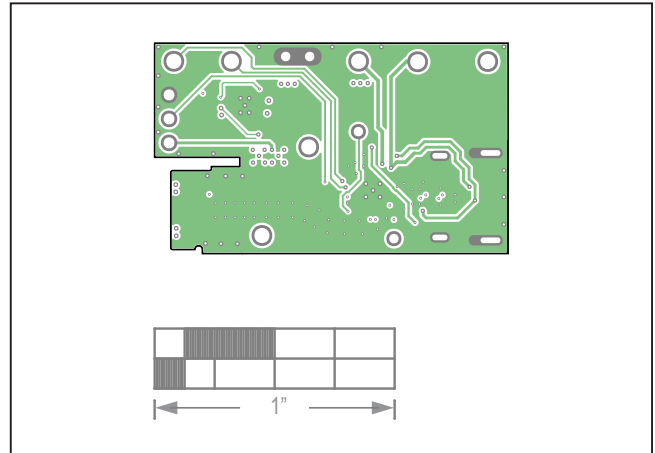

MAX25410B EV Kit PCB Layout—Layer 3

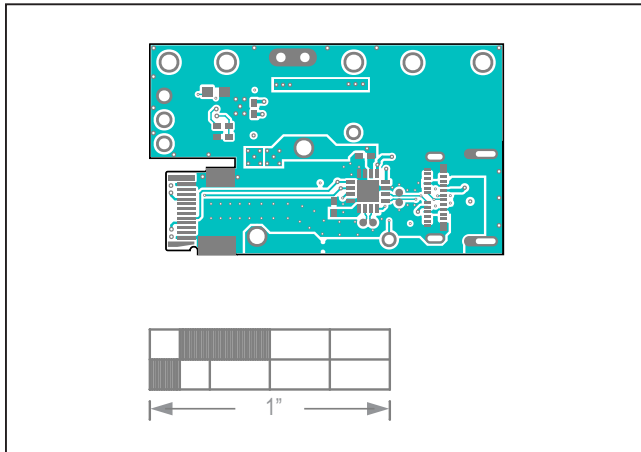

MAX25410B EV Kit PCB Layout—Top Layer

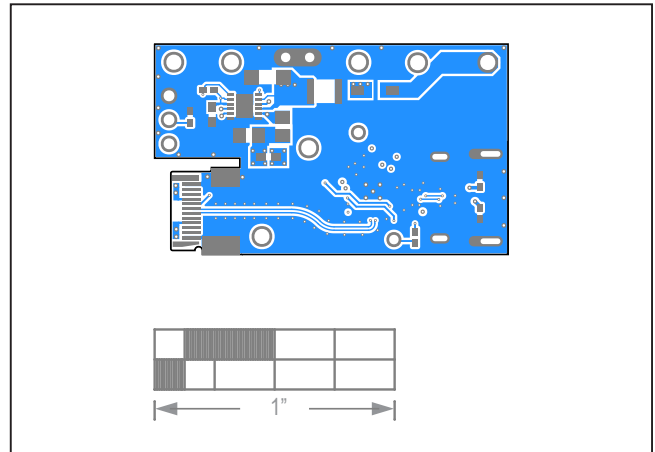

MAX25410B EV Kit PCB Layout—Bottom Layer

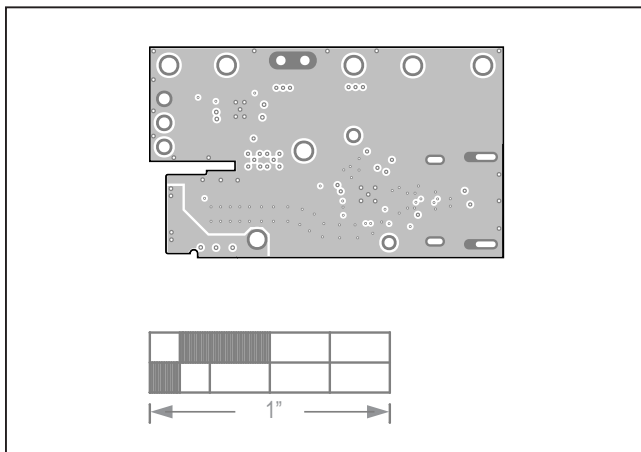

MAX25410B EV Kit PCB Layout—Layer 2

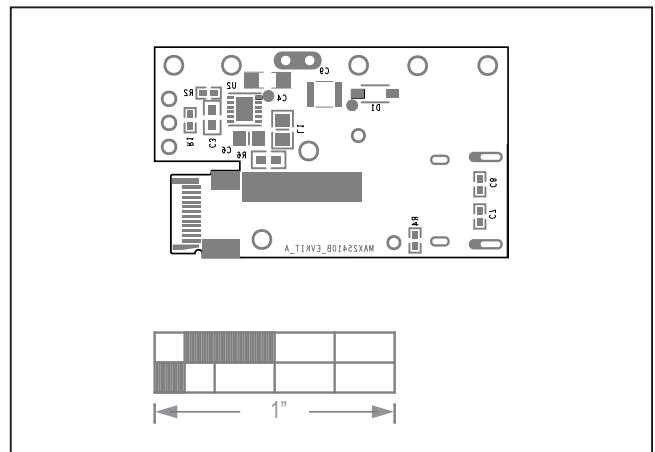

MAX25410B EV Kit PCB Layout—Bottom Silkscreen

Revision History

REVISION NUMBER	REVISION DATE	DESCRIPTION	PAGES CHANGED
0	7/20	Release for intro.	—
1	8/20	Change part number in header (Evaluates) to root part number.	All

For pricing, delivery, and ordering information, please visit Maxim Integrated's online storefront at <https://www.maximintegrated.com/en/storefront/storefront.html>.

Maxim Integrated cannot assume responsibility for use of any circuitry other than circuitry entirely embodied in a Maxim Integrated product. No circuit patent licenses are implied. Maxim Integrated reserves the right to change the circuitry and specifications without notice at any time.

X-ON Electronics

Largest Supplier of Electrical and Electronic Components

Click to view similar products for [Interface Development Tools](#) category:

Click to view products by [Maxim](#) manufacturer:

Other Similar products are found below :

[ADP5585CP-EVALZ](#) [CHA2066-99F](#) [AS8650-DB](#) [MLX80104 TESTINTERFACE](#) [416100120-3](#) [XR18910ILEVB](#) [XR21B1421IL28-0A-EVB](#) [TW-DONGLE-USB](#) [EVAL-ADM2491EEBZ](#) [MAXREFDES23DB#](#) [MAX13235EEVKIT](#) [DFR0257](#) [XR22404CG28EVB](#) [ZLR964122L](#) [ZLR88822L](#) [EVK-U23-01S](#) [EVK-W262U-00](#) [DC327A](#) [PIM511](#) [PIM536](#) [PIM517](#) [DEV-17512](#) [STR-FUSB3307MPX-PPS-GEVK](#) [MAXREFDES177#](#) [EVAL-ADM2567EEBZ](#) [ZSSC3240KIT](#) [MAX9121EVKIT](#) [PIM532](#) [ZSC31010KITV2P1](#) [UMFT4233HPEV](#) [LVDS-18B-EVK](#) [XR20M1170G16-0B-EB](#) [XR20M1170G24-0B-EB](#) [XR20M1172G28-0A-EB](#) [XR20M1172G28-0B-EB](#) [SI871XSOIC8-KIT](#) [1764](#) [1833](#) [1862](#) [EVB-USB82514](#) [ATA6628-EK](#) [ATA6631-EK](#) [EVAL-CN0313-SDPZ](#) [2264](#) [MCP23X17EV](#) [PS081-EVA-HR MODULE](#) [237](#) [SMA2RJ45EVK/NOPB](#) [FR12-0002](#) [MAFR-000455-001](#)