

MAX25410 Evaluation Kit

Evaluates: MAX25410

General Description

The MAX25410 evaluation kit (EV kit) demonstrates Maxim's automotive USB-PD port protector with integrated V_{CONN} switch, host charger adapter emulation, system-level ESD, short-to- V_{BUS} protection, and short-to-battery protection.

The EV kit is designed to be plugged into any USB 2.0 Type-C port, effectively providing a new fully protected Type-C port. The EV kit only requires one external power-supply source to operate. Protection is always maintained, whether or not the input supply is present.

The MAX25410 can be used to protect any USB 2.0 interface and USB-PD controller, but also provides a Type-C compliant 1W V_{CONN} switch to power E-marked cables. Simply connect the V_{CONN} enable input pins to a USB-PD controller to evaluate MAX25410 in a given system. Additionally, MAX25410 automatic fault recovery enables a seamless user experience.

The MAX25410 also features integrated host-charger port-detection circuitry that adheres to the USB-IF BC1.2 battery-charging specification, Apple® iPod/iPhone/iPad and Samsung® 2.0A, and Chinese Telecommunication Industry Standard YD/T 1591-2009 charge emulation.

The EV kit is populated with a MAX25410AGTE/V+ (variant with active-low V_{CONN} enable, auto-CDP and auto-DCP/Apple 2.4A host-charger emulation modes). Other variants can be used by simply replacing the IC on the EV kit.

Ordering Information appears at end of data sheet.

Features and Benefits

- USB Type-C CC1/CC2 Protection Switches
- Integrated 550m Ω V_{CONN} FETs with 250mA Overcurrent Protection
- USB 2.0 D+/D- Protection Switches with 1GHz Bandwidth
- 24V CC and USB 2.0 Protection against Short-to- V_{BUS}
- Automatic Fault Detection and Recovery with Industry-Compliant Reset Timings
- Integrated BC1.2, Apple and Samsung Charge Emulation
 - Supports BC1.2 CDP and DCP Modes
 - Apple 2.4A, 1.0A
 - Samsung 2.0A
 - China YD/T 1591-2009 Charging Specification
 - Compatible with USB On-the-Go Specification and Apple CarPlay
- High ESD Protection (HVD+/HVD-, HVCC1/HVCC2)
 - ± 2 kV Human Body Model
 - ± 15 kV ISO 10605 Air Gap
 - ± 8 kV ISO 10605 Contact
 - ± 15 kV IEC 61000-4-2 Air Gap
 - ± 8 kV IEC 61000-4-2 Contact
- Proven PCB Layout

Box Content

- MAX25410 EV Kit Fully Assembled and Tested

Apple, iPod, iPhone, and iPad are registered trademarks of Apple Inc.
Samsung is a registered trademark of Samsung Electronics Co., Ltd.

Getting Started

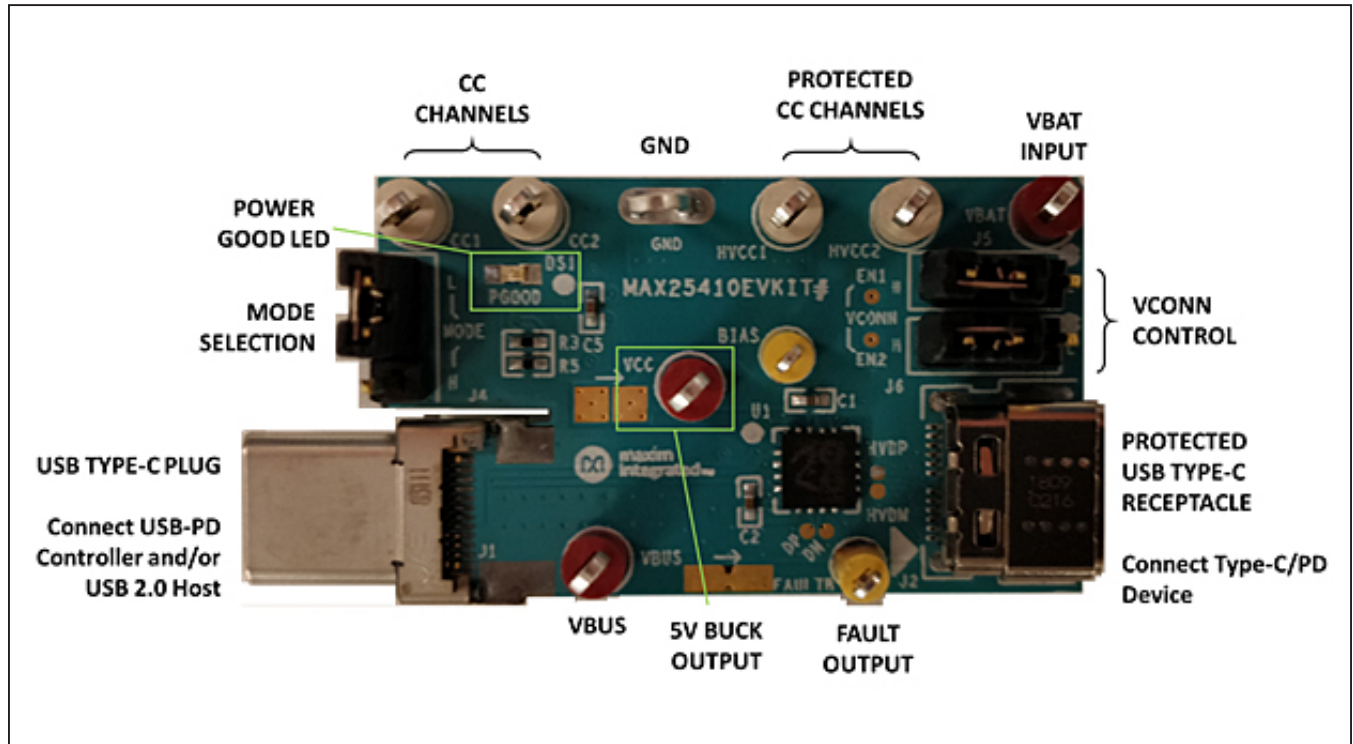

Figure 1. EV Kit Interfaces

Table 1. Jumper List

JUMPER	FUNCTION	CONTROL	
J4	Charge Mode Selection	Low: auto-CDP	High: auto-DCP/Apple 2.4A
J5	VCONN EN1 Control	See VCONN switch-enable table. Manual Control: Set jumper to H or L Automatic Control: Connect enable input to USB-PD Controller	
J6	VCONN EN2 Control		

Note: This table applies to the default IC installed on the EV kit: MAX25410AGTE/V+. To evaluate VCONN active-high and/or USB data pass-through mode, replace U1 with the required IC. Please refer to the *Ordering Table* in the MAX25410 data sheet.

Table 2. Test-Point List

TESTPOINT	FUNCTION
CC1, CC2	Low-voltage, unprotected CC channels from upstream USB-PD controller. Input to the MAX25410's CC pass-through switches.
HVCC1, HVCC2	Protected CC channels and V _{CONN} outputs. The CC pass-through switches are always closed whenever PGOOD is illuminated and no fault has occurred. Test points for monitoring only.
V _{BUS}	Upstream V _{BUS} . Can also be forced externally if the Type-C plug is left unconnected.
FAULT	Fault indicator output - See <i>Fault Table</i> in the MAX25410 data sheet
V _{CC}	Regulated 5V/0.6A output from MAX20075 Automotive Buck Converter. Provides power to MAX25410.
BIAS	Internal MAX25410 LDO output. Test point for monitoring only.
V _{BAT}	Main EV kit input power. Connect to 14V power supply or car battery.
GND	Ground. Connect power supply negative terminal and all probe references to the GND test point.
DP/DM	Test pads to monitor low-voltage USB 2.0 D+/D- signals from upstream transceiver. Note: These signals are routed with 90Ω differential impedance.
HVDP/HVDM	Test pads to monitor high-voltage-protected USB 2.0 signals and charge emulation. Note: These signals are routed with 90Ω differential impedance.

Important: High-voltage events (ie. short-to-V_{BUS}) must be applied only through the Type-C receptacle and not directly to these test points in order to avoid damage to the ICs.

Table 3. V_{CONN} Switch-Enable Table (Default IC on EV Kit)

PGOOD	V _{CONN_EN1}	V _{CONN_EN2}	CC1/CC2 PASS-THROUGH	HVCC1 V _{CONN} SWITCH	HVCC2 V _{CONN} SWITCH
No	x	x	Off	Off	
Yes	High		On	Off	
	Low	High		On	Off
	High	Low		Off	On
	Low			Off	

A) CC Short-to- V_{BUS} Protection

The following procedure demonstrates MAX25410's response to a CC short-to- V_{BUS} event through the USB-C connector.

Required Equipment

- MAX25410 EV kit
- 14V/1A DC power supply or car battery (V_{BAT})
- 24V/1A DC power supply
- USB-C breakout board plug (USB3.1-CM-BO-V2A or equivalent)
- Oscilloscope with four analog channels, one digital channel, and a current probe

Step-by-step

- 1) Verify that both V_{CONN} selection jumpers are set to 'H' (no V_{CONN} is being sourced).
- 2) Set the V_{BAT} power supply to 14V output, 1A current limit. Turn the output off. Connect the negative lead to the GND test loop on the EV kit. Connect the positive lead to the V_{BAT} test point on the EV kit.
- 3) Turn the V_{BAT} power-supply output on. The green PGOOD LED should turn on.

- 4) Plug the USB-C breakout board plug into the EV kit receptacle.
- 5) Connect the oscilloscope probes as shown in [Figure 2](#).
- 6) Verify that V_{CC} is at 5.0V and \overline{FAULT} is logic-high.
- 7) Set the V_{BUS} power supply to 24V output, 1A current limit. Turn the output off. Connect the negative lead to the GND test loop on the EV kit. Connect the positive lead to the V_{BUS} test point on the EV kit.
- 8) Turn the V_{BUS} power-supply output on.
- 9) Use a wire to short V_{BUS} to CC1 on the breakout board. Do not short V_{BUS} directly to the HVCC1 test point.
- 10) Observe that MAX25410 protects the low-voltage CC1 node to a safe amplitude and duration (6V and less than 50ns) thanks to its fast response to over-voltage events. Note that \overline{FAULT} is being asserted to signal the USB-PD controller. Once the overvoltage condition is removed, MAX25410 will recover automatically and release \overline{FAULT} after 16ms.

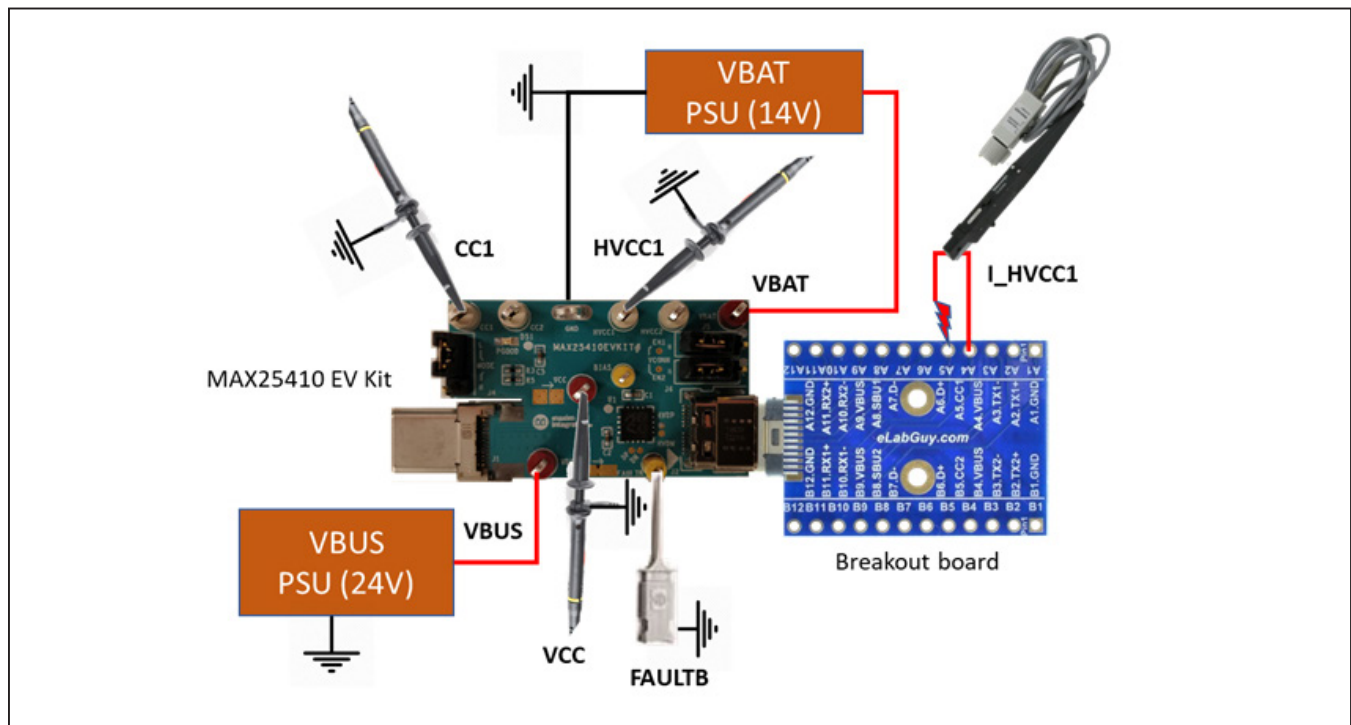

Figure 2. CC Short-to- V_{BUS} Setup

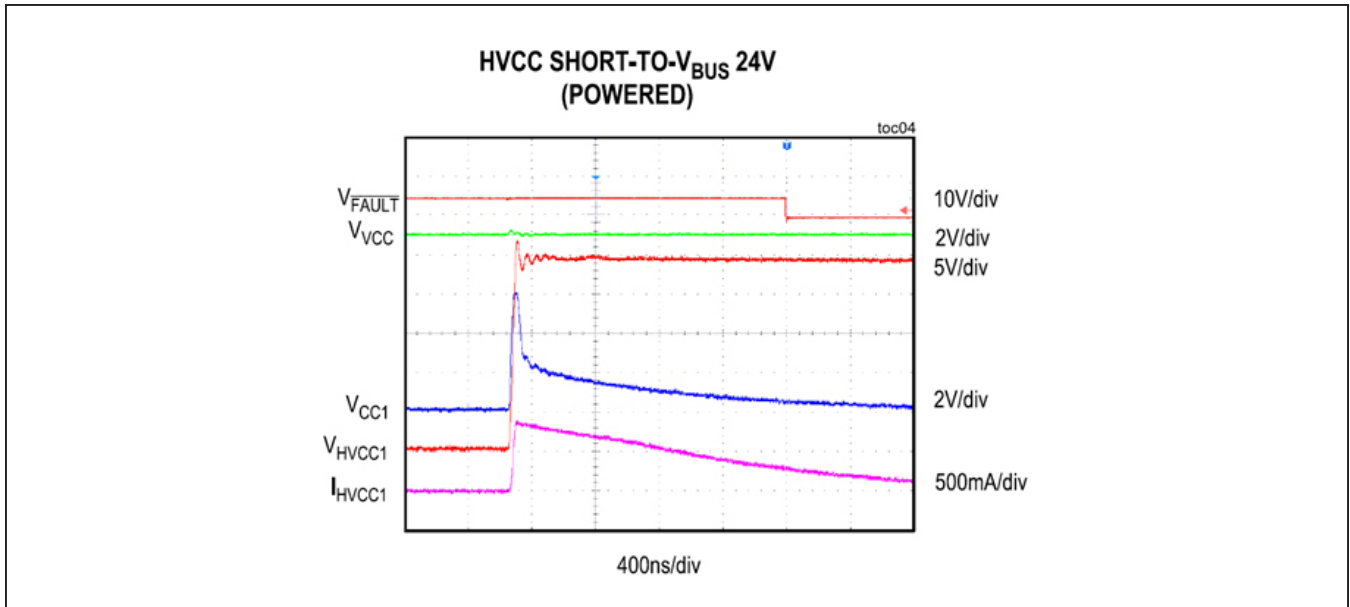

Figure 3. HVCC Short-to-V_{BUS} Response

B) V_{CONN} Switch Evaluation and Short-to-Ground

The following procedure demonstrates how to enable/disable V_{CONN} and MAX25410's response to a V_{CONN} short-to-ground event.

Required Equipment

- MAX25410 EV kit
- 14V/1A DC power supply or car battery (V_{BAT})
- USB-C breakout board plug (USB3.1-CM-BO-V2A or equivalent)
- Oscilloscope with four analog channels, one digital channel, and a current probe

Step-by-step

- 1) Verify that PGOOD LED is on and both V_{CONN} selection jumpers are set to 'H' (no V_{CONN} is being sourced).
- 2) Plug the USB-C breakout board plug into the EV kit receptacle.

- 3) Connect the oscilloscope probes as shown in [Figure 2](#).
- 4) Verify that V_{CC} is at 5.0V and $\overline{\text{FAULT}}$ is logic-high.
- 5) Set the J5 jumper to 'L' to enable V_{CONN} on HVCC1. Verify that HVCC1 is now at 5.0V.
- 6) Use a wire to short GND to CC1 on the breakout board.
- 7) Observe the response. MAX25410 prevents the V_{CC} node from drooping to less than 4.65V thanks to its fast UV comparator. Note that $\overline{\text{FAULT}}$ is being asserted to signal the USB-PD controller. To avoid dissipating heat unnecessarily, MAX25410 does not restart V_{CONN} unless the short-to-ground condition is removed and 16ms have expired.

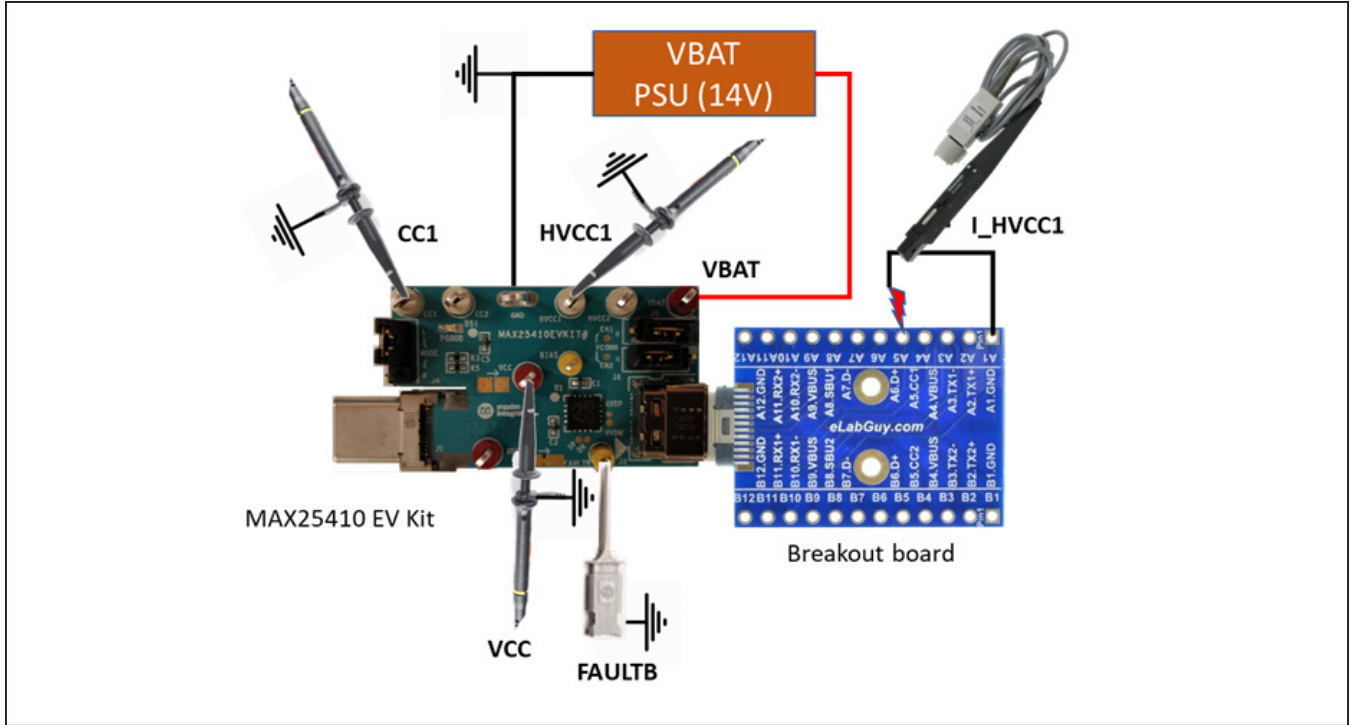

Figure 4. VCONN Short-to-Ground Setup

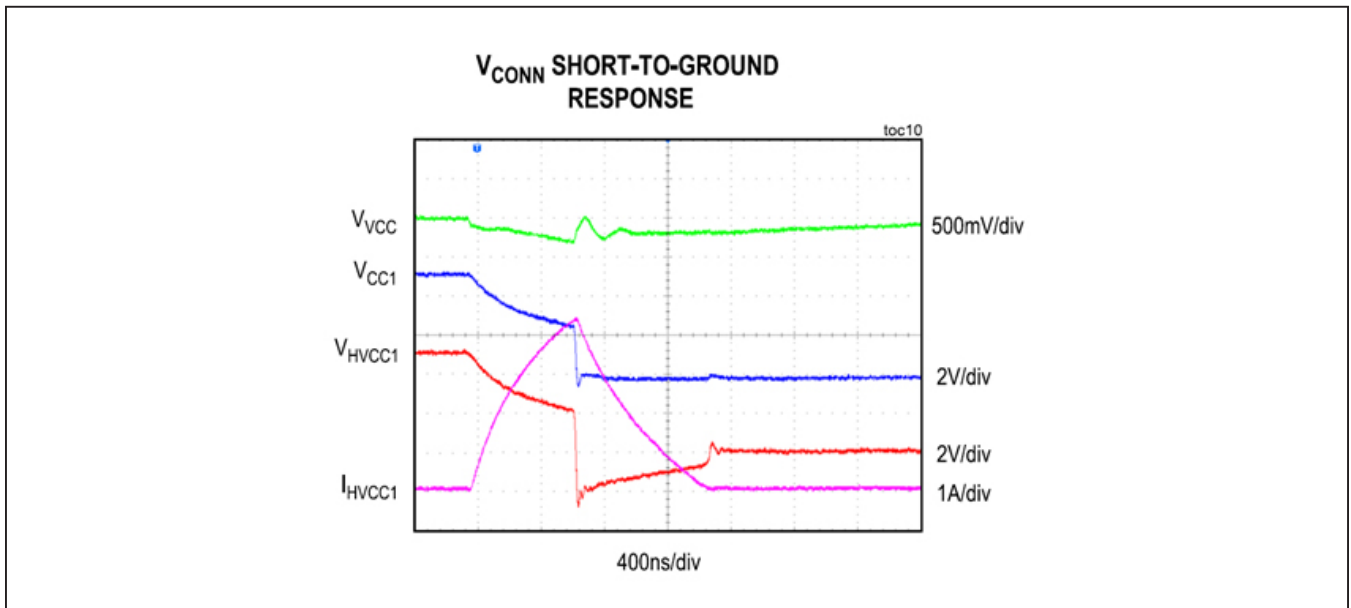

Figure 5. VCONN Short-to-Ground Response

C) Automatic V_{CONN} Control

The following procedure demonstrates how to connect the EV kit to an external USB-PD controller.

Required Equipment

- MAX25410 EV kit
- 14V/1A DC power supply or car battery (V_{BAT})
- 2 Dupont jumper wires female-female: V_{CONN_EN1}, V_{CONN_EN2}
- Any USB-PD controller with two spare 3.3V or 5.0V active-low logic level outputs. For active-high, swap U1 with MAX25410GTE/V+.

Step-by-step Procedure

- 1) Verify that the PGOOD LED is illuminated, and remove both V_{CONN} jumper shorts on J5 and J6.
- 2) Connect Dupont wires to the EV kit and to the USB controller V_{CONN} enable signals as shown in [Figure 2](#).
- 3) Connect the MAX25410 EV kit to the USB-PD development kit.
- 4) The MAX25410 will now provide V_{CONN} automatically every time the PD-controller detects an R_d and an R_a on the CC channels.

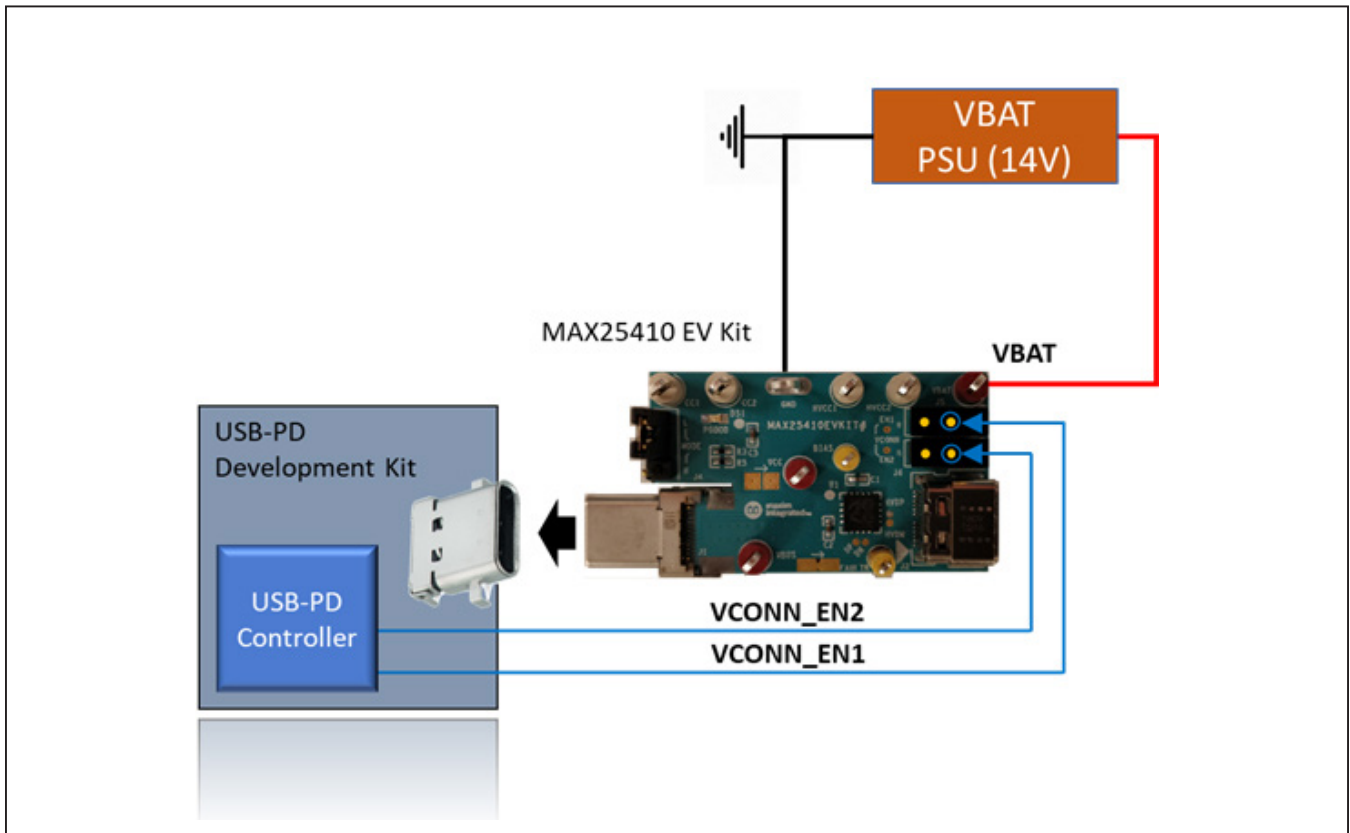

Figure 6. External V_{CONN} Control

D) Charge Emulation - Auto-CDP

The following procedure demonstrates how to evaluate MAX25410's auto-CDP mode.

Required Equipment

- MAX25410 EV kit
- 14V/1A DC power supply or car battery (V_{BAT})

- USB-C amperage meter (pluggable USBC-VAMETER or equivalent)
- USB-C device (smartphone recommended)
- Laptop with a 1.5A or greater Type-C or Type-A downstream port. If Type-A, an A-to-C adapter and extension cable (1m or shorter) are needed. See the two example setups in [Figure 7](#) and [Figure 8](#).

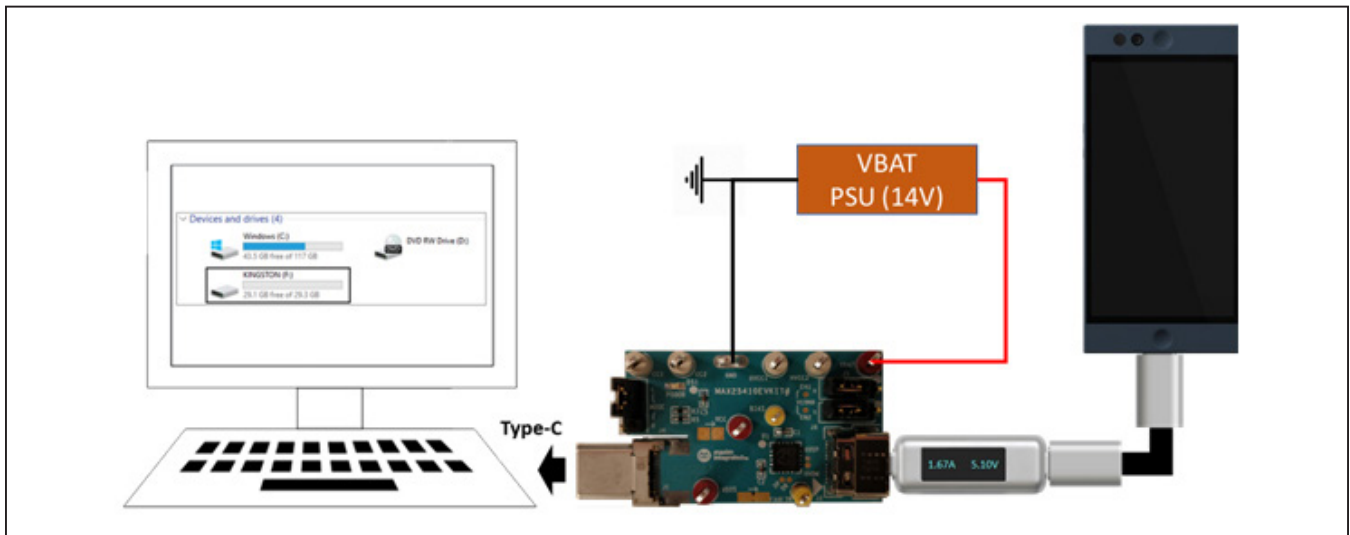

Figure 7. Auto-CDP Setup (Type-C Downstream Port)

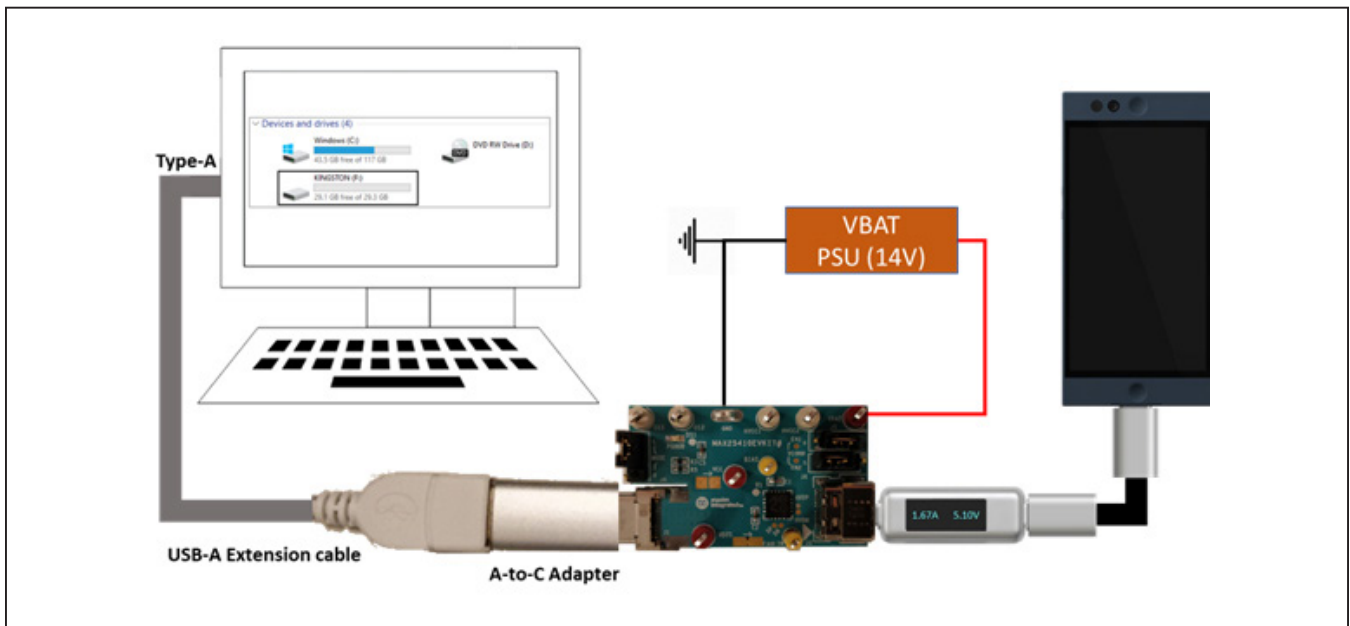

Figure 8. Auto-CDP Setup (Type-A Downstream Port)

Step-by-step

- 1) Verify that the PGOOD LED is illuminated. Verify that J4 is in the 'L' position (auto-CDP).
- 2) Connect the adapters, cables, and phone per the figures. Check that the phone is charging at approximately 1.5A and is recognized by the computer.
- 3) Note the CDP handshake on the HVDP and HVDM pins, which indicates to the phone that it may pull up to 1.5A of load and can enter USB high-speed data transfer after enumeration (see [Figure 9](#)).

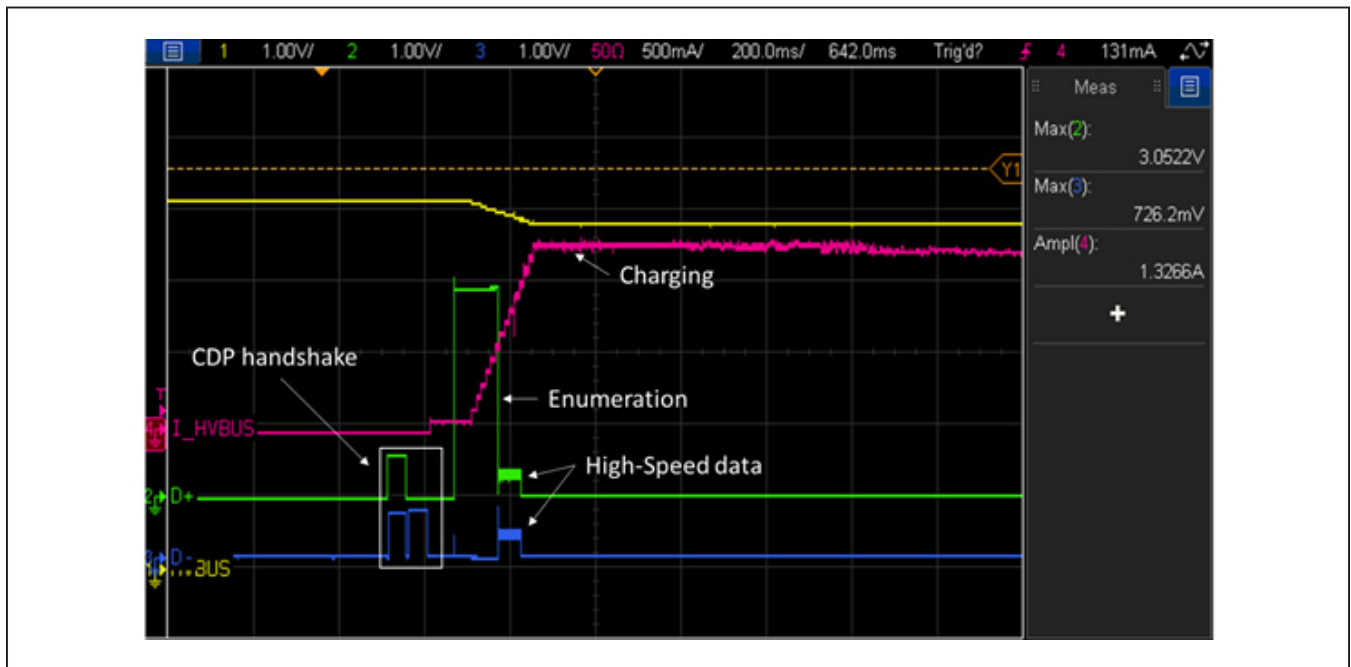

Figure 9. Auto-CDP Response

Note: Oscilloscope probes not shown in figures for simplicity.

E) Charge Emulation - Auto-DCP

The following procedure demonstrates how to evaluate MAX25410's auto-DCP mode.

Required Equipment

- MAX25410 EV kit
- 14V/1A DC power supply or car battery (V_{BAT})

- USB-C amperage meter (pluggable USBC-VAMETER or equivalent)
- USB-C device (smartphone recommended)
- 1.5A or greater Type-C or Type-A downstream port. If Type-A, an A-to-C adapter and extension cable (1m or shorter) are needed. See the example setups in [Figure 10](#) and [Figure 11](#).

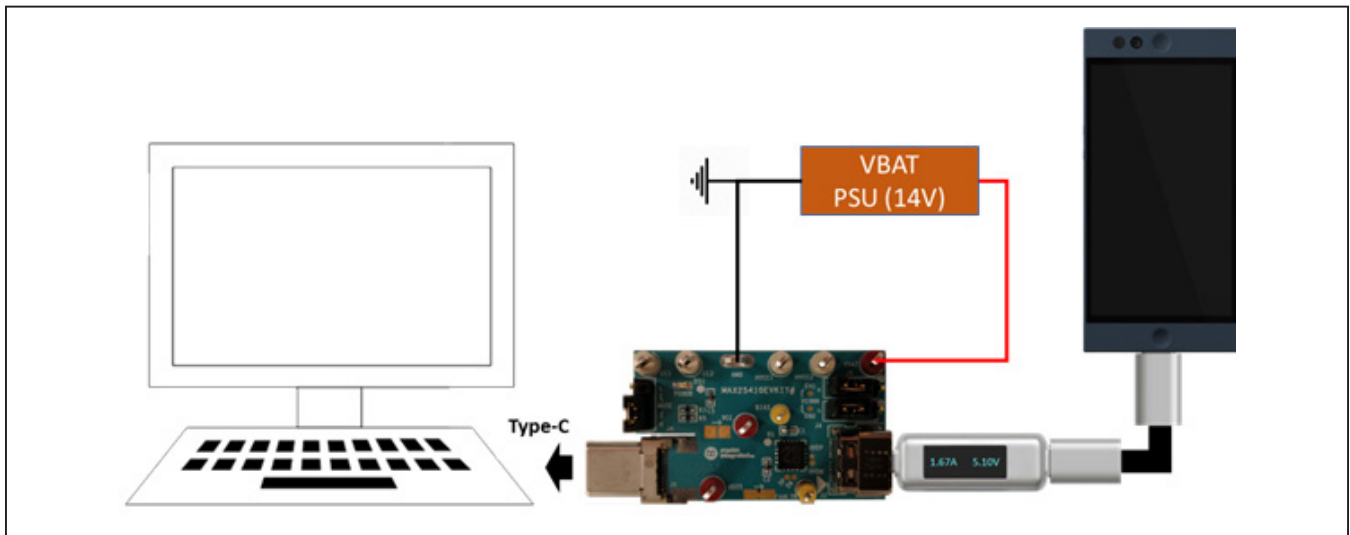

Figure 10. Auto-DCP Setup (Type-C Downstream Port)

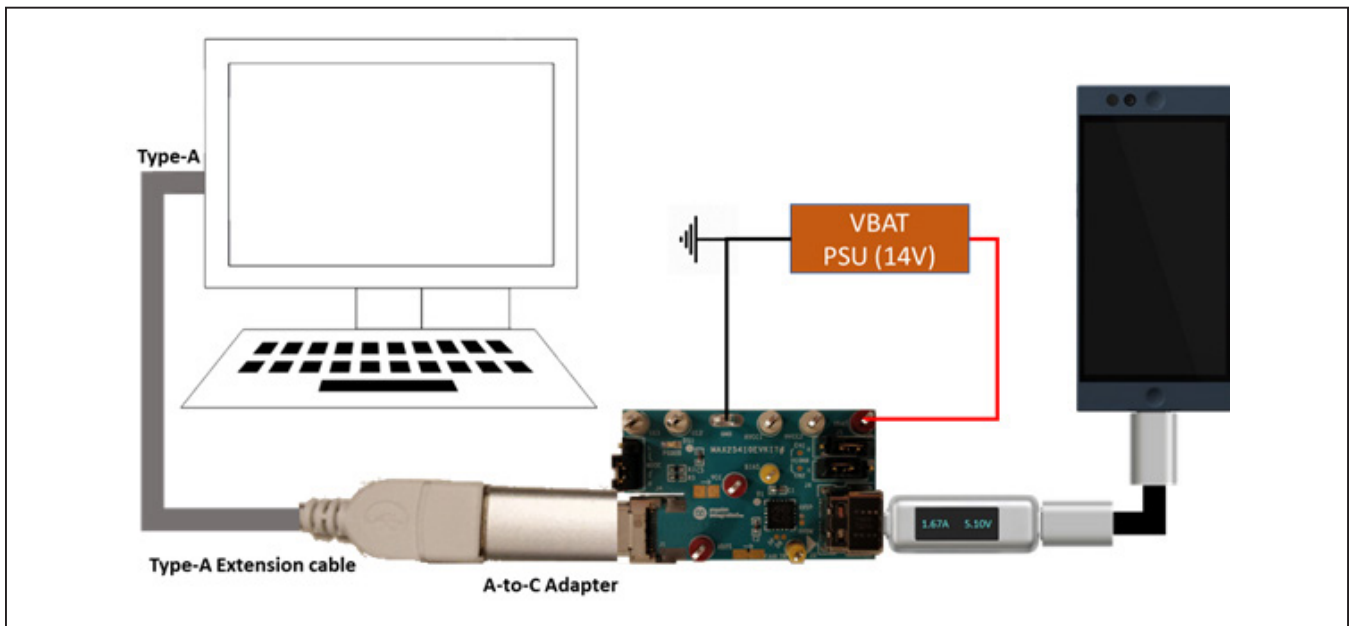

Figure 11. Auto-DCP Setup (Type-A Downstream Port)

Step-by-step

- 4) Verify that the PGOOD LED is illuminated. Verify that J4 is in the 'H' position (auto-DCP).
- 5) Connect the adapters, cables and phone per the picture. Check that the phone is now charging at up to 1.5A.
- 6) For an Android phone, note the DCP handshake on the HVDP and HVDM pins which indicates to the phone that it may pull up to 1.5A of load (Figure 12 below). For an Apple phone, the HVDP and HVDM will stay at 2.7V and will indicate to the phone it may pull up to 2.4A of current (Figure 13 below).

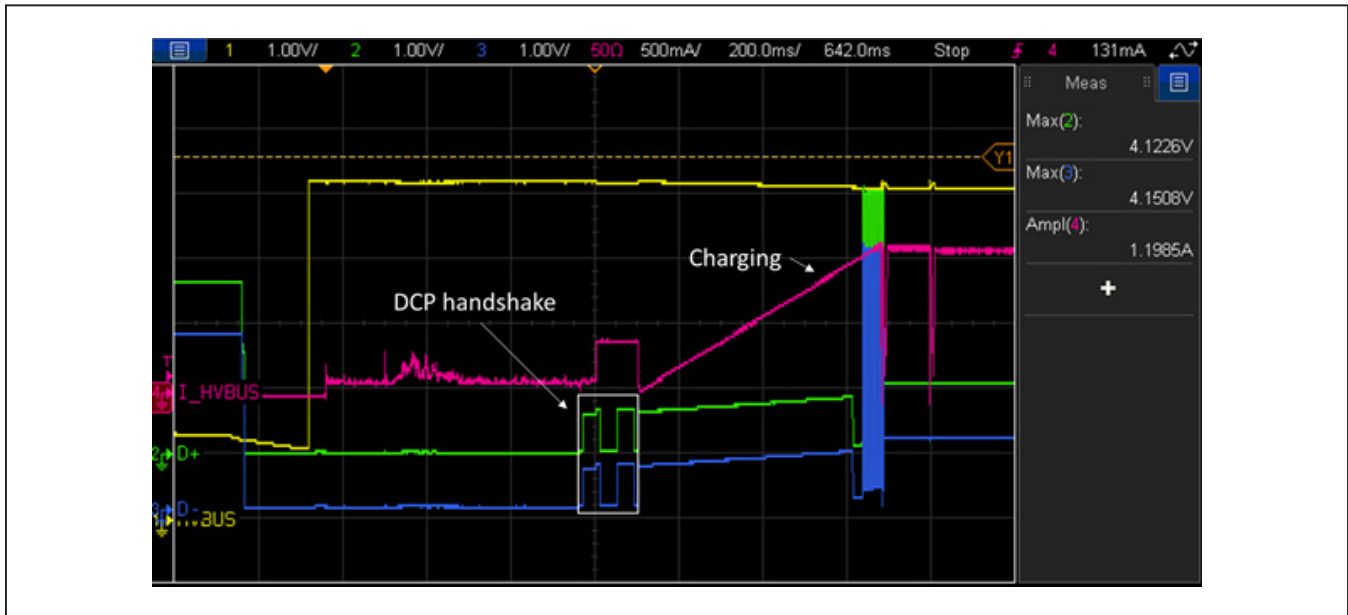

Figure 12. Auto-DCP Response with an Android phone



Figure 13. Auto-DCP Response with an Apple phone

USB Type-C & Legacy Apple/Samsung/USB DCP Charging

- The amperage meter should display USB current as the device charges.
 - Note that for most devices, maximum charging rate occurs between approximately 20% and 80% battery level.
- Certain USB type-C devices may prefer to follow the Type-C port current advertisement and ignore BC1.2 handshake. Source current advertisements can be any of the following:
 - 0.5A
 - 1.5A
 - 3.0A
- For non-native USB type-C devices (Apple 30-pin/lightning and USB mini/micro-b):
 - Apple devices may consume up to 2.4A maximum.
 - BC 1.2-compatible or Samsung devices will consume up to 1.5A or 2A, respectively.
- Note that some USB devices are compatible with multiple handshakes and may prefer one over the other, depending on many factors such as battery level and phone workload. The USB charging behavior can also depend on the version of software installed on the user's device, which can change over time as updates are released.

Ordering Information

PART	TYPE
MAX25410EVKIT#	EV Kit

#Denotes RoHS compliant.

MAX25410 EV Kit Bill of Materials

ITEM	REF_DES	DN/DNP	QTY	MFG PART #	MANUFACTURER	VALUE	DESCRIPTION
1	BIAS, FAULTB	—	2	5004	KEystone	N/A	TEST POINT; PIN DIA = 0.1IN; TOTAL LENGTH = 0.3IN; BOARD HOLE = 0.04IN; YELLOW; PHOSPHOR BRONZE WIRE SILVER PLATE FINISH;
2	C1, C2	—	2	C0402C105K8PAC; CC0402KRX5R6BB105	KEMET;YAGEO	1µF	CAPACITOR; SMT (0402); CERAMIC CHIP; 1µF; 10V; TOL = 10%; TG = -55°C TO +85°C; TC = X5R
3	C3	—	1	C0603C105K4RAC; GRM188R71C105KA12; C1608X7R1C105K080AC; EMK107B7105KA; GCM188R71C105KA64; CGA3E1X7R1C105K080AC	KEMET;MURATA; TDK;TAIYO YUDEN; MURATA;TDK	1µF	CAPACITOR; SMT (0603); CERAMIC CHIP; 1µF; 16V; TOL = 10%; MODEL = ; TG = -55°C TO +125°C; TC = X7R
4	C4	—	1	C1206C475K3RAC	KEMET	4.7µF	CAPACITOR; 1206; 4.7µF; 25V; 10%; X7R; -55°C TO +125°C
5	C5	—	1	CGA2B3X7R1H104K050BB; C1005X7R1H104K050BB; GRM155R71H104KE14; GCM155R71H104KE02; C1005X7R1H104K050BE; UMK105B7104KV-FR; CGA2B3X7R1H104K050BE	TDK;TDK;MURATA; MURATA;TDK; TAIYO YUDEN;TDK	0.1µF	CAPACITOR; SMT (0402); CERAMIC CHIP; 0.1µF; 50V; TOL = 10%; TG = -55°C TO +125°C; TC = X7R
6	C6	—	1	C2012X7S1A226M125AC	TDK	22µF	CAP; SMT (0805); 22µF; 20%; 10V; X7S; CERAMIC CHIP
7	C9	—	1	GRM32ER71E226KE15; CL32B226KAJNFN; CL32B226KAJNNW; TMK325B7226KM	MURATA; SAMSUNG ELECTRO-MECHANICS;TA	22µF	CAPACITOR; SMT (1210); CERAMIC CHIP; 22µF; 25V; TOL = 10%; TG = -55°C TO +125°C; TC = X7R
8	CC1, CC2, HVCC1, HVCC2	—	4	5007	KEystone	N/A	TEST POINT; PIN DIA = 0.125IN; TOTAL LENGTH = 0.35IN; BOARD HOLE = 0.063IN; WHITE; PHOSPHOR BRONZE WIRE SILVER PLATE FINISH;
9	D1	—	1	SDM20U40	DIODES INCORPORATED	SDM20U40	DIODE; SCH; SCHOTTKY BARRIER DIODE; SMT (SOD-523); PIV = 40V; IF = 0.25A
10	DM, DP, EN1, EN2, HVDM, HVDP	—	6	ANY	ANY	MICRO_TP	TEST POINT; MICRO_TP; PAD DIA: 0.8128 MM(32MILS) SOLDERMASK: 0.9144 MM(36MILS) THERMAL RELIEF/ANTI PAD: 1.574MM(62MILS); SMD
11	DS1	—	1	APT1608LZGCK	KINGBRIGHT	APT1608LZGCK	DIODE; LED; GREEN WATER CLEAR; GREEN; SMT (0603); VF = 2.65V; IF = 0.002A
12	J1	—	1	DX07P024MU1	JAE ELECTRONIC INDUSTRY	DX07P024MU1	CONNECTOR; FEMALE; SMT; USB 3.1; SUPERSPEED; RIGHT ANGLE; 24PINS
13	J2	—	1	2012670005	MOLEX	2012670005	CONNECTOR; FEMALE; SMT; USB TYPE C RECEPTACLE; RIGHT ANGLE; 24PINS
14	J4-J6	—	3	TSW-103-23-G-S	SAMTEC	TSW-103-23-G-S	CONNECTOR; THROUGH HOLE; SINGLE ROW; STRAIGHT; 3PINS; -55°C TO +125°C
15	L1	—	1	LQM21PZ4R7MGR	MURATA	4.7µH	INDUCTOR; SMT (0805); FERRITE; 4.7µH; 20%; 0.8A
16	R1	—	1	CRCW0402100KJN	VISHAY DALE	100K	RESISTOR; 0402; 100KΩ; 5%; 200PPM; 0.063W; THICK FILM
17	R2	—	1	ERJ-2RKF5102	PANASONIC	51K	RESISTOR; 0402; 51KΩ; 1%; 100PPM; 0.1W; THICK FILM
18	R3	—	1	CRCW040240K2FK	VISHAY DALE	40.2K	RESISTOR; 0402; 40.2KΩ; 1%; 100PPM; 0.063W; THICK FILM
19	R4, R5	—	2	ERJ-2RKF1002	PANASONIC	10K	RESISTOR; 0402; 10KΩ; 1%; 100PPM; 0.10W; THICK FILM
20	R6	—	1	CRCW0603000020	VISHAY DALE	0	RESISTOR; 0603; 0Ω; 0%; JUMPER; 0.1W; THICK FILM
21	SHUNT_ J4-SHUNT_J6	—	3	QPC02SXGN-RC	SULLINS ELECTRONICS CORP.	QPC02SXGN-RC	CONNECTOR; FEMALE; 0.100IN CC; OPEN TOP; JUMPER; STRAIGHT; 2PINS
22	U1	—	1	MAX25410AGTEV+	MAXIM	MAX25410AGTEV+	EVKIT PART - IC; PROT; AUTOMOTIVE USB POWER DELIVERY PORT PROTECTION/ PROTECTOR; PACKAGE OUTLINE DRAWING: 21-0139; PACKAGE CODE: T1644+4C; LAND PATTERN: 90-0070; TQFN16-EP
23	U2	—	1	MAX20075ATCA	MAXIM	MAX20075ATCA	IC; CONV; 36V 1A MINI BUCK CONVERTER WITH 5µA IQ; TDFN12-EP
24	VBAT, VBUS, VCC	—	3	5005	KEystone	N/A	TEST POINT; PIN DIA = 0.125IN; TOTAL LENGTH = 0.35IN; BOARD HOLE = 0.063IN; RED; PHOSPHOR BRONZE WIRE SILVER PLATE FINISH;
25	PCB	—	1	MAX25410	MAXIM	PCB	PCB:MAX25410
26	C7, C8	DNP	0	C0402C0G500-391JNE; GRM1555C1H391JA01; CGA2B2C0G1H391J050BA	VENKEL LTD.; MURATA;TDK	390PF	CAPACITOR; SMT (0402); CERAMIC CHIP; 390PF; 50V; TOL = 5%; MODEL = ; TG = -55°C TO +125°C; TC = C0G
TOTAL			42				

MAX25410 EV Kit Schematic Diagram

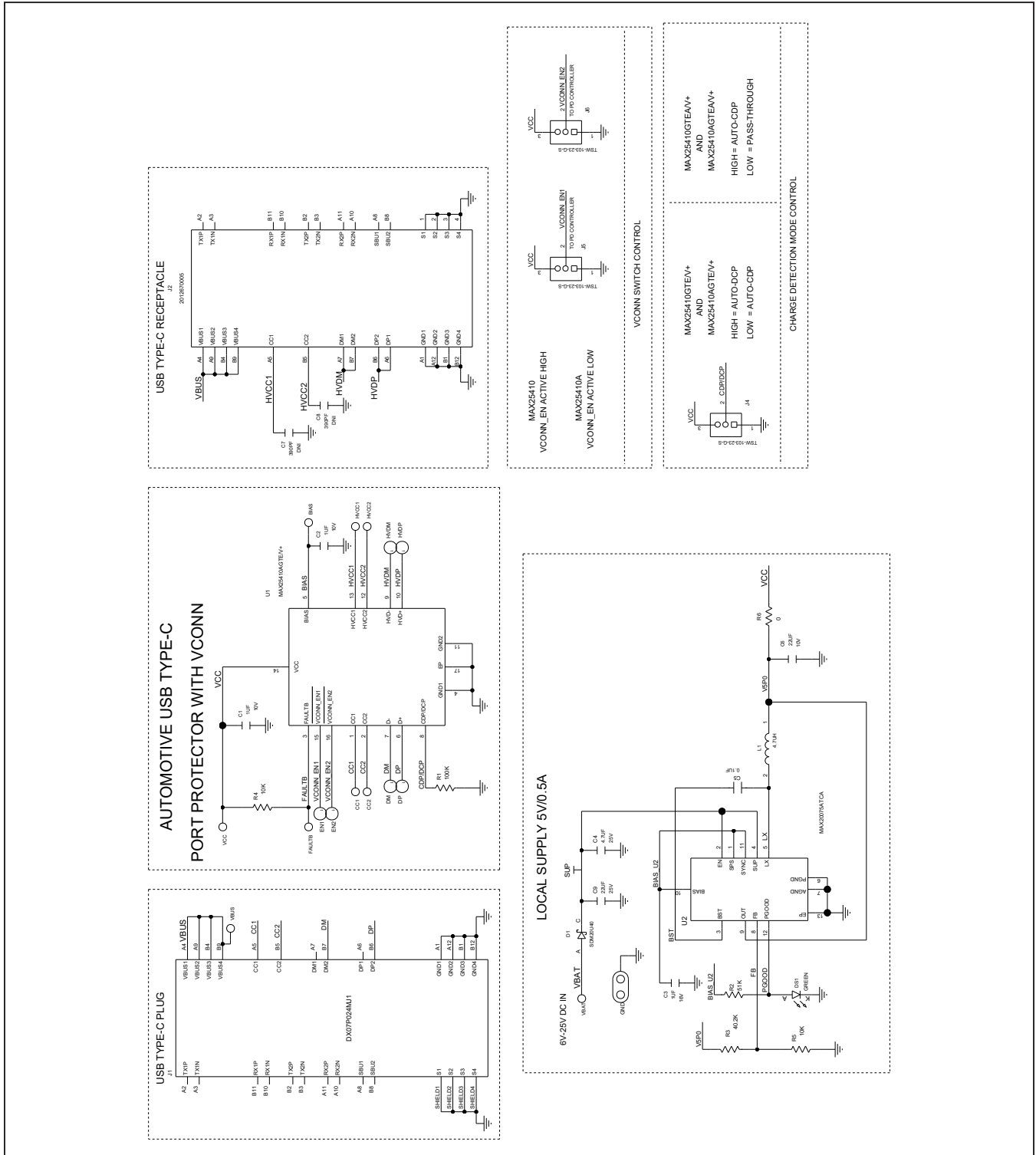

MAX25410 EV Kit PCB Layout Diagrams

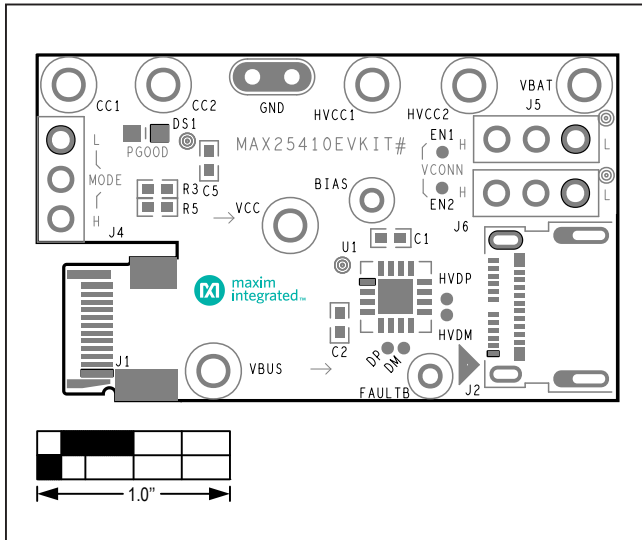

MAX25410 EV Kit PCB Layout – Top Silkscreen

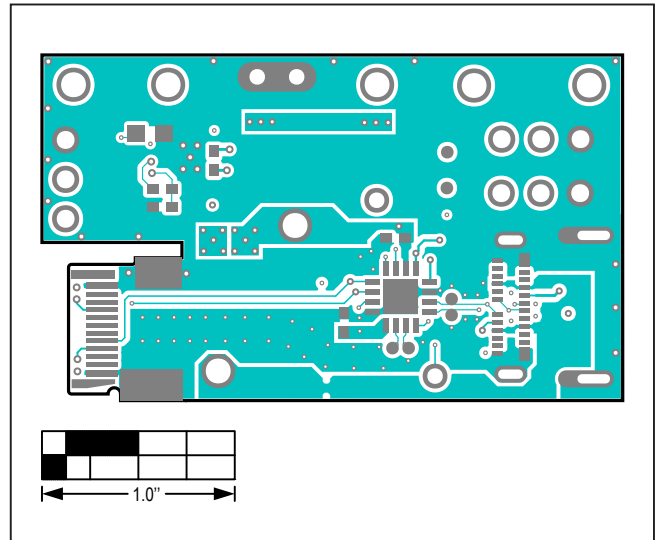

MAX25410 EV Kit PCB Layout – Top Layer

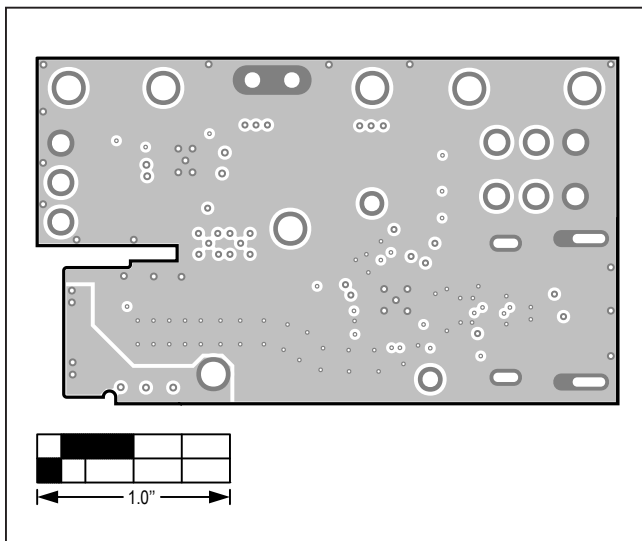

MAX25410 EV Kit PCB Layout – Layer 2

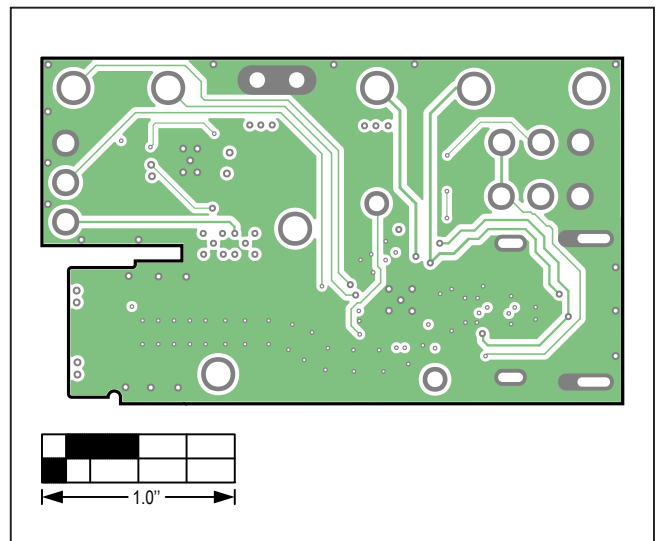

MAX25410 EV Kit PCB Layout – Layer 3

MAX25410 EV Kit PCB Layout Diagrams (continued)

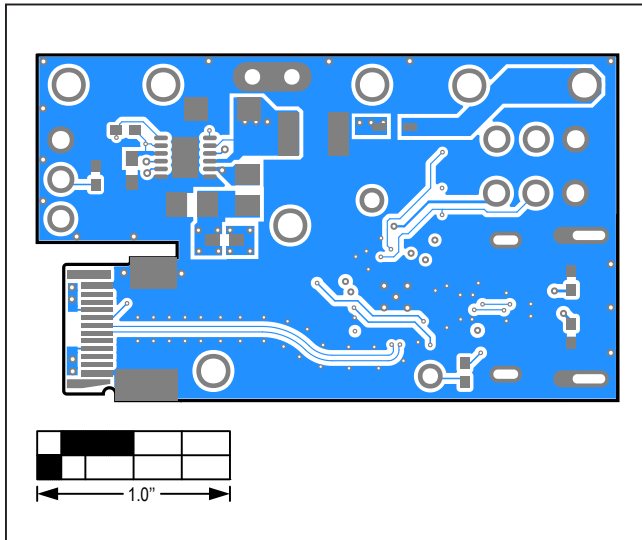

MAX25410 EV Kit PCB Layout – Bottom Layer

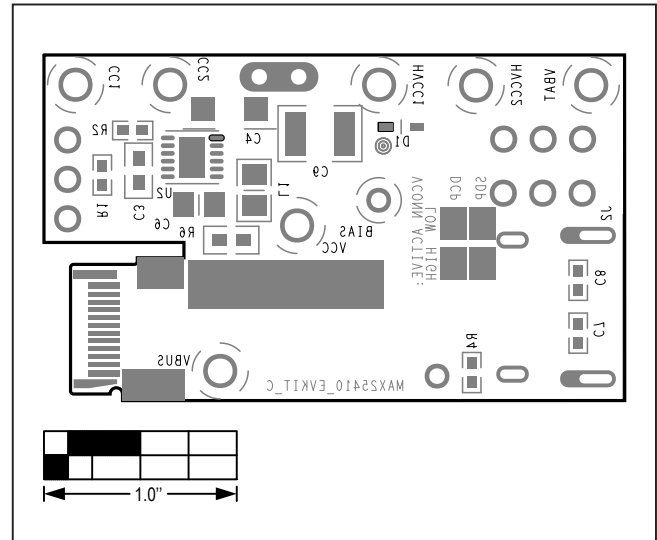

MAX25410 EV Kit PCB Layout – Bottom Silkscreen

Revision History

REVISION NUMBER	REVISION DATE	DESCRIPTION	PAGES CHANGED
0	1/20	Initial release	—
1	1/20	Removed MAX25410A from page header	1–17

For pricing, delivery, and ordering information, please visit Maxim Integrated's online storefront at <https://www.maximintegrated.com/en/storefront/storefront.html>.

Maxim Integrated cannot assume responsibility for use of any circuitry other than circuitry entirely embodied in a Maxim Integrated product. No circuit patent licenses are implied. Maxim Integrated reserves the right to change the circuitry and specifications without notice at any time.

X-ON Electronics

Largest Supplier of Electrical and Electronic Components

Click to view similar products for [Interface Development Tools](#) category:

Click to view products by [Maxim](#) manufacturer:

Other Similar products are found below :

[ADP5585CP-EVALZ](#) [CHA2066-99F](#) [AS8650-DB](#) [MLX80104 TESTINTERFACE](#) [416100120-3](#) [XR18910ILEVB](#) [XR21B1421IL28-0A-EVB](#) [TW-DONGLE-USB](#) [EVAL-ADM2491EEBZ](#) [MAXREFDES23DB#](#) [MAX13235EEVKIT](#) [DFR0257](#) [XR22404CG28EVB](#) [ZLR964122L](#) [ZLR88822L](#) [EVK-U23-01S](#) [EVK-W262U-00](#) [DC327A](#) [PIM511](#) [PIM536](#) [PIM517](#) [DEV-17512](#) [STR-FUSB3307MPX-PPS-GEVK](#) [MAXREFDES177#](#) [EVAL-ADM2567EEBZ](#) [ZSSC3240KIT](#) [MAX9121EVKIT](#) [PIM532](#) [ZSC31010KITV2P1](#) [UMFT4233HPEV](#) [LVDS-18B-EVK](#) [XR20M1172G28-0B-EB](#) [SI871XSOIC8-KIT](#) [1764](#) [1833](#) [1862](#) [EVB-USB82514](#) [ATA6628-EK](#) [ATA6631-EK](#) [EVAL-CN0313-SDPZ](#) [2264](#) [MCP23X17EV](#) [PS081-EVA-HR MODULE](#) [237](#) [SMA2RJ45EVK/NOPB](#) [FR12-0002](#) [MAFR-000455-001](#) [BOB-13263](#) [ORG4572-R01-UAR](#) [CPC5622-EVAL-600R](#)