

MAX25605

6 Switch Sequential LED Controller For Automotive Lighting Systems

General Description

The MAX25605 is a six-channel automotive sequential LED controller. The device implements a sequential turn function or any other sequential light animation without the use of a microcontroller or software. The MAX25605 integrates six cascoded low $R_{DS(ON)}$ n-channel MOSFETs suitable for LED lighting applications up to 750mA. Each switch supports up to three series LEDs per switch. The entire LED string voltage supported is up to 60V. The n-channel MOSFETs are divided into two groups of three, allowing a single device to sequence either one or two strings of LEDs. Integrated gate drivers and level shifters for the switches are supplied by an internal charge-pump regulator, supporting buck-boost and boost-to-battery applications, in addition to ground-referenced LED driver topologies.

Sequencing functionality and timing is programmed by connecting resistors to the A0, A1, A2, and CLK inputs. Programming options include: dimming up/down, short LED threshold, multi-device sequence position, dimming frequency, and fade duration. The optional logarithmic fade feature allows for gradually turning the LEDs on or off. The sequence can be disabled by pulling the enable input low. With EN pulled low, the switches are open and the LED driver current flows through the entire LED string. Each switch also integrates single-LED fault detection, asserting a fault flag in case of shorted LEDs, open LEDs, or open wires between the sequencer and the LED string. Additionally, up to 16 devices can be sequenced together through the use of a SYNC input.

The MAX25605 operates over the -40°C to $+125^{\circ}\text{C}$ automotive temperature range and is available in a 20-pin 4mmx4mm side-wettable TQFN and a 20-pin TSSOP package with exposed pad.

Applications

- Sequential Turn Signal Lights
- Hardware Based Lighting Animation

Benefits and Features

- Flexible Dimming Configuration Provides Optimal Performance without a Microcontroller or Software.
 - Simple Resistor Programming for Sequence Timing and Direction.
 - Hazard Light Applications
 - Sync Pin Allows Sequencing of up to 16 Devices
 - Optional Logarithmic LED Fade
- Flexible Configuration Allows the Use of the Same Device in Different Applications
 - One, Two, or Three Series LEDs per Switch
 - Floating Source MOSFETs
- EMI Reduction
 - Spread-Spectrum Oscillator
 - Slew Rate Control Minimizes LED Current Spikes
- Protection Features and Package Improve Reliability
 - Single-LED Short, Open, and Open-Trace Detection
 - Thermal Shutdown and Fault Flag
- Automotive Ready
 - AEC-Q100 Qualified
 - -40°C to $+125^{\circ}\text{C}$ Operating Temperature Range

Ordering Information appears at end of datasheet.

Simplified Block Diagram

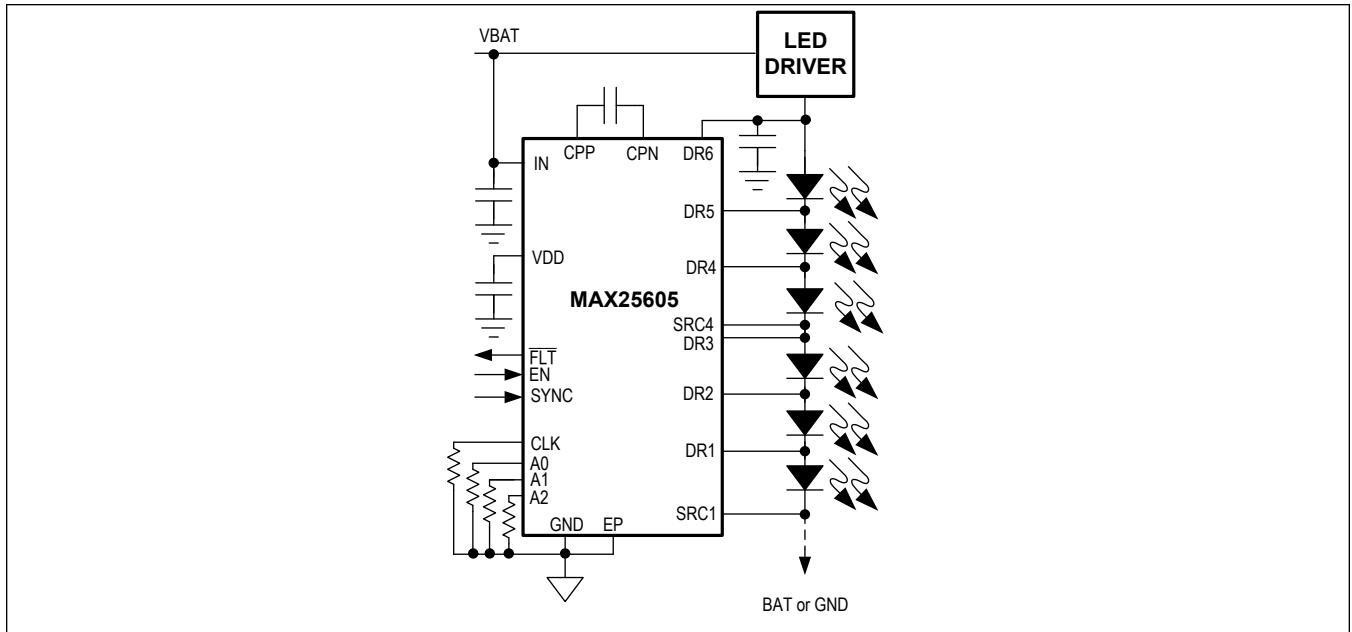

TABLE OF CONTENTS

General Description	1
Applications	1
Benefits and Features	1
Simplified Block Diagram	2
Absolute Maximum Ratings	7
Package Information	7
20 TQFN-EP* (SW)	7
20 TSSOP-EP*	7
Electrical Characteristics	8
Pin Configurations	10
TQFN	10
TSSOP	10
Pin Description	10
Functional Diagrams	12
MAX25605 Block Diagram	12
Detailed Description	13
Internal Switches	13
Charge Pump	13
Enable Function (EN)	13
t_{SEQ} Programming (CLK)	14
Timing Diagram	15
Synchronizing Multiple MAX25605 Devices (SYNC)	16
Sequence with Fade	16
Programming Options	16
Pin Resistor Programming	16
MAX25605 Pin Resistor Decode Table	17
Fault Indicator (FLT)	18
LED Open Fault Detection and Protection	18
LED Short Detection	18
Open Trace Detection	19
Thermal Protection	19
Applications Information	21
RCLK Selection	21
Fade	21
Hazard Light	21
Example Sequential Turn Signal	21
DR_ Leakage Current	23
Thermal Considerations	23

TABLE OF CONTENTS (CONTINUED)

Layout Considerations	23
Typical Application Circuits	24
Typical Applications Circuit	24
12 Segment Design from a Single LED Driver	25
12 Segment Applications Circuit with Separate LED Drivers	26
Five Segment Applications Circuit	27
Four Segment Applications Circuit	27
Three Segment Applications Circuit	28
Ordering Information	28
Revision History	29

LIST OF FIGURES

Figure 1. Timing Diagram	15
Figure 2. Fault Mask Timing Diagram	19
Figure 3. Example Application Circuit	22
Lighting Sequence Corresponding to the Figure 4. Circuit	23

LIST OF TABLES

Table 1. A0/A1/A2 Recommended Values	16
Table 2. Short-LED Voltage Threshold	17
Table 3. Dimming Direction	17
Table 4. Sequence Assignment	17
Table 5. Number of Switches	17
Table 6. Fade Setting	18

Absolute Maximum Ratings

IN to GND	-0.3V to +65V	DR1 to SRC1	-0.3V to +16V
V _{DD} to GND	-0.3V to +2.5V	EN, FLT, SYNC, CLK to GND	-0.3V to +6V
CPN to GND	-0.3V to +65V	A0, A1, A2 to GND	-0.3V to V _{DD} + 0.3V
CPP to GND	-0.3V to +70V	Continuous Power Dissipation (20-Pin TQFN SW) (T _A = +70°C, derate 25.6mW/°C above +70°C)	2050mW
CPP to CPN	-0.3V to +6V	Continuous Power Dissipation (20-Pin TSSOP) (T _A = +70°C, derate 26mW/°C above +70°C)	2122mW
CPP to DR6	-0.3V to +70V	Operating Temperature Range	-40°C to +125°C
DR6 to GND	-0.3V to +65V	Junction Temperature	+150°C
DRx to DR(x-1) ((note 1))	-0.3V to +16V	Storage Temperature Range	-40°C to +150°C
SRCx to GND	-0.3V to +65V	Soldering Temperature (reflow)	+260°C
DR6 to SRC4	-0.3V to +48V		
DR4 to SRC4	-0.3V to +16V		
DR3 to SRC1	-0.3V to +48V		

Note 1: Does not apply to DR4 to DR3.

Stresses beyond those listed under "Absolute Maximum Ratings" may cause permanent damage to the device. These are stress ratings only, and functional operation of the device at these or any other conditions beyond those indicated in the operational sections of the specifications is not implied. Exposure to absolute maximum rating conditions for extended periods may affect device reliability.

Package Information

20 TQFN-EP* (SW)

Package Code	T2044Y+3C
Outline Number	21-100068
Land Pattern Number	90-0037
Thermal Resistance, Single-Layer Board:	
Junction to Ambient (θ _{JA})	59°C/W
Junction to Case (θ _{JC})	6°C/W
Thermal Resistance, Four-Layer Board:	
Junction to Ambient (θ _{JA})	39°C/W
Junction to Case (θ _{JC})	6°C/W

20 TSSOP-EP*

Package Code	U20E+3C
Outline Number	21-100132
Land Pattern Number	90-100049
Thermal Resistance, Single-Layer Board:	
Junction to Ambient (θ _{JA})	46°C/W
Junction to Case (θ _{JC})	2°C/W
Thermal Resistance, Four-Layer Board:	
Junction to Ambient (θ _{JA})	37°C/W
Junction to Case (θ _{JC})	2°C/W

For the latest package outline information and land patterns (footprints), go to www.maximintegrated.com/packages. Note that a "+", "#", or "-" in the package code indicates RoHS status only. Package drawings may show a different suffix character, but the drawing pertains to the package regardless of RoHS status.

Package thermal resistances were obtained using the method described in JEDEC specification JESD51-7, using a four-layer board. For detailed information on package thermal considerations, refer to www.maximintegrated.com/thermal-tutorial.

Electrical Characteristics

(Input Voltage = $V_{IN} = 5V$, $T_A = T_J = -40^{\circ}C$ to $+125^{\circ}C$, unless otherwise noted. Typical values are at $T_A = +25^{\circ}C$. Limits over the operating temperature range and relevant supply voltage range are guaranteed by design and characterization. (Note 2))

PARAMETER	SYMBOL	CONDITIONS	MIN	TYP	MAX	UNITS
Supply Voltages						
Supply Voltage	V_{IN}	Operating Voltage Range	4.0		60	V
Input Current	I_{IN}			2	5	mA
Input POR Threshold	V_{IN-POR}	V_{IN} Rising	3.6		3.9	V
Charge-Pump Operating Voltage	V_{CPP}				65	V
V_{DD} Regulator						
V _{DD} Output	V_{DD}	2.2 μ F capacitor placed between V _{DD} and GND pins. $I_{VDD} = 10mA$	1.71	1.8	1.89	V
V _{DD} UVLO Rising Threshold	UVLO_R_TH		1.61		1.69	V
V _{DD} UVLO Falling Threshold	UVLO_F_TH		1.54		1.63	V
LED Sequence Timing						
Sequence Period	t_{SEQ}	$R_{CLK} = 9.09k\Omega$		9.8		ms
		$R_{CLK} = 15.0k\Omega$		16		
	T_{SEQ}	$R_{CLK} = 47.5k\Omega$	47.5	50	52.5	
LED Switches						
Single Switch On-Resistance	R_{DSON}			0.2		Ω
On-Resistance with Series Switches 3-1 On				0.6	1.2	Ω
On-Resistance with Series Switches 6-4 On				0.6	1.2	Ω
Open LED Threshold	V_{OTH}		12.5	13.75	15	V
Open Trace Threshold	I_{LED_MIN}	Minimum Current Required to Detect Open Trace		45	100	mA
Short LED Threshold	V_{STH}	$R_{A0} = 95.3\Omega$ or 1050Ω , Rising V_{DS}	1.26	1.40	1.54	V
		$R_{A0} = 200\Omega$ or 1210Ω , Rising V_{DS}	3.24	3.6	3.96	
		$R_{A0} = 309\Omega$ or 1400Ω , Rising V_{DS}	3.6	4.00	4.4	
		$R_{A0} = 422\Omega$ or 1620Ω , Rising V_{DS}	4.95	5.5	6.05	
		$R_{A0} = 536\Omega$ or 1870Ω , Rising V_{DS}	5.4	6.0	6.6	
		$R_{A0} = 649\Omega$ or 2150Ω , Rising V_{DS}	5.94	6.6	7.26	
		$R_{A0} = 768\Omega$ or 2490Ω , Rising V_{DS}	6.48	7.2	7.92	
		$R_{A0} = 909\Omega$ or 2870Ω , Rising V_{DS}	6.93	7.70	8.47	
FLT Flag						
\overline{FLT} Output Low Voltage		$I_{SINK} = 2 mA$		0.06	0.4	V
\overline{FLT} Output High Leakage Current		$\overline{FLT} = 5V$			1	μA

Electrical Characteristics (continued)

(Input Voltage = $V_{IN} = 5V$, $T_A = T_J = -40^{\circ}C$ to $+125^{\circ}C$, unless otherwise noted. Typical values are at $T_A = +25^{\circ}C$. Limits over the operating temperature range and relevant supply voltage range are guaranteed by design and characterization. (Note 2))

PARAMETER	SYMBOL	CONDITIONS	MIN	TYP	MAX	UNITS
DIGITAL INPUTS (EN, SYNC)						
Input High Voltage	V_{IH}		1.4			V
Input Low Voltage	V_{IL}				0.4	V
Input Leakage Current	I_{LEAK}	Input driven to 0V or 5V			± 1	μA
DIGITAL OUTPUTS (EN, SYNC)						
Output Low Voltage	V_{OL}	$I_{SINK} = 2mA$			0.4	V
THERMAL SHUTDOWN						
Thermal-Warning Threshold	TH_WARN	Rising temperature		140		$^{\circ}C$
Thermal-Warning Hysteresis	HYS_WARN			15		$^{\circ}C$
Thermal-Shutdown Threshold	TH_SHDN	Rising temperature		165		$^{\circ}C$
Thermal-Shutdown Hysteresis	HYS_SHDN			15		$^{\circ}C$
CHARGE PUMP						
Charge-Pump Frequency	f_{CPP}			16.384		MHz
Charge-Pump Output Voltage	V_O	$V_{CPP} - V_{CPN}$, $I_{CPP} = 190\mu A$	3.8		5.8	V
Charge-Pump Power-Good Threshold	V_{CPP_OK}	Rising threshold		4.0		V

Note 2: Limits are 100% production tested at $T_A = +25^{\circ}C$. Limits over the operating temperature range and relevant supply voltage are guaranteed by design and characterization.

Note 3: Bias current into the larger of V_{IN} , V_{DR6} , or V_{DR3}

Pin Configurations

TQFN

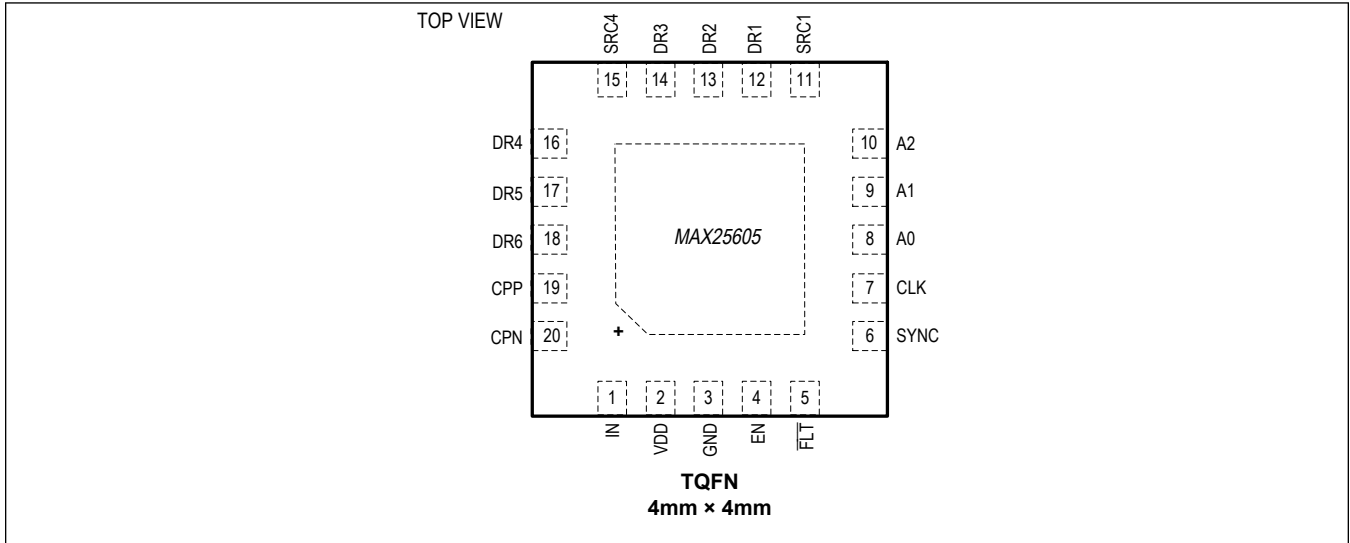

TSSOP

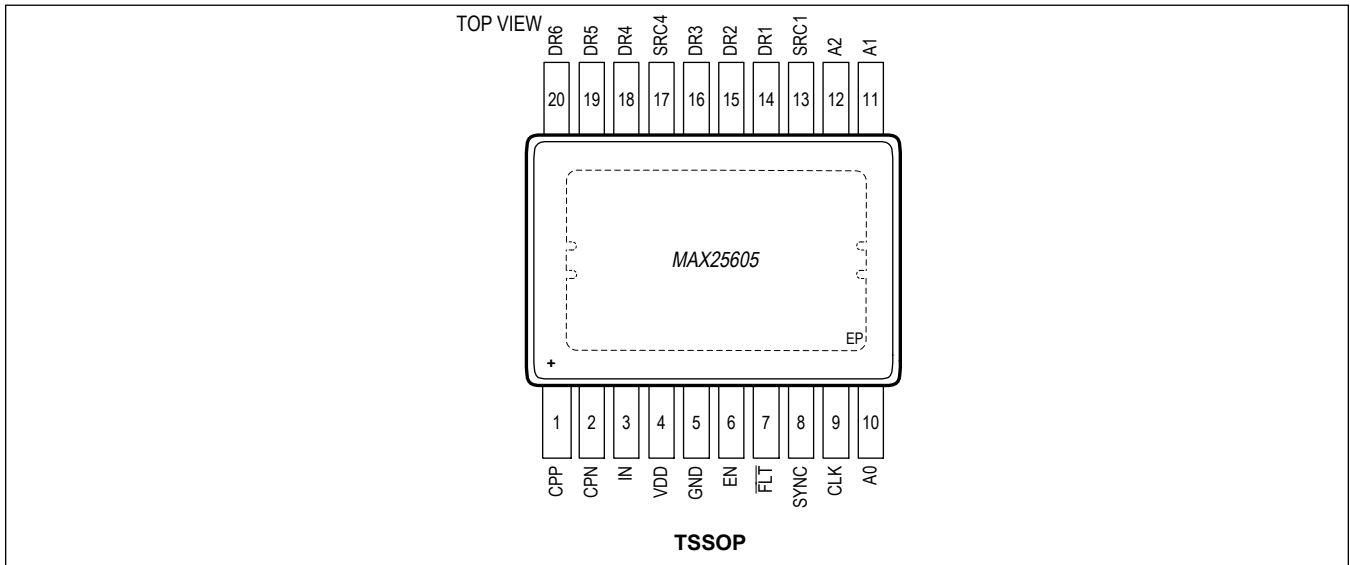

Pin Description

PIN		NAME	FUNCTION
TQFN	TSSOP		
1	3	IN	Input Supply. Connect to external power supply to provide power to the device. Connect a minimum 0.1µF ceramic capacitor between IN and GND.

Pin Description (continued)

PIN		NAME	FUNCTION
TQFN	TSSOP		
2	4	V _{DD}	LDO Output. Nominal voltage is 1.8V. Connect a minimum 2.2µF ceramic capacitor between V _{DD} and GND.
3	5	GND	Ground Connection
4	6	EN	Pull EN pin low to turn all the switches off. EN pin is a bidirectional pin. EN is released internally only when charge pump voltage reaches regulation. EN going high activates sequence function.
5	7	$\overline{\text{FLT}}$	Open-Drain Fault Indicator. Goes low when a fault condition is present.
6	8	SYNC	Open-Drain Synchronization I/O. Connect the SYNC I/O of each MAX25605 together to implement sequences of more than six LED segments.
7	9	CLK	Sequence Period Programming Input. Connect a resistor from CLK to GND to set the sequence period.
8	10	A0	A0 Programming Input. Connect the appropriate resistor value from A0 to GND in accordance with Table 1 .
9	11	A1	A1 Programming Input. Connect the appropriate resistor value from A1 to GND in accordance with Table 1 .
10	12	A2	A2 Programming Input. Connect the appropriate resistor value from A2 to GND in accordance with Table 1 .
11	13	SRC1	Source of Internal Switch 1
12	14	DR1	Drain of Internal Switch 1
13	15	DR2	Drain of Internal Switch 2
14	16	DR3	Drain of Internal Switch 3
15	17	SRC4	Source of Internal Switch 4
16	18	DR4	Drain of Internal Switch 4
17	19	DR5	Drain of Internal Switch 5
18	20	DR6	Drain of Internal Switch 6
19	1	CPP	Charge Pump Capacitor Positive Connection. Connect a 0.1µF ceramic capacitor from CPP to CPN.
20	2	CPN	Charge Pump Capacitor Negative Connection. Connect a 0.1µF ceramic capacitor from CPP to CPN.
-	—	EP	Exposed Pad Connection. Connect this pad to a contiguous ground plane.

Functional Diagrams

MAX25605 Block Diagram

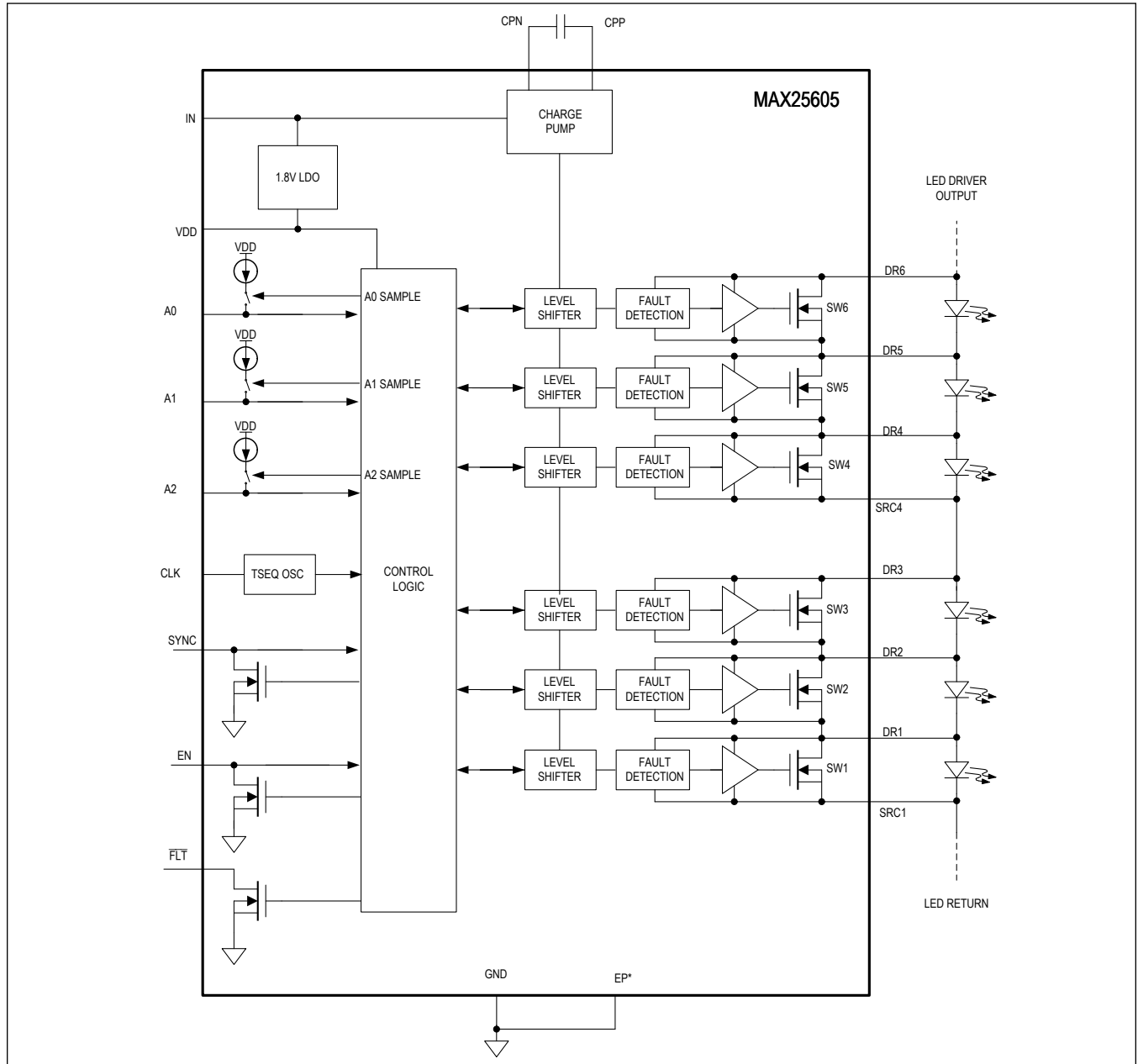

Detailed Description

The MAX25605 consists of 6 switches in series and is designed for use in sequential-turn applications. The device switches the sequential-turn LEDs on or off by opening or shorting the switches. The device can have 1, 2, or 3 LEDs in series across each switch. The typical on-resistance of each of the switches in the MAX25605 is 0.2Ω . The low on-resistance of the switches minimizes conduction loss and power dissipation. The device is suitable for sequential-turn applications for currents as high as 750mA. In addition to single-string applications, the device can also be configured for two-string applications. The operating voltage across each switch should not exceed the minimum open threshold voltage. The maximum withstand voltage for the entire LED string is 60V. The MAX25605 also includes an internal charge pump that provides power for the gate drive for each of the LED bypass switches.

The IC includes a bidirectional EN pin that is released internally when the charge pump has reached the correct regulation voltage. Sequencing of the switches begins when EN goes high. The LEDs are turned either on or off with the timing and direction as set by the A0, A1, and A2 external programming resistors. The device includes a FLT pin that indicates LED-open or LED-short faults or activation of thermal shutdown. In addition to sequential turn, the device can also be used in hazard-light applications where all the LEDs are turned on simultaneously by turning off all the switches in the MAX25605 at the same time. This is achieved by pulling EN pin low. The device is available in a 20-pin 4mmx4mm side-wettable TQFN and a 20-pin TSSOP package with exposed pad.

Internal Switches

Each switch connected between DR_n and DR_{n-1} has a typical on-resistance of 0.2Ω . This measurement includes the on-resistance of the internal switch and the resistance of the bond wires to the DR_n and DR_{n-1} pads. Each bypass switch, when driven to an off state, allows the string current to flow through the corresponding parallel-connected LED, turning the LEDs on. Driving the bypass switch to an on state shunts the current through the bypass switch and turns the LEDs off. Each bypass switch can have one, two or three LEDs in series across it.

All six switches are connected in a cascode configuration to allow for animation in applications where the LED string cathode does not connect to ground. The switches are divided into two groups of three to give the option of controlling two parallel LED strings with a single MAX25605 device. Alternatively, a single string can be controlled by connecting SRC4 and DR3 externally.

The slew rate of the switches is controlled to minimize the current undershoot or overshoot during segment transitions. The switch slew rate is approximately 333 mV/ μ s.

Charge Pump

The MAX25605 integrates a charge pump that provides the voltage rails for each switch gate driver and level shifter. The charge pump requires a single 0.1μ F capacitor connected between CPP and CPN for operation. The charge pump includes spread spectrum, which dithers the switching frequency by $\pm 6\%$ around the fundamental of 16.384MHz. The input power for the charge pump is taken from the higher voltage of IN, DR6, or DR3. Therefore, IN and DR6 should have an external decoupling capacitor of at least 0.01μ F as close as possible to the device, assuming DR6 is always a greater voltage than DR3. If the DR6 and DR3 segments are controlling two different LED strings, then DR3 should also have a close decoupling capacitor.

Enable Function (EN)

EN acts as both an enable input and an open-drain output. During initial power-up, the MAX25605 will pull down on the EN pin until all internal circuits are powered and ready to control the switches. Therefore, EN can be tied to the PWM or enable input of the LED driver to ensure that the current is not sourced to the LEDs prior to the MAX25605 waking up. When the device releases EN, this signals that the system is ready to control the current in the external LEDs. Multiple MAX25605 devices can have their EN pins tied together in an open-drain bus configuration. While the EN pin is low, all switches will remain in the open position. The host system can force the EN pin low indefinitely if desired. This will keep all switches off to allow for emergency-mode full-brightness lighting in the external LEDs. Because the fault-detection algorithm requires the switch transition to recognize fault conditions, the fault-detection block is disabled while EN is low. When the EN pin is released high, the MAX25605 is enabled. The switches will then be opened or closed, and the control

sequence will begin as determined by the external pin resistor programming.

t_{SEQ} Programming (CLK)

The CLK input configures the single step sequence period, t_{SEQ}, of the device. The total sequence time for the entire animation is t_{SEQ} x n, where t_{SEQ} value is programmed by the RCLK resistor and n is the number of sequence steps. CLK uses a V-to-I converter, forcing a fixed voltage on RCLK and mirroring the corresponding current into the t_{SEQ} oscillator. Unlike the A0/A1/A2 programming inputs which are only sampled during power up, the CLK input is active continuously during operation. Use the following equation to choose RCLK:

$$RCLK = (t_{SEQ} - 0.17)/1.045$$

where RCLK is in k Ω and t_{SEQ} is in ms.

It is recommended to choose a t_{SEQ} value between 2ms and 100ms.

Timing Diagram

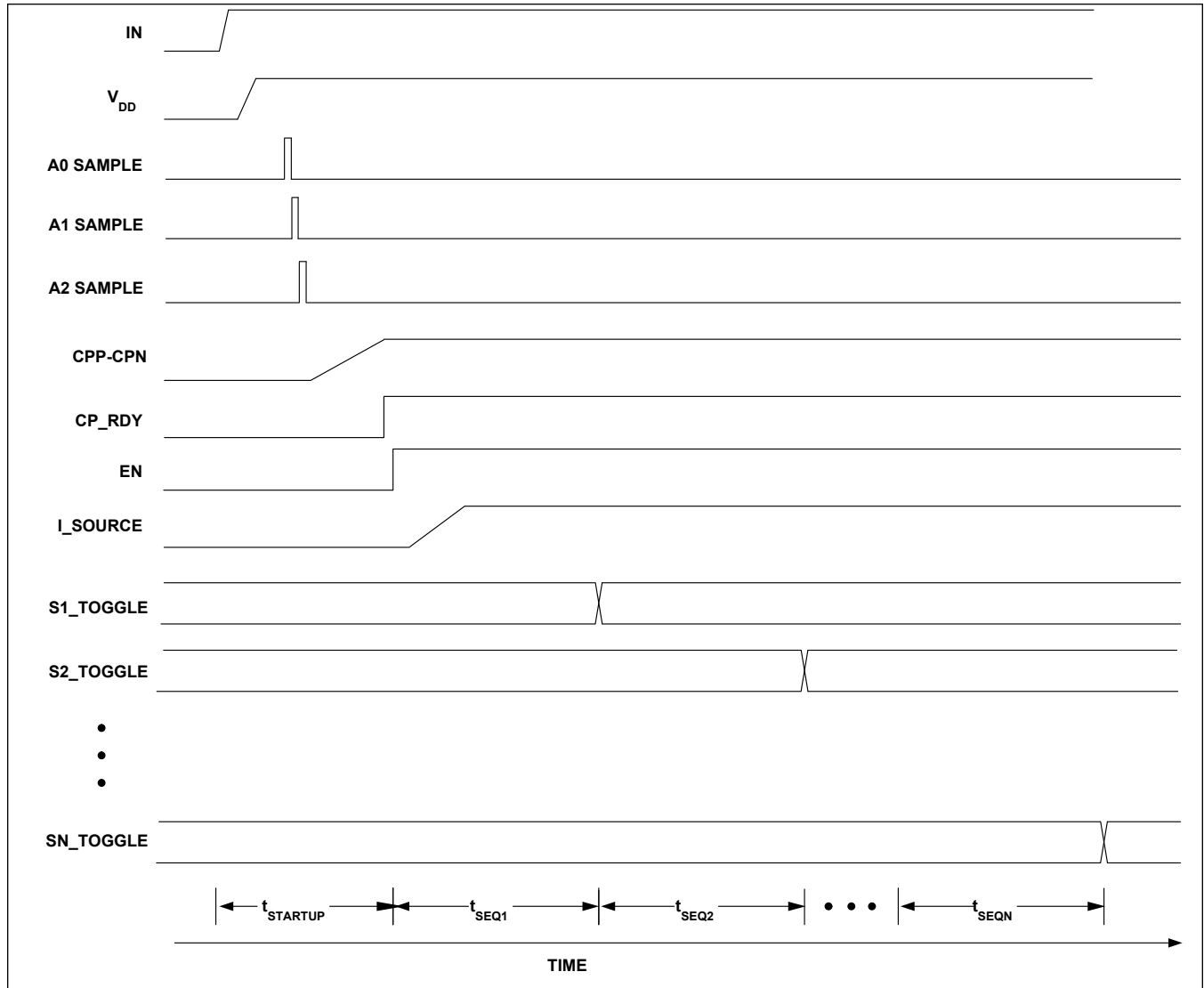

Figure 1. Timing Diagram

The startup sequence begins with IN rising above its UVLO. The V_{DD} will turn on and power up to 1.8V. Once the V_{DD} has come up, a pulsed current is forced through the A0, A1, and A2 resistors and the corresponding voltage is sampled to set the configuration of the device. Finally, the charge pump will power up and provide bias to the level-shift and gate-drive circuitry. Once the internal bias blocks and charge pump have finished turning on, the device startup is completed and the EN signal is released. At this point, the LED current source can be enabled. The MAX25605 will begin sequencing the switches according to the sampled A0, A1, and A2 resistor settings. All switches start either closed or open depending on whether DIM UP or DIM DOWN is configured. At the end of the first t_{SEQ} period, the first switch in the sequence will change its state. The sequence continues until the nth t_{SEQ} period has completed and the nth switch changes its state. After the last t_{SEQ} period, the switches will remain in their ending state until the IN or EN input is toggled.

Synchronizing Multiple MAX25605 Devices (SYNC)

The MAX25605 can synchronize multiple devices together to create a sequence of more than 6 LED segments. The sequence position is programmed by the A1 resistor programming input, allowing for up to 16 sequence positions. The SYNC of each MAX25605 should be connected together and the entire SYNC net should be pulled up to V_{DD} through a 10k Ω pullup resistor. The SYNC function works by counting low-to-high transitions. At the beginning of a multi-device sequence, the device that is programmed as Device 0 will start. While Device 0 is performing its sequence, an open-drain MOSFET inside Device 0 will pull SYNC low. Once the sequence of that device has been completed, it will release the SYNC net, causing a low-to-high transition. At that time, the device that has been configured as Device 1 will begin its sequence. The sequence will continue with each device waiting for the correct number of low-to-high transitions on SYNC before they start their own sequence. Once the entire multi-device sequence has completed, the devices will remain in their ending state until either the EN input or IN input is toggled.

Sequence with Fade

The MAX25605 has the option of adding a logarithmic fade to each step of the LED sequence. If fade is enabled, the LED will take between 1 and 3 t_{SEQ} periods (programmable by A2) to step from the initial to the final brightness, where t_{SEQ} is the sequence timing set by R_{CLK} . If dim up is enabled, the LEDs will gradually fade from no light to full brightness. If dim down is enabled, the LEDs will gradually fade from full brightness to no light.

The LED brightness is faded up or down by gradually increasing or decreasing the PWM duty cycle of the corresponding switch. When dimming up, each PWM pulse is 1.0625 times longer than the preceding pulse width. When dimming down, each PWM pulse is multiplied by 0.9375 (reduced) compared to the preceding pulse width.

The PWM dimming frequency that implements the fade effect depends on the following equation:

$$f_{PWM} = \frac{75}{(NFADE \times T_{SEQ})}$$

where f_{PWM} is the PWM dimming frequency in kHz, 75 is an internal device constant, NFADE is the FADE number setting programmed by the A2 resistor (either 1, 2, or 3), and T_{SEQ} is the sequence time, programmed by R_{CLK} , in milliseconds.

Programming Options

Pin Resistor Programming

The IC provides 16 levels of detection between 0 and 1.2V on the A0, A1 and A2 pins, which are used to configure the MAX25605 switching behavior. The pins source 400 μ A, allowing the use of an external resistor between A0/A1/A2 and GND to set the voltage level. See [Table 1](#) for recommended resistor values.

Table 1. A0/A1/A2 Recommended Values

A0/A1/A2[3:0] DECODE VALUE	A0/A1/A2 RESISTOR VALUE (Ω , 1%)
0000	95.3
0001	200
0010	309
0011	422
0100	536
0101	649
0110	768
0111	909
1000	1050
1001	1210

Table 1. A0/A1/A2 Recommended Values (continued)

1010	1400
1011	1620
1100	1870
1101	2150
1110	2490
1111	2870

MAX25605 Pin Resistor Decode Table

The decoded A0[3:0] value is used to program the short-LED voltage threshold, as well as the dimming direction.

Table 2. Short-LED Voltage Threshold

A0[2:0]	VSTH
000	1.4V
001	3.6V
010	4.0V
011	5.5V
100	6.0V
101	6.6V
110	7.2V
111	7.7V

Table 3. Dimming Direction

A0[3]	DIMMING BEHAVIOR
0	Dim Down: All switches begin in the open state, allowing all LEDs to turn on. Switches close one at a time, starting from SW6 and ending with all switches closed and all LEDs off.
1	Dim Up: All switches begin in the closed state with all LEDs shunted off. The switches open one a time, starting from SW1 and ending with all switches open and all LEDs on.

The decoded A1[3:0] value is used to program the order of multiple MAX25605 devices. This allows multiple sequential controllers to be chained together. A device with a Sequence setting of zero will proceed with its sequence as soon as its EN pin is asserted. A device with Sequence = N will wait for N pulses on its SYNC input before starting its sequence. The device outputs a pulse on SYNC as soon as its sequence is complete.

Table 4. Sequence Assignment

A1[3:0]	SEQUENCE ASSIGNMENT
0000	0 (start on power-up)
0001	Wait for 1 SYNC pulse
0010	Wait for 2 SYNC pulses
...	...
1111	Wait for 15 SYNC pulses

The decoded A2[1:0] value is used to select the number of switches being used in the application. Unused switches will remain closed while EN is high.

Table 5. Number of Switches

A2[1:0]	NUMBER OF SWITCHES
00	NSW = 3 Switches 1/2/3 are active, switches 4/5/6 are not used

Table 5. Number of Switches (continued)

01	NSW = 4 Switches 1/2/4/5 are active, switches 3/6 are not used
10	NSW = 5 Switches 1/2/3/4/5 are active, switch 6 is not used
11	NSW = 6 All 6 switches are active

The decoded A2[3:2] value is used to enable fade behavior to the LED dimming, and set the duration of each fade transition.

Table 6. Fade Setting

A2[3:2]	FADE BEHAVIOR
00	No fade
01	Fade enabled, 1 t _{SEQ} period
10	Fade enabled, 2 t _{SEQ} periods
11	Fade enabled, 3 t _{SEQ} periods

Fault Indicator ($\overline{\text{FLT}}$)

The $\overline{\text{FLT}}$ output asserts whenever one or more of these conditions is present:

- One or more floating domain gate drivers has detected an open-LED fault. In this case, the switch(es) with Open LED faults will remain closed until the IN or EN input is toggled
- One or more floating domain gate drivers has detected a short-LED fault condition
- One or more floating domain gate drivers has detected an open-trace condition
- The EN pin is asserted, but the charge pump voltage is below its minimum rated operating voltage (CP_RDY)
- Thermal Warning
- Thermal Shutdown

Faults are cleared if IN falls below the UVLO or EN falls below the logic low threshold.

LED Open Fault Detection and Protection

An open-LED fault is triggered when the voltage between the individual LED switch DRAIN node and switch SOURCE node exceeds V_{OTH}. The $\overline{\text{FLT}}$ output is driven low and the switch closes for the remainder of the sequence. The fault condition is cleared when the EN pin goes low or IN goes low.

LED Short Detection

A short-LED fault is triggered when the voltage between the switch DRAIN node and the switch SOURCE node is below V_{STH}. V_{STH} is programmable by the A0 resistor setting such that a single LED short can be detected in applications, no matter if 1, 2, or 3 LEDs are used per switch. The fault condition is checked while the corresponding switch is open and current is flowing through the LED or shorted LED segment. Once a short-LED fault has been detected, the $\overline{\text{FLT}}$ output is driven low. No action is taken by the switch in response to detecting a shorted LED. The device will continue the switch sequence with the fault flag asserted. The fault condition is cleared when either the EN input or IN input goes low.

The short-LED fault detection is masked during half of the first T_{SEQ} period, T_{MASK_START}, to prevent false fault flags while the LED driver is starting up. The short-LED fault detection is also masked during the switch transitions at the beginning of each new T_{SEQ} period to prevent the LED driver transients from falsely triggering a fault flag. The mask time during switch transitions depends on the programmed T_{SEQ} value and the programmed FADE setting.

If FADE is not used:

$$T_{\text{MASK_SW}} = 0.0256 \times t_{\text{SEQ}}$$

where T_{MASK_SW} is the mask filter time in ms and t_{SEQ} is the single step sequence period in ms.

If FADE is enabled:

$$T_{\text{MASK_SW}} = 0.034 \times \text{NFADE} \times t_{\text{SEQ}}$$

where NFADE is the fade setting (1, 2, or 3)

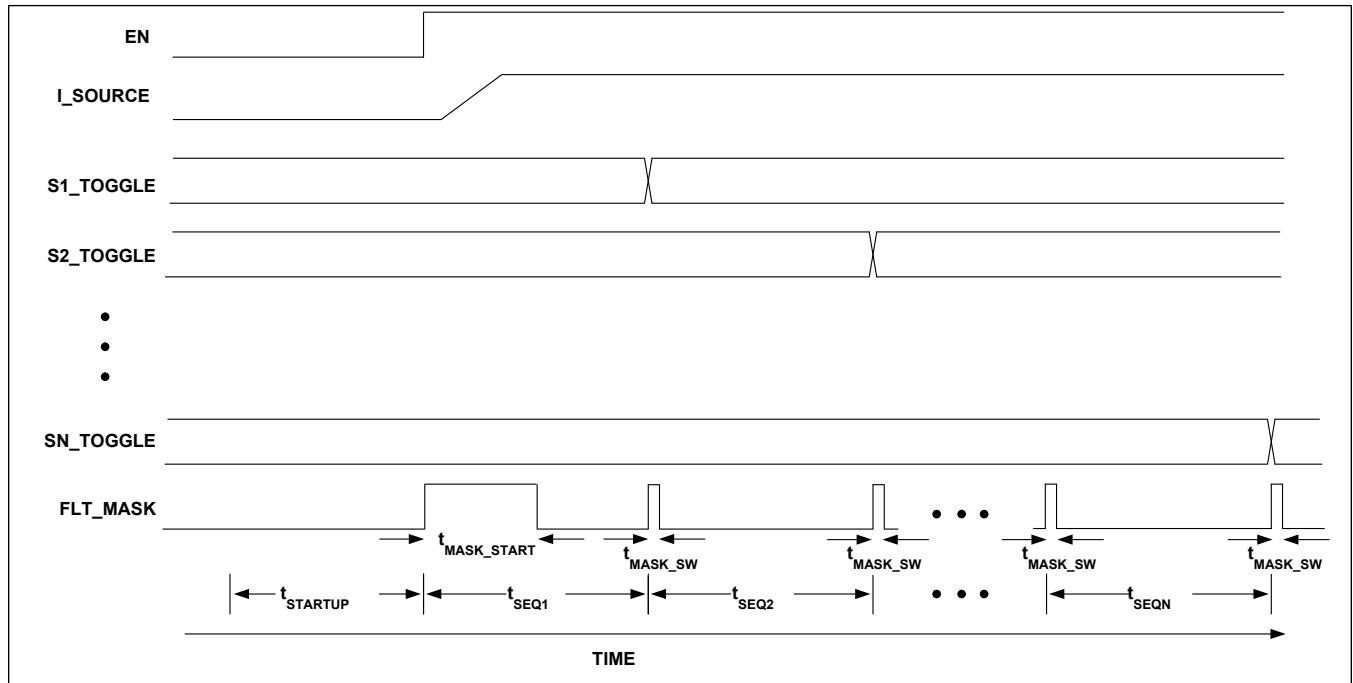

Figure 2. Fault Mask Timing Diagram

Open Trace Detection

An open-trace fault is triggered when the current through the closed switch is less than I_LED_MIN. Once the open-trace fault has been detected, the FLT output is driven low. No action is taken by the switch in response to detecting an open trace. the device will continue the switch sequence with the fault flag asserted. The fault status is cleared when either the EN input or IN input goes low.

The open-trace fault detection is masked during half of the first TSEQ period, T_MASK_START, to prevent false fault flags while the LED driver is starting up. The open-trace fault detection is also masked during the switch transitions at the beginning of each new TSEQ period to prevent the LED driver transients from falsely triggering a fault flag. The mask time during switch transitions depends on the programmed TSEQ value and the programmed FADE setting.

The mask time during switch transitions depends on the programmed TSEQ value and the programmed FADE setting.

If FADE is not used:

$$T_{MASK_SW} = 0.0256 \times t_{SEQ}$$

where T_MASK_SW is the mask filter time in ms and TSEQ is the single step sequence period in ms.

If FADE is enabled:

$$T_{MASK_SW} = 0.034 \times NFADE \times t_{SEQ}$$

where NFADE is the fade setting (1, 2, or 3)

Thermal Protection

The IC features an on-chip temperature-protection circuit to prevent the device from overheating.

When the die temperature rises above the thermal-warning threshold (+140°C), a thermal-warning fault is triggered, causing the FLT pin to be asserted. No action is taken with the switches. Setting the EN pin low will clear the fault status.

If the die temperature is still above the threshold, the fault will re-assert after the EN input goes high.

When the die temperature rises above the thermal-shutdown threshold (+165°C), a thermal-shutdown fault is triggered, causing the $\overline{\text{FLT}}$ pin to be asserted and all switches to close. The thermal-shutdown fault status is reset by power cycling the device.

Applications Information

RCLK Selection

Choose RCLK according to the following equation:

$$RCLK = (t_{SEQ} - 0.17)/1.045$$

Where RCLK is the resistance between CLK and GND in k Ω and t_{SEQ} is the single step sequence period in ms.

Fade

The fade is implemented by pulse-width modulating the switches on and off, and gradually changing the PWM duty cycle from 0% to 100% in the case of dim up or 100% to 0% in the case of dim down. In applications where the fade effect is enabled, the LED driver should be chosen to have a fast enough transient response to handle the PWM switching of the sequencing device. If fade is not used, then the transient requirements of the LED driver are less stringent.

For applications where fade is not used, the MAX25611A LED driver is recommended. For applications with fade, the MAX20078 or MAX25601 should be considered.

Hazard Light

A hazard lighting function can be implemented two different ways. The first method is to pull the EN input low. This will disable the sequence and force all the switches open so that the LED driver current flows through all the LEDs. Because the fault-detection algorithm requires the switch transition to recognize fault conditions, the fault-detection block is disabled in this mode.

A second method of implementing a hazard light is to add a small signal MOSFET to temporarily short out a portion of the RCLK resistor. This speeds up the sequence such that it appears the LEDs turn on at the same time, although they are still being sequenced one by one. This allows the fault-detection block to remain active. A sequence time of between 2ms and 3ms is recommended. Refer to the MAX25605 Evaluation Kit for an example. This method is applicable only when the device is programmed to dim up.

Example Sequential Turn Signal

For certain designs, it may be required that some LEDs are sequenced, while other LEDs turn on simultaneously (non-sequenced). [Figure 3](#) and [Figure 4](#) show an example application circuit and timing diagram, which demonstrate such a design.

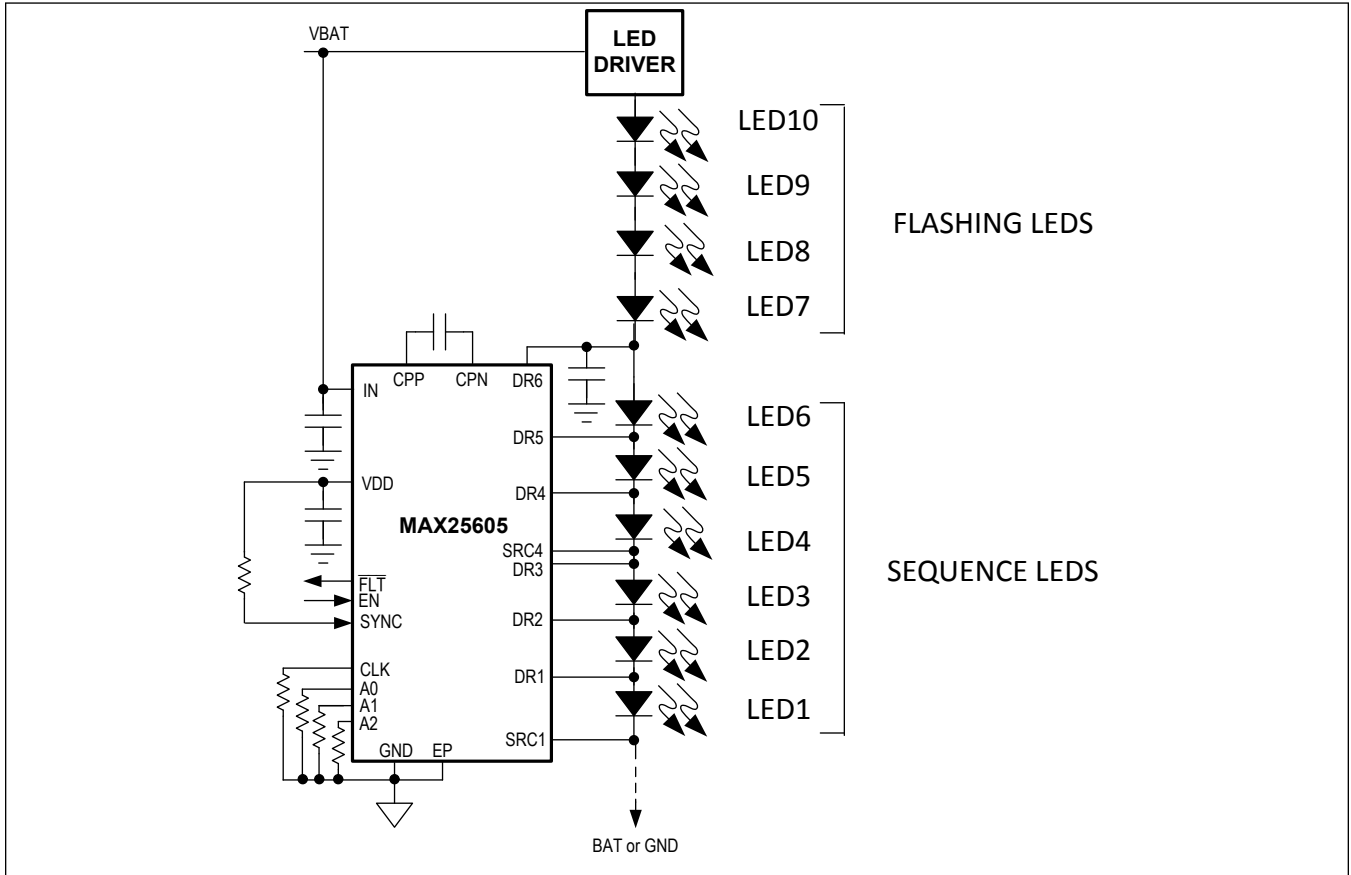
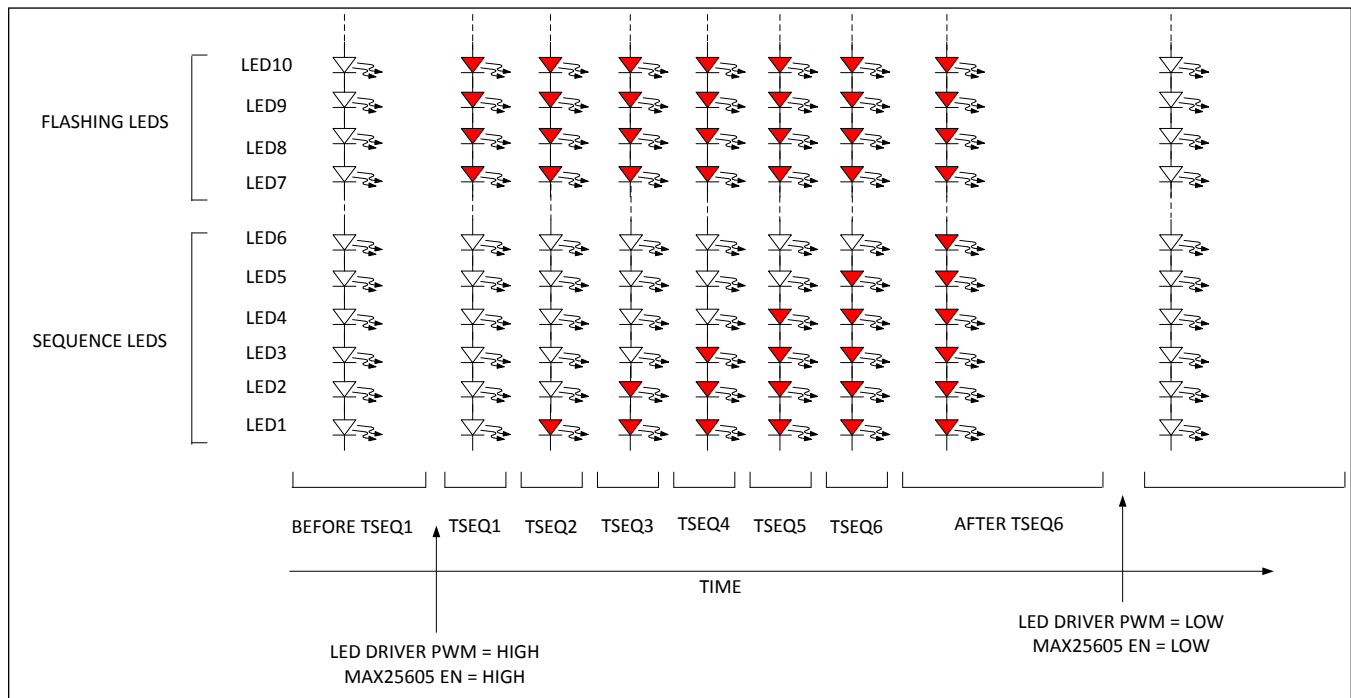

Figure 3. Example Application Circuit



Lighting Sequence Corresponding to the Figure 4. Circuit

DR_ Leakage Current

The DR_ pins have some leakage current on the order of a few microamps. If the LED driver is off while the MAX25605 is powered, there is the possibility that the LEDs will be very weakly illuminated by the leakage current. In applications where this is a concern, resistors can be added in parallel with the LEDs to shunt the microamp leakage and keep the LEDs off.

Thermal Considerations

Heat is primarily transferred from the IC to the PCB through the exposed pad. Connect the exposed pad to a large, solid ground plane.

Layout Considerations

1. Connect the IN, V_{DD}, CPP/CPN, and DR6 decoupling caps as close as possible to the IC.
2. Connect the exposed pad to a large, solid ground plane. The exposed pad is the primary path for heat to escape the device.

Typical Application Circuits

Typical Applications Circuit

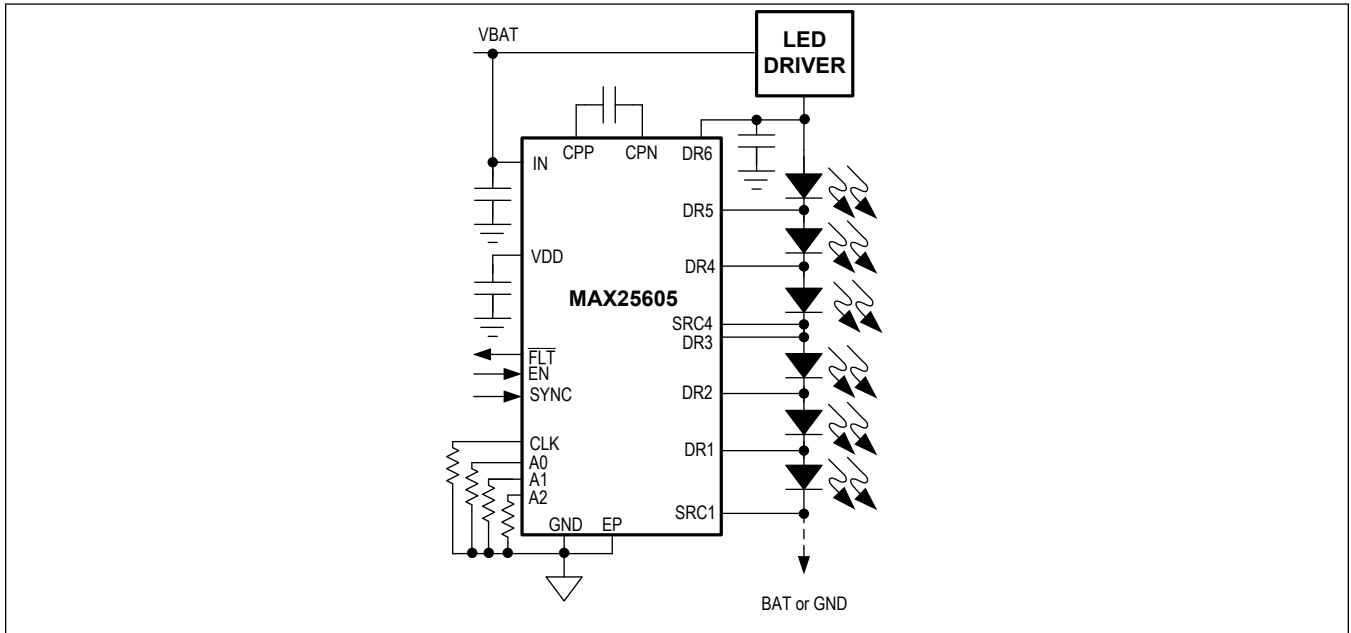

Typical Application Circuits (continued)

12 Segment Design from a Single LED Driver

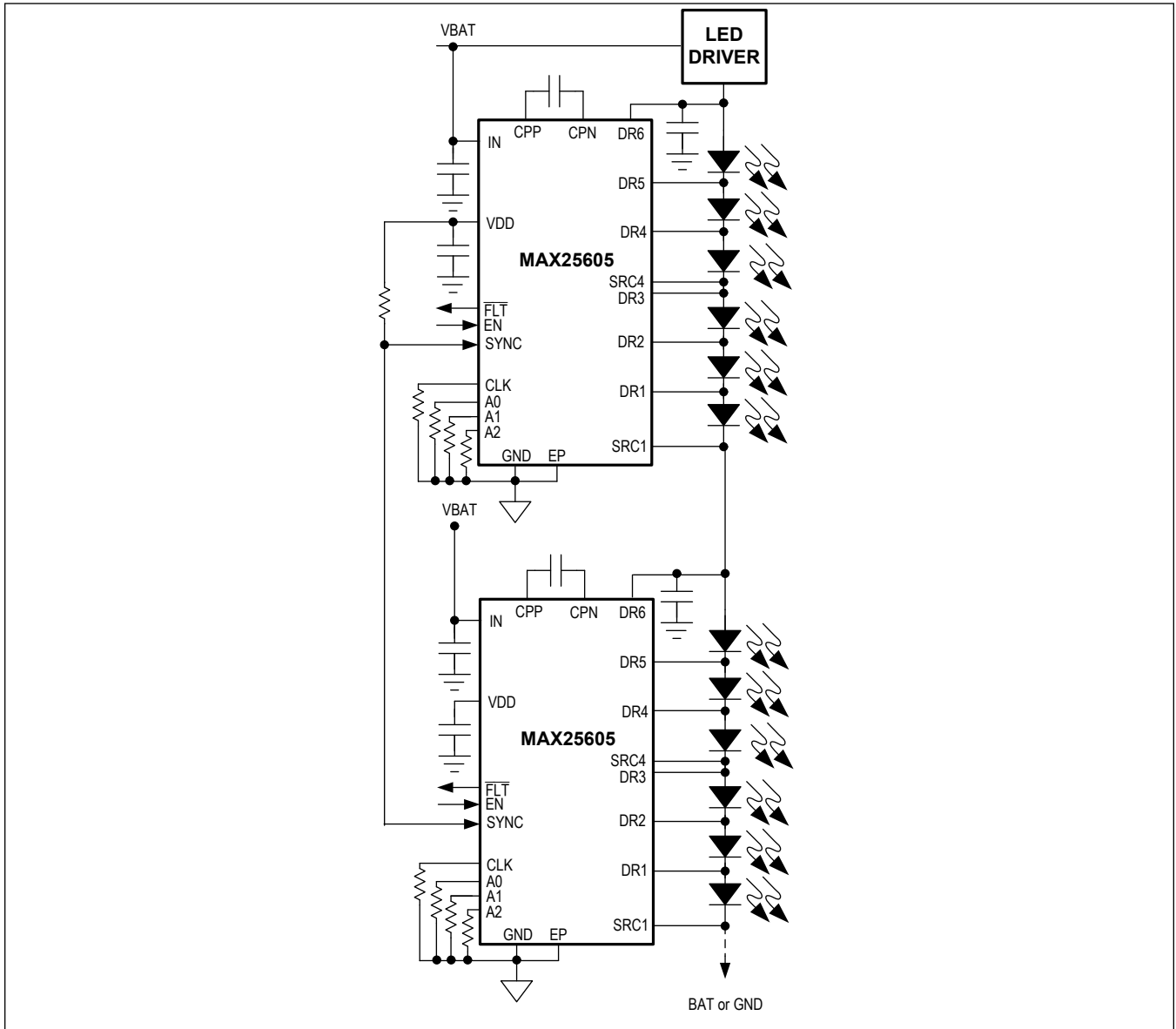

Typical Application Circuits (continued)

12 Segment Applications Circuit with Separate LED Drivers

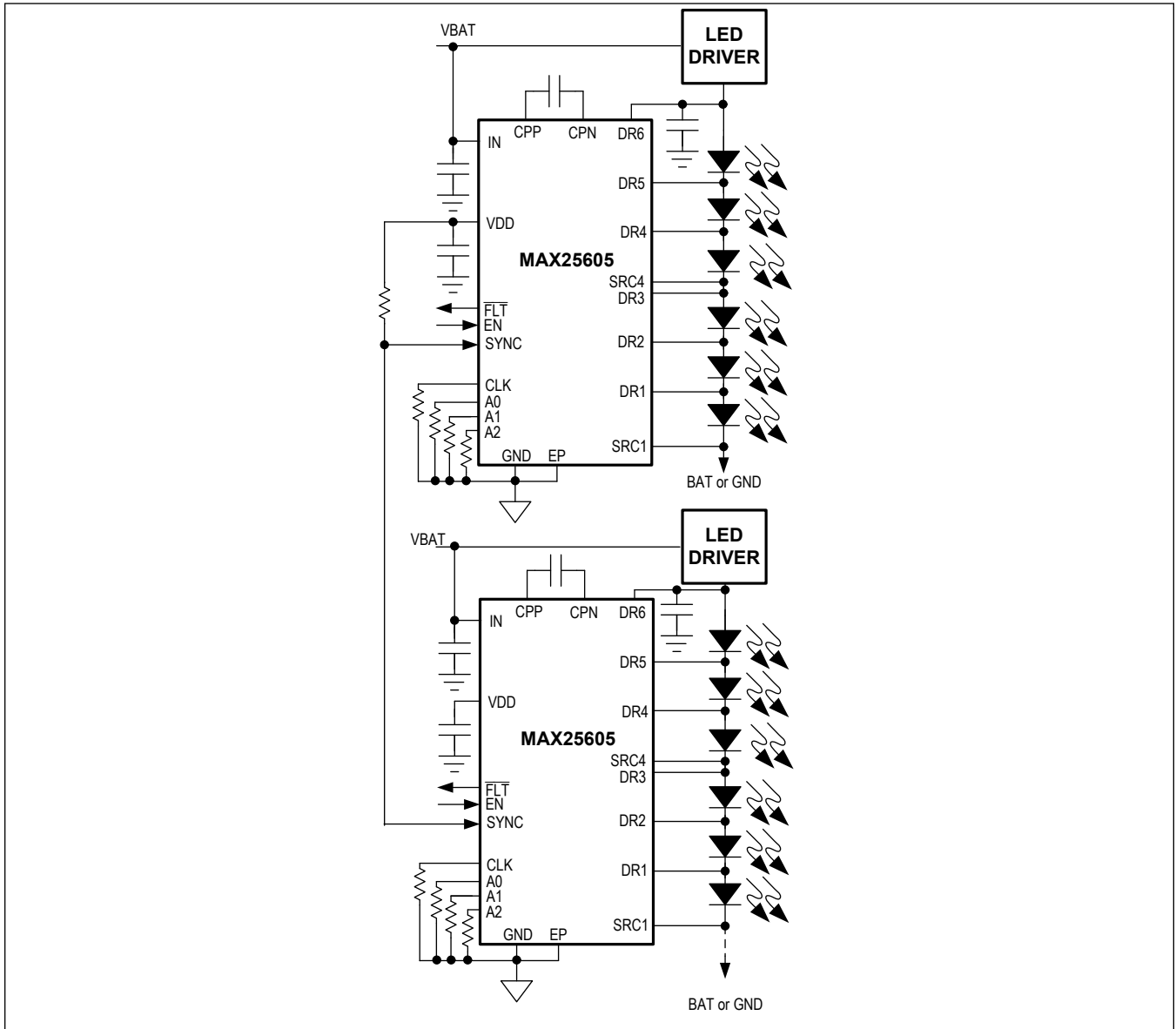

Typical Application Circuits (continued)

Five Segment Applications Circuit

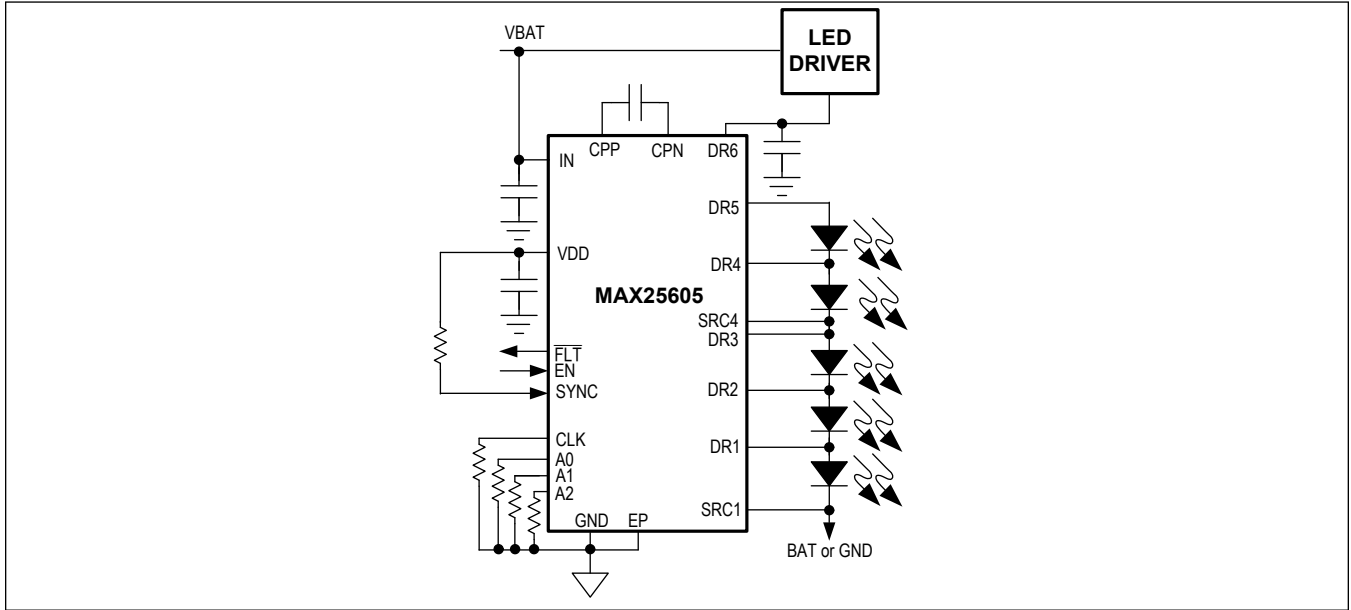

Four Segment Applications Circuit

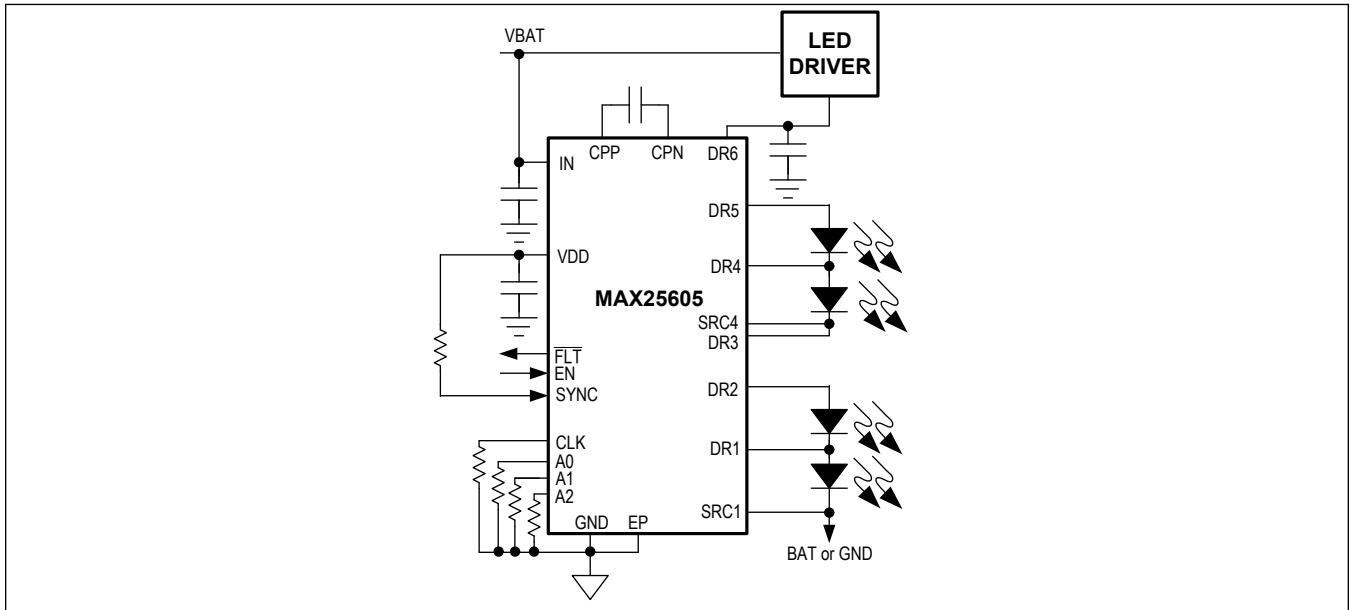

Typical Application Circuits (continued)

Three Segment Applications Circuit

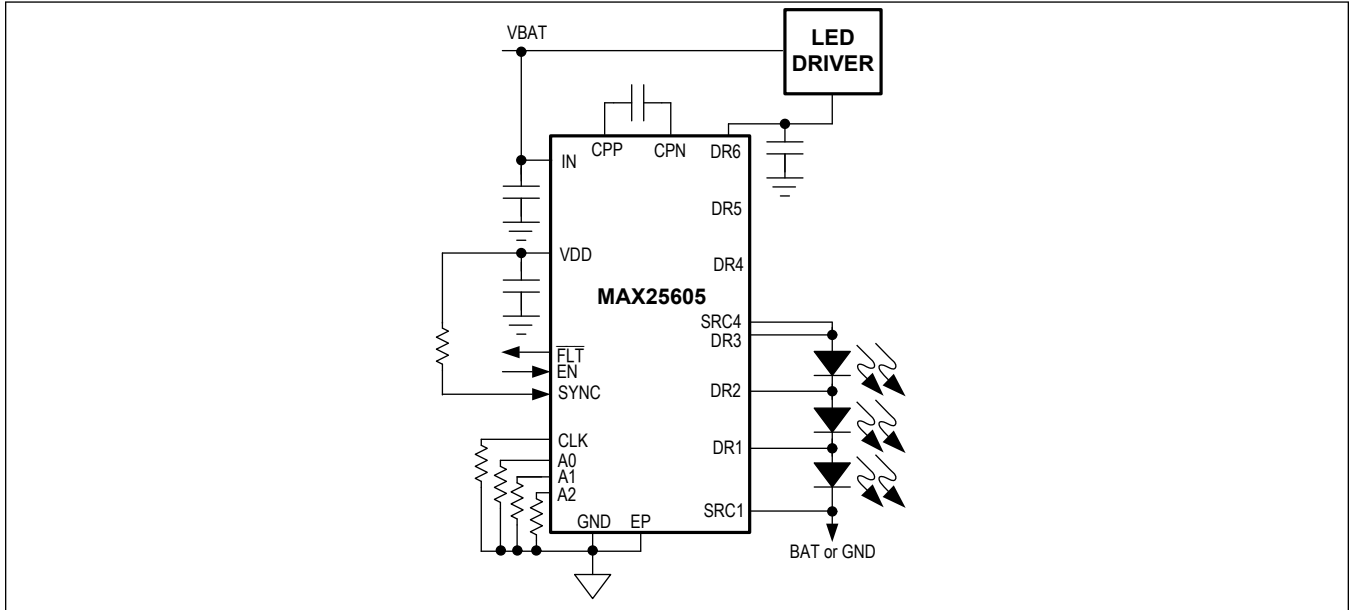

Ordering Information

Part Number	Temp Range	Pin-Package
MAX25605ATP/VY+	-40°C to +125°C	20 TQFN-EP (SW)*
MAX25605AUP/V+	-40°C to +125°C	20 TSSOP-EP*

N denotes an automotive-qualified part.

+ Denotes a lead(Pb)-free/RoHS-compliant package.

*EP = Exposed pad.

(SW) = Side wettable.

Revision History

REVISION NUMBER	REVISION DATE	DESCRIPTION	PAGES CHANGED
0	6/20	Initial release	—
1	11/20	Updated Electrical Characteristics , Ordering Information	7, 8, 27

For pricing, delivery, and ordering information, please visit Maxim Integrated's online storefront at <https://www.maximintegrated.com/en/storefront/storefront.html>.

Maxim Integrated cannot assume responsibility for use of any circuitry other than circuitry entirely embodied in a Maxim Integrated product. No circuit patent licenses are implied. Maxim Integrated reserves the right to change the circuitry and specifications without notice at any time. The parametric values (min and max limits) shown in the Electrical Characteristics table are guaranteed. Other parametric values quoted in this data sheet are provided for guidance.

X-ON Electronics

Largest Supplier of Electrical and Electronic Components

Click to view similar products for [LED Lighting Drivers](#) category:

Click to view products by [Maxim](#) manufacturer:

Other Similar products are found below :

[LV5235V-MPB-H](#) [MB39C602PNF-G-JNEFE1](#) [MIC2871YMK-T5](#) [AL1676-10BS7-13](#) [AL1676-20AS7-13](#) [AP5726WUG-7](#) [MX877RTR](#)
[ICL8201](#) [IS31BL3228B-UTLS2-TR](#) [IS31BL3506B-TTLS2-TR](#) [AL3157F-7](#) [AP5725FDCG-7](#) [AP5726FDCG-7](#) [LV52204MTTBG](#)
[AP5725WUG-7](#) [STP4CMPQTR](#) [NCL30086BDR2G](#) [CAT4004BHU2-GT3](#) [LV52207AXA-VH](#) [AP1694AS-13](#) [TLE4242EJ](#) [AS3688](#)
[IS31LT3172-GRLS4-TR](#) [TLD2311EL](#) [KTD2694EDQ-TR](#) [KTZ8864EJAA-TR](#) [IS32LT3174-GRLA3-TR](#) [ZXLD1374QESTTC](#) [MP2488DN-](#)
[LF-Z](#) [NLM0010XTSA1](#) [AL1676-20BS7-13](#) [MPQ7220GF-AEC1-P](#) [MPQ4425BGJ-AEC1-P](#) [MPQ7220GF-AEC1-Z](#) [MPQ4425BGJ-AEC1-Z](#)
[IS31FL3737B-QFLS4-TR](#) [IS31FL3239-QFLS4-TR](#) [KTD2058EUAC-TR](#) [KTD2037EWE-TR](#) [DIO5662ST6](#) [IS31BL3508A-TTLS2-TR](#)
[MAX20052CATC/V+](#) [MAX25606AUP/V+](#) [BD6586MUV-E2](#) [BD9206EFV-E2](#) [BD9416FS-E2](#) [LYT4227E](#) [LYT6079C-TL](#) [MP3394SGF-P](#)
[MP4689AGN-P](#)