



## MAX2605–MAX2609 Evaluation Kits

### General Description

The MAX2605–MAX2609 evaluation kits (EV kits) simplify evaluation of this family of voltage-controlled oscillators (VCOs). These kits enable testing of the devices' performance and require no additional support circuitry. Both signal outputs use SMA connectors to facilitate connection to RF test equipment.

These EV kits are fully assembled and tested. Their oscillation frequencies are set to approximately the midrange of the respective VCOs.

### Component Suppliers

SUPPLIER	PHONE	FAX	WEBSITE
AVX	803-946-0690	803-626-3123	avx-corp.com
Coilcraft	847-639-6400	847-639-1469	coilcraft.com
EFJohnson	402-474-4800	402-474-4858	efjohnson.com
Murata	814-237-1431	814-238-0490	murata.com

### MAX2605 Component List

DESIGNATION	QTY	DESCRIPTION
C1, C4	2	1000pF $\pm 5\%$ ceramic capacitors (0603) Murata GRM39COH102J025A or AVX 06035A102JAT2A
C2, C3	2	12pF $\pm 5\%$ ceramic capacitors (0603) Murata GRM39COG120J050A
C5	1	10 $\mu$ F $\pm 10\%$ , 16V tantalum capacitor AVX TAJC106K016
R1	1	270 $\Omega$ $\pm 5\%$ resistor (0603)
R2, R3	2	Not installed
R4	1	10 $\Omega$ $\pm 5\%$ resistor (0603)
L1, L2	2	Not installed
L4, L5	2	680nH inductors Coilcraft 1008CS-681XJBC
L3	1	1.2 $\mu$ H inductor Coilcraft 1206CS-122XJBC
U1	1	MAX2605EUT
J1, J2	2	SMA connectors (edge mount) EFJohnson 142-0701-801 or Digi-Key J502-ND
VCC,GND, TUNE	6	Test points Digi-Key 5000K-ND
None	1	MAX2605/6/7 EV kit circuit board
None	1	MAX2605–MAX2609 data sheet

### Features

- ◆ Easy Evaluation
- ◆ Complete, Tunable VCO Test Board with Tank Circuit
- ◆ Low Phase Noise
- ◆ Fully Assembled and Tested

### Ordering Information

PART	TEMP. RANGE	IC PACKAGE
MAX2605EVKIT	-40°C to +85°C	6 SOT23-6
MAX2606EVKIT	-40°C to +85°C	6 SOT23-6
MAX2607EVKIT	-40°C to +85°C	6 SOT23-6
MAX2608EVKIT	-40°C to +85°C	6 SOT23-6
MAX2609EVKIT	-40°C to +85°C	6 SOT23-6

### MAX2606 Component List

DESIGNATION	QTY	DESCRIPTION
C1, C4	2	1000pF $\pm 5\%$ ceramic capacitors (0603) Murata GRM39COH102J025A or AVX 06035A102JAT2A
C2, C3	2	4.7pF $\pm 0.25\%$ ceramic capacitors (0603) Murata GRM39COG4R7C050A
C5	1	10 $\mu$ F $\pm 10\%$ , 16V tantalum capacitor AVX TAJC106K016
R1	1	270 $\Omega$ $\pm 5\%$ resistor (0603)
R2, R3	2	Not installed
R4	1	10 $\Omega$ $\pm 5\%$ resistor (0603)
L1, L2	2	Not installed
L3	1	270nH $\pm 2\%$ inductor Coilcraft 1008CS-271XJBC
L4, L5	2	330nH inductor Coilcraft 1008CS-331XJBC
U1	1	MAX2606EUT
J1, J2	2	SMA connectors (edge mount) EFJohnson 142-0701-801 or Digi-Key J502-ND
VCC,GND, TUNE	6	Test points
None	1	MAX2605/6/7 EV kit circuit board
None	1	MAX2605–MAX2609 data sheet

Evaluate: MAX2605–MAX2609

# MAX2605–MAX2609 Evaluation Kits

## MAX2607 Component List

DESIGNATION	QTY	DESCRIPTION
C1, C4	2	1000pF ±5% ceramic capacitors (0603) Murata GRM39COH102J025A or AVX 06035A102JAT2A
C2, C3	2	3pF ±0.25% ceramic capacitors (0603) Murata GRM39COG030C050A
C5	1	10µF ±10%, 16V tantalum capacitor AVX TAJC106K016
R1	1	270Ω ±5% resistor (0603)
R2, R3	2	Not installed
R4	1	10Ω ±5% resistor (0603)
L1, L2	2	Not installed
L3	1	68nH ±2% inductor Coilcraft 1008CS-680XJBC
L4, L5	2	120nH inductors Coilcraft 1008CS-121XJBC
U1	1	MAX2607EUT
J1, J2	2	SMA connectors (edge mount) EFJohnson 142-0701-801 or Digi-Key J502-ND
VCC,GND, TUNE	6	Test points
None	1	MAX2605/6/7 EV kit circuit board
None	1	MAX2605–MAX2609 data sheet

## MAX2608 Component List

DESIGNATION	QTY	DESCRIPTION
C1	1	1000pF ±5% ceramic capacitor (0603) Murata GRM39COH102J025A or AVX 06035A102JAT2A
C2, C3	2	1pF ±0.25% ceramic capacitors (0603) Murata GRM39COG010C050A
C4, C6	2	100pF ±5% ceramic capacitors (0603) Murata GRM39COG101J050A
C5	1	10µF ±10%, 16V tantalum capacitor AVX TAJC106K016
R1	1	270Ω ±5% resistor (0603)
R2, R3	2	Not installed
R4	1	10Ω ±5% resistor (0603)
L1	1	22nH ±2% inductor Coilcraft 0805CS-220XGBC
L4, L5	2	68nH ±2% inductors Coilcraft 0805CS-680XJBC
U1	1	MAX2608EUT
J1, J2	2	SMA connectors (edge mount) EFJohnson 142-0701-801 or Digi-Key J502-ND
VCC,GND, TUNE	6	Test points Digi-Key 5000K-ND
None	1	MAX2608/9 EV kit circuit board
None	1	MAX2605–MAX2609 data sheet

### Quick Start

The MAX2605–MAX2609 evaluation kits are fully assembled and factory tested. Follow the instructions in the *Connections and Setup* section for proper device evaluation.

#### Test Equipment Required

- Low-noise power supplies (these are recommended for oscillator noise measurement). Noise or ripple will frequency-modulate the oscillator and cause spectral spreading. Batteries can be used in place of power supplies, if necessary.
  - Use a DC power supply capable of supplying +2.7V to +5.5V. Alternatively, use two or three 1.5V batteries.

– Use a DC power supply capable of supplying +0.4V to +2.4V, continuously variable, for TUNE. Alternatively, use two 1.5V batteries with a resistive voltage divider or potentiometer.

- An RF spectrum analyzer that covers the operating frequency range of the MAX2605–MAX2609
- A 50Ω coaxial cable with SMA connectors
- An ammeter (optional)

#### Connections and Setup

- 1) Connect a DC supply (preset to +3V) to the VCC and GND terminals (through an ammeter, if desired) on the EV kit.
- 2) Turn on the DC supply. If used, the ammeter reading

# MAX2605–MAX2609 Evaluation Kits

**Evaluate: MAX2605–MAX2609**

## MAX2609 Component List

DESIGNATION	QTY	DESCRIPTION
C1	1	1000pF ±5% ceramic capacitors (0603) Murata GRM39COH102J025A or AVX 06035A102JAT2A
C2, C3	2	1pF ±0.25% ceramic capacitors (0603) Murata GRM39COG010C050A
C4, C6	2	100pF ±5% ceramic capacitors (0603) Murata GRM39COG101J050A
C5	1	10μF ±10%, 16V tantalum capacitor AVX TAJC106K016
R1	1	270Ω ±5% resistor (0603)
R2, R3	2	Not installed
R4	1	10Ω ±5% resistor (0603)
L1	1	8.2nH ±2% inductor Coilcraft 0805CS-080XGBC
L4, L5	2	27nH ±2% inductors Coilcraft 0805CS-270XJBC
U1	1	MAX2609EUT
J1, J2	2	SMA connectors (edge mount) EFJohnson 142-0701-801 or Digi-Key J502-ND
VCC, GND, TUNE	6	Test points Digi-Key 5000K-ND
None	1	MAX2608/9 EV kit circuit board
None	1	MAX2605–MAX2609 data sheet

approximates the typical operating current specified in the MAX2605–MAX2609 data sheet.

- 3) Connect the VCO output (OUT+ or OUT-) to a spectrum analyzer with a 50Ω coaxial cable.
- 4) Apply a positive variable DC voltage between 0.4V and 2.4V to TUNE.
- 5) Check the tuning bandwidth on the spectrum analyzer by varying the tuning voltage (+0.4V to +2.4V).

### Layout Considerations

The EV kit PC board can serve as a guide for laying out a board using the MAX2605–MAX2609. Generally, the VCC pin on the PC board should have a decoupling capacitor placed close to the IC. This minimizes noise

coupling from the supply. Also, place the VCO as far away as possible from the noisy section of a larger system, such as a switching regulator or digital circuits.

The VCO's performance is strongly dependent on the availability of the external tuning inductor. For best performance, use high-Q components and choose their values carefully. To minimize the effects of parasitic elements, which degrade circuit performance, place the tuning inductor and C<sub>BYP</sub> close to the VCO. For higher-frequency versions, include the parasitic PC board inductance and capacitance when calculating the oscillation frequency. In addition, remove the ground plane around and under the tuning inductor to minimize the effect of parasitic capacitance.

Noise on TUNE translates into FM noise on the outputs; therefore, keep the trace between TUNE and the control circuitry as short as possible. If necessary, use an RC filter to further suppress noise, as done on the EV kits.

# MAX2605-MAX2609 Evaluation Kits

**Evaluate: MAX2605-MAX2609**

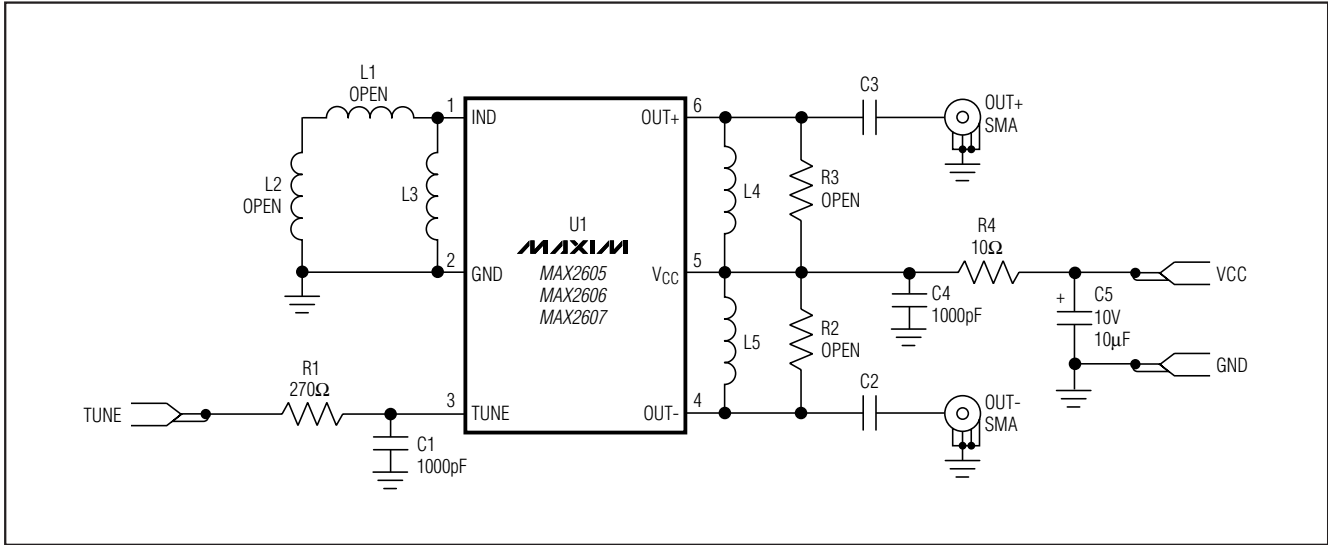

Figure 1. MAX2605/MAX2606/MAX2607 EV Kits Schematic

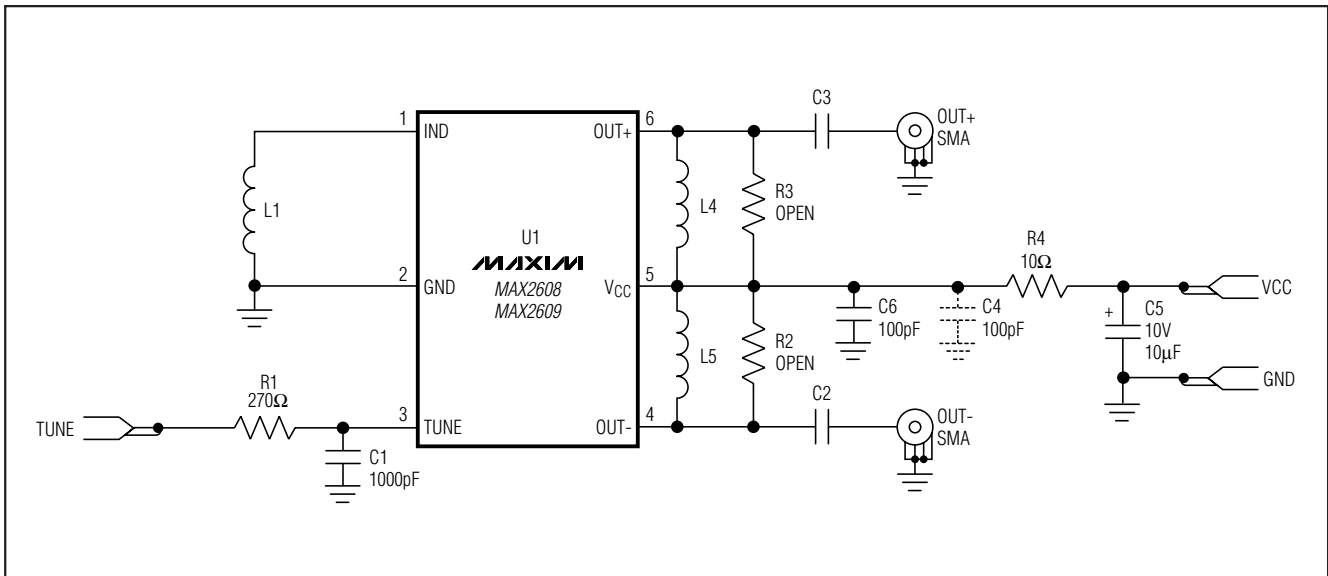

Figure 2. MAX2608/MAX2609 EV Kits Schematic

# MAX2605-MAX2609 Evaluation Kits

**Evaluate: MAX2605-MAX2609**

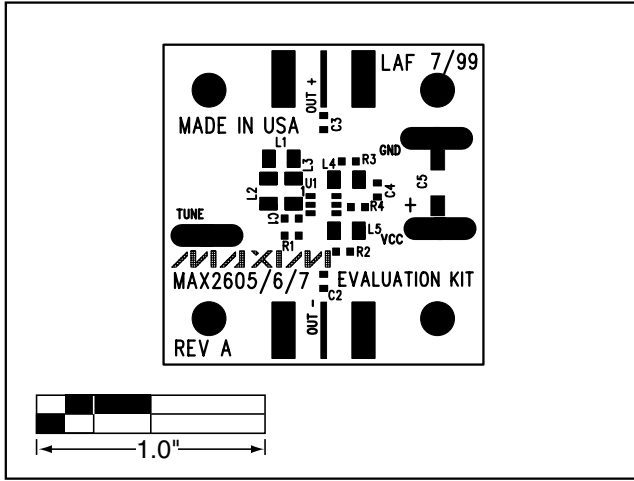

Figure 3. MAX2605/MAX2606/MAX2607 EV Kits Component Placement Guide—Top Silk Screen

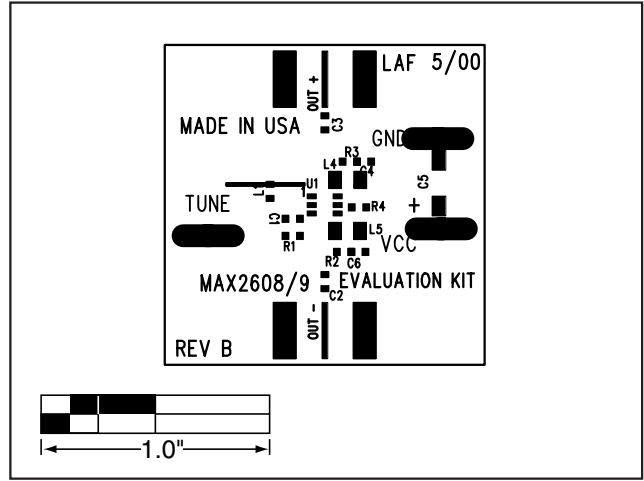

Figure 4. MAX2608/MAX2609 EV Kits Component Placement Guide—Top Silk Screen

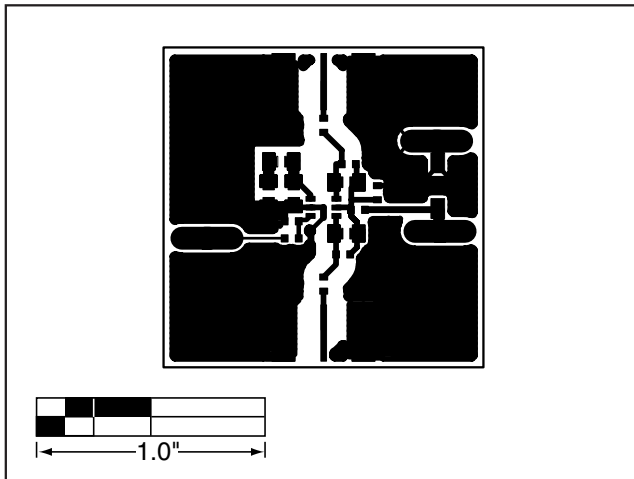

Figure 5. MAX2605/MAX2606/MAX2607 EV Kits PC Board Layout—Component Side

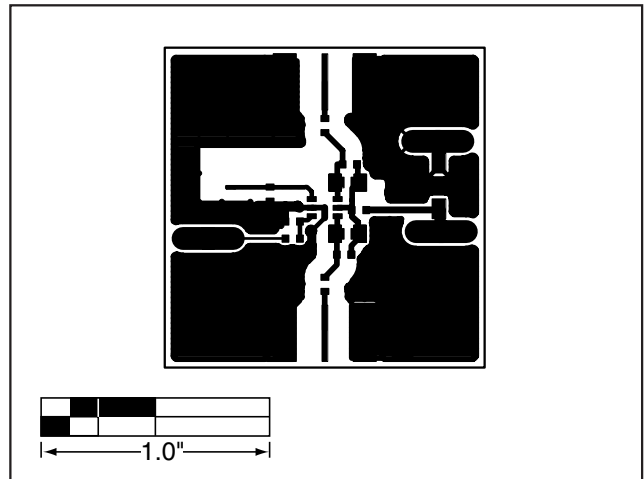

Figure 6. MAX2608/MAX2609 EV Kits PC Board Layout—Component Side

# MAX2605–MAX2609 Evaluation Kits

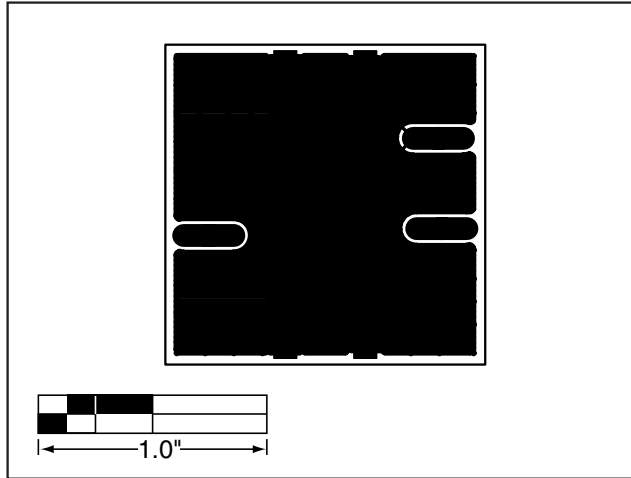

Figure 7. MAX2605/MAX2606/MAX2607/MAX2608/MAX2609 EV Kits PC Board Layout—Ground Plane

Maxim cannot assume responsibility for use of any circuitry other than circuitry entirely embodied in a Maxim product. No circuit patent licenses are implied. Maxim reserves the right to change the circuitry and specifications without notice at any time.

6 \_\_\_\_\_ **Maxim Integrated Products, 120 San Gabriel Drive, Sunnyvale, CA 94086 408-737-7600**

## X-ON Electronics

Largest Supplier of Electrical and Electronic Components

*Click to view similar products for [Clock & Timer Development Tools](#) category:*

*Click to view products by [Maxim](#) manufacturer:*

Other Similar products are found below :

[AD9530/PCBZ](#) [DSC400-0333Q0032KE1-EVB](#) [TDGL013](#) [ADCLK946/PCBZ](#) [EKIT01-HMC1032LP6G](#) [RV-2251-C3-EVALUATION-BOARD](#) [RV-3029-C2-EVALUATION-BOARD-OPTION-B](#) [SKY72310-11-EVB](#) [EV1HMC6475LC4B](#) [EV1HMC8364LP6G](#) [EV1HMC8362LP6G](#) [RV-8263-C7-EVALUATION-BOARD](#) [EVK9FGV1002](#) [EVK9FGV1008](#) [EV1HMC6832ALP5L](#) [EVAL01-HMC911LC4B](#) [EVAL01-HMC987LP5E](#) [EVAL01-HMC988LP3E](#) [TS3002DB](#) [125605-HMC702LP6CE](#) [MIKROE-2481](#) [2045](#) [EKIT01-HMC835LP6G](#) [EKIT01-HMC834LP6GE](#) [TS3006DB](#) [105811-HMC440QS16G](#) [DSC-TIMEFLASH2-KIT1](#) [110227-HMC510LP5](#) [110227-HMC513LP5](#) [AD9515/PCBZ](#) [AC164147](#) [DFR0469](#) [127102-HMC856LC5](#) [127270-HMC765LP6CE](#) [127272-HMC783LP6CE](#) [127283-HMC807LP6CE](#) [127900-HMC765LP6CE](#) [129021-HMC838LP6CE](#) [ADM00791](#) [DC2254A-B](#) [3296](#) [DC1959A-C](#) [DC2254A-A](#) [DC1562B-G](#) [DC2073A-G](#) [129020-HMC838LP6CE](#) [129467-HMC820LP6CE](#) [129470-HMC821LP6CE](#) [129472-HMC822LP6CE](#) [129874-HMC910LC4B](#)