

Click [here](#) for production status of specific part numbers.

## MAX2679/MAX2679B

## GPS/GNSS Ultra-Low Current Low-Noise Amplifier

### General Description

The MAX2679 and MAX2679B low-noise amplifiers (LNA) are designed for GPS L1, Galileo, and GLONASS applications. The devices achieve high gain and low noise figure while maximizing the input-referred 1dB compression point and the 3rd-order intercept point. The MAX2679 achieves excellent performance while consuming only 1mA supply current and providing 0.95dB noise figure. The MAX2679B achieves excellent performance while consuming only 650 $\mu$ A and providing 1.03dB noise figure. The MAX2679/MAX2679B operates from a +1.08V to +1.98V single supply. The devices are available in a very small, lead-free, RoHS-compliant, 0.83mm x 0.83mm wafer-level package (WLP).

### Applications

- Wearables
- Telematics (Asset Tracking and Management)
- Cellular Phones with GPS
- Notebook PCs/Ultra-Mobile PCs
- Recreational Navigation
- Watches
- Digital Cameras
- GPS Front End Modules

### Benefits and Features

- High Power Gain: 19dB (MAX2679), 16.5dB (MAX2679B)
- Low Noise Figure: 0.95dB (MAX2679), 1.03dB (MAX2679B)
- Integrated 50 $\Omega$  Output Matching Circuit
- Low Supply Current: 1mA (MAX2679), 650 $\mu$ A (MAX2679B)
- Wide Supply Voltage Range: 1.08V to 1.98V
- Low Bill of Materials: One Inductor, Two Capacitors, One Resistor
- 4-Bump, 0.4mm Pitch WLP, 0.83mm x 0.83mm

**Ordering Information** appears at end of data sheet.

### Simplified Block Diagram

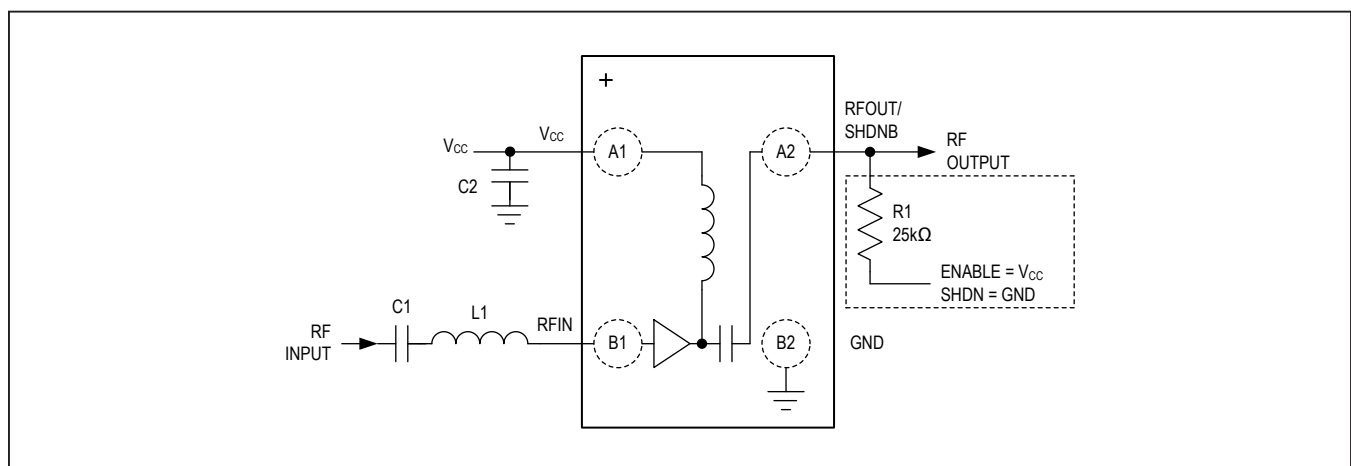

**Absolute Maximum Ratings**

V <sub>CC</sub> to GND .....	-0.3V to 2.2V	Operating Temperature Range.....	-40°C to +85°C
Other Pins to GND .....	-0.3V to V <sub>CC</sub> + 0.3V	Junction Temperature.....	+150°C
Maximum RF Input Power.....	+5dBm	Storage Temperature Range .....	-65°C to +160°C
Continuous Power Dissipation (Multilayer Board)		Lead Temperature (soldering, 10s) .....	Reflow Profile (Note 1)
(T <sub>A</sub> = +70°C, derate 9.7mW/°C above +70°C.).....	776mW	Soldering Temperature (reflow).....	+260°C

**Note 1:** Refer to MAXIM Application Note 1891: Wafer-Level Packaging (WLP) and Its Applications.

Stresses beyond those listed under "Absolute Maximum Ratings" may cause permanent damage to the device. These are stress ratings only, and functional operation of the device at these or any other conditions beyond those indicated in the operational sections of the specifications is not implied. Exposure to absolute maximum rating conditions for extended periods may affect device reliability.

**Package Information**

**WLP 0.4mm**

<b>PACKAGE CODE</b>	<b>N40D0+1</b>
Outline Number	<a href="#">21-100107</a>
Land Pattern Number	<a href="#">Refer to Application Note 1891</a>
<b>Thermal Resistance, Four-Layer Board:</b>	
Junction to Ambient (θ <sub>JA</sub> )	102.59°C/W
Junction to Case (θ <sub>JC</sub> )	N/A

For the latest package outline information and land patterns (footprints), go to [www.maximintegrated.com/packages](http://www.maximintegrated.com/packages). Note that a "+", "#", or "-" in the package code indicates RoHS status only. Package drawings may show a different suffix character, but the drawing pertains to the package regardless of RoHS status.

Package thermal resistances were obtained using the method described in JEDEC specification JESD51-7, using a four-layer board. For detailed information on package thermal considerations, refer to [www.maximintegrated.com/thermal-tutorial](http://www.maximintegrated.com/thermal-tutorial).

**Electrical Characteristics**

(V<sub>CC</sub> = 1.08V to 1.98V, T<sub>A</sub> = -40°C to +85°C. Typical values are at V<sub>CC</sub> = 1.8V and T<sub>A</sub> = +25°C, unless otherwise noted. Limits are 100% tested at T<sub>A</sub> = +25°C. Limits over the operating temperature range and relevant supply voltage range are guaranteed by design and characterization. Specifications marked "GBD" are guaranteed by design and not production tested.)

PARAMETER	SYMBOL	CONDITIONS	MIN	TYP	MAX	UNITS
<b>DC ELECTRICAL CHARACTERISTICS</b>						
Supply Voltage	V <sub>CC</sub>		1.08	1.8	1.98	V
Supply Current	I <sub>VCC</sub>	Normal Operation	MAX2679	1000		μA
			MAX2679B	650		
	I <sub>SHDN</sub>	Shutdown Mode, V <sub>RFOUT</sub> /SHDNB = 0V		0	6	
Digital Input Logic-High	V <sub>IH</sub>		0.7 x V <sub>CC</sub>			V
Digital Input Logic-Low	V <sub>IL</sub>				0.3 x V <sub>CC</sub>	V
Digital Input Current Logic-High	I <sub>IH</sub>	At V <sub>IH</sub>		0		μA
Digital Input Current Logic-Low	I <sub>IL</sub>	At V <sub>IL</sub>		0		μA

**Electrical Characteristics (continued)**

( $V_{CC} = 1.08V$  to  $1.98V$ ,  $T_A = -40^{\circ}C$  to  $+85^{\circ}C$ . Typical values are at  $V_{CC} = 1.8V$  and  $T_A = +25^{\circ}C$ , unless otherwise noted. Limits are 100% tested at  $T_A = +25^{\circ}C$ . Limits over the operating temperature range and relevant supply voltage range are guaranteed by design and characterization. Specifications marked "GBD" are guaranteed by design and not production tested.)

PARAMETER	SYMBOL	CONDITIONS		MIN	TYP	MAX	UNITS
<b>AC ELECTRICAL CHARACTERISTICS</b>							
RF Frequency	$f_{RF}$				1575.42		MHz
Power Gain		MAX2679			19		dB
		MAX2679B			16.5		
Noise Figure		0402 matching inductor (Note 2)	MAX2679		0.95		dB
			MAX2679B		1.03		
Out-of-Band 3rd-Order Input Intercept Point	$O_{IP3}$	$f_{RF1} = 1713MHz;$ $PRF1 = -27dBm;$ $f_{RF2} = 1851MHz;$ $PRF2 = -39dBm$	MAX2679		-17		dBm
			MAX2679B		-19		
Input 1dB Compression Point	$P_{1dB}$	$f_{RF} = 1575.42MHz$	MAX2679		-25		dBm
			MAX2679B		-26		
Input Return Loss	$P_{1dB}$	$f_{RF} = 1575.42MHz$	MAX2679		9		dB
			MAX2679B		7		
Output Return Loss					12		dB
Reverse Isolation					26		dB

**Note 2:** Noise figure measured in a Faraday cage to remove all interfering signals from increasing the noise floor. Includes 0.02dB loss of EV Kit trace.

**Typical Operating Characteristics**

$V_{CC} = RFOUT/SHDNB = 1.8V$  and  $T_A = +25^{\circ}C$ , at 1575.42MHz unless otherwise noted.

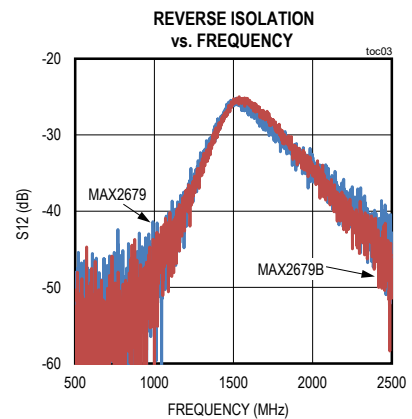
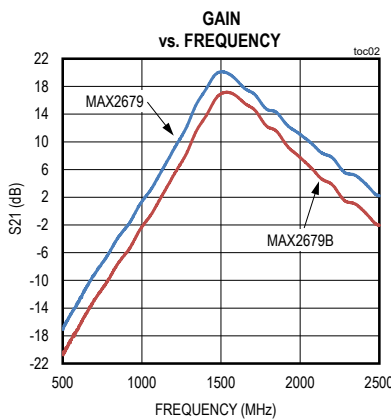
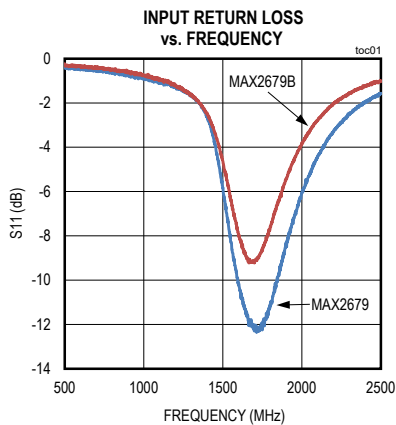

Typical Operating Characteristics (continued)

$V_{CC} = R_{FOUT}/SHDNB = 1.8V$  and  $T_A = +25^{\circ}C$ , at 1575.42MHz unless otherwise noted.

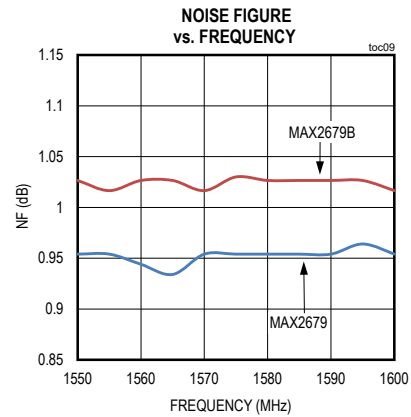
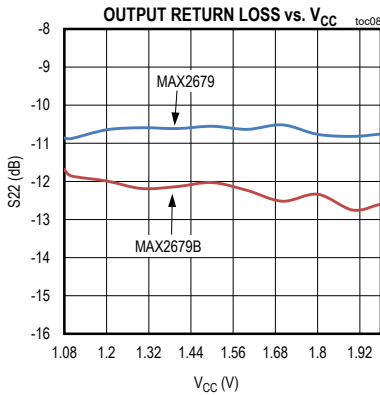
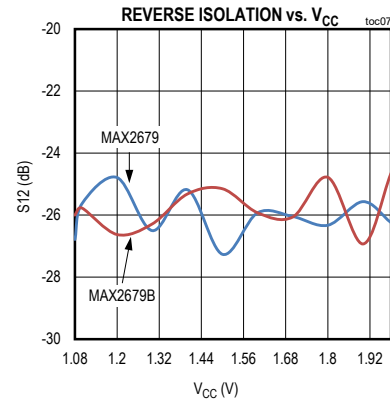
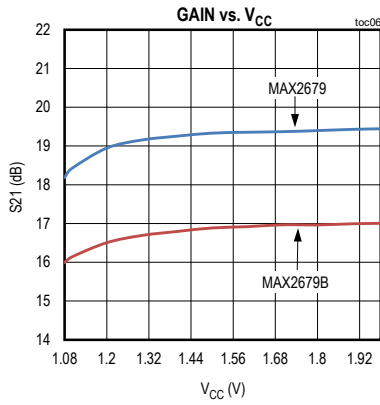
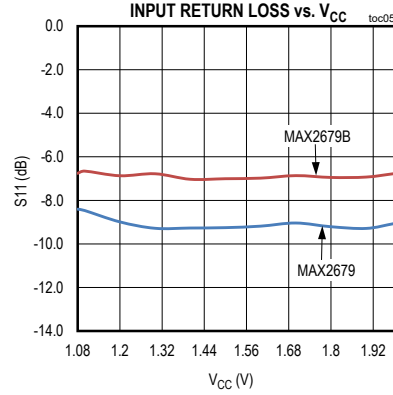
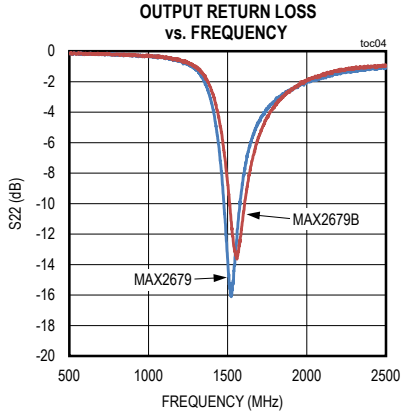

Typical Operating Characteristics (continued)

$V_{CC} = R_{FOUT}/SHDNB = 1.8V$  and  $T_A = +25^\circ C$ , at 1575.42MHz unless otherwise noted.

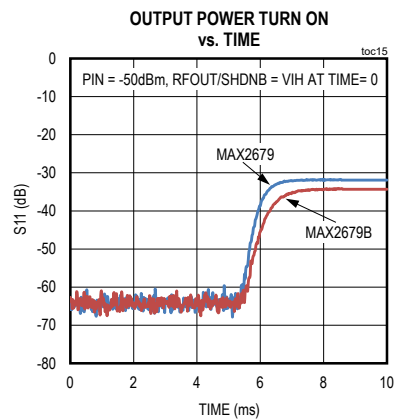
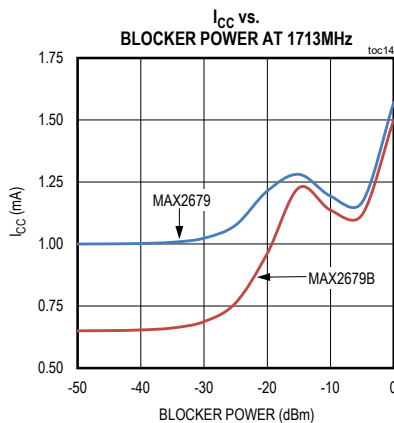
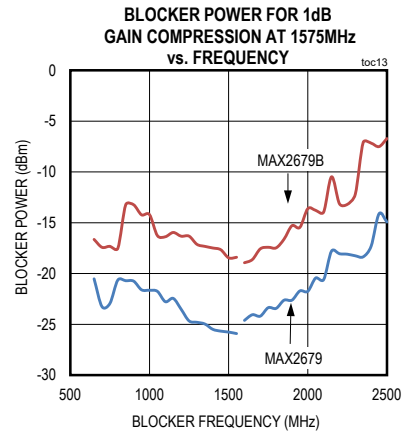
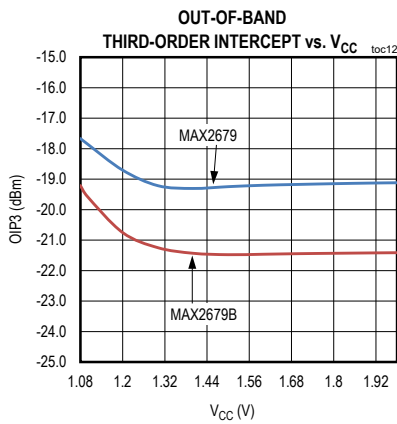
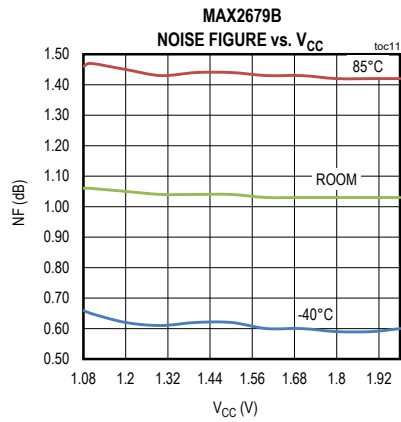
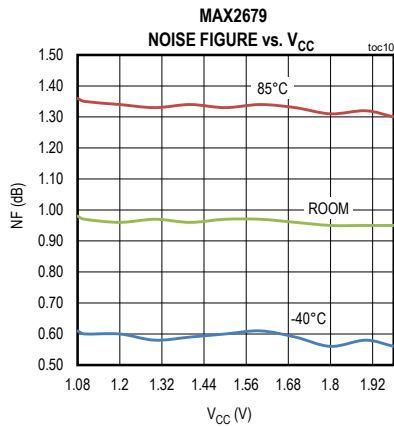

Pin Configuration

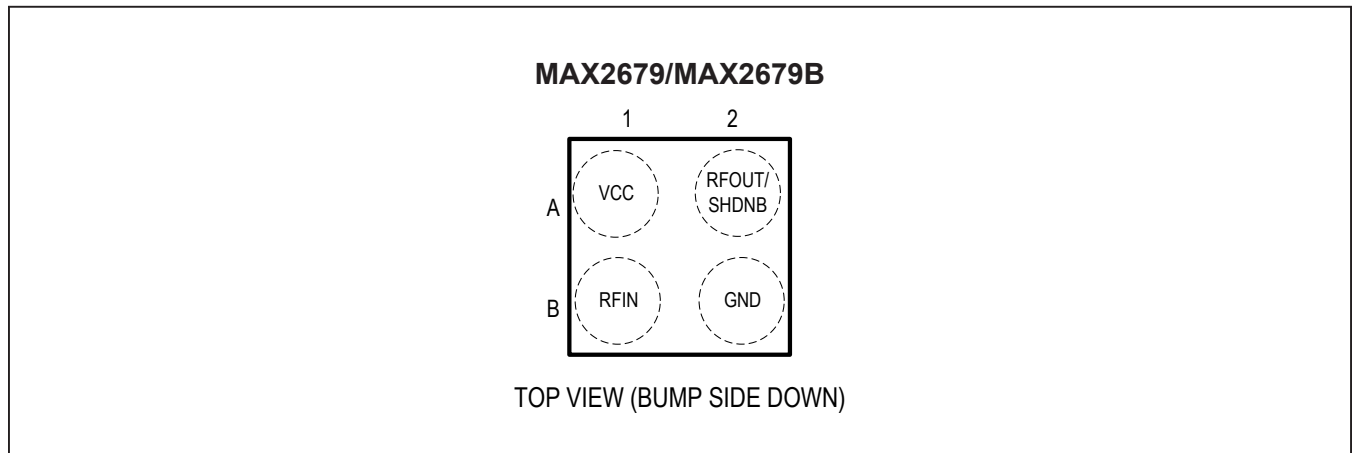

Pin Description

PIN	NAME	FUNCTION
MAX2679/ MAX2679B		
A1	V <sub>CC</sub>	Supply Voltage. Bypass to ground with a 1000pF capacitor as close as possible to the IC.
A2	RFOUT/ SHDNB	RF Output. RFOUT is internally matched to 50Ω. Applying logic-high through a 25kΩ resistor enables the IC. Applying logic-low through a 25kΩ resistor disables the IC.
B1	RFIN	RF Input. Requires a DC-blocking capacitor and external matching components.
B2	GND	Ground. Connect to the PCB ground plane.

Functional Diagram

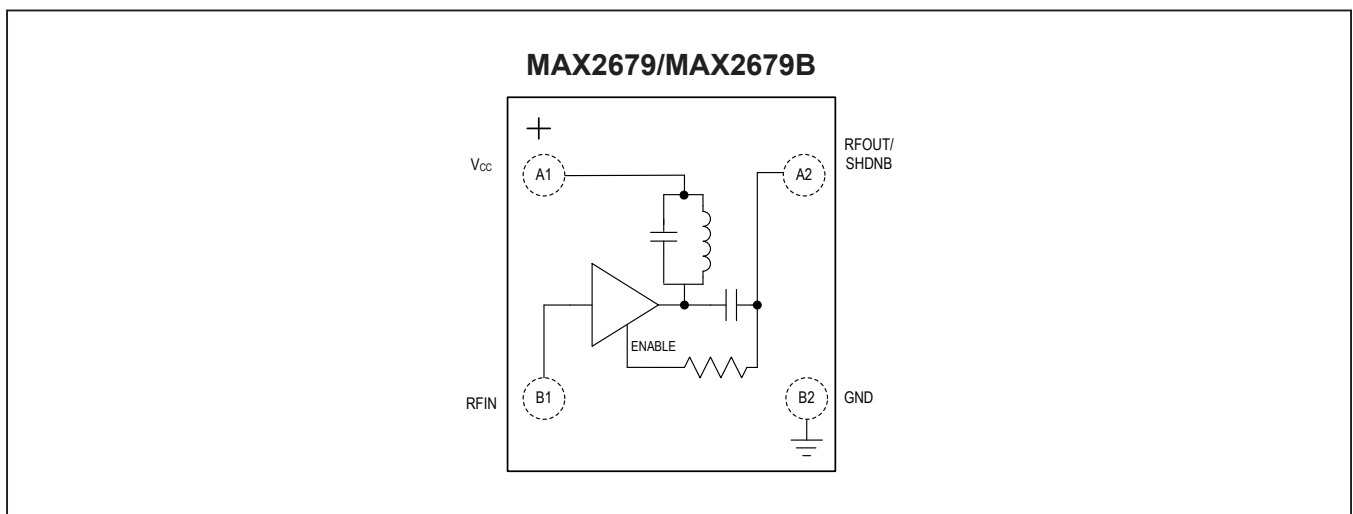

### Detailed Description

The MAX2679 and MAX2679B are LNAs designed for GPS L1, Galileo, and GLONASS applications. The devices feature an optional power-shutdown control mode to eliminate the need for an external supply switch. The device achieves high gain and low noise figure in an ultra-small package ideal for space-sensitive applications.

### Input and Output Matching

The devices require an off-chip input matching. Only an inductor in series with a DC-blocking capacitor is needed to form the input matching circuit. The [Typical Application Circuits](#) shows the recommended input-matching network. These values are optimized for the best simultaneous gain, noise figure, and return loss performance. The device integrates an on-chip matching to 50Ω at the output, eliminating the need for external matching components.

### Low-Power Shutdown Mode

The MAX2679 and MAX2679B include a shutdown feature to turn off the entire chip. Active mode is enabled by floating the RFOUT bump or by applying  $V_{IH}$  through

an external 25kΩ resistor. To enter low-power shutdown mode, apply  $V_{IL}$  to the RFOUT/SHDNB bump through an external 25kΩ resistor.

### Applications Information

#### Printed Circuit Board (PCB) Design

A properly designed PCB is essential to any RF microwave circuit. Use controlled-impedance lines on all high-frequency inputs and outputs. Bypass  $V_{CC}$  with decoupling capacitors located close to the device. For long  $V_{CC}$  lines, it may be necessary to add decoupling capacitors. Locate these additional capacitors further away from the device package. Proper grounding of the GND bump is essential. If the PCB uses a topside RF ground, connect it directly to the GND bump. For a board where the ground is not on the component layer, connect the GND bump to the board with multiple vias close to the package. For general layout guidelines, refer to [www.maximintegrated.com/app-notes/index.mvp/id/5100](http://www.maximintegrated.com/app-notes/index.mvp/id/5100).

Refer to the MAX2679 EV kit schematic, Gerber data, PADS layout file, and BOM information for best practices.

### Typical Application Circuits

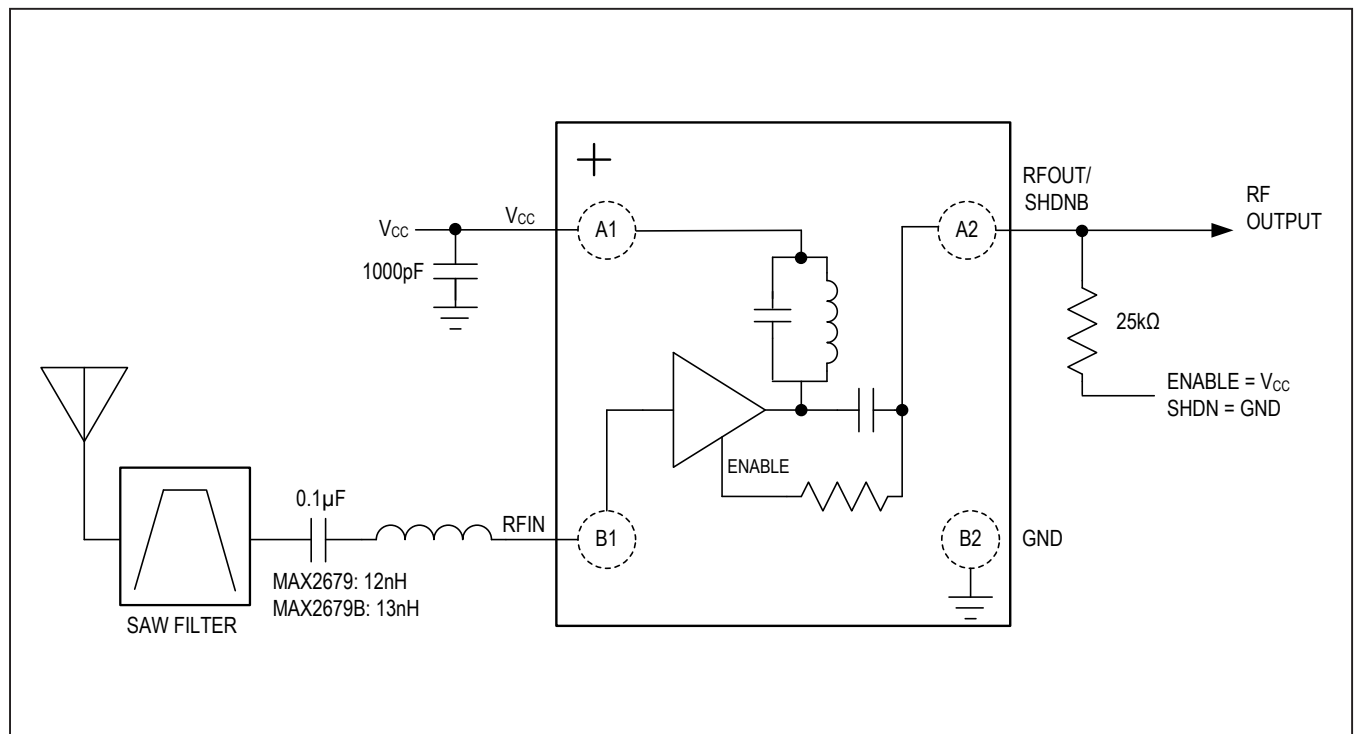

**L5 GPS/GNSS Band**

The MAX2679 can be tuned to the L5 GPS/GNSS band with additional components on the output. [Figures 1](#) and [Figure 2](#) show the values and position of the matching components. [Table 1](#) shows measured performance.

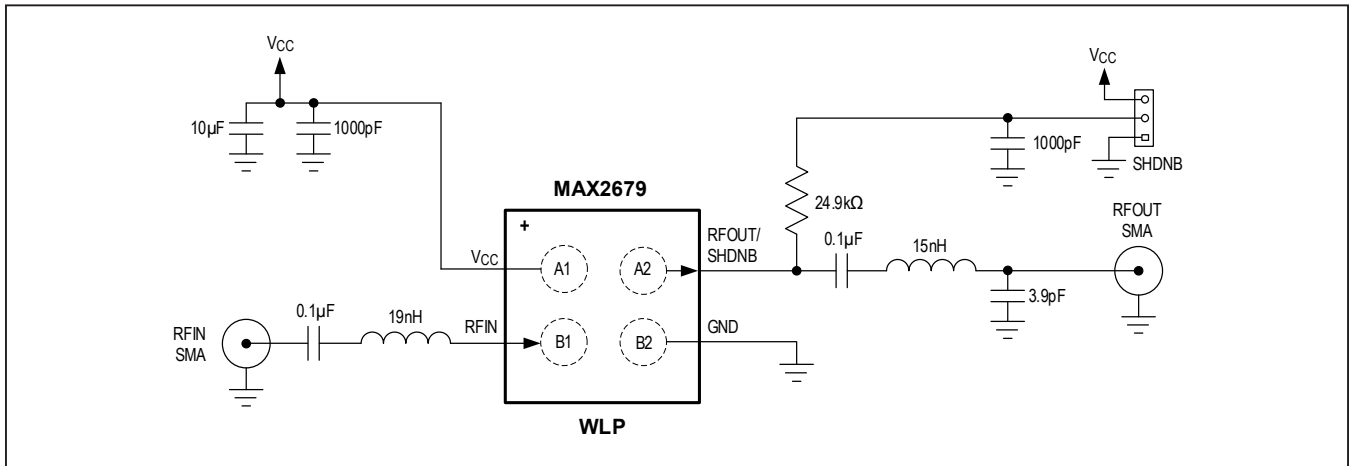

Figure 1. Application Diagram for L5 Band

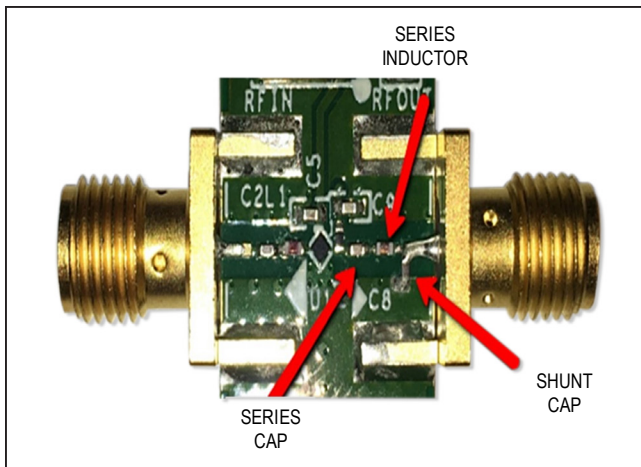

Figure 2. Component Placement on MAX2679 EV kit

**Table 1. L5 Band Measured Results**

L5 BAND (1176.45MHz)	
PARAMETER	VALUE (dB)
Noise Figure	1.18
Gain	19.2
Input Return Loss	7.1
Output Return Loss	27.1

**Ordering Information**

PART NUMBER	TEMP RANGE	PIN-PACKAGE	TOP MARKING
MAX2679ENS+	-40°C to +85°C	4 WLP	+1
MAX2679ENS+T	-40°C to +85°C	4 WLP	+1
MAX2679BENS+	-40°C to +85°C	4 WLP	+8
MAX2679BENS+T	-40°C to +85°C	4 WLP	+8

+Denotes a lead(Pb)-free/RoHS-compliant package.  
T Denotes tape-and-reel.



## Revision History

REVISION NUMBER	REVISION DATE	DESCRIPTION	PAGES CHANGED
0	3/17	Initial release	—
1	2/20	Added <i>L5 GPS/GNSS Band</i> section in <i>Applications Information</i>	8

For pricing, delivery, and ordering information, please contact Maxim Direct at 1-888-629-4642, or visit Maxim Integrated's website at [www.maximintegrated.com](http://www.maximintegrated.com).

*Maxim Integrated cannot assume responsibility for use of any circuitry other than circuitry entirely embodied in a Maxim Integrated product. No circuit patent licenses are implied. Maxim Integrated reserves the right to change the circuitry and specifications without notice at any time. The parametric values (min and max limits) shown in the Electrical Characteristics table are guaranteed. Other parametric values quoted in this data sheet are provided for guidance.*

## X-ON Electronics

Largest Supplier of Electrical and Electronic Components

*Click to view similar products for [RF Amplifier](#) category:*

*Click to view products by [Maxim](#) manufacturer:*

Other Similar products are found below :

[A82-1](#) [BGA622H6820XTSA1](#) [BGA 728L7 E6327](#) [BGB719N7ESDE6327XTMA1](#) [HMC397-SX](#) [HMC405](#) [HMC561-SX](#) [HMC8120-SX](#)  
[HMC8121-SX](#) [HMC-ALH382-SX](#) [HMC-ALH476-SX](#) [SE2433T-R](#) [SMA3101-TL-E](#) [SMA39](#) [A66-1](#) [A66-3](#) [A67-1](#) [LX5535LQ](#) [LX5540LL](#)  
[MAAM02350](#) [HMC3653LP3BETR](#) [HMC549MS8GETR](#) [HMC-ALH435-SX](#) [SMA101](#) [SMA32](#) [SMA411](#) [SMA531](#) [SST12LP17E-XX8E](#)  
[SST12LP19E-QX6E](#) [WPM0510A](#) [HMC5929LS6TR](#) [HMC5879LS7TR](#) [HMC1126](#) [HMC1087F10](#) [HMC1086](#) [HMC1016](#) [SMA1212](#)  
[MAX2689EWS+T](#) [MAAMSS0041TR](#) [MAAM37000-A1G](#) [LTC6430AIUF-15#PBF](#) [CHA5115-QDG](#) [SMA70-2](#) [SMA4011](#) [A231](#) [HMC-](#)  
[AUH232](#) [LX5511LQ](#) [LX5511LQ-TR](#) [HMC7441-SX](#) [HMC-ALH310](#)