

# MAX2692/MAX2695

## WLAN/WiMAX Low-Noise Amplifiers

### General Description

The MAX2692/MAX2695 low-noise amplifiers (LNAs) are designed for WLAN/WiMAX® applications. Designed in Maxim's advanced SiGe process, the devices achieve high gain and low noise figure while maximizing 3rd-order intercept point.

The devices operate from a +1.6V to +3.6V single supply. The optional shutdown feature in the devices reduces the supply current to less than 10µA. The devices are available in a very small, lead-free, RoHS-compliant, 0.86mm x 0.86mm wafer-level package (WLP).

### Applications

- Smart Phones
- Notebook PCs/Tablets
- Industrial WLAN/WiMAX
- Embedded Modules
- Automotive

### Features

- ◆ 2.5GHz WLAN (MAX2692)
- ◆ 3.7GHz WiMAX (MAX2695)
- ◆ High-Power Gain: 18dB (MAX2692)
- ◆ Low Noise Figure: 1.1dB (MAX2692)
- ◆ High-Input-IP3: -3dBm (MAX2695)
- ◆ Integrated 50Ω Output Matching Circuit
- ◆ Low Supply Current: 4.0mA
- ◆ Low Bill of Materials: One Inductor, Two Capacitors
- ◆ Small Footprint: 0.86mm x 0.86mm

*Ordering Information appears at end of data sheet.*

For related parts and recommended products to use with this part, refer to [www.maxim-ic.com/MAX2692.related](http://www.maxim-ic.com/MAX2692.related).

### Typical Operating Circuit

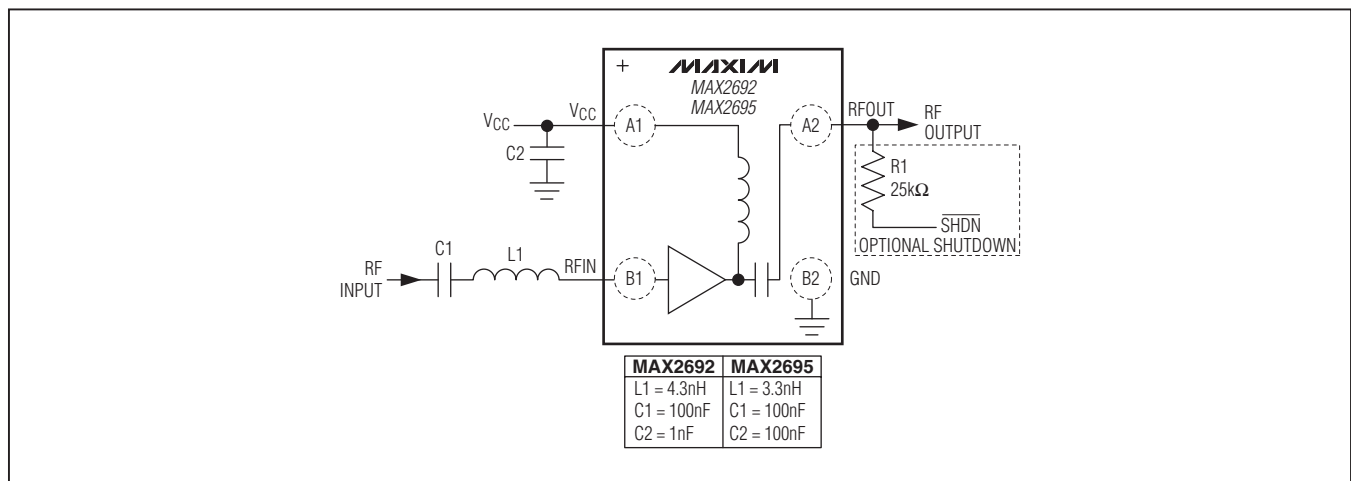

WiMAX is a registered service mark of WiMAX Forum.

# MAX2692/MAX2695

## WLAN/WiMAX Low-Noise Amplifiers

### ABSOLUTE MAXIMUM RATINGS

V <sub>CC</sub> to GND.....	-0.3V to +3.9V	Operating Temperature Range .....	-40°C to +85°C
RFOUT to GND.....	-0.3V to (operating V <sub>CC</sub> + 0.3V)	Junction Temperature .....	+150°C
Maximum RF Input Power .....	+5dBm	Storage Temperature Range.....	-65°C to +160°C
Continuous Power Dissipation (T <sub>A</sub> = +70°C)		Soldering Temperature (reflow) .....	+260°C
WLP (derates 9.7mW/°C above +70°C) .....	776mW		
Maximum Current into RF Input.....	10mA		

**Note 1:** Refer to Application Note 1891: *Wafer-Level Packaging (WLP) and its Applications*.

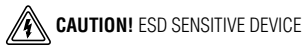

Stresses beyond those listed under "Absolute Maximum Ratings" may cause permanent damage to the device. These are stress ratings only, and functional operation of the device at these or any other conditions beyond those indicated in the operational sections of the specifications is not implied. Exposure to absolute maximum rating conditions for extended periods may affect device reliability.

### DC ELECTRICAL CHARACTERISTICS

(MAX2692/MAX2695 EV kit, V<sub>CC</sub> = 1.6V to 3.6V, T<sub>A</sub> = -40°C to +85°C, no RF signals are applied. Typical values are at V<sub>CC</sub> = 2.85V and T<sub>A</sub> = +25°C, unless otherwise noted.) (Note 2)

PARAMETER	CONDITIONS		MIN	TYP	MAX	UNITS
Supply Voltage			1.6	2.85	3.6	V
Supply Current	SHDN = high	MAX2692	4.0			mA
		MAX2695	4.0			
	Shutdown mode, V <sub>SHDN</sub> = 0V				10	µA
Digital Input Logic-High	(Note 3)		1.2			V
Digital Input Logic-Low	(Note 3)				0.45	V

### AC ELECTRICAL CHARACTERISTICS

(MAX2692/MAX2695 EV kit, V<sub>CC</sub> = 1.6V to 3.6V, T<sub>A</sub> = -40°C to +85°C, MAX2692 f<sub>RFIN</sub> = 2.45GHz, MAX2695 f<sub>RFIN</sub> = 3.5GHz. Typical values are at V<sub>CC</sub> = 2.85V and T<sub>A</sub> = +25°C, unless otherwise noted.) (Note 3)

PARAMETER	CONDITIONS		MIN	TYP	MAX	UNITS
RF Frequency	MAX2692 (WLAN)		2.45			GHz
	MAX2695 (WiMax)		3.5			
Power Gain	V <sub>CC</sub> = 2.85V (Note 4)	MAX2692	13.5	18.2		dB
		MAX2695	11.1	15.6		
	V <sub>CC</sub> = 1.6V	MAX2692	13.2	18		
		MAX2695	10.9	15.6		
Noise Figure	V <sub>CC</sub> = 1.6V to 3.6V	MAX2692	1.1			dB
		MAX2695	1.2			
3rd-Order Input Intercept Point	(Note 5)	MAX2692	-3			dBm
		MAX2695	-3			
Input 1dB Compression Point	(Note 6)	MAX2692	-16			dBm
		MAX2695	14.5			
Input Return Loss	MAX2692		8.5			dBm
	MAX2695		7.5			

# MAX2692/MAX2695

## WLAN/WiMAX Low-Noise Amplifiers

### AC ELECTRICAL CHARACTERISTICS (continued)

(MAX2692/MAX2695 EV kit,  $V_{CC} = 1.6V$  to  $3.6V$ ,  $T_A = -40^{\circ}C$  to  $+85^{\circ}C$ , MAX2692  $f_{RFIN} = 2.45GHz$ , MAX2695  $f_{RFIN} = 3.5GHz$ . Typical values are at  $V_{CC} = 2.85V$  and  $T_A = +25^{\circ}C$ , unless otherwise noted.) (Note 2)

PARAMETER	CONDITIONS	MIN	TYP	MAX	UNITS
Output Return Loss	MAX2692		17		dB
	MAX2695		14		
Reverse Isolation	MAX2692		32		dB
	MAX2695		28		

**Note 2:** Min and max limits guaranteed by test at  $T_A = +25^{\circ}C$  and guaranteed by design and characterization at  $T_A = -40^{\circ}C$  and  $T_A = +85^{\circ}C$ , unless otherwise noted.

**Note 3:** Min and max limits guaranteed by test at  $T_A = +25^{\circ}C$ .

**Note 4:** Min limit guaranteed by design and characterization.

**Note 5:** Measured with the two tones located at 1MHz and 2MHz offset from the center of the band with -30dBm/tone.

**Note 6:** Measured with a tone located at 2.45GHz for the MAX2692 and 3.5GHz for the MAX2695.

### Typical Operating Characteristics

(MAX2692/MAX2695 EV kit. Typical values are at  $V_{CC} = 2.85V$ ,  $T_A = +25^{\circ}C$ , unless otherwise noted.)

#### MAX2692

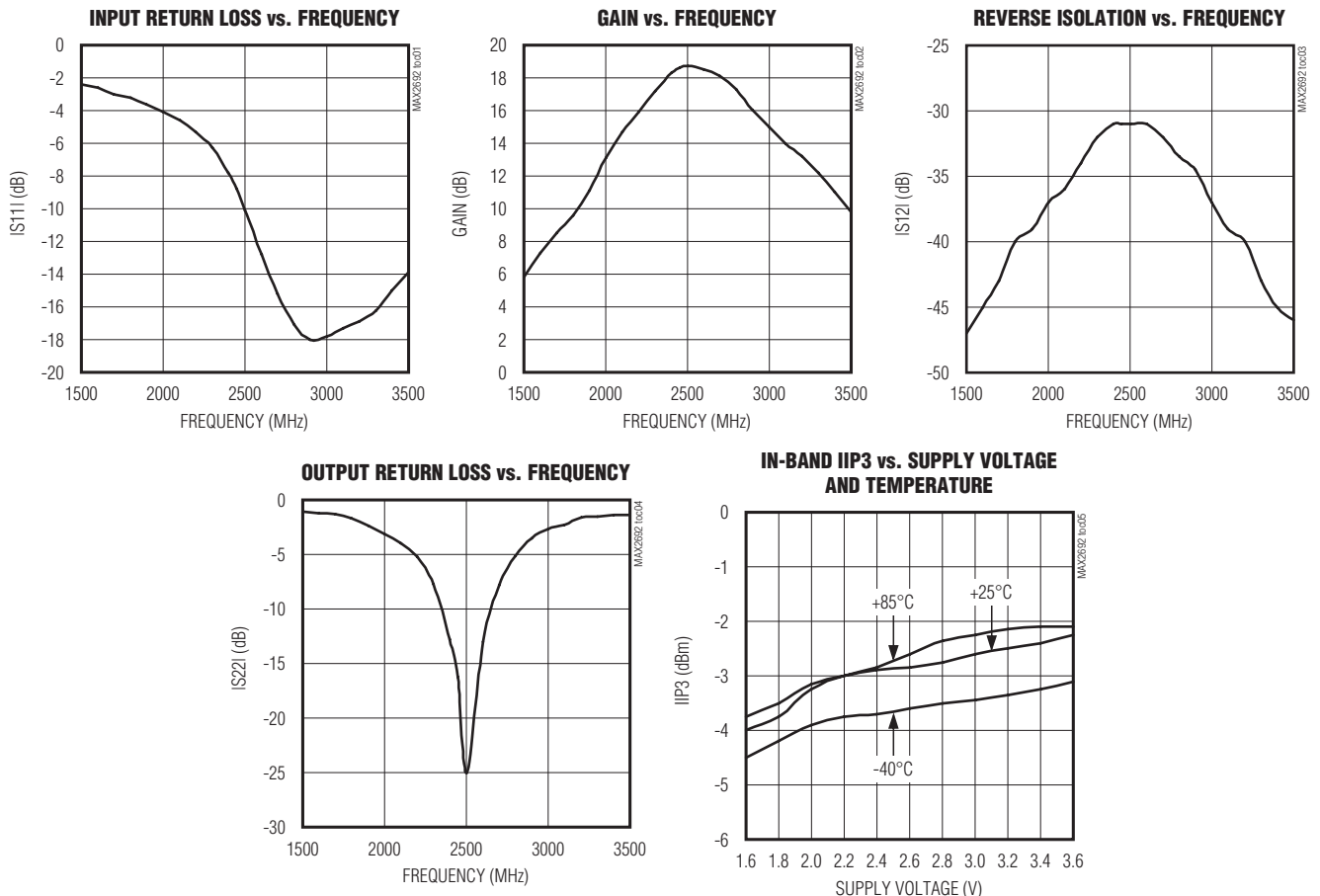

# MAX2692/MAX2695

## WLAN/WiMAX Low-Noise Amplifiers

### Typical Operating Characteristics (continued)

(MAX2692/MAX2695 EV kit. Typical values are at  $V_{CC} = 2.85V$ ,  $T_A = +25^\circ C$ , unless otherwise noted.)

#### MAX2692

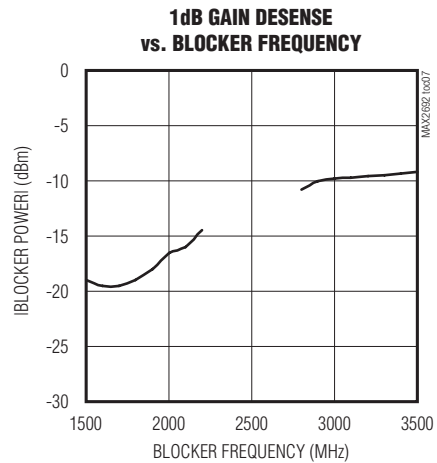
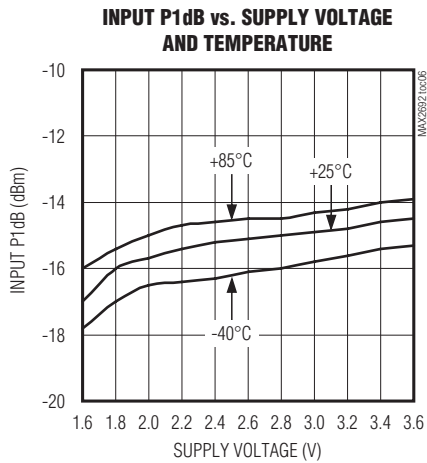

#### MAX2695

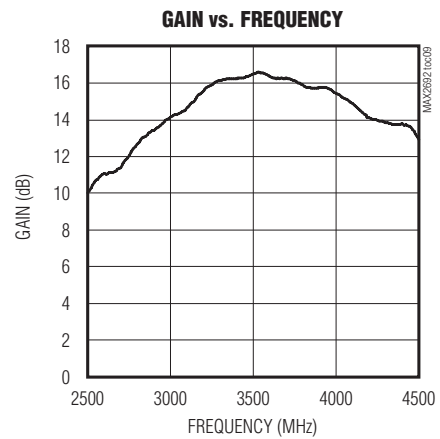
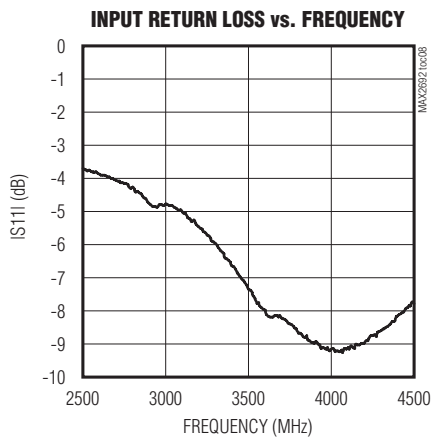

# MAX2692/MAX2695

## WLAN/WiMAX Low-Noise Amplifiers

### Typical Operating Characteristics (continued)

(MAX2692/MAX2695 EV kit. Typical values are at  $V_{CC} = 2.85V$ ,  $T_A = +25^\circ C$ , unless otherwise noted.)

#### MAX2695

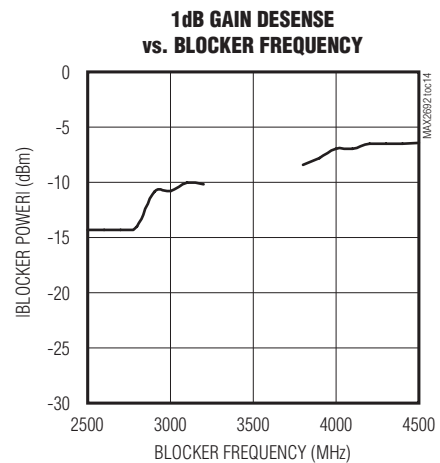
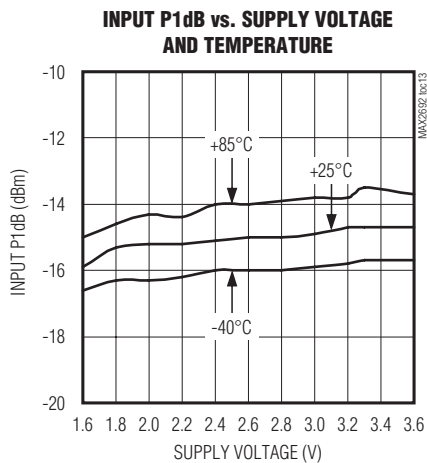
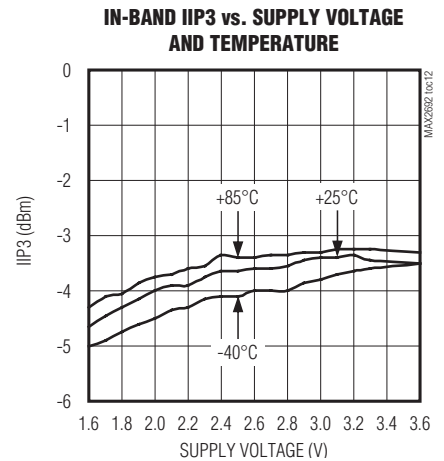
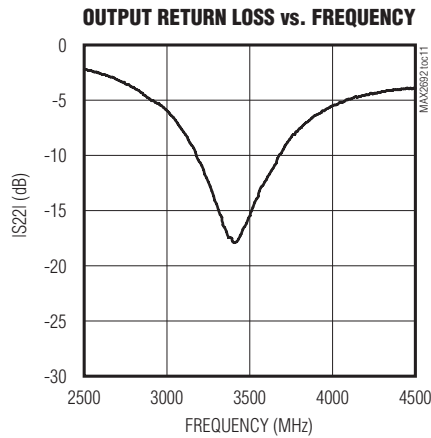
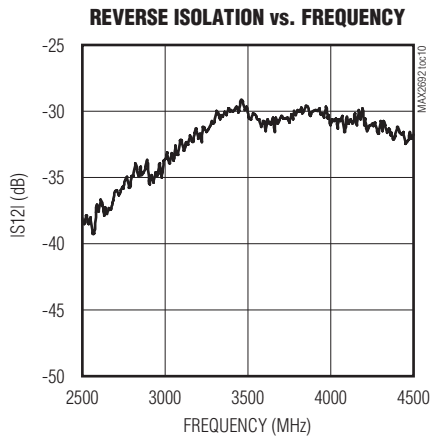

# MAX2692/MAX2695

## WLAN/WiMAX Low-Noise Amplifiers

### Bump Configuration

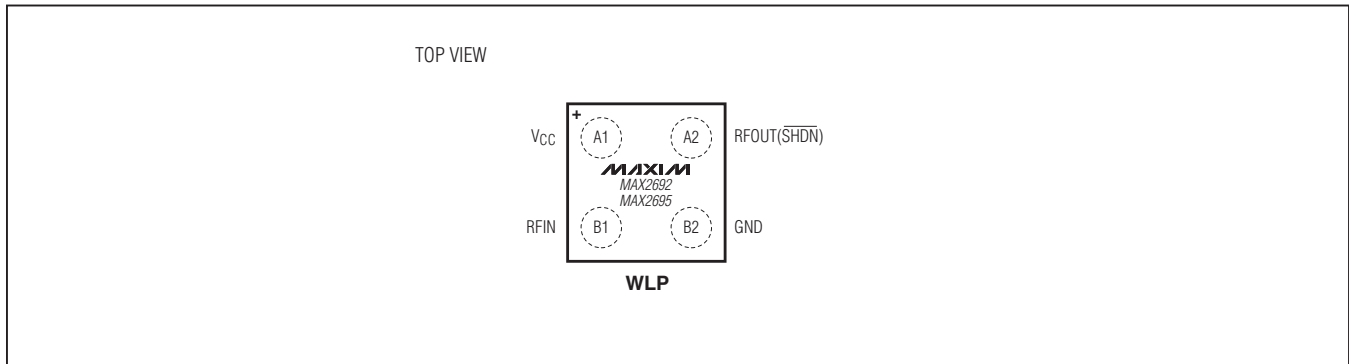

### Bump Description

BUMP	NAME	FUNCTION
A1	V <sub>CC</sub>	Supply Voltage. Bypass to ground with a 10pF capacitor as close as possible to the IC.
A2	RFOUT (SHDN)	RF Output/ $\overline{\text{SHDN}}$ Input. RFOUT is internally matched to 50 $\Omega$ and pulled up to V <sub>CC</sub> through a 25k $\Omega$ resistor. $\overline{\text{SHDN}}$ is shared with the RFOUT bump. The devices are in active mode by default once V <sub>CC</sub> is applied. RFOUT( $\overline{\text{SHDN}}$ ) can be pulled to a DC low externally to shut down the IC.
B1	RFIN	RF Input. Requires a DC-blocking capacitor and external matching components.
B2	GND	Ground. Connect to the PCB ground plane.

### Detailed Description

The MAX2692/MAX2695 are LNAs designed for WLAN/WiMax applications. The devices feature an optional power-shutdown control mode to eliminate the need for an external supply switch. The devices achieve high gain, low noise figure, and excellent linearity.

#### Input and Output Matching

The devices require an off-chip input matching. Only an inductor in series with a DC-blocking capacitor is needed to form the input matching circuit. The [Typical Operating Circuit](#) shows the recommended input-matching network. These values are optimized for the best simultaneous gain, noise figure, and return loss performance. The

devices integrate an on-chip output matching to 50 $\Omega$  at the output, eliminating the need for external matching components. [Table 1](#) and [Table 2](#) list typical device S parameters and K<sub>f</sub> values. Typical noise parameters are shown in [Table 3](#) and [Table 4](#).

#### Shutdown

The devices include an optional shutdown feature to turn off the entire chip. The devices are placed in active mode by default once V<sub>CC</sub> is applied, due to the on-chip pull-up resistor to V<sub>CC</sub> at the RFOUT bump (shared with the  $\overline{\text{SHDN}}$  input). To shut down the part, apply a logic-low to the RFOUT bump through an external resistor with an adequate value, e.g., 25k $\Omega$ , in order not to load the RF output signal during active operation.

## WLAN/WiMAX Low-Noise Amplifiers

**Table 1. MAX2692 Typical S Parameter Values and K-Factor**

FREQ. (MHz)	S11 MAG (dB)	S11 PHASE (DEGREES)	S21 MAG (dB)	S21 PHASE (DEGREES)	S12 MAG (dB)	S12 PHASE (DEGREES)	S22 MAG (dB)	S22 PHASE (DEGREES)	K <sub>f</sub>
2000	-1.9	-160.0	9.8	94.6	-41.1	107.6	-2.6	68.0	2.7
2100	-2.0	-168.2	10.8	79.9	-39.5	99.8	-3.1	47.2	2.2
2200	-2.1	-177.4	10.9	74.5	-39.7	73.5	-4.2	20.6	3.0
2300	-2.5	175.1	13.7	62.0	-35.6	57.1	-6.3	3.7	2.0
2400	-2.8	167.6	15.1	40.3	-35.5	37.7	-7.7	-24.3	2.0
2500	-3.2	159.6	15.9	20.5	-34.4	15.1	-10.1	-65.9	1.9
2600	-3.6	153.0	16.1	-1.4	-32.8	-5.3	-12.0	-130.0	1.7
2700	-4.1	147.8	16.0	-24.2	-34.4	-31.7	-9.8	164.6	2.1
2800	-4.3	144.0	15.6	-45.1	-34.2	-57.8	-6.8	120.6	1.9
2900	-4.4	140.2	14.7	-60.7	-36.2	-72.0	-4.7	89.4	2.2
3000	-4.3	135.0	13.4	-77.1	-37.3	-83.2	-3.4	65.0	2.3

**Table 2. MAX2695 Typical S Parameter Values and K-Factor**

FREQ. (MHz)	S11 MAG (dB)	S11 PHASE (DEGREES)	S21 MAG (dB)	S21 PHASE (DEGREES)	S12 MAG (dB)	S12 PHASE (DEGREES)	S22 MAG (dB)	S22 PHASE (DEGREES)	K <sub>f</sub>
3000	-1.9	119.7	11.5	14.2	-35.9	42.9	-5.4	-26.8	1.7
3100	-1.9	112.1	12.1	0.4	-34.6	32.1	-6.9	-46.6	1.6
3200	-1.9	104.5	12.7	-15.1	-34.1	21.7	-8.9	-68.3	1.6
3300	-2.1	97.1	13.2	-29.2	-34.2	1.5	-11.7	-95.9	1.8
3400	-2.2	90.0	13.4	-42.8	-32.7	-2.8	-15.0	-135.5	1.7
3500	-2.4	83.1	13.5	-57.2	-32.4	-23.2	-16.2	166.3	1.8
3600	-2.6	77.0	13.5	-72.2	-33.2	-37.1	-13.7	116.2	2.1
3700	-2.6	70.7	13.7	-84.6	-31.9	-41.3	-11.1	86.1	1.7
3800	-2.8	64.0	13.5	-96.0	-32.1	-57.3	-8.8	62.7	1.8
3900	-3.0	58.4	13.4	-112.5	-32.7	-68.4	-7.1	42.1	1.8
4000	-3.2	52.7	13.7	-123.5	-31.0	-80.0	-6.0	23.8	1.4

**Table 3. MAX2692 Typical Noise Parameters (V<sub>CC</sub> = 2.85V, T<sub>A</sub> = +25°C)**

FREQUENCY (MHz)	F <sub>MIN</sub> (dB)	Γ <sub>OPT</sub>	Γ <sub>OPT</sub>   ANGLE	R <sub>N</sub> (Ω)
2300	0.84	0.49	44	12.0
2350	0.84	0.48	45	11.9
2400	0.85	0.48	46	11.8
2450	0.85	0.48	47	11.8
2500	0.86	0.48	48	11.7
2550	0.87	0.47	49	11.7
2600	0.87	0.47	50	11.7

# MAX2692/MAX2695

## WLAN/WiMAX Low-Noise Amplifiers

Table 4. MAX2695 Typical Noise Parameters ( $V_{CC} = 2.85V$ ,  $T_A = +25^\circ C$ )

FREQUENCY (MHz)	FMIN (dB)	$ \Gamma_{OPT} $	$ \Gamma_{OPT} $ ANGLE	$R_N$ ( $\Omega$ )
3400	1.02	0.44	65	11.3
3450	1.03	0.44	66	11.2
3500	1.03	0.44	67	11.2
3550	1.04	0.44	68	11.1
3600	1.04	0.44	69	11.1
3650	1.05	0.43	69	11.0
3700	1.06	0.43	70	10.9

### Applications Information

A properly designed PCB is essential to any RF microwave circuit. Use controlled-impedance lines on all high-frequency inputs and outputs. Bypass  $V_{CC}$  with decoupling capacitors located close to the device. For long  $V_{CC}$  lines, it may be necessary to add decoupling capacitors. Locate these additional capacitors further away from the device package. Proper grounding of the GND bump is essential. If the PCB uses a topside RF ground, connect it directly to the GND bump. For a board where the ground is not on the component layer, connect the GND bump to the board with multiple vias close to the package.

Refer to [www.maxim-ic.com/datasheet/index.mvp/id/6939/t/do](http://www.maxim-ic.com/datasheet/index.mvp/id/6939/t/do) for the MAX2692/MAX2695 EV kit schematic, Gerber data, PADS layout file, and BOM information.

### Chip Information

PROCESS: SiGe BiCMOS

### Ordering Information

PART	TEMP RANGE	PIN-PACKAGE
MAX2692EWS+T	-40°C to +85°C	4 WLP
MAX2695EWS+T	-40°C to +85°C	4 WLP

+Denotes a lead(Pb)-free/RoHS-compliant package.

T = Tape and reel.

### Package Information

For the latest package outline information and land patterns (footprints), go to [www.maxim-ic.com/packages](http://www.maxim-ic.com/packages). Note that a "+", "#", or "-" in the package code indicates RoHS status only. Package drawings may show a different suffix character, but the drawing pertains to the package regardless of RoHS status.

PACKAGE TYPE	PACKAGE CODE	OUTLINE NO.	LAND PATTERN NO.
4 WLP	W40A0+1	<a href="#">21-0480</a>	Refer to <a href="#">Application Note 1891</a>



# MAX2692/MAX2695

## WLAN/WiMAX Low-Noise Amplifiers

### Revision History

REVISION NUMBER	REVISION DATE	DESCRIPTION	PAGES CHANGED
0	9/11	Initial release	—

Maxim cannot assume responsibility for use of any circuitry other than circuitry entirely embodied in a Maxim product. No circuit patent licenses are implied. Maxim reserves the right to change the circuitry and specifications without notice at any time. The parametric values (min and max limits) shown in the Electrical Characteristics table are guaranteed. Other parametric values quoted in this data sheet are provided for guidance.

**Maxim Integrated Products, 120 San Gabriel Drive, Sunnyvale, CA 94086 408-737-7600** \_\_\_\_\_ **9**

**MAX2692/MAX2695**

**WLAN/WiMAX Low-Noise Amplifiers**

## X-ON Electronics

Largest Supplier of Electrical and Electronic Components

*Click to view similar products for [RF Development Tools](#) category:*

*Click to view products by [Maxim](#) manufacturer:*

Other Similar products are found below :

[MAAM-011117](#) [MAAP-015036-DIEEV2](#) [EV1HMC1113LP5](#) [EV1HMC6146BLC5A](#) [EV1HMC637ALP5](#) [122410-HMC686LP4E](#) [ADL5363-EVALZ](#) [130437-HMC1010LP4E](#) [EKIT01-HMC1197LP7F](#) [SKYA21001-EVB](#) [SMP1331-085-EVB](#) [EVAL01-HMC1041LC4](#) [MAAL-011111-000SMB](#) [MAAM-009633-001SMB](#) [107712-HMC369LP3](#) [107780-HMC322ALP4](#) [SP000416870](#) [EV1HMC520ALC4](#) [EV1HMC244AG16](#) [EV1HMC539ALP3](#) [124694-HMC742ALP5](#) [SC20ASATEA-8GB-STD](#) [MAX2692EVKIT#](#) [SKY12343-364LF-EVB](#) [108703-HMC452QS16G](#) [119197-HMC658LP2](#) [EV1HMC647ALP6](#) [ADL5725-EVALZ](#) [106815-HMC441LM1](#) [UXN14M9PE](#) [SIMSA868-DKL](#) [SIMSA868C-DKL](#) [SKY65806-636EK1](#) [SKY68020-11EK1](#) [SKY67159-396EK1](#) [SKY66181-11-EK1](#) [SKY65804-696EK1](#) [SKY13396-397LF-EVB](#) [SKY13380-350LF-EVB](#) [SKY13322-375LF-EVB](#) [SKY12207-478LF-EVB](#) [SE5023L-EK1](#) [SE5004L-EK1](#) [SE2436L-EK1](#) [Se2435L-EK1](#) [SIMSA915C-DKL](#) [SIMSA915-DKL](#) [SIMSA433C-DKL](#) [SKY12211-478LF-EVB](#) [EVK-R202-00B](#)