



High CMRR RS-485 Transceiver with ±60V Isolation

MAX3158

General Description

The MAX3158 is a high CMRR RS-485/RS-422 data-communications interface providing ±60V isolation in a hybrid microcircuit. A single +5V supply on the logic side powers both sides of the interface, with external 100V capacitors transferring power from the logic side to the isolated side. Each MAX3158 contains one transmitter and one receiver and is guaranteed to operate at data rates up to 250kbps. Drivers are short-circuit current limited and protected against excessive power dissipation by thermal shutdown circuitry that places the driver outputs into a high-impedance state. The receiver input has a fail-safe feature that guarantees a logic-high receiver output if the inputs are open, shorted, or connected to a terminated transmission line with all drivers disabled.

The MAX3158 typically draws 25mA of supply current when unloaded or when fully loaded with the driver disabled. Supply current drops to 25µA when the device is placed in shutdown mode. The device is pin selectable between half- and full-duplex mode and also features an independently programmable receiver and transmitter output phase through separate pins. The MAX3158 is a low-cost replacement for opto-isolated transceivers. For fully isolated RS-485/RS-422 transceivers, refer to the MAX1480 family data sheet.

Applications

Industrial Controls	Telecommunications
Level Translators	Local Area Networks

Features

- ◆ ±60V Isolated Data Interface
- ◆ +5V Single Supply
- ◆ Low-Cost Replacement for Opto-Isolated Transceivers
- ◆ True Fail-Safe Receiver While Maintaining EIA/TIA-485 Compliance
- ◆ Pin-Selectable Full/Half-Duplex Operation
- ◆ Phase Controls to Correct for Twisted-Pair Reversal
- ◆ 25µA Low-Power Shutdown Mode
- ◆ Thermal Shutdown for Driver Overload Protection
- ◆ 28-Pin SSOP Package
- ◆ Slew-Rate-Limited Reduced EMI

Ordering Information

PART	TEMP RANGE	PIN-PACKAGE
MAX3158CAI	0°C to +70°C	28 SSOP
MAX3158CPI	0°C to +70°C	28 PDIP
MAX3158EAI	-40°C to +85°C	28 SSOP
MAX3158EPI	-40°C to +85°C	28 PDIP

Pin Configurations appear at end of data sheet.

Typical Operating Circuit

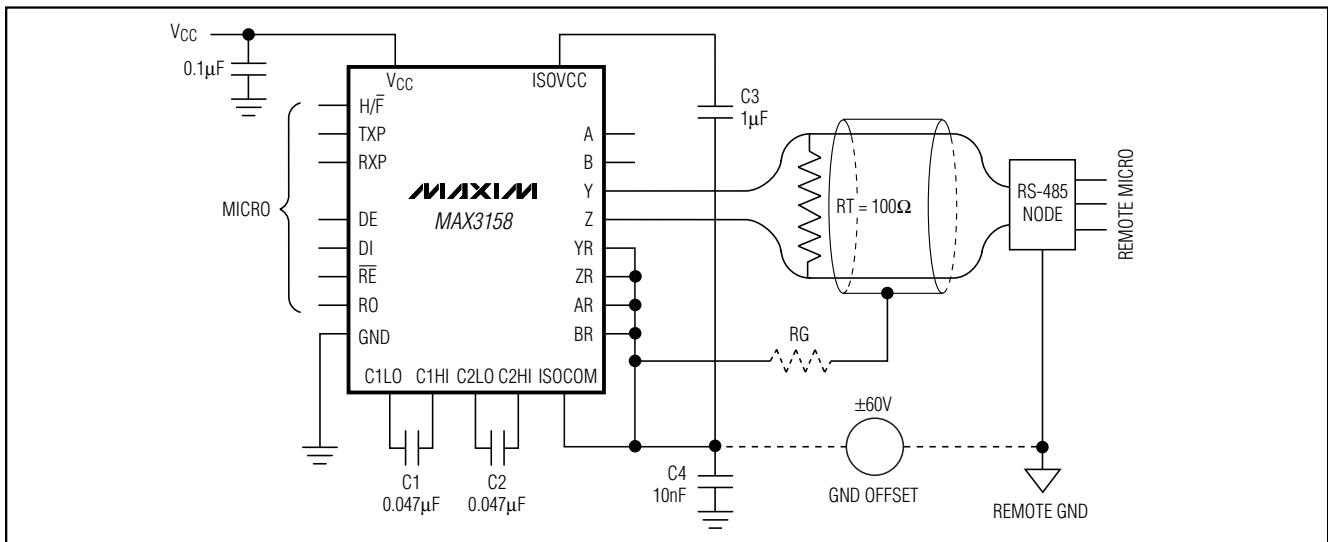

High CMRR RS-485 Transceiver with $\pm 60V$ Isolation

ABSOLUTE MAXIMUM RATINGS

(All voltages referenced to GND, unless otherwise noted.)

Supply Voltage (V_{CC}).....	+7V	Charge-Pump Capacitance Low (C1LO, C2LO)	-0.3V to ($V_{CC} + 0.3V$)
Cable Ground (ISOCOM)	$\pm 75V$	Charge-Pump Capacitance High (C1HI, C2HI) Relative to Cable Ground (ISOCOM)	-0.3V to ($ISOVCC + 0.3V$)
Isolated Supply ISOVCC Relative to Cable Ground (ISOCOM)	+7V	Continuous Power Dissipation ($T_A = +70^\circ C$)	
Digital Input, Output Voltage (DI, DE, \overline{RE} , TXP, RXP, RO).....	-0.3V to ($V_{CC} + 0.3V$)	28-Pin SSOP (derate 10.8mW/ $^\circ C$ above $+70^\circ C$)	860mW
Digital Inputs (H/ \overline{F}) Relative to Cable Ground (ISOCOM)	-0.3V to ($ISOVCC + 0.3V$)	28-Pin PDIP (derate 14.3mW/ $^\circ C$ above $+70^\circ C$).....	1143mW
Driver Output Voltage (Y, Z) Relative to Cable Ground (ISOCOM).....	-8V to +12.5V	Operating Temperature Ranges	
Receiver Input Voltage (A, B) Relative to Cable Ground (ISOCOM).....	-8V to +12.5V	MAX3158C_I	0 $^\circ C$ to +70 $^\circ C$
Termination Connections (YR, ZR, AR, BR) Relative to Cable Ground (ISOCOM).....	-8V to +12.5V	MAX3158E_I	-40 $^\circ C$ to +85 $^\circ C$
		Junction Temperature	+150 $^\circ C$
		Storage Temperature Range	-65 $^\circ C$ to +160 $^\circ C$
		Lead Temperature (soldering, 10s)	+300 $^\circ C$

Stresses beyond those listed under "Absolute Maximum Ratings" may cause permanent damage to the device. These are stress ratings only, and functional operation of the device at these or any other conditions beyond those indicated in the operational sections of the specifications is not implied. Exposure to absolute maximum rating conditions for extended periods may affect device reliability.

ELECTRICAL CHARACTERISTICS

($V_{CC} = +5V \pm 5\%$, YR = ZR = AR = BR = ISOCOM, C1 = C2 = 0.047 μF , C3 = C4 = 1 μF , $T_A = T_{MIN}$ to T_{MAX} , unless otherwise noted. Typical values are at $V_{CC} = +5V$ and $T_A = +25^\circ C$.) (Note 1)

PARAMETER	SYMBOL	CONDITIONS	MIN	TYP	MAX	UNITS
DRIVER						
Differential Driver Output, No Load	V_{OD1}	Figure 1, R = 10M Ω			6	V
Differential Driver Output, Loaded	V_{OD2}	Figure 1, R = 50 Ω (RS-422)	2.0			V
		Figure 1, R = 27 Ω (RS-485)	1.5			
Change in Magnitude of Differential Output Voltage (Note 2)	ΔV_{OD}	Figure 1, R = 50 Ω or R = 27 Ω			0.2	V
Driver Common-Mode Voltage	V_{OC}	Figure 1, R = 50 Ω or R = 27 Ω , V_{OC} relative to ISOCOM			3.5	V
Change in Magnitude of Common-Mode Voltage (Note 2)	ΔV_{OC}	Figure 1, R = 50 Ω or R = 27 Ω			0.2	V
Input High Voltage	V_{IH}	DE, DI, \overline{RE} , TXP, RXP, relative to GND, H/ \overline{F} relative to ISOCOM	2.0			V
Input Low Voltage	V_{IL}	DE, DI, \overline{RE} , TXP, RXP, relative to GND, H/ \overline{F} relative to ISOCOM			0.8	V
DI Input Hysteresis	V_{HYS}			100		mV

High CMRR RS-485 Transceiver with $\pm 60V$ Isolation

MAX3158

ELECTRICAL CHARACTERISTICS (continued)

($V_{CC} = +5V \pm 5\%$, $YR = ZR = AR = BR = ISOCOM$, $C1 = C2 = 0.047\mu F$, $C3 = C4 = 1\mu F$, $T_A = T_{MIN}$ to T_{MAX} , unless otherwise noted. Typical values are at $V_{CC} = +5V$ and $T_A = +25^\circ C$.) (Note 1)

PARAMETER	SYMBOL	CONDITIONS	MIN	TYP	MAX	UNITS
Input Current	I_{IN1}	DE, DI, \overline{RE}			± 2	μA
	I_{IN2}	H/ \overline{F} , TXP, RXP internal pulldown	10		40	
Input Current (A and B)	I_{IN3}	DE = GND, $V_{CC} = GND$ or 5.25V, $-7V \leq (V_{IN} - V_{ISOCOM}) \leq +12V$, AR = BR = ISOCOM	-5.0		+8.0	mA
		DE = GND, $V_{CC} = GND$ or 5.25V, $-7V \leq (V_{IN} - V_{ISOCOM}) \leq +12V$, AR open, BR open	-0.58		+1.0	
Output Leakage (Y and Z) Full Duplex	I_O	DE = GND, $V_{CC} = GND$ or 5.25V, $-7V \leq (V_{IN} - V_{ISOCOM}) \leq +12V$, YR = ZR = ISOCOM	-5.0		+8.0	mA
		DE = GND, $V_{CC} = GND$ or 5.25V, $-7V \leq (V_{IN} - V_{ISOCOM}) \leq +12V$, YR open, ZR open	-0.58		+1.0	
Driver Short-Circuit Output Current (Note 3)	IOSD1	$V_{ISOCOM} - 7V \leq V_{OUT} \leq V_{ISOVCC}$	-250			mA
	IOSD2	$V_{ISOCOM} - 7V \leq V_{OUT} \leq V_{ISOCOM} + 12V$			250	
RECEIVER						
Receiver Differential Threshold Voltage	V_{TH}	$-7V \leq V_{CM} - V_{ISOCOM} \leq +12V$	-200	-125	-50	mV
Receiver Input Hysteresis	ΔV_{TH}			25		mV
Receiver Output High Voltage	V_{OH}	$I_O = -4mA$, $V_{ID} = -50mV$	$V_{CC} - 1.5$			V
Receiver Output Low Voltage	V_{OL}	$I_O = 4mA$, $V_{ID} = -200mV$			0.4	V
Three-State Output Current at Receiver	I_{OZR}	$0.4V \leq V_O \leq 2.4V$			± 1	μA
Receiver Input Resistance	R_{IN}	$-7V \leq V_{CM} - V_{ISOCOM} \leq +12V$, AR = BR = ISOCOM	1.5			k Ω
		$-7V \leq V_{CM} - V_{ISOCOM} \leq +12V$, AR open, BR open	12			
Receiver Output Short-Circuit Current	I_{OSR}	$0V \leq V_{RO} \leq V_{CC}$	± 7		± 100	mA
SUPPLY CURRENT						
Supply Current	I_{CC}	No load, $\overline{RE} = DE = DI = GND$ or V_{CC}		25	85	mA
Supply Current in Shutdown Mode	I_{SHDN}	DE = GND, $\overline{RE} = V_{CC}$, $V_{ISOCOM} = GND$		25	60	μA
		DE = GND, $\overline{RE} = V_{CC}$, $V_{ISOCOM} = \pm 60V$			± 650	
Maximum Ground Differential	ΔV_{GND}	DE = GND, $\overline{RE} = V_{CC}$, I ISOCOM leakage I $\leq 650\mu A$	± 60			V

High CMRR RS-485 Transceiver with $\pm 60V$ Isolation

SWITCHING CHARACTERISTICS

($V_{CC} = +5V \pm 5\%$, $YR = ZR = AR = BR = ISOCOM$, $C1 = C2 = 0.047\mu F$, $C3 = C4 = 1\mu F$. Typical values are at $V_{CC} = +5V$ and $T_A = +25^\circ C$.)

PARAMETER	SYMBOL	CONDITIONS	MIN	TYP	MAX	UNITS
Driver Input to Output	t_{DPLH}	Figures 3 and 5, $R_{DIFF} = 54\Omega$, $C_{L1} = C_{L2} = 100pF$	400	1400	2000	ns
	t_{DPHL}	Figures 3 and 5, $R_{DIFF} = 54\Omega$, $C_{L1} = C_{L2} = 100pF$	400	1400	2000	
Driver Output Skew $t_{DPLH} - t_{DPHL}$	t_{DSKEW}	Figures 3 and 5, $R_{DIFF} = 54\Omega$, $C_{L1} = C_{L2} = 100pF$			250	ns
Driver Rise or Fall Time	t_{DR} , t_{DF}	Figures 3 and 5, $R_{DIFF} = 54\Omega$, $C_{L1} = C_{L2} = 100pF$	200	1200	2200	ns
Maximum Data Rate	f_{MAX}		250			kbps
Driver Enable to Output High	t_{DZH}	Figures 4 and 6, $C_L = 100pF$, S2 closed			3500	ns
Driver Enable to Output Low	t_{DZL}	Figures 4 and 6, $C_L = 100pF$, S1 closed			3500	ns
Driver Disable Time from Low	t_{DLZ}	Figures 4 and 6, $C_L = 15pF$, S1 closed			300	ns
Driver Disable Time from High	t_{DHZ}	Figures 4 and 6, $C_L = 15pF$, S2 closed			300	ns
Receiver Input to Output	t_{RPLH} , t_{RPHL}	Figures 7 and 9; $ V_{ID} \geq 2.0V$		440	600	ns
Differential Receiver Skew $t_{RPLH} - t_{RPHL}$	t_{RSKEW}	Figures 7 and 9; $ V_{ID} \geq 2.0V$		20		ns
Receiver Enable to Output Low	t_{RZL}	Figures 2 and 8, $C_L = 100pF$, S1 closed		20	50	ns
Receiver Enable to Output High	t_{RZH}	Figures 2 and 8, $C_L = 100pF$, S2 closed		20	50	ns
Receiver Disable Time from Low	t_{RLZ}	Figures 2 and 8, $C_L = 100pF$, S1 closed		200	500	ns
Receiver Disable Time from High	t_{RHZ}	Figures 2 and 8, $C_L = 100pF$, S2 closed		200	500	ns
Time to Shutdown	t_{SHDN}	(Note 4)	50	200	700	ns
Driver Enable from Shutdown to Output High	t_{DZH} (SHDN)	Figures 4 and 6, $C_L = 15pF$, S2 closed		0.2	1	ms
Driver Enable from Shutdown to Output Low	t_{DZL} (SHDN)	Figures 4 and 6, $C_L = 15pF$, S1 closed		0.2	1	ms
Receiver Enable from Shutdown to Output High	t_{RZH} (SHDN)	Figures 2 and 8, $C_L = 100pF$, S2 closed		0.2	1	ms
Receiver Enable from Shutdown to Output Low	t_{RZL} (SHDN)	Figures 2 and 8, $C_L = 100pF$, S1 closed		0.2	1	ms
Charge-Pump Oscillating Frequency	f_{OSC}			1.3		MHz

Note 1: All currents into the device are positive; all currents out of the device are negative. All voltages are referred to device ground unless otherwise noted.

Note 2: ΔV_{OD} and ΔV_{OC} are the changes in V_{OD} and V_{OC} , respectively, when the DI input changes state.

Note 3: Current level applies to peak current just prior to foldback-current limiting.

Note 4: The device is put into shutdown by bringing RE high and DE low. If the enable inputs are in this state for less than 50ns, the device is guaranteed not to enter shutdown. If the enable inputs are in this state for at least 700ns, the device is guaranteed to have entered shutdown.

High CMRR RS-485 Transceiver with $\pm 60V$ Isolation

MAX3158

Typical Operating Characteristics

($V_{CC} = +5V$, $YR = ZR = AR = BR = ISOCOM$, $C1 = C2 = 0.047\mu F$, $C3 = 1\mu F$, $C4 = 10nF$, $T_A = +25^\circ C$, unless otherwise noted.)

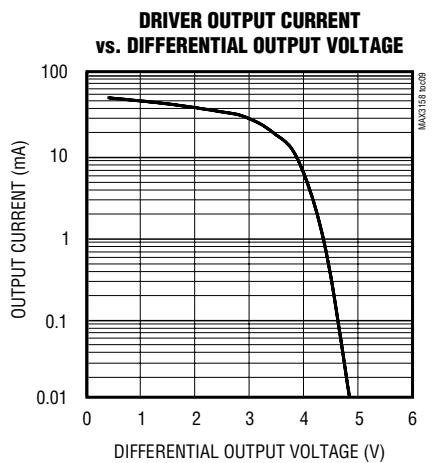
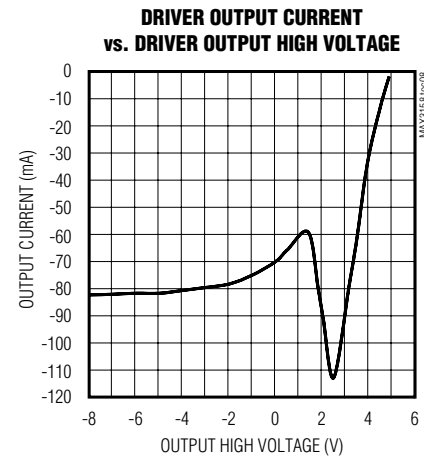
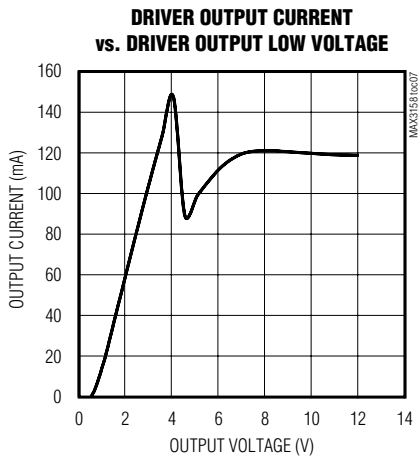
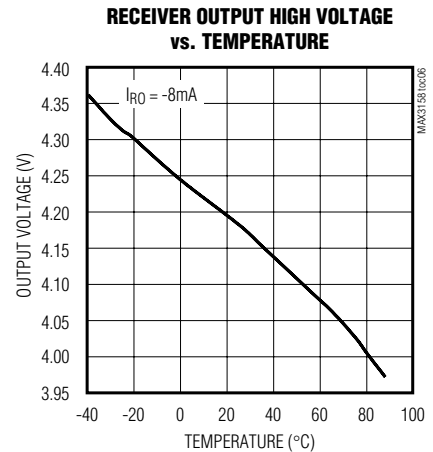
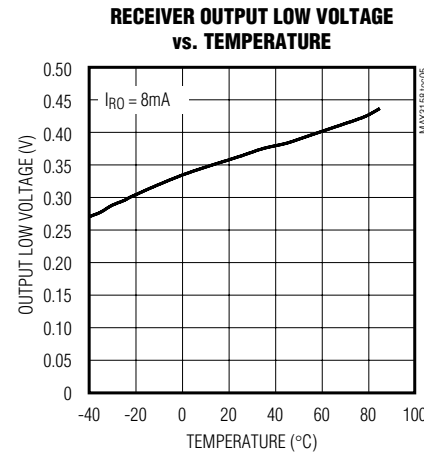
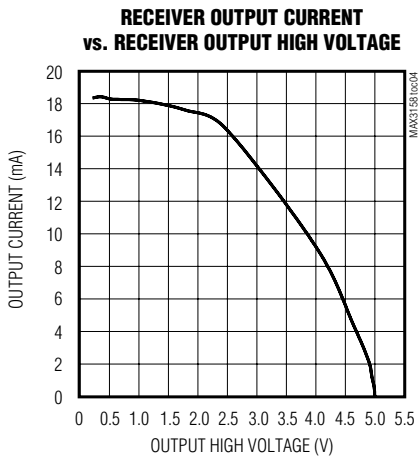
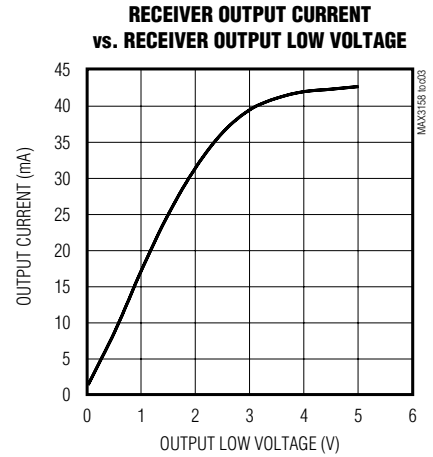
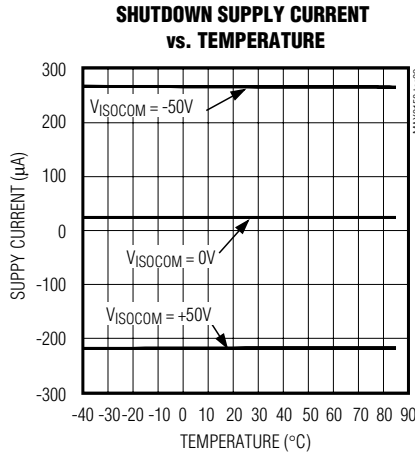
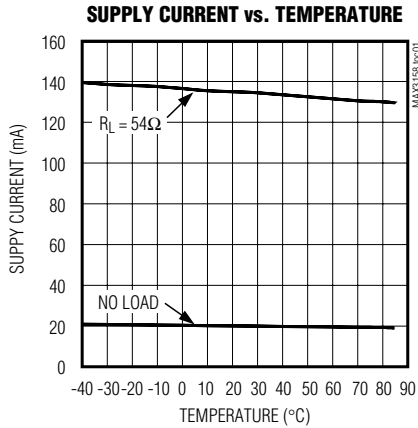

High CMRR RS-485 Transceiver with ±60V Isolation

Typical Operating Characteristics (continued)

(V_{CC} = +5V, YR = ZR = AR = BR = ISOCOM, C1 = C2 = 0.047μF, C3 = 1μF, C4 = 10nF, T_A = +25°C, unless otherwise noted.)

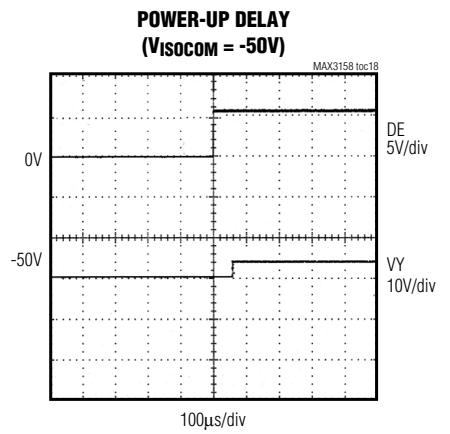
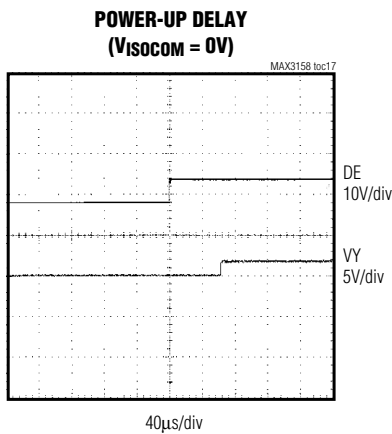
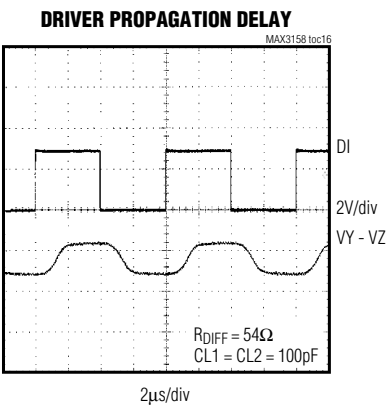
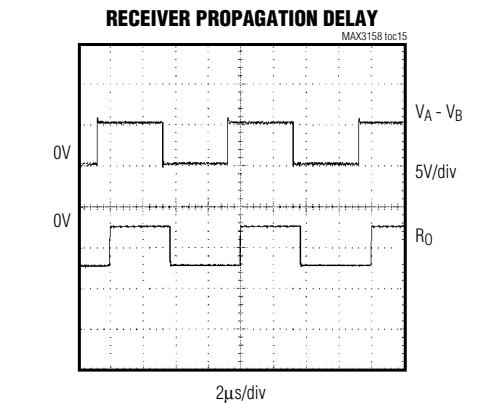
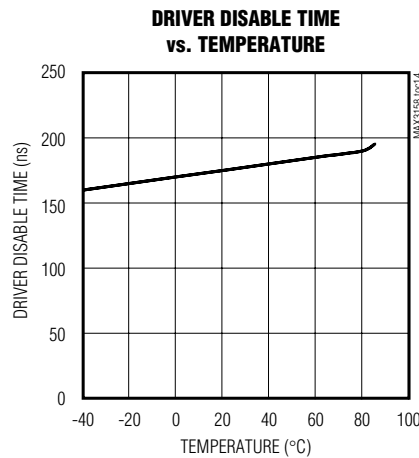
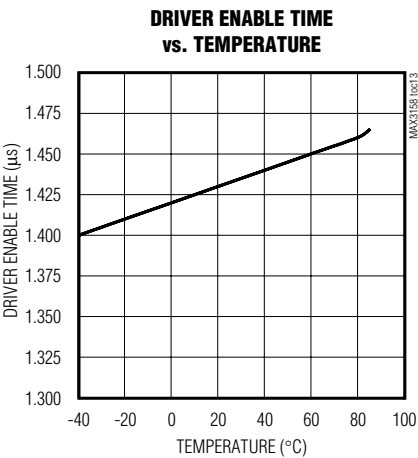
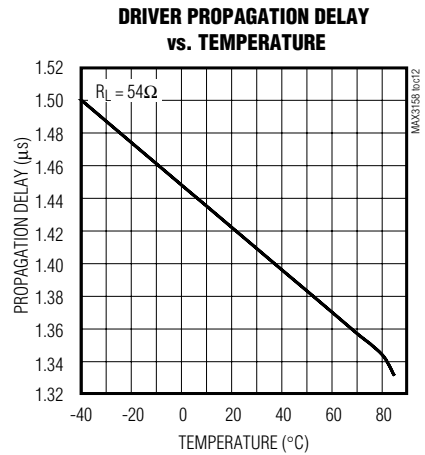
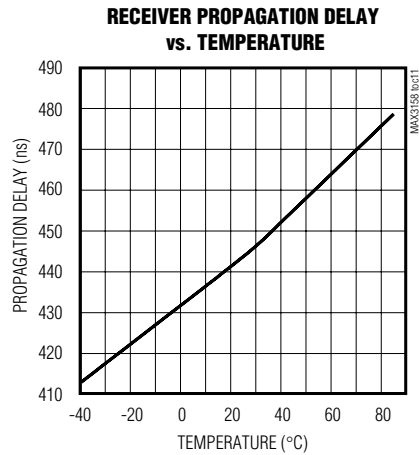
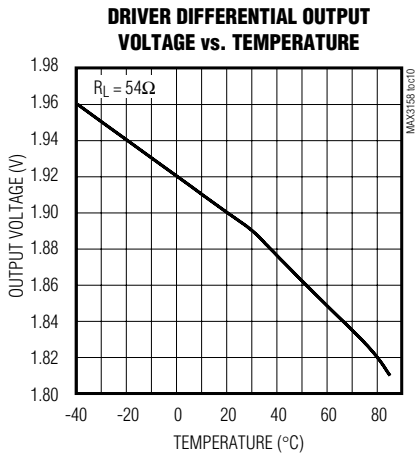

High CMRR RS-485 Transceiver with $\pm 60V$ Isolation

MAX3158

Typical Operating Characteristics (continued)

($V_{CC} = +5V$, $YR = ZR = AR = BR = ISOCOM$, $C1 = C2 = 0.047\mu F$, $C3 = 1\mu F$, $C4 = 10nF$, $T_A = +25^\circ C$, unless otherwise noted.)

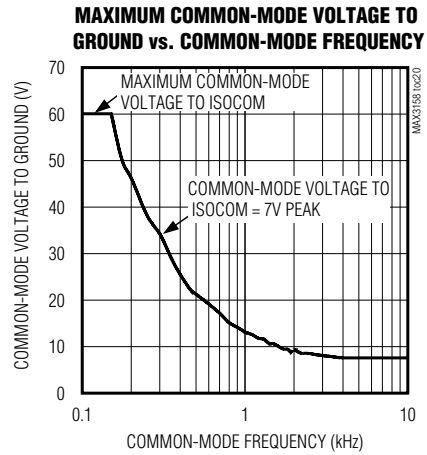
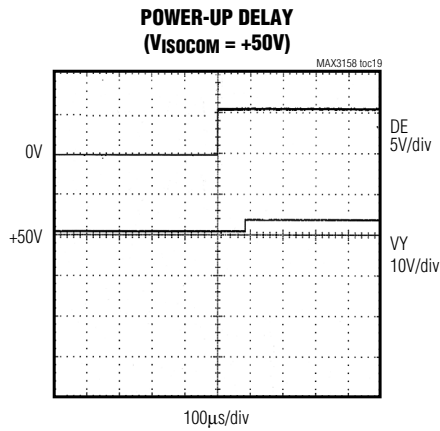

Test Circuits and Timing Diagrams

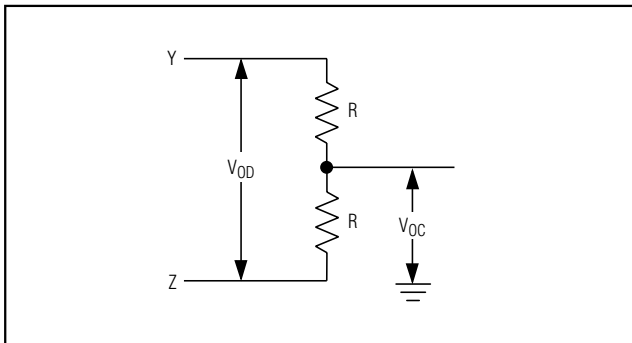

Figure 1. Driver DC Test Load

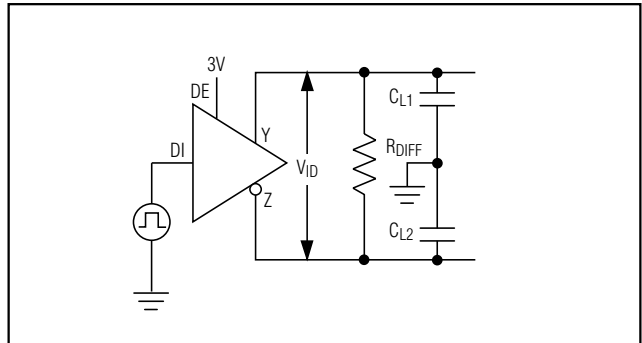

Figure 3. Driver Timing Test Circuit

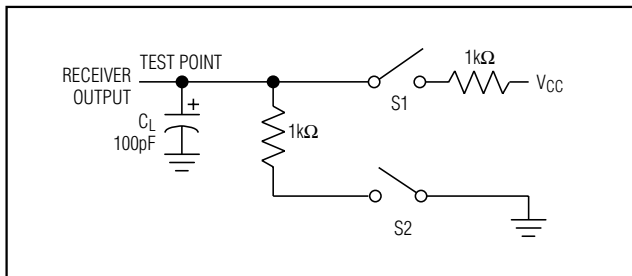

Figure 2. Receiver Enable/Disable Timing Test Load

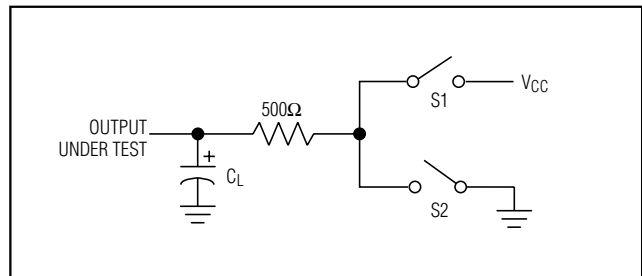

Figure 4. Driver Enable/Disable Timing Test Load

High CMRR RS-485 Transceiver with ±60V Isolation

Test Circuits and Timing Diagrams (continued)

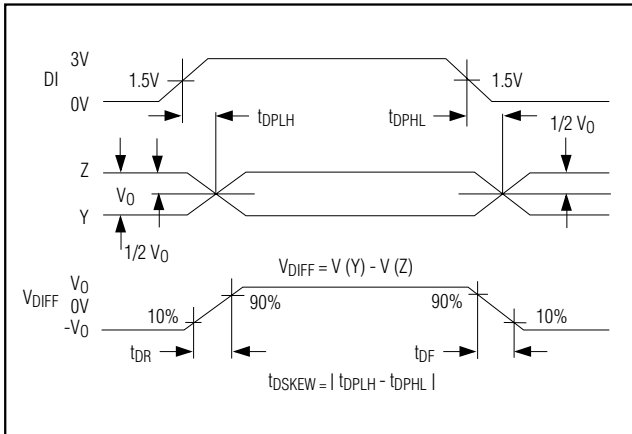

Figure 5. Driver Propagation Delays

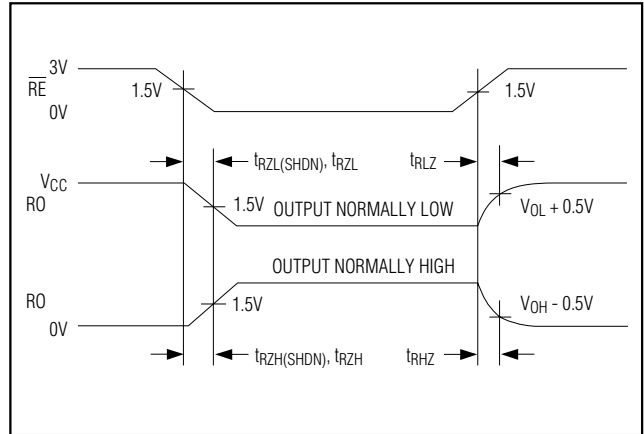

Figure 8. Receiver Enable and Disable Times

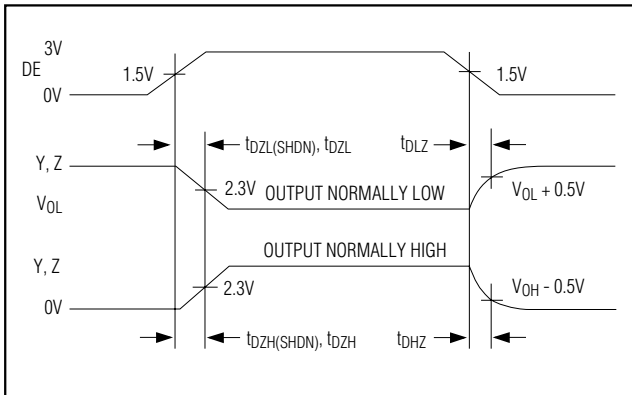

Figure 6. Driver Enable and Disable Times

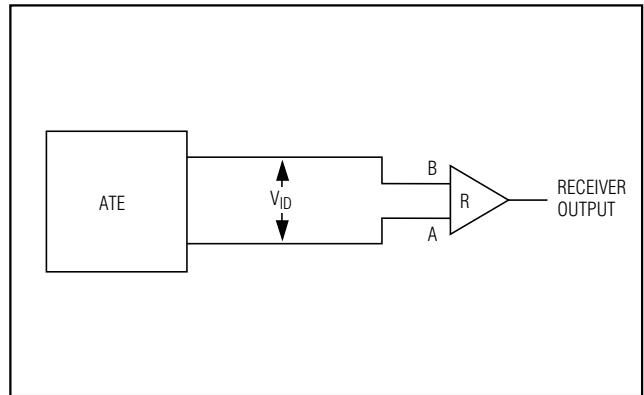

Figure 9. Receiver Propagation Delay Test Circuit

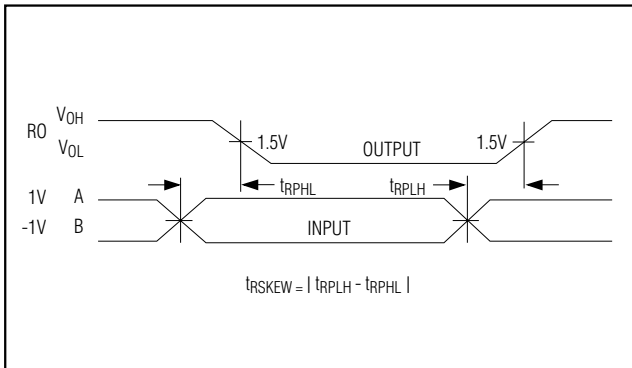

Figure 7. Receiver Propagation Delays

High CMRR RS-485 Transceiver with $\pm 60V$ Isolation

Pin Description

MAX3158

PIN		NAME	FUNCTION
SSOP	PDIP		
1	2	RO	Receiver Output. When \overline{RE} is low and $A - B > -50mV$, RO will be high; if $A - B \leq -200mV$, RO will be low.
2	3	\overline{RE}	Receiver Output Enable. Drive \overline{RE} low to enable RO.
3	4	DE	Driver Output Enable. Drive DE high to enable driver outputs.
4	5	DI	Driver Input. With DE high, a low on DI forces the noninverting output low and the inverting output high; with DI high, outputs reverse.
5	6	C1LO	Connect to the negative terminal of C1 (0.047 μ F, 100V).
6, 7, 12, 22, 23	1, 12, 14, 15, 28	N.C.	No Connection. Not internally connected.
8	7	C1HI	Connect to the positive terminal of C1 (0.047 μ F, 100V).
9	8	ISOVCC	Internally generated power-supply voltage, referenced to the cable ground (ISOCOM). Connect a 1 μ F capacitor to ISOCOM.
10	9	H/ \overline{F}	Half/Full-Duplex Selector Pin. Leave open, or connect to ISOCOM to select Full Duplex, or connect to ISOVCC to select Half Duplex.
11	10	ZR	Connect to ISOCOM for a 1.5k Ω input impedance on Z. Leave open for a 12k Ω input impedance on Z.
13	11	YR	Connect to ISOCOM for a 1.5k Ω input impedance on Y. Leave open for a 12k Ω input impedance on Y.
14	13	ISOCOM	Cable Ground
15	16	Z	Inverting Driver Output (and Inverting Receiver Input in Half-Duplex Mode)
16	17	Y	Noninverting Driver Output (and Noninverting Receiver Input in Half-Duplex Mode)
17	18	B	Inverting Receiver Input in Full-Duplex Mode
18	19	A	Noninverting Receiver Input in Full-Duplex Mode
19	20	BR	Connect to ISOCOM for a 1.5k Ω input impedance on B. Leave open for a 12k Ω input impedance on B.
20	21	AR	Connect to ISOCOM for a 1.5k Ω input impedance on A. Leave open for a 12k Ω input impedance on A.
21	22	C2HI	Connect to the positive terminal of C2 (0.047 μ F, 100V).
24	23	C2LO	Connect to the negative terminal of C2 (0.047 μ F, 100V).
25	24	GND	Ground
26	25	TXP	Transmitter Phase. Leave open, or connect to GND for normal transmitter polarity, or connect to V _{CC} to invert the transmitter polarity.
27	26	RXP	Receiver Phase. Leave open, or connect to GND for normal receiver polarity, or connect to V _{CC} to invert the receiver polarity.
28	27	V _{CC}	+4.75V to +5.25V Positive Supply. Connect a 0.1 μ F capacitor to GND.

High CMRR RS-485 Transceiver with $\pm 60V$ Isolation

Detailed Description

The MAX3158 is a high CMRR RS-485/RS-422 data-communications interface providing $\pm 60V$ isolation in a hybrid microcircuit. A single +5V supply on the logic side powers both sides of the interface, with external 100V capacitors transferring power from the logic side to the isolated side (see *Block Diagram*). The MAX3158 typically draws 25mA of supply current when unloaded or when fully loaded with the driver disabled. Supply current drops to 25 μ A when the device is placed in shutdown mode (see *Low-Power Shutdown Mode* section). The MAX3158 transceiver for RS-485/RS-422 communication contains one driver and one receiver.

This device features fail-safe circuitry, which guarantees a logic-high receiver output when the receiver inputs are open or shorted, or when they are connected to a terminated transmission line with all drivers disabled (see *Fail-Safe* section). The MAX3158 is selectable between half- and full-duplex communication by connecting a selector pin to ISOVCC or ISOCOM, respectively. Drivers are output short-circuit current limited. Thermal shutdown circuitry protects drivers against excessive power dissipation. When activated, the thermal shutdown circuitry places the driver outputs into a high-impedance state. The device also features independently programmable receiver and transmitter output phase through separate pins. The MAX3158 is a low-cost replacement for opto-isolated transceivers.

Fail-Safe

The MAX3158 **guarantees** a logic-high receiver output when the receiver inputs are shorted or open, or when they are connected to a terminated transmission line with all drivers disabled. The receiver threshold is fixed between -50mV and -200mV. If the differential receiver input voltage (A - B) is greater than or equal to -50mV, RO is logic high. If A - B is less than or equal to -200mV, RO is logic low. In the case of a terminated bus with all transmitters disabled, the receiver's differential input voltage is pulled to 0V by the termination. With the receiver thresholds of the MAX3158, this results in a logic high with a 50mV minimum noise margin. Unlike competitor's fail-safe devices, the -50mV to -200mV threshold complies with the $\pm 200mV$ EIA/TIA-485 standard.

MAX3158 Programming

The MAX3158 has several programmable operating modes. Occasionally, twisted-pair lines are reversed. The MAX3158 has two pins that invert the phase of the driver and the receiver to correct for this problem. For normal operation, drive TXP and RXP low, connect them to ground, or leave them unconnected (internal pulldown). To invert the driver phase, drive TXP high or

connect it to VCC. To invert the receiver phase, drive RXP high or connect it to VCC. Note that the receiver threshold is positive when RXP is high.

The MAX3158 can operate in full- or half-duplex mode. Connect H/ \bar{F} to ISOCOM for full-duplex mode, and connect it to ISOVCC for half-duplex operation. In half-duplex mode, the receiver inputs are switched to the driver outputs, connecting outputs Y and Z to inputs A and B, respectively. In half-duplex mode, the internal full-duplex receiver input resistors are still connected to pins A and B.

Low-Power Shutdown Mode

The low-power shutdown mode is initiated by bringing both \bar{RE} high and DE low. In shutdown, this device typically draws only 25 μ A of supply current, and no power is transferred across the isolation capacitors in this mode. \bar{RE} and DE may be driven simultaneously; the parts are guaranteed not to enter shutdown if \bar{RE} is high and DE is low for less than 50ns. If the inputs are in this state for at least 700ns, the parts are guaranteed to enter shutdown. Enable times t_{ZH} and t_{ZL} in the *Switching Characteristics* table assume the part was not in a low-power shutdown state. Enable times $t_{ZH}(SHDN)$ and $t_{ZL}(SHDN)$ assume the parts were shut down. It takes drivers and receivers longer to become enabled from low-power shutdown mode $t_{ZH}(SHDN)$, $t_{ZL}(SHDN)$ than from driver/receiver-disable mode (t_{ZH} , t_{ZL}).

Driver Output Protection

Two mechanisms prevent excessive output current and power dissipation caused by faults or by bus contention. The first, a foldback current limit on the output stage, provides immediate protection against short circuits over the whole common-mode voltage range (see *Typical Operating Characteristics*). The second, a thermal shutdown circuit, forces the driver outputs into a high-impedance state if the die temperature becomes excessive—typically around +150°C.

Applications Information

Capacitor and Grounding Resistor Selection

The value for the charge-pump capacitors C1 and C2 should be between 47nF and 100nF. Smaller values will result in insufficient supply voltage on the isolated side. Larger values are allowed but will not result in better charge-pump capacity. The values for C1 and C2, as well as that of C4, determine the maximum frequency and amplitude of the voltage difference (under operating conditions) between the local and isolated ground. Besides the capacitor values, this maximum frequency

High CMRR RS-485 Transceiver with $\pm 60V$ Isolation

Block Diagram

MAX3158

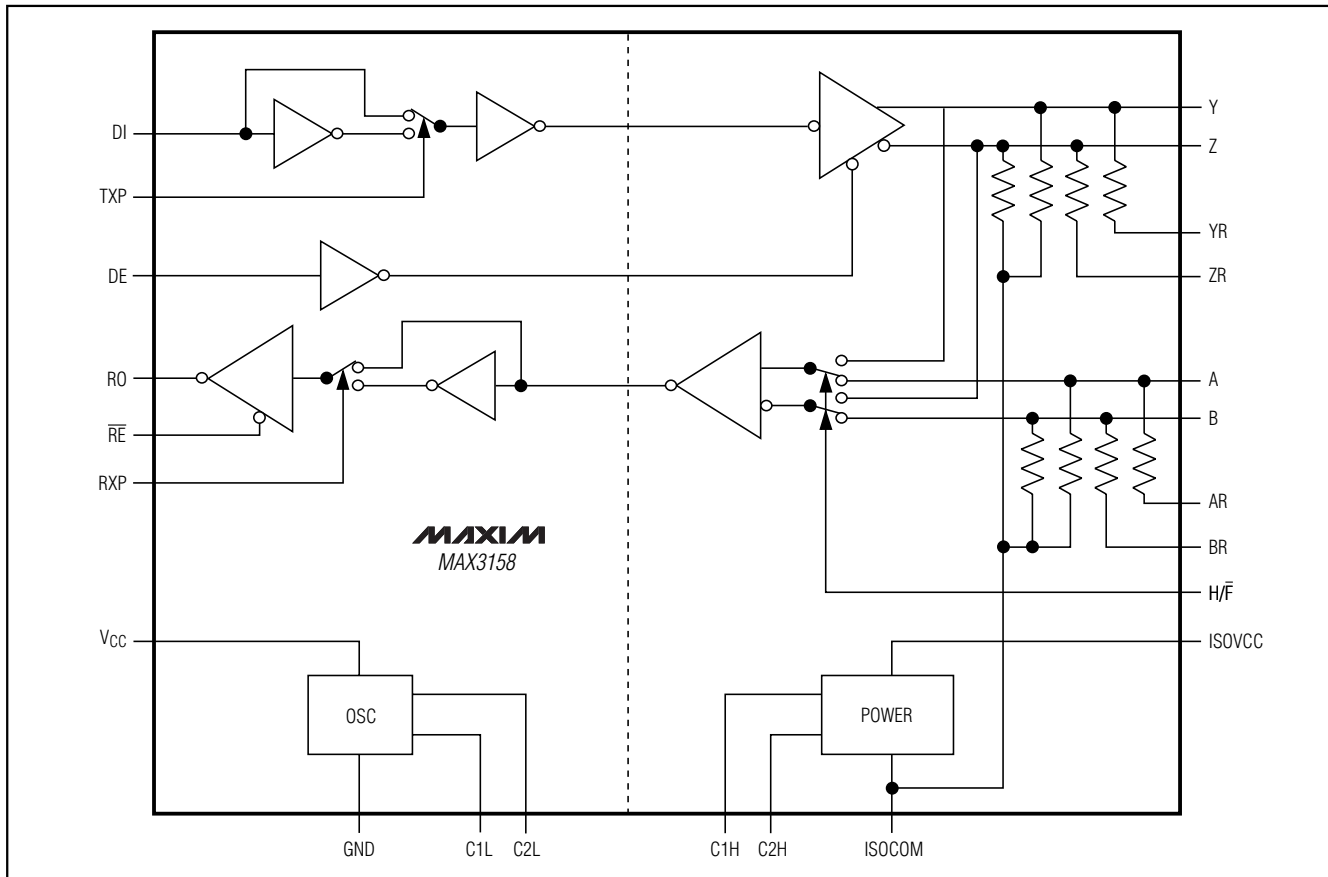

and amplitude are also determined by the resistance between the remote ground and the ISOCOM pin. The receiver input resistors will cause the isolated common voltage to go to the mean voltage of the receiver inputs, which will be a direct function of the remote ground potential. The receiver input resistance and the capacitors C1, C2, and C4 set up a time constant that limits how fast the ISOCOM pin can follow variations in the remote ground voltage. Connecting YR and ZR in half-duplex operation, or AR and BR in full-duplex operation, to ISOCOM results in a relatively low input impedance of the MAX3158 receiver inputs ($2k\Omega$). This allows for a 60Hz sine wave with a 60V maximum amplitude (see *Typical Operating Characteristics*). If YR, ZR, AR, and BR are left open, the receiver input impedance is $12k\Omega$ allowing up to 32 transceivers on the bus. To guarantee the same low time constant under those conditions, use a shielded cable with a $1k\Omega$ resistor connected between

the shield and ISOCOM. Using a lower value for this resistor is not recommended because this could trigger a holding current in the internal ESD protection device if the $\pm 75V$ isolation limit is exceeded.

A single point hard-ground connection for the shield is recommended.

Communication Between Two MAX3158s

If two MAX3158 devices are used to communicate with each other, one of the devices must have ISOCOM connected to local ground. Failure to do so will result in floating ISOCOM pins, with both devices trying to adapt to the isolated ground of the other.

Chip Information

TRANSISTOR COUNT: 1309

High CMRR RS-485 Transceiver with $\pm 60V$ Isolation

Pin Configurations

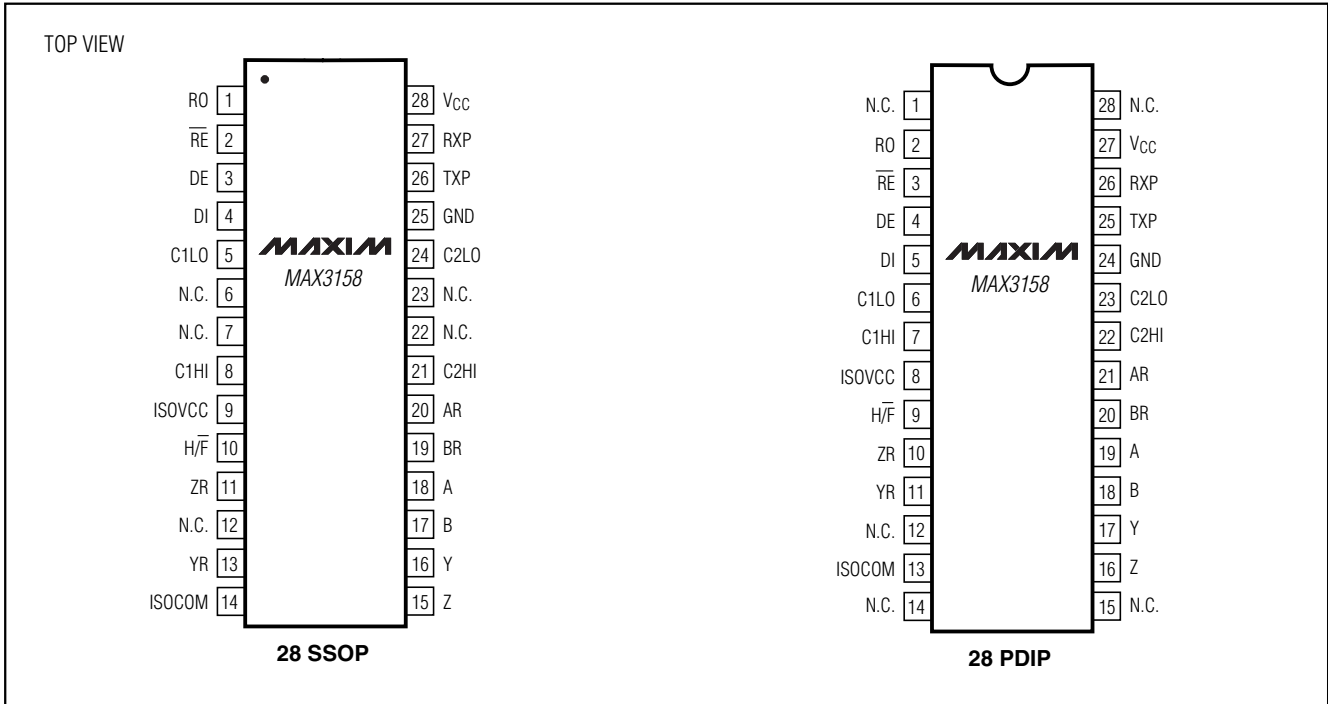

High CMRR RS-485 Transceiver with $\pm 60V$ Isolation

Package Information

(The package drawing(s) in this data sheet may not reflect the most current specifications. For the latest package outline information, go to www.maxim-ic.com/packages.)

MAX3158

SSOP-EPS

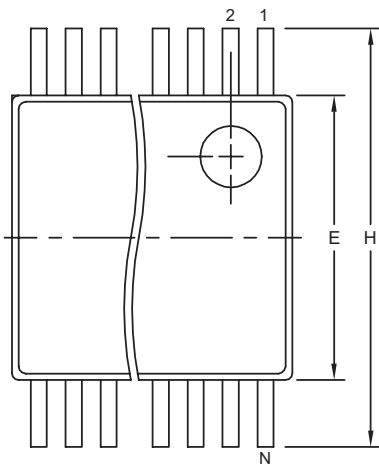

DIM	INCHES		MILLIMETERS	
	MIN	MAX	MIN	MAX
A	0.068	0.078	1.73	1.99
A1	0.002	0.008	0.05	0.21
B	0.010	0.015	0.25	0.38
C	0.004	0.008	0.09	0.20
D	SEE VARIATIONS			
E	0.205	0.212	5.20	5.38
e	0.0256 BSC		0.65 BSC	
H	0.301	0.311	7.65	7.90
L	0.025	0.037	0.63	0.95
α	0 $^\infty$	8 $^\infty$	0 $^\infty$	8 $^\infty$

D	INCHES		MILLIMETERS		N
	MIN	MAX	MIN	MAX	
D	0.239	0.249	6.07	6.33	14L
D	0.239	0.249	6.07	6.33	16L
D	0.278	0.289	7.07	7.33	20L
D	0.317	0.328	8.07	8.33	24L
D	0.397	0.407	10.07	10.33	28L

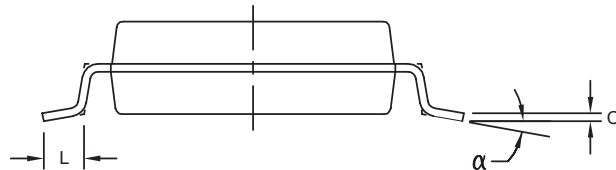
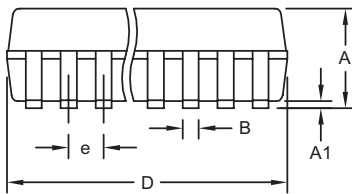

NOTES:

1. D&E DO NOT INCLUDE MOLD FLASH.
2. MOLD FLASH OR PROTRUSIONS NOT TO EXCEED .15 MM (.006").
3. CONTROLLING DIMENSION: MILLIMETERS.
4. MEETS JEDEC MO150.
5. LEADS TO BE COPLANAR WITHIN 0.10 MM.

<small>PROPRIETARY INFORMATION</small>		
TITLE: PACKAGE OUTLINE, SSOP, 5.3 MM		
<small>APPROVAL</small>	<small>DOCUMENT CONTROL NO.</small> 21-0056	<small>REV.</small> C 1/1

High CMRR RS-485 Transceiver with ±60V Isolation

Package Information (continued)

(The package drawing(s) in this data sheet may not reflect the most current specifications. For the latest package outline information, go to www.maxim-ic.com/packages.)

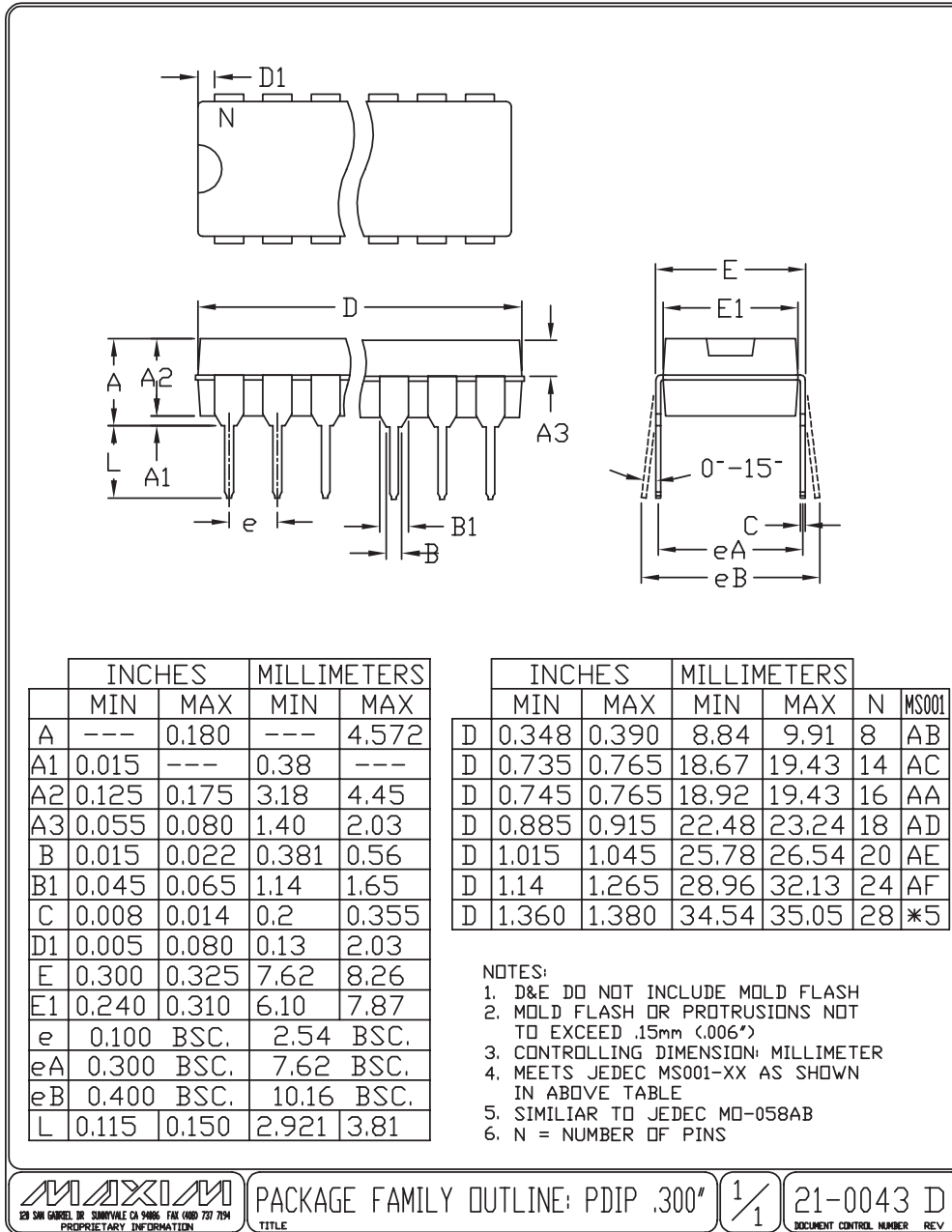

PDFN1EPS



PACKAGE FAMILY OUTLINE: PDIP .300"



21-0043 D

Maxim cannot assume responsibility for use of any circuitry other than circuitry entirely embodied in a Maxim product. No circuit patent licenses are implied. Maxim reserves the right to change the circuitry and specifications without notice at any time.

14 Maxim Integrated Products, 120 San Gabriel Drive, Sunnyvale, CA 94086 408-737-7600

X-ON Electronics

Largest Supplier of Electrical and Electronic Components

Click to view similar products for [RS-422/RS-485 Interface IC category](#):

Click to view products by [Maxim manufacturer](#):

Other Similar products are found below :

[NSI83085](#) [WS3088EESA-GEC](#) [ADM2687EBRIZ-RL7](#) [MAX489CPD+](#) [MAX485ESA+T](#) [MAX491EPD+](#) [MAX488EESA+](#) [MAX3080CPD+](#)
[MXL1535EEWI+](#) [SN65LBC173DR](#) [DS16F95J/883](#) [MAX490ESA+T](#) [LTM2881IY-3#PBF](#) [LT1791CN#PBF](#) [LTM2881CY-3#PBF](#)
[LTC2852CDD#PBF](#) [LTC2857IMS8-2#PBF](#) [LT1791ACN#PBF](#) [LTC487CS#PBF](#) [MAX1487CUA+T](#) [XR3074XID-F](#) [XR3082XID-F](#)
[SP1481EEN-L](#) [SN75ALS173NSR](#) [ADM3491ARZ-REEL](#) [ADM485JN](#) [ADM1485ANZ](#) [ADM1485JNZ](#) [ADM1490EBRMZ](#) [ADM489ABRZ](#)
[ADM1491EBRZ-REEL7](#) [ADM3070EYRZ](#) [ADM3073EARZ](#) [ADM4850ACPZ-REEL7](#) [ADM4850ARMZ-REEL7](#) [ADM485ANZ](#)
[ADM485ARMZ](#) [ADM485JNZ](#) [ADM488ANZ](#) [ADM489ANZ](#) [ADM489ARUZ](#) [ADM3488ARZ](#) [ADM3488EARZ](#) [ADM3490ARZ](#)
[ADM3493ARZ](#) [ADM4856ARZ-REEL7](#) [ADM487EARZ-REEL7](#) [ADM488ABRZ](#) [ADM1486ARZ](#) [ADM3075EWYRZ](#)