

MAX31730

3-Channel Remote Temperature Sensor

General Description

The MAX31730 temperature sensor monitors its own temperature and the temperatures of three external diode-connected transistors. The operating supply voltage is from 3.0V to 3.6V. Resistance cancellation compensates for high series resistance in circuit-board traces and the external thermal diode, while beta compensation corrects for temperature-measurement errors due to low-beta sensing transistors.

All temperature channels have programmable temperature thresholds. When the measured temperature of a channel crosses the respective threshold, a status bit is set in the thermal status registers and the open-drain **THERM** output asserts. A highest temperature register allows the master to obtain the temperature of the hottest channel.

The 2-wire serial interface accepts SMBus protocols (write byte, read byte, send byte, and receive byte) for reading the temperature data and programming the temperature thresholds. Any one of eight available slave addresses can be selected using the address selection input (ADD), which can be connected to ground or connected to a grounded resistor.

The MAX31730 supports 3.0V to 3.6V operation and is specified for a -40°C to +125°C operating temperature range. It is available in a 10-pin μ MAX® and a 12-pin, 3mm x 3mm TDFN package.

Benefits and Features

- Highest Temperature Register Simplifies and Speeds Overtemperature Notification
- Accurate Temperature Measurement Helps Designers Meet Error Budgets
 - 12-Bit, 0.0625°C Resolution
 - $\pm 1^\circ\text{C}$ Remote Temperature-Measurement Accuracy (0°C to +100°C)
 - -64°C to +150°C Remote Temperature-Measurement Range
- Resistance Cancellation for Remote Channels
- Compensation for Low Beta Transistors
- Programmable Temperature Thresholds
- Integration Reduces Cost, Board Area, Power-Supply Current, and Slave Address Usage
 - One Local and Three Remote Temperature-Sensing Channels
 - Eight Selectable Slave Addresses
- Flexible SMBus/I²C Bus Interfaces to a Variety of Microcontrollers

Ordering Information appears at end of data sheet.

For related parts and recommended products to use with this part, refer to www.maximintegrated.com/MAX31730.related.

Typical Application Circuits

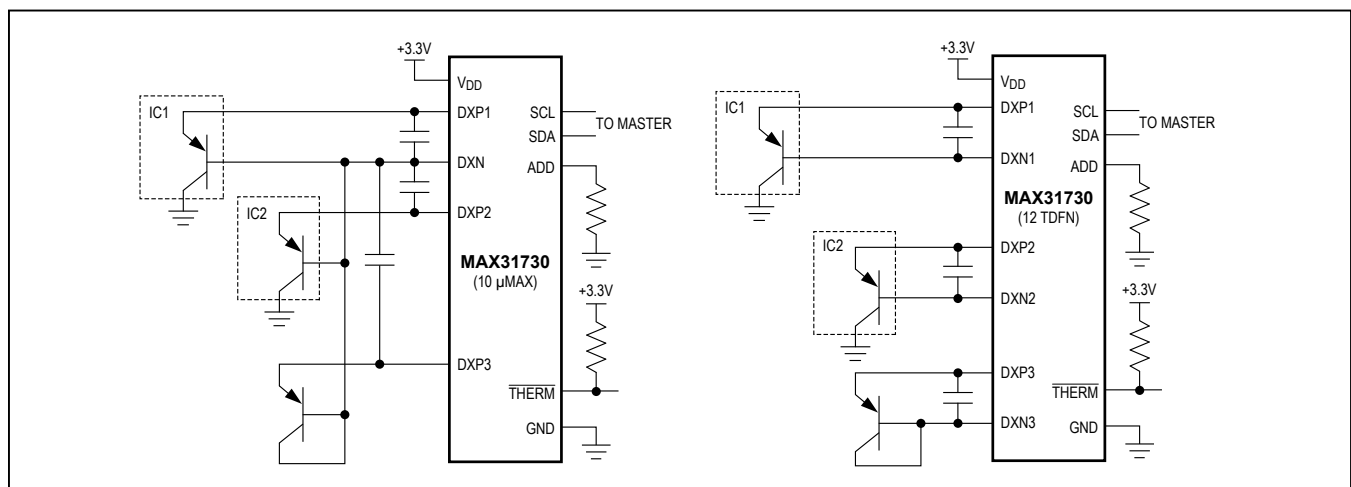

μ MAX is a registered trademark of Maxim Integrated Products, Inc.

Absolute Maximum Ratings

V_{DD}, SCL, SDA, THERM, ADD.....-0.3V to +3.7V
 All Other Pins-0.3V to (V_{DD} + 0.3V)
 ESD Protection (All Pins, Human Body Model)2kV
 Continuous Power Dissipation (T_A = +70°C)
 μMAX (derate at 8.8mW/°C above +70°C)707.30mW
 TDFN (derate 24.4mW/°C above +70°C).....1951.2mW

Operating Temperature Range..... -40°C to +125°C
 Junction Temperature..... +150°C
 Storage Temperature Range..... -65°C to +150°C
 Lead Temperature (soldering, 10s)+300°C
 Soldering Temperature (reflow).....+260°C

Stresses beyond those listed under "Absolute Maximum Ratings" may cause permanent damage to the device. These are stress ratings only, and functional operation of the device at these or any other conditions beyond those indicated in the operational sections of the specifications is not implied. Exposure to absolute maximum rating conditions for extended periods may affect device reliability.

Package Thermal Characteristics (Note 1)

μMAX
 Junction-to-Ambient Thermal Resistance (θ_{JA})113.1°C/W
 Junction-to-Case Thermal Resistance (θ_{JC}).....36°C/W

TDFN
 Junction-to-Ambient Thermal Resistance (θ_{JA})41°C/W
 Junction-to-Case Thermal Resistance (θ_{JC}).....8.5°C/W

Note 1: Package thermal resistances were obtained using the method described in JEDEC specification JESD51-7, using a four-layer board. For detailed information on package thermal considerations, refer to www.maximintegrated.com/thermal-tutorial.

Recommended Operating Conditions

(T_A = -40°C to +125°C, unless otherwise noted.) (Note 2)

PARAMETER	SYMBOL	CONDITIONS	MIN	TYP	MAX	UNITS
Voltage Supply	V _{DD}	(Note 3)	3.0	3.3	3.6	V
Input Logic 0	V _{IL}	SDA, SCL (Note 3)	-0.3		+0.8	V
Input Logic 1	V _{IH}	SDA, SCL (Note 3)	2.2		V _{DD} + 0.3	V
C _{EXT} (between DXP and DXN)		β compensation disabled			2200	pF
		β compensation enabled			200	pF

Electrical Characteristics

(3.0V ≤ V_{DD} ≤ 3.6V, T_A = -40°C to +125°C, unless otherwise noted)

PARAMETER	SYMBOL	CONDITIONS	MIN	TYP	MAX	UNITS
Supply Current	I _{DD}	Standby (Note 4)		2.5	7	μA
		Operating, β compensation disabled		700	1200	
Temperature Resolution			-0.0625		+0.0625	°C
Remote Temperature Accuracy		T _A = 0°C to +70°C, T _{RJ} = 0°C to +100°C	-1		+1	°C
		T _A = 0°C to +70°C, T _{RJ} = +100°C to +150°C	-2		+2	
		T _A = -40°C to +125°C, T _{RJ} = -40°C to +125°C	-2.5		+2.5	

Electrical Characteristics (continued)

($3.0V \leq V_{DD} \leq 3.6V$, $T_A = -40^\circ\text{C}$ to $+125^\circ\text{C}$, unless otherwise noted)

PARAMETER	SYMBOL	CONDITIONS	MIN	TYP	MAX	UNITS
Local Temperature Accuracy		$T_A = 0^\circ\text{C}$ to $+70^\circ\text{C}$	-1		+1	°C
		$T_A = -20^\circ\text{C}$ to $+85^\circ\text{C}$	-1.5		+1.5	
		$T_A = -40^\circ\text{C}$ to $+125^\circ\text{C}$	-2		+2	
Temperature Hysteresis		Comparator mode only		2		°C
Conversion Time Per Channel		β compensation disabled			100	ms
		β compensation enabled			150	ms
Conversion Time for All channels		β compensation disabled			350	ms
Remote-Diode Source Current	I_{RJ}	High level		180		μA
		Low level		12		
DXN_ Bias Voltage		Beta compensation disabled			0.3	V
		Beta compensation enabled			0.65	
POR Threshold	V_{POR}	V_{DD} rising edge		2.65	2.8	V
POR Threshold Hysteresis				110		mV
$\overline{\text{THERM}}$ Output Low Voltage	V_{OL}	$I_{SINK} = 1\text{mA}$			100	mV
		$I_{SINK} = 6\text{mA}$			300	
Input Leakage Current	I_{LEAK}	(Note 5)		0.01	1	μA
Output High Leakage Current	$\overline{\text{THERM}}$, SDA				1	μA

I²C AC Electrical Characteristics

($3.0V \leq V_{DD} \leq 3.6V$, $T_A = -40^\circ\text{C}$ to $+125^\circ\text{C}$, timing referenced to $V_{IL(\text{MAX})}$ and $V_{IH(\text{MAX})}$, unless otherwise noted) (Note 6) (Figures 2 and 3)

PARAMETER	SYMBOL	CONDITIONS	MIN	TYP	MAX	UNITS
Serial-Clock Frequency	f_{CLK}				400	kHz
Bus Free Time Between STOP and START Condition	t_{BUF}	$f_{CLK} = 400\text{kHz}$	1.3			μs
Repeated START Condition Setup Time	$t_{SU:STA}$		0.6			μs
START Condition Setup Time		90% of SCL to 90% of SDA, $f_{CLK} = 400\text{kHz}$	0.6			μs
START Condition Hold Time	$t_{HD:STA}$	90% of SDA to 90% of SCL, $f_{CLK} = 400\text{kHz}$	0.6			μs
STOP Condition Setup Time	$t_{SU:STO}$	90% of SCL to 90% of SDA, $f_{CLK} = 400\text{kHz}$	0.6			μs

I²C AC Electrical Characteristics (continued)

($3.0V \leq V_{DD} \leq 3.6V$, $T_A = -40^\circ\text{C}$ to $+125^\circ\text{C}$, timing referenced to $V_{IL(\text{MAX})}$ and $V_{IH(\text{MAX})}$, unless otherwise noted) (Note 6) (Figures 2 and 3)

PARAMETER	SYMBOL	CONDITIONS	MIN	TYP	MAX	UNITS
Clock Low Period	t_{LOW}	10% to 10%	1			μs
Clock High Period	t_{HIGH}	90% to 90%	1			μs
Data-In Hold Time	$t_{\text{HD:DAT}}$	(Note 7)	0.3			μs
Data-In Setup Time	$t_{\text{SU:DAT}}$		100			ns
Receive Clock/Data Rise Time	t_{R}				300	ns
Receive Clock/Data Fall Time	t_{F}				300	ns
Pulse Width of Spike Suppressed	t_{SP}		0		50	ns
Bus Timeout	t_{TIMEOUT}	(Note 8)	25		45	ms

Note 2: Limits are 100% production tested at $T_A = +25^\circ\text{C}$. Limits over the operating temperature range and relevant supply voltage range are guaranteed by design and characterization. Typical values are not guaranteed.

Note 3: All voltages referenced to ground.

Note 4: $\text{SDA} = \text{SCL} = V_{DD}$.

Note 5: Applies to pins SDA, SCL, and ADD.

Note 6: All timing specifications guaranteed by design.

Note 7: A master device must provide a hold time of at least 300ns for the SDA signal to bridge the undefined region of SCL's falling edge.

Note 8: Holding the SDA line low for a time greater than t_{TIMEOUT} causes the device to reset SDA to the idle state of the serial-bus communication (SDA set high).

Typical Operating Characteristics

($3.0V \leq V_{DD} \leq 3.6V$, $T_A = +25^\circ C$, unless otherwise noted.)

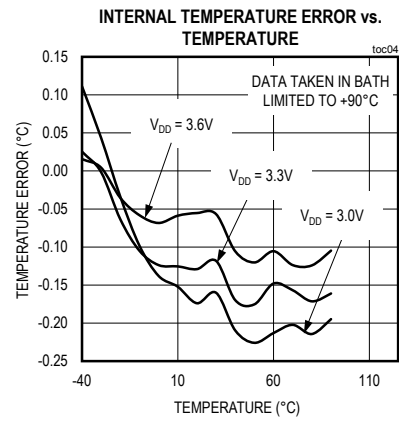
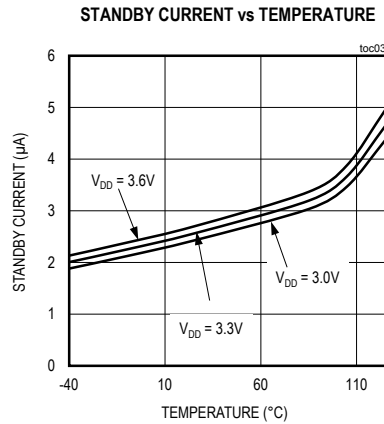
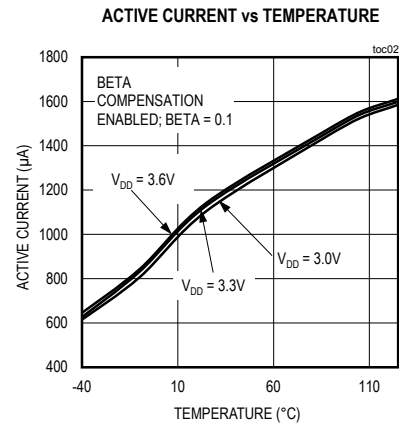
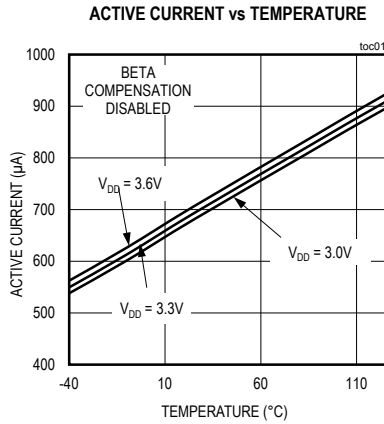

Pin Configurations

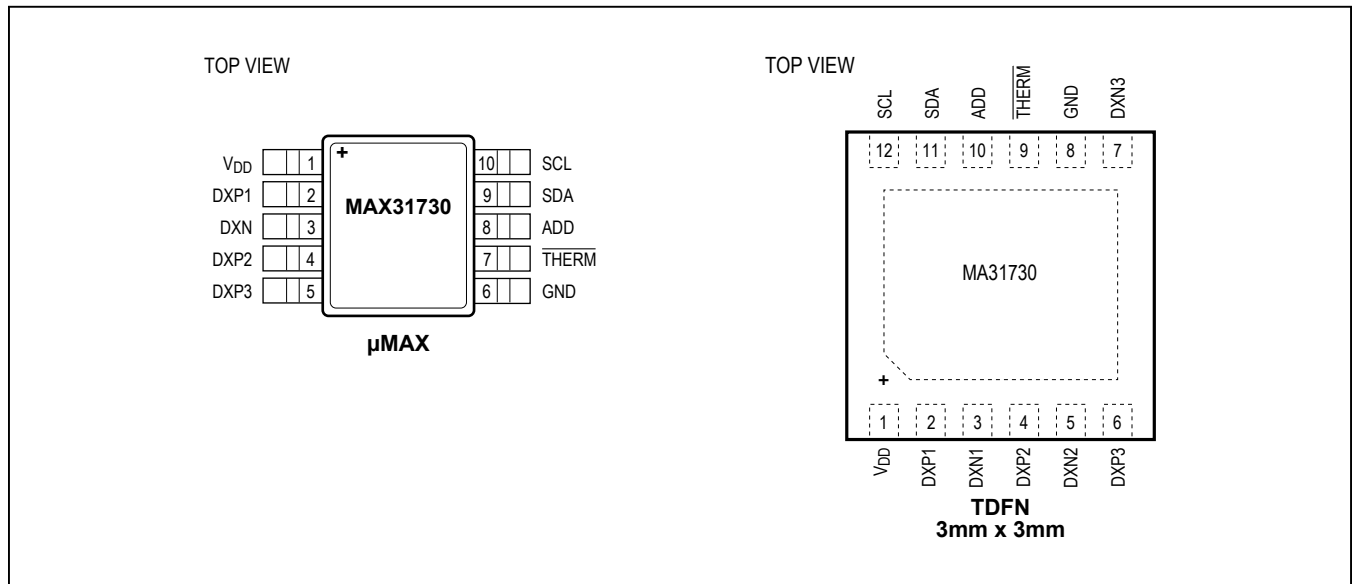

Pin Description

PIN		NAME	FUNCTION
μMAX	TDFN		
1	1	V _{DD}	Supply Voltage Input. Bypass to GND with a 0.1μF capacitor.
2	2	DXP1	Combined Current Source and ADC Positive Input for Channel 1 Remote Diode. Connect DXP1 to the anode of a remote-diode-connected, temperature-sensing transistor. Leave DXP1 unconnected or connect to DXN or DXN1 if the channel 1 remote diode is not used. Connect a capacitor (see the C _{EXT} specification in the <i>Electrical Characteristic</i> table) between DXP1 and DXN or DXN1 for noise filtering.
—	3	DXN1	Cathode Input for Channel 1 Remote Diode. Connect the cathode of the channel 1 remote-diode-connected transistor to DXN1. If the channel 1 remote transistor is a substrate PNP (e.g., on a CPU or ASIC die), connect the base of the PNP to DXN1. Leave DXN1 unconnected or connect to DXP1 if a remote diode is not used. Connect a capacitor (see the C _{EXT} specification in the <i>Electrical Characteristic</i> table) between DXP1 and DXN1 for noise filtering.
3	—	DXN	Shared Cathode Input for Remote-Diode Channels. Connect the cathodes of the channel remote-diode-connected transistors to DXN. If a remote transistor is a substrate PNP (e.g., on a CPU or ASIC die), connect the base of the PNP to DXN. Connect a capacitor (see the C _{EXT} specification in the <i>Electrical Characteristic</i> table) between DXP _n and DXN for noise filtering.

Pin Description (continued)

PIN		NAME	FUNCTION
μMAX	TDFN		
4	4	DXP2	Combined Current Source and ADC Positive Input for Channel 2 Remote Diode. Connect DXP2 to the anode of a remote-diode-connected, temperature-sensing transistor. Leave DXP2 unconnected or connect to DXN or DXN2 if a remote diode is not used. Connect a capacitor (see the C_{EXT} specification in the <i>Electrical Characteristic</i> table) between DXP2 and DXN or DXN2 for noise filtering.
—	5	DXN2	Cathode Input for Channel 2 Remote Diode. Connect the cathode of the channel 2 remote-diode-connected transistor to DXN2. If the channel 2 remote transistor is a substrate PNP (e.g., on a CPU die), connect the base of the PNP to DXN2. Leave DXN2 unconnected or connect to DXP2 if a remote diode is not used. Connect a capacitor (see the C_{EXT} specification in the <i>Electrical Characteristic</i> table) between DXP2 and DXN2 for noise filtering.
5	6	DXP3	Combined Current Source and ADC Positive Input for Channel 3 Remote Diode. Connect DXP3 to the anode of a remote-diode-connected, temperature-sensing transistor. Leave DXP3 unconnected or connect to DXN or DXN3 if a remote diode is not used. Connect a capacitor (see the C_{EXT} specification in the <i>Electrical Characteristic</i> table) between DXP3 and DXN or DXN3 for noise filtering.
—	7	DXN3	Cathode Input for Channel 3 Remote Diode. Connect the cathode of the channel 3 remote-diode-connected transistor to DXN3. If the channel 3 remote transistor is a substrate PNP (e.g., on a CPU die), connect the base of the PNP to DXN3. Leave DXN3 unconnected or connect to DXP3 if a remote diode is not used. Connect a capacitor (see the C_{EXT} specification in the <i>Electrical Characteristic</i> table) between DXP3 and DXN3 for noise filtering.
6	8	GND	Ground
7	9	\overline{THERM}	Active-Low, Open-Drain Over/Undertemperature Output. Can also be used as a SMBus alert output by setting the device to interrupt mode using the Configuration register. When enabled, \overline{THERM} asserts low when the temperature of any channel goes beyond a programmed threshold.
8	10	ADD	Address-Select Input. Sampled at power-up. One of eight possible addresses can be selected by connecting ADD to GND, or connecting ADD to a grounded resistor.
9	11	SDA	I ² C/SMBus Serial-Data Input/Output. Connect SDA to a pullup resistor.
10	12	SCL	I ² C/SMBus Serial-Clock Input. Connect SCL to a pullup resistor.

Block Diagram

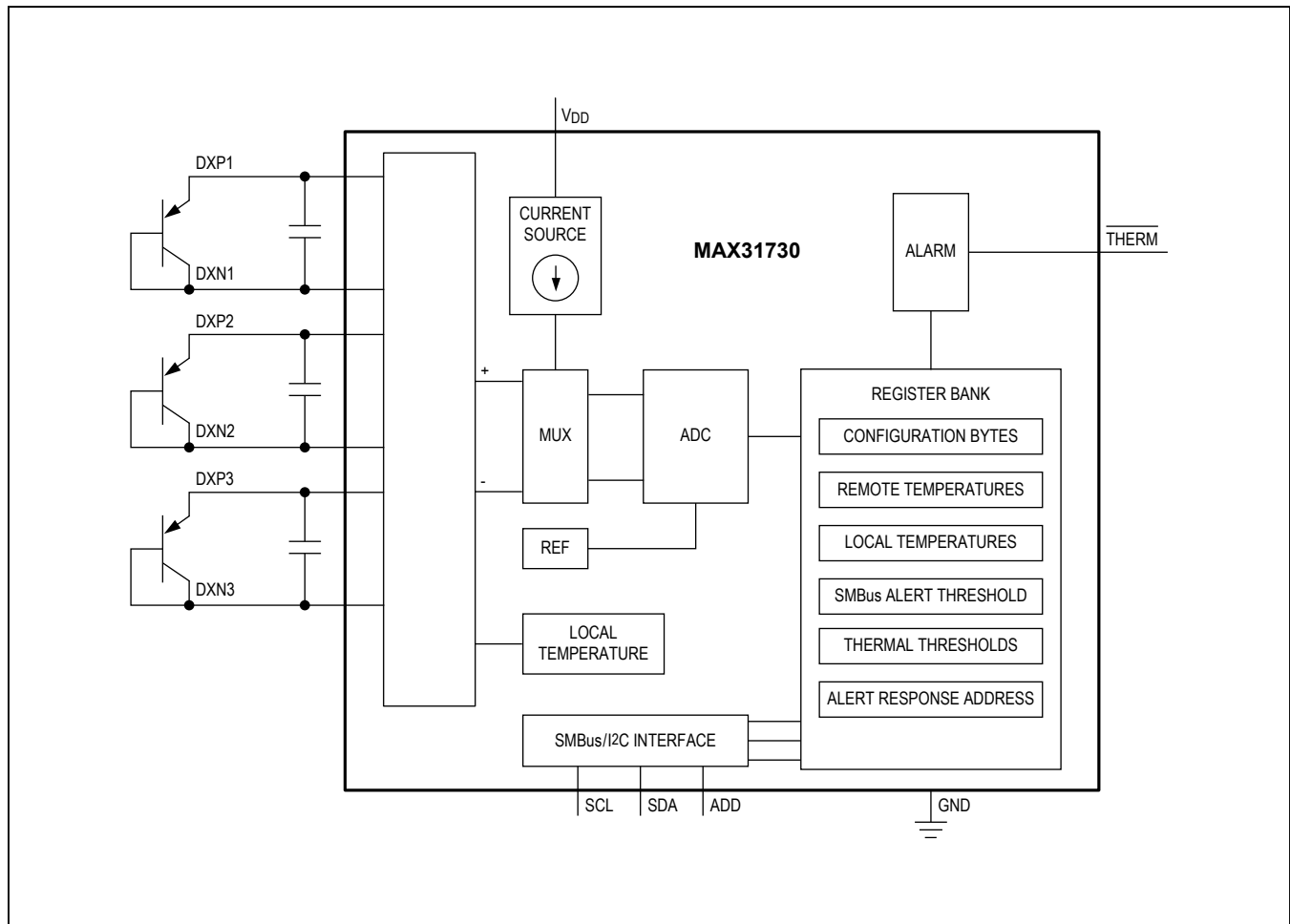

Detailed Description

The MAX31730 is a precision temperature monitor that features one local and three remote temperature-sensing channels, with programmable temperature thresholds for each channel. Communication with the device is achieved through the SMBus/I²C-compatible serial interface and over/undertemperature-detection output ($\overline{\text{THERM}}$). The $\overline{\text{THERM}}$ output asserts if the software-programmed temperature thresholds are exceeded. $\overline{\text{THERM}}$ normally operates in comparator mode and can be connected to a fan, system shutdown, or other thermal-management circuitry. It can also operate in interrupt mode to serve as a SMBus alert interrupt.

ADC Conversion Sequence

The device starts the conversion sequence by measuring the temperature on remote channel 1, followed by remote channel 2, remote channel 3, and the local channel. The conversion result for each enabled channel is stored in the corresponding temperature data register. No conversion is performed on any remote channel that does not have a diode connected, whose DXP_ - DXN_ inputs are shorted together, or that has a short between DXP_ and V_{DD}, DXP_ and GND, or DXN_ and V_{DD}, or if the channel is not enabled in the Highest Temperature Enable register. See the [Register 36h: Diode Fault Status](#) section for additional details.

Series-Resistance Cancellation

Some thermal diodes on high-power ICs have excessive series resistance that can cause temperature-measurement errors when used with conventional remote temperature sensors. External channels 1–3 of the device have a series-resistance cancellation feature that eliminates the effect of diode series resistance and interconnection resistance. The cancellation range is from 0 to 300Ω. Series-resistance cancellation is always enabled.

Low-Power Standby Mode

Enter software-standby mode by setting the STOP bit to 1 in the Configuration register. Software-standby mode disables the ADC and reduces the supply current to approximately 2.5μA. During software standby, data is retained in memory and the bus interface is active and listening for commands. If a START condition is recognized, activity on the bus causes the supply current to increase. If a standby command is received while a conversion is in progress, the conversion cycle is finished, then the device enters shutdown, and the temperature registers are updated.

SMBus Digital Interface

The device is SMBus 2.0 compatible and supports four standard SMBus protocols: write byte, read byte, send byte, and receive byte, as well as multibyte reads and writes (Figure 1). The shorter receive-byte protocol allows quicker transfers, provided that the correct register was previously selected by a read-byte instruction. Use caution with the shorter protocols in multimaster systems, since a second master could overwrite the register byte without informing the first master. Figure 2 is the SMBus write timing diagram and Figure 3 is the SMBus read timing diagram.

The **write-byte** format consists of the master transmitting the slave address, followed by the address for the target register, followed by the 8 bits of data to be written to the target register. To write multiple bytes to two or more contiguous registers, write a new byte after each ACK. The register address then increments after each byte is written. End the transaction with a STOP condition.

The **read-byte** format consists of the master transmitting the slave address followed by the address for the register to be read. The master then begins a new transaction by sending the slave address again, after which the slave returns the data from the selected register. To read multiple bytes from two or more contiguous registers, continue reading after each ACK. The register address then increments after each byte is read. Conclude the overall transaction with a NACK and a STOP condition.

When the first byte of a 2-byte temperature value is read, the device prevents updates of the second byte's contents until the second byte has been read. If the second byte has not been read within a SMBus timeout period (nominally 35ms), it is again allowed to update.

The **send-byte** format can be used to transmit a register address without a transfer of data. It consists of the master transmitting the slave address followed by the address of the target register.

The **receive-byte** format can be used to read data from a register that was previously selected. It consists of the master transmitting the slave address, after which the slave returns the data from the register that was previously selected. After this command completes, the address pointer does not increment.

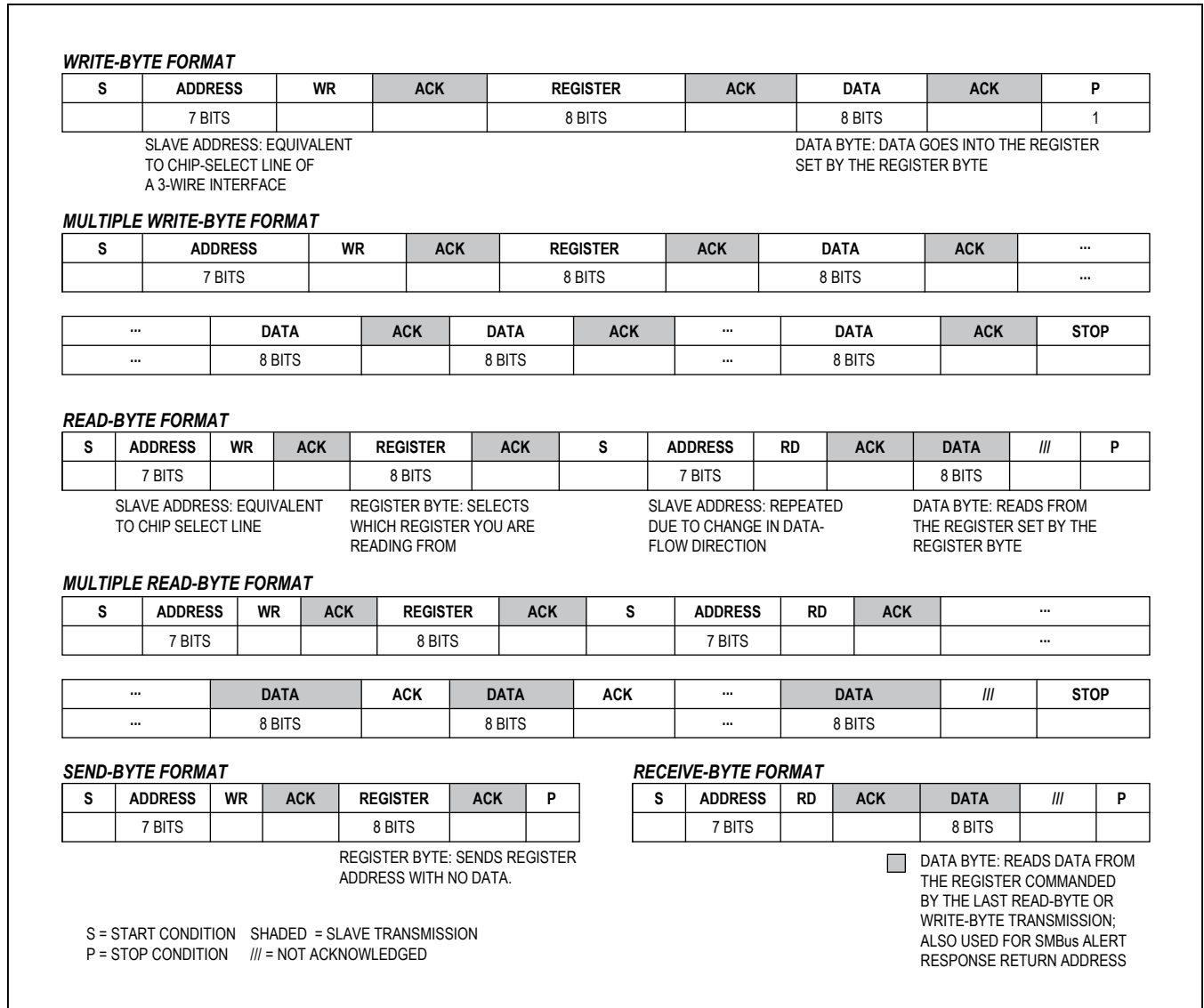

Figure 1. I²C/SMBus Format

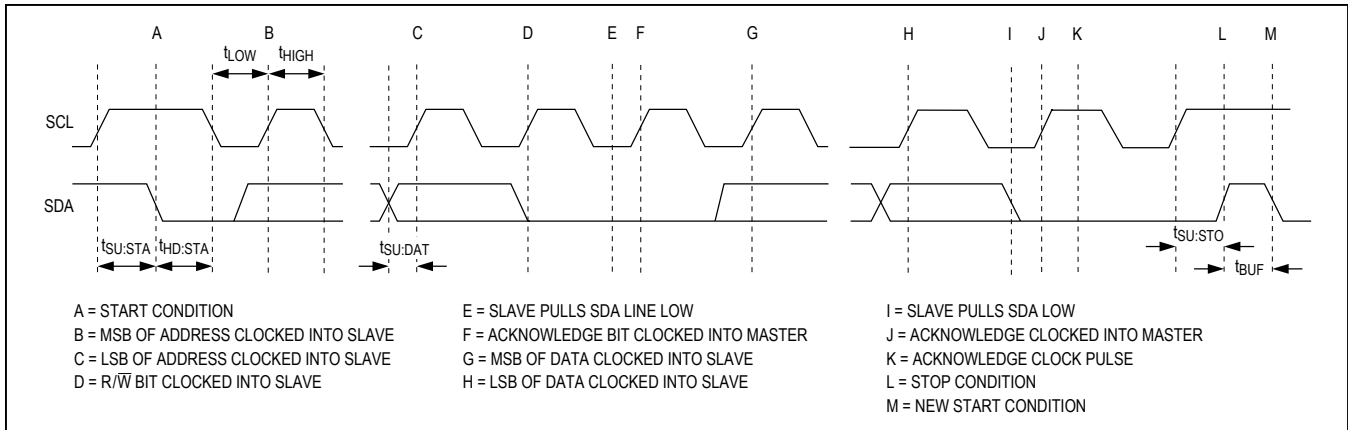

Figure 2. SMBus/I²C Write Timing Diagram

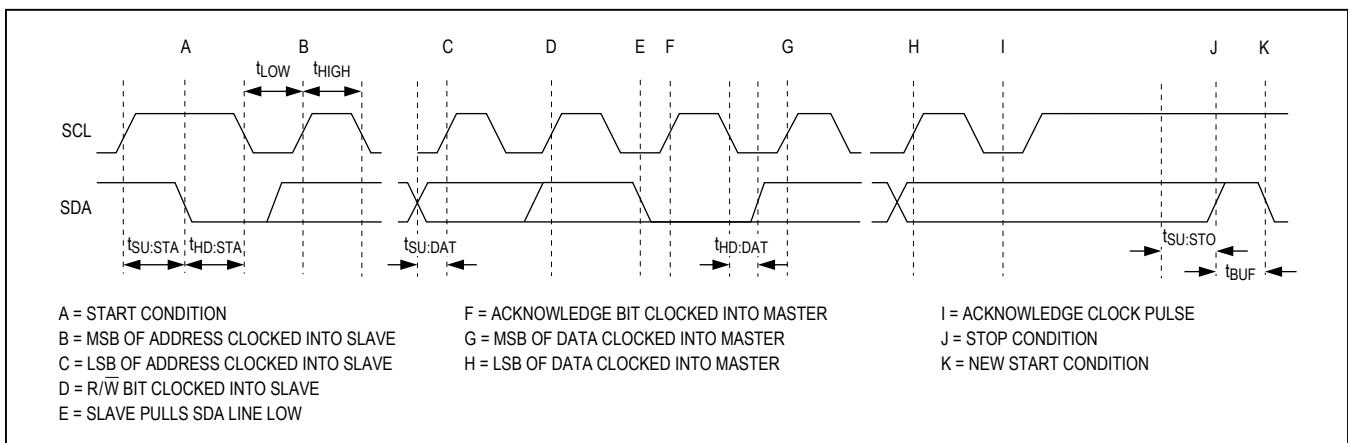

Figure 3. SMBus/I²C Read Timing Diagram

Alert Response Address (ARA)

The SMBus alert response interrupt pointer provides quick fault identification for simple slave devices that lack the complex logic necessary to be a bus master. Upon receiving an interrupt signal, the host master can broadcast a receive-byte transmission to the alert response slave address (19h). Then, any slave device that generated an interrupt attempts to identify itself by putting its own address on the bus. The alert response can activate several different slave devices simultaneously, similar to the I²C general call.

If more than one slave attempts to respond, bus arbitration rules apply, and the device with the lower address code wins. The losing device does not generate an acknowledgment and continues to hold the THERM pin low until cleared (the conditions for clearing an alert vary depending on the type of slave device). Successful completion of the alert response protocol clears the output latch. If the condition that caused the alert still

exists, the device reasserts the interrupt at the end of the next conversion. The device responds to the ARA only when in interrupt mode.

Interrupt Mode

Thermal interrupts occur when the local or remote temperature reading crosses a user-programmable high thermal limit or a low thermal limit. The THERM interrupt output signal can be cleared by reading the status register associated with the fault or by successfully responding to an ARA transmission by the master. In both cases, the thermal fault is cleared but is reasserted at the end of the next conversion if the fault condition still exists. The interrupt does not halt automatic conversions. The THERM output is open drain so that multiple devices can share a common interrupt line. All thermal interrupts can be masked using the THERM Mask register. Interrupt mode can be selected by writing bit 4 in the Configuration register to a 0.

Comparator Mode

Selecting comparator mode in the Configuration register causes the $\overline{\text{THERM}}$ output to assert based on a temperature measurement exceeding a trip threshold value, just as in interrupt mode. However, in comparator mode, the output deasserts automatically when the temperature crosses the threshold back into the acceptable range. A 2°C hysteresis is applied in comparator mode, so clearing the $\overline{\text{THERM}}$ output in this mode requires the temperature to be 2°C less than the high thermal limit and 2°C greater than the low thermal limit.

Temperature Register Format

Temperature data is stored in the temperature, limit, and reference temperature registers. The temperature data

format is 12 bits, two’s complement, and the register is read out in 2 bytes: an upper byte and a lower byte. Bits D[15:0] contain the temperature data, with the LSB representing 0.0625°C and the MSB representing the sign bit (see Table 1). The MSB is transmitted first.

In addition to the normal two’s-complement temperature data format, the device offers an optional extended data format that allows temperatures equal to or greater than +127.9375°C to be read. In the extended format (selected by bit 1 of the Configuration register, 13h), the measured temperature is the value in the temperature register plus 64°C, as shown in Table 2. **Note:** when the extended format is selected, all limit and reference temperature registers must be written in this format. They are not automatically translated by toggling the extended format bit.

Table 1. Temperature, Reference Temperature, Thermal-Limit Register Definition

UPPER BYTE								LOWER BYTE							
D15	D14	D13	D12	D11	D10	D9	D8	D7	D6	D5	D4	D3	D2	D1	D0
Sign bit	MSB 64°C 2 ⁶	32°C 2 ⁵	16°C 2 ⁴	8°C 2 ³	4°C 2 ²	2°C 2 ¹	1°C 2 ⁰	0.5°C 2 ⁻¹	0.25°C 2 ⁻²	0.125°C 2 ⁻³	0.0625 2 ⁻⁴	0	0	0	0

Table 2. Temperature Register Data Format

ACTUAL TEMPERATURE (°C)	NORMAL FORMAT		EXTENDED FORMAT	
	BINARY	HEX	BINARY	HEX
+150	0111 1111 1111 0000	0x7FF0	0101 0110 0000 0000	0x5600
+128	0111 1111 1111 0000	0x7FF0	0100 0000 0000 0000	0x4000
+127	0111 1111 0000 0000	0x7F00	0011 1111 0000 0000	0x3F00
+125	0111 1101 0000 0000	0x7D00	0011 1101 0000 0000	0x3D00
+64	0100 0000 0000 0000	0x4000	0000 0000 0000 0000	0x0000
+25	0001 1001 0000 0000	0x1900	1101 1001 0000 0000	0xD900
+0.5	0000 0000 1000 0000	0x0080	1100 0000 1000 0000	0xC080
0	0000 0000 0000 0000	0x0000	1100 0000 0000 0000	0xC000
-0.5	1111 1111 1000 0000	0xFF80	1011 1111 1000 0000	0xBF80
-25	1110 0111 0000 0000	0xE700	1010 0111 0000 0000	0xA700
-55	1100 1001 0000 0000	0xC900	1000 1001 0000 0000	0x8900
-64	1100 0000 0000 0000	0xC000	1000 0000 0000 0000	0x8000
Diode Fault	0000 0000 0000 0000	0x0000	0000 0000 0000 0000	0x0000

Temperature Channel Enable Register

The Temperature Channel Enable register selects which temperature-sensing channels are enabled. Channels not selected are skipped during the temperature-conversion cycle and diode fault detection is not performed on them. If a channel is deselected while a thermal or diode fault is indicated in the corresponding fault register, the fault bit(s) remain asserted until the register contents are read, and then do not reassert until the channel is again enabled and a fault detected.

Highest Temperature Registers

The Highest Temperature registers (10h and 11h) work with the Reference Temperature registers' (40h through 47h) value for each temperature channel. The Reference

Temperature registers can effectively serve as an offset temperature margin, or their contents can simply be set to zero.

After each temperature conversion, the Reference Temperature value is subtracted from the measured temperature for the corresponding channel (e.g., remote 2 temperature minus remote 2 reference temperature), and the result is compared to the most recent results for the other channels. The highest of all these values is loaded into the Reference Temperature register.

Highest Temperature Enable Register

The Highest Temperature Enable register selects the temperature channels from which the contents of the Highest Temperature register are obtained (see [Table 4](#)).

Table 3. Temperature Channel Enable Register (35h)

BIT	NAME	POR VALUE	FUNCTION
7 (MSB)	Reserved	0	Reserved.
6	Reserved	0	Reserved.
5	Reserved	0	Reserved.
4	Reserved	0	Reserved.
3	Remote 3	1	Channel 3 Enable Bit. Set this bit to logic 1 to enable temperature conversions and diode fault detection for remote channel 3.
2	Remote 2	1	Channel 2 Enable Bit. Set this bit to logic 1 to enable temperature conversions and diode fault detection for remote channel 2.
1	Remote 1	1	Channel 1 Enable Bit. Set this bit to logic 1 to enable temperature conversions and diode fault detection for remote channel 1.
0	Local	1	Local Temperature Channel Enable Bit. Set this bit to logic 1 to enable temperature conversions for the local channel.

Table 4. Highest Temperature Enable Register (12h)

BIT	NAME	POR VALUE	FUNCTION
7 (MSB)	Reserved	1	Reserved.
6	Reserved	1	Reserved.
5	Reserved	1	Reserved.
4	Reserved	1	Reserved.
3	Remote 3	1	Channel 3 Select Bit. Set to logic 1 to use remote channel 3 in determining the highest temperature.
2	Remote 2	1	Channel 2 Select Bit. Set to logic 1 to use remote channel 2 in determining the highest temperature.
1	Remote 1	1	Channel 1 Select Bit. Set to logic 1 to use remote channel 1 in determining the highest temperature.
0	Local	1	Local Select Bit. Set to logic 1 to use local channel in determining the highest temperature.

Thermal-Limit Registers

The Thermal Limit registers (20h through 27h) store over-temperature and undertemperature thermal-threshold values. Access to these registers is provided through the I²C/SMBus-compatible interface. Alarms are masked at power-up. If a threshold is crossed, a bit is set in the Thermal Status registers (40h through 47h) to indicate the thermal fault. The $\overline{\text{THERM}}$ pin is also asserted unless the channel is masked using the $\overline{\text{THERM}}$ Mask register.

Configuration Register

The Configuration register (Table 5) has several functions. Bit 7 (MSB) is used to put the device either in software-standby mode (stop) or continuous-conversion mode.

In standby mode, the ADC is shut down and the supply current reduced. The bus remains active. Bit 6 resets all registers to their POR conditions and then clears itself. Bit 5 disables the bus timeout function. Bit 4 selects whether the $\overline{\text{THERM}}$ output functions as an interrupt or as a comparator. Bits 2 and 3 enable the fault queue, which sets the number of consecutive thermal faults required before asserting the thermal status bits and the $\overline{\text{THERM}}$ output. Bit 1 selects the extended range temperature data format (Table 2), which allows reading temperature values of 127.9375°C or greater. When set to 1, bit 0 begins a single conversion on all enabled temperature channels. This one-shot function can be enabled only when in stop mode.

Table 5. Configuration Register (13h)

BIT	NAME	POR VALUE	FUNCTION
7 (MSB)	STOP	0	Standby-Mode Control Bit. Setting STOP to 1 disables the ADC and reduces supply current to 2.5μA.
6	POR	0	Power-On-Reset Bit. Set to logic 1 to enter the power-on state. This bit is self-clearing.
5	TIMEOUT	0	Timeout Enable Bit. Set to logic 0 to enable SMBus timeout.
4	INTERRUPT/ COMPARATOR	1	Interrupt/Comparator Mode-Select Bit. Set to logic 1 to select comparator mode for the $\overline{\text{THERM}}$ output.
3	FAULT QUEUE	0	Selects the number of consecutive faults needed to assert the Thermal Status bits and $\overline{\text{THERM}}$ output. 00 = 1; 01 = 2; 10 = 4; 11 = 6.
2		0	
1	EXTRANGE	0	Extended-Range Enable Bit. Set bit 1 to logic 1 to set the temperature, limit, and reference data range to maximum reportable temperature of +127.9375°C. Set bit 1 to logic 0 to set the data range to a maximum reportable temperature of +191.9375°C.
0	ONE SHOT	0	Writing 1 to this bit initiates a single cycle of temperature conversions. All other bits in the Configuration register are ignored, and bit 0 automatically resets to 0. ONE SHOT can only be enabled in stop mode.

THERM Mask Register

The THERM Mask register functions are described in [Table 6](#). Bits [3:0] are used to mask the THERM pin output. Bit 0 masks assertion of THERM due to the local channel thermal faults and the remaining bits mask the remote thermal faults. The power-up state of this register is 0000 0000 (00h).

Status Register Functions

The status registers indicate temperature or diode fault status. The Thermal High Status register indicates whether a measured local or remote temperature has exceeded the associated threshold limit set in the associated Thermal High Status register. The Thermal Low Status register indicates whether the measured temperature has fallen below the threshold limit set in the Thermal Low Status register for the local or remote-sensing diodes. The Diode Fault Status register indicates whether there is a diode fault (open or short) in any of the remote-sensing channels.

Bits in the Thermal Status registers are cleared by a successful read, but set again after the next conversion unless the fault is corrected, either by a change in the measured temperature or by a change in the threshold temperature. When in comparator mode, reading the status registers has no effect on the THERM output state; the state depends on the current temperature, threshold, and mask values. Similarly, bits in the Diode Fault Status register are cleared by a successful read, but set again after the next conversion if the fault is still in effect.

In interrupt mode, the THERM output follows the status bits for all unmasked channels. Once the THERM output is asserted while in interrupt mode, it can be deasserted either by reading the thermal status register or by successfully responding to an ARA. In both cases, the THERM pin is cleared even if the fault condition remains in effect, but the THERM output reasserts at the end of the next conversion if the fault condition is still present.

Table 6. THERM Mask Register (34h)

BIT	NAME	POR VALUE	FUNCTION
7(MSB)	Reserved	0	Reserved.
6	Reserved	0	Reserved.
5	Reserved	0	Reserved.
4	Reserved	0	Reserved.
3	Remote 3	0	Channel 3 Remote Mask Bit. Set to logic 1 to mask assertion of <u>THERM</u> due to remote channel 3 thermal fault.
2	Remote 2	0	Channel 2 Remote Mask Bit. Set to logic 1 to mask assertion of <u>THERM</u> due to remote channel 2 thermal fault.
1	Remote 1	0	Channel 1 Remote Mask Bit. Set to logic 1 to mask assertion of <u>THERM</u> due to remote channel 1 thermal fault.
0	Local	0	Local Mask Bit. Set to logic 1 to mask assertion of <u>THERM</u> due to local sensor thermal fault.

Table 7. Thermal High Status Register (32h)

BIT	NAME	POR VALUE	FUNCTION
7 (MSB)	Reserved	0	Reserved.
6	Reserved	0	Reserved.
5	Reserved	0	Reserved.
4	Reserved	0	Reserved.
3	Remote 3	0	Channel 3 Remote-Diode High Thermal Bit. This bit is set to logic 1 when the channel 3 remote-diode temperature exceeds the threshold in the Remote 3 Thermal High Limit registers.
2	Remote 2	0	Channel 2 Remote-Diode High Thermal Bit. This bit is set to logic 1 when the channel 2 remote-diode temperature exceeds the threshold in the Remote 2 Thermal High Limit registers.
1	Remote 1	0	Channel 1 Remote-Diode High Thermal Bit. This bit is set to logic 1 when the channel 1 remote-diode temperature exceeds the threshold in the Remote 1 Thermal High Limit registers.
0	Local	0	Local Channel High Thermal Bit. This bit is set to logic 1 when the local temperature exceeds the threshold in the Local Thermal High Limit registers.

Table 8. Thermal Low Status Register (33h)

BIT	NAME	POR VALUE	FUNCTION
7 (MSB)	Reserved	0	Reserved.
6	Reserved	0	Reserved.
5	Reserved	0	Reserved.
4	Reserved	0	Reserved.
3	Remote 3	0	Channel 3 Remote-Diode Low Thermal Bit. This bit is set to logic 1 when the channel 3 remote-diode temperature is less than the threshold in the Thermal Low Limit registers.
2	Remote 2	0	Channel 2 Remote-Diode Low Thermal Bit. This bit is set to logic 1 when the channel 2 remote-diode temperature is less than the threshold in the Thermal Low Limit registers.
1	Remote 1	0	Channel 1 Remote-Diode Low Thermal Bit. This bit is set to logic 1 when the channel 1 remote-diode temperature is less than the threshold in the Thermal Low Limit registers.
0	Local	0	Local Channel Low Thermal Bit. This bit is set to logic 1 when the local temperature is less than the threshold in the Thermal Low Limit registers.

Diode Fault Detection

If a remote channel's DXP_ and DXN_ inputs are unconnected or are shorted to each other, to ground, or to the supply voltage, the device detects a diode fault. A diode fault does not cause $\overline{\text{THERM}}$ to assert and does not allow an overtemperature or undertemperature event to be detected for the affected channel. A bit in the Diode Fault Status register (36h) corresponding to the channel is set to 1 and the temperature data for the channel is stored as 0°C (0000h in normal format).

A period of approximately 3ms at the beginning of each channel's temperature conversion cycle is dedicated to diode fault detection. Once a diode fault is detected, the temperature conversion for that channel is abandoned and fault detection/temperature conversion begins on the next channel in the conversion sequence. See the [Register 36h: Diode Fault Status](#) section.

Effect of Ideality Factor

The accuracy of the remote temperature measurements depend on the ideality factor (n) of the remote "diode" (actually a diode-connected transistor). The default value for the MAX31730 is $n = 1.008$ (channels 1–3). A thermal diode on the substrate of an external IC is normally a PNP, with the base and emitter brought out and the collector grounded. DXP_ must be connected to the anode (emitter) and DXN_ must be connected to the cathode (base) of this PNP. If a sense transistor with an ideality factor other than 1.008 is used, the output data will be different from the data obtained with the optimum ideality factor. If necessary, a different ideality factor value can be chosen using the Custom Ideality Factor register ([Table 9](#)). The Custom Ideality Enable register ([Table 10](#)) allows each channel to have the default ideality of 1.008 or the value selected in the Custom Ideality Factor register. Note that any change in the ideality selections occur on subsequent conversions; current temperature register values do not change until a new conversion has completed.

Table 9. Custom Ideality Factor Register (14h)

SELECTION (HEX)	IDEALITY FACTOR
0x00	0.9844
0x01	0.9853
0x02	0.9863
0x03	0.9873
0x04	0.9882
0x05	0.9892
0x06	0.9902
0x07	0.991
0x08	0.9921
0x09	0.9931
0x0A	0.9941
0x0B	0.9950
0x0C	0.9960
0x0D	0.9970
0x0E	0.9980
0x0F	0.9990
0x10	1.0000
0x11	1.0010
0x12	1.0020
0x13	1.0030
0x14	1.0040
0x15	1.0050

SELECTION (HEX)	IDEALITY FACTOR
0x16	1.0060
0x17	1.0070
0x18 (default)	1.0080
0x19	1.0090
0x1A	1.0100
0x1B	1.0110
0x1C	1.0120
0x1D	1.0130
0x1E	1.0141
0x1F	1.0151
0x20	1.0161
0x21	1.0171
0x22	1.0182
0x23	1.0192
0x24	1.0202
0x25	1.0213
0x26	1.0223
0x27	1.0233
0x28	1.0244
0x29	1.0254
0x2A	1.0265
0x2B	1.0275

Table 9. Custom Ideality Factor Register (14h) (continued)

SELECTION (HEX)	IDEALITY FACTOR	SELECTION (HEX)	IDEALITY FACTOR
0x2C	1.0286	0x37	1.0402
0x2D	1.0296	0x38	1.0413
0x2E	1.0307	0x39	1.0424
0x2F	1.0317	0x3A	1.0435
0x30	1.0328	0x3B	1.0445
0x31	1.0338	0x3C	1.0456
0x32	1.0349	0x3D	1.0467
0x33	1.0360	0x3E	1.0478
0x34	1.0370	0x3F	1.0489
0x35	1.0381	≥ 0x40	Not Valid
0x36	1.0392		

Table 10. Custom Ideality Enable Register (15h)

BIT	NAME	POR VALUE	FUNCTION
7 (MSB)	Reserved	0	Reserved.
6	Reserved	0	Reserved.
5	Reserved	0	Reserved.
4	Reserved	0	Reserved.
3	Remote 3	0	Channel 3 Remote-Diode Custom Ideality Enable Bit. Write 0 to this bit to select ideality factor = 1.008 for this channel. Write 1 to this bit to select ideality factor determined by the Custom Ideality Factor register.
2	Remote 2	0	Channel 2 Remote-Diode Custom Ideality Enable Bit. Write 0 to this bit to select ideality factor = 1.008 for this channel. Write 1 to this bit to select ideality factor determined by the Custom Ideality Factor register.
1	Remote 1	0	Channel 1 Remote-Diode Custom Ideality Enable Bit. Write 0 to this bit to select ideality factor = 1.008 for this channel. Write 1 to this bit to select ideality factor determined by the Custom Ideality Factor register.
0	Reserved	0	Reserved.

Beta Compensation

Beta compensation corrects for errors caused by low beta-sensing transistors. **Note:** it applies only to PNP transistors with their collectors grounded and their bases and emitters connected to DXN_ and DXP_, respectively (see Figure 4). Select the remote channels for which beta compensation are active using the Beta Compensation Enable register (Table 11). Note that any changes to this register do not change the results currently in the temperature registers or temperature conversion in progress; changes affect subsequent conversion results.

Before beginning a temperature measurement with beta compensation enabled, the device first measures the beta of the target transistor, and then adjusts the drive current level to produce accurate collector current ratios. The beta value registers (Table 12) for the three remote channels contain the minimum beta values for the corresponding transistors.

If a target transistor has a beta less than 0.09, temperature measurement does not work reliably and a temperature measurement is not initiated for that transistor. The diode fault bit is set for the corresponding channel and the temperature registers updated with 0000h. If an attempt at temperature measurement is desired for that remote channel, set the associated Beta Compensation Enable bit to 0. Note that if beta compensation is enabled, the

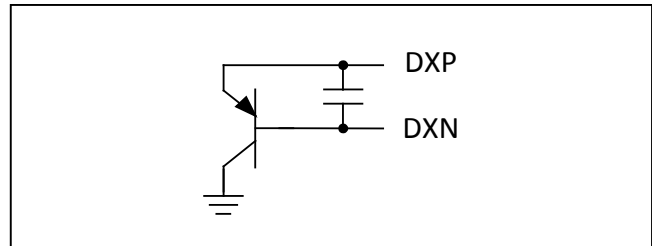

Figure 4. PNP Configuration for use with Beta Compensation.

series resistance in the diode path must be minimized as the series resistance cancellation circuitry will interfere with the beta compensation.

Noise Filter

In noisy environments, it can be useful to average the results of multiple temperature conversion results. Use the Filter Enable register (Table 13) to average the previous four conversions to determine the value stored in the temperature registers. Even when enabled, averaging occurs when performing a one-shot conversion sequence (selected by bit 0 in the Configuration register), so caution should be exercised when long delays occur between one-shot conversions. Note that filtering begins after enabling the filter; the current register contents do not change.

Table 11. Beta Compensation Enable Register (19h)

BIT	NAME	POR VALUE	FUNCTION
7 (MSB)	Reserved	0	Reserved.
6	Reserved	0	Reserved.
5	Reserved	0	Reserved.
4	Reserved	0	Reserved.
3	Remote 3	0	Channel 3 Beta Compensation Enable Bit. Set this bit to logic 1 to enable beta compensation for remote channel 3. Set this bit to logic 0 to disable beta compensation.
2	Remote 2	0	Channel 2 Beta Compensation Enable Bit. Set this bit to logic 1 to enable beta compensation for remote channel 2. Set this bit to logic 0 to disable beta compensation.
1	Remote 1	0	Channel 1 Beta Compensation Enable Bit. Set this bit to logic 1 to enable beta compensation for remote channel 1. Set this bit to logic 0 to disable beta compensation.
0	Reserved	0	Reserved.

Table 12. Beta Compensation Values (Registers 1Ah, 1Bh, and 1Ch) (Read Only)

VALUE (HEX)	BIT 7	BIT 6	BIT 5	BIT 4	BIT 3	BIT 2	BIT 1	BIT 0	BETA (MIN)
0 (default)	Reserved	Reserved	Reserved	Reserved	0	0	0	0	0.67
1	Reserved	Reserved	Reserved	Reserved	0	0	0	1	0.50
2	Reserved	Reserved	Reserved	Reserved	0	0	1	0	0.36
3	Reserved	Reserved	Reserved	Reserved	0	0	1	1	0.30
4	Reserved	Reserved	Reserved	Reserved	0	1	0	0	0.25
5	Reserved	Reserved	Reserved	Reserved	0	1	0	1	0.20
6	Reserved	Reserved	Reserved	Reserved	0	1	1	0	0.15
7	Reserved	Reserved	Reserved	Reserved	0	1	1	1	0.13
8	Reserved	Reserved	Reserved	Reserved	1	0	0	0	0.11
9	Reserved	Reserved	Reserved	Reserved	1	0	0	1	0.09
F	Reserved	Reserved	Reserved	Reserved	1	1	1	1	Low B Fault

Table 13. Filter Enable Register (18h)

BIT	NAME	POR VALUE	FUNCTION
7 (MSB)	Reserved	0	Reserved.
6	Reserved	0	Reserved.
5	Reserved	0	Reserved.
4	Reserved	0	Reserved.
3	Remote 3	0	Channel 3 Filter Enable Bit. Set this bit to logic 1 to enable filter for remote channel 3. Set this bit to logic 0 to disable filter.
2	Remote 2	0	Channel 2 Filter Enable Bit. Set this bit to logic 1 to enable filter for remote channel 2. Set this bit to logic 0 to disable filter.
1	Remote 1	0	Channel 1 Filter Enable Bit. Set this bit to logic 1 to enable filter for remote channel 1. Set this bit to logic 0 to disable filter.
0	Reserved	0	Reserved.

Offset Registers

If desired, an offset value can be applied to the data in any selected temperature channel. Select the offset value using the Custom Offset register (Table 14). The resolution of the custom offset value is 0.125°C, and the MSB is 16°C. The temperature offset is calculated using the following equation:

$$-14.875^{\circ}\text{C} + b[7:0]/8 = \text{Temperature Offset}$$

The resulting offset range is -14.875°C to +17°C. With a default power-on value of 77h, the device has a default temperature offset of 0°C.

Choose the temperature channels to which custom offset is applied using the Custom Offset Enable register (Table 15). The offset value does not affect the value in the highest temperature registers.

Table 14. Custom Offset Register (16h)

BIT	NAME	POR STATE	FUNCTION
7 (MSB)	16°C	0	Digital offset (weighted).
6	8°C	1	Digital offset (weighted).
5	4°C	1	Digital offset (weighted).
4	2°C	1	Digital offset (weighted).
3	1°C	0	Digital offset (weighted).
2	0.5°C	1	Digital offset (weighted).
1	0.25°C	1	Digital offset (weighted).
0	0.125°C	1	Digital offset (weighted).

Table 15. Custom Offset Enable Register (17h)

BIT	NAME	POR STATE	FUNCTION
7 (MSB)	Reserved	0	Reserved.
6	Reserved	0	Reserved.
5	Reserved	0	Reserved.
4	Reserved	0	Reserved.
3	Remote 3	0	Remote 3 Offset Enable Bit. Set to logic 1 to enable offset in the Custom Offset register.
2	Remote 2	0	Remote 2 Offset Enable Bit. Set to logic 1 to enable offset in the Custom Offset register.
1	Remote 1	0	Remote 1 Offset Enable Bit. Set to logic 1 to enable offset in the Custom Offset register.
0	Reserved	0	Reserved.

Register Map

REGISTER	ADDRESS (HEX)	POR VALUE (HEX)	READ/ WRITE	DESCRIPTION
Local Temperature MSB	00	00	R	Read local temperature MSB
Local Temperature LSB	01	00	R	Read local temperature LSB
Remote 1 Temperature MSB	02	00	R	Read channel 1 remote temperature MSB
Remote 1 Temperature LSB	03	00	R	Read channel 1 remote temperature LSB
Remote 2 Temperature MSB	04	00	R	Read channel 2 remote temperature MSB
Remote 2 Temperature LSB	05	00	R	Read channel 2 remote temperature LSB
Remote 3 Temperature MSB	06	00	R	Read channel 3 remote temperature MSB
Remote 3 Temperature LSB	07	00	R	Read channel 3 remote temperature LSB
Highest Temperature MSB	10	00	R	Highest current temperature value MSB. Value in highest temperature register is the greater of all (temperature channel value minus the channel reference temperature value).
Highest Temperature LSB	11	00	R	Highest current temperature value LSB. Value in highest temperature register is the greater of all (temperature channel value minus the channel reference temperature value).
Highest Temperature Enable	12	0F	R/W	Selects which channels are used in determining contents of highest temperature registers.
Configuration	13	10	R/W	Standby, POR, timeout, extended range, comparator/ interrupt mode, one-shot, and filter.
Custom Ideality Factor	14	18	R/W	Select a custom ideality factor for remote-sensing diodes.
Custom Ideality Enable	15	00	R/W	Select the nominal ideality (1.008) or the custom ideality for each remote channel.
Custom Offset	16	77	R/W	Select an offset value for temperature measurement. The device default is -14.875°C, with a programmed value of +14.875°C, which leaves a summed offset of 0°C default from factory/POR.
Custom Offset Enable	17	00	R/W	Enable/disable the custom offset temperature value for each channel.

Register Map (continued)

REGISTER	ADDRESS (HEX)	POR VALUE (HEX)	READ/ WRITE	DESCRIPTION
Filter Enable	18	00	R/W	Enable/disable filter for each remote channel (should be disabled when not in constant conversion mode).
Beta Compensation Enable	19	00	R/W	Enable/disable beta compensation for each remote channel.
Beta Value Channel 1	1A	00	R	Contains the beta compensation value for channel 1.
Beta Value Channel 2	1B	00	R	Contains the beta compensation value for channel 2.
Beta Value Channel 3	1C	00	R	Contains the beta compensation value for channel 3.
Local Thermal High Limit MSB	20	7F	R/W	Read/write local thermal high-temperature threshold limit MSB.
Local Thermal High Limit LSB	21	00	R/W	Read/write local thermal high-temperature threshold limit LSB.
Remote 1 Thermal High Limit MSB	22	7F	R/W	Read/write remote channel 1 thermal high-temperature threshold limit MSB.
Remote 1 Thermal High Limit LSB	23	00	R/W	Read/write remote channel 1 thermal high-temperature threshold limit LSB.
Remote 2 Thermal High Limit MSB	24	7F	R/W	Read/write remote channel 2 thermal high-temperature threshold limit MSB.
Remote 2 Thermal High Limit LSB	25	00	R/W	Read/write remote channel 2 thermal high-temperature threshold limit LSB.
Remote 3 Thermal High Limit MSB	26	7F	R/W	Read/write remote channel 3 thermal high-temperature threshold limit MSB.
Remote 3 Thermal High Limit LSB	27	00	R/W	Read/write remote channel 3 thermal high-temperature threshold limit LSB.
Thermal Low Limit (All Channels) MSB	30	C9	R/W	Read/write thermal low-temperature threshold MSB (shared by all channels).
Thermal Low Limit (All Channels) LSB	31	00	R/W	Read/write thermal low-temperature threshold LSB (shared by all channels).
Thermal Status, High Temperature	32	00	R	Read the high-temperature thermal status for each channel.
Thermal Status, Low Temperature	33	00	R	Read the low-temperature thermal status for each channel.

Register Map (continued)

REGISTER	ADDRESS (HEX)	POR VALUE (HEX)	READ/ WRITE	DESCRIPTION
$\overline{\text{THERM}}$ Mask	34	00	R/W	Mask faults from asserting the $\overline{\text{THERM}}$ pin for each channel.
Temperature Channel Enable	35	0F	R/W	Read/write temperature channel enable.
Diode Fault Status	36	00	R	Read diode fault status for each channel.
Local Reference Temperature MSB	40	00	R/W	MSB of local reference temperature for determining content of the highest temperature registers.
Local Reference Temperature LSB	41	00	R/W	LSB of local reference temperature for determining content of the highest temperature registers.
Remote 1 Reference Temperature MSB	42	00	R/W	MSB of remote channel 1 reference temperature for determining content of the highest temperature registers.
Remote 1 Reference Temperature LSB	43	00	R/W	LSB of remote channel 1 reference temperature for determining content of the highest temperature registers.
Remote 2 Reference Temperature MSB	44	00	R/W	MSB of remote channel 2 reference temperature for determining content of the highest temperature registers.
Remote 2 Reference Temperature LSB	45	00	R/W	LSB of remote channel 2 reference temperature for determining content of the highest temperature registers.
Remote 3 Reference Temperature MSB	46	00	R/W	MSB of remote channel 3 reference temperature for determining content of the highest temperature registers.
Remote 3 Reference Temperature LSB	47	00	R/W	LSB of remote channel 3 reference temperature for determining content of the highest temperature registers.
Manufacturer ID	50	4D	R	Read manufacturer ID.
Revision Code	51	01	R	Read die revision.

Register 00h: Local Temperature MSB

Factory Default Value: 00h

Memory Type: SRAM, Volatile

Memory Access	R	R	R	R	R	R	R	R
00h	D15	D14	D13	D12	D11	D10	D9	D8
°C	Sign	2 ⁶	2 ⁵	2 ⁴	2 ³	2 ²	2 ¹	2 ⁰
	Bit 7			Bit 0				

Register 01h: Local Temperature LSB

Factory Default Value: 00h

Memory Type: SRAM, Volatile

Memory Access	R	R	R	R	R	R	R	R
01h	D7	D6	D5	D4	D3	D2	D1	D0
°C	2 ⁻¹	2 ⁻²	2 ⁻³	2 ⁻⁴	0	0	0	0
	Bit 7				Bit 0			

Register 02h: Remote 1 Temperature MSB

Factory Default Value: 00h

Memory Type: SRAM, Volatile

Memory Access	R	R	R	R	R	R	R	R
02h	D15	D14	D13	D12	D11	D10	D9	D8
°C	Sign	2 ⁶	2 ⁵	2 ⁴	2 ³	2 ²	2 ¹	2 ⁰
	Bit 7				Bit 0			

Register 03h: Remote 1 Temperature LSB

Factory Default Value: 00h

Memory Type: SRAM, Volatile

Memory Access	R	R	R	R	R	R	R	R
03h	D7	D6	D5	D4	D3	D2	D1	D0
°C	2 ⁻¹	2 ⁻²	2 ⁻³	2 ⁻⁴	0	0	0	0
	Bit 7				Bit 0			

Register 04h: Remote 2 Temperature MSB

Factory Default Value: 00h

Memory Type: SRAM, Volatile

Memory Access	R	R	R	R	R	R	R	R
04h	D15	D14	D13	D12	D11	D10	D9	D8
°C	Sign	2 ⁶	2 ⁵	2 ⁴	2 ³	2 ²	2 ¹	2 ⁰
	Bit 7				Bit 0			

Register 05h: Remote 2 Temperature LSB

Factory Default Value: 00h
 Memory Type: SRAM, Volatile

Memory Access	R	R	R	R	R	R	R	R
05h	D7	D6	D5	D4	D3	D2	D1	D0
°C	2 ⁻¹	2 ⁻²	2 ⁻³	2 ⁻⁴	0	0	0	0
	Bit 7				Bit 0			

Register 06h: Remote 3 Temperature MSB

Factory Default Value: 00h
 Memory Type: SRAM, Volatile

Memory Access	R	R	R	R	R	R	R	R
06h	D15	D14	D13	D12	D11	D10	D9	D8
°C	Sign	2 ⁶	2 ⁵	2 ⁴	2 ³	2 ²	2 ¹	2 ⁰
	Bit 7				Bit 0			

Register 07h: Remote 3 Temperature LSB

Factory Default Value: 00h
 Memory Type: SRAM, Volatile

Memory Access	R	R	R	R	R	R	R	R
07h	D7	D6	D5	D4	D3	D2	D1	D0
°C	2 ⁻¹	2 ⁻²	2 ⁻³	2 ⁻⁴	0	0	0	0
	Bit 7				Bit 0			

Register 10h: Highest Temperature MSB

Factory Default Value: 00h
 Memory Type: SRAM, Volatile

Memory Access	R	R	R	R	R	R	R	R
10h	D15	D14	D13	D12	D11	D10	D9	D8
°C	Sign	2 ⁶	2 ⁵	2 ⁴	2 ³	2 ²	2 ¹	2 ⁰
	Bit 7				Bit 0			

Highest current temperature value MSB. Value in the highest temperature register is the greater of all (the temperature channel value minus the channel reference temperature value).

Register 11h: Highest Temperature LSB

Factory Default Value: 00h
 Memory Type: SRAM, Volatile

Memory Access	R	R	R	R	R	R	R	R
11h	D7	D6	D5	D4	D3	D2	D1	D0
°C	2-1	2-2	2-3	2-4	0	0	0	0
	Bit 7				Bit 0			

Highest current temperature value LSB. Value in the highest temperature register will be the greater of all (the temperature channel value minus the channel reference temperature value).

Register 12h: Highest Temperature Enable

Factory Default Value: 0Fh
 Memory Type: SRAM, Volatile

Memory Access	R/W	R/W	R/W	R/W	R/W	R/W	R/W	R/W
12h	Reserved	Reserved	Reserved	Reserved	Remote 3	Remote 2	Remote 1	Local
	Bit 7				Bit 0			

Bit 7	Reserved	Powers on with a value of 0.
Bit 6	Reserved	Powers on with a value of 0.
Bit 5	Reserved	Powers on with a value of 0.
Bit 4	Reserved	Powers on with a value of 0.
Bit 3	Remote 3	Channel 3 Highest Temperature Select Bit. 0 = Do not use channel 3 in determining the highest temperature. 1 = Use channel 3 in determining the highest temperature (default).
Bit 2	Remote 2	Channel 2 Highest Temperature Select Bit. 0 = Do not use channel 2 in determining the highest temperature. 1 = Use channel 2 in determining the highest temperature (default).
Bit 1	Remote 1	Channel 1 Highest Temperature Select Bit. 0 = Do not use channel 1 in determining the highest temperature. 1 = Use channel 1 in determining the highest temperature (default).
Bit 0	Local	Local Channel Highest Temperature Select Bit. 0 = Do not use the local channel in determining the highest temperature. 1 = Use the local channel in determining the highest temperature (default).

Selects which channels are used in determining the contents of the highest temperature register.

Register 13h: Configuration

Factory Default Value: 10h
 Memory Type: SRAM, Volatile

Memory Access	R/W	R/W	R/W	R/W	R/W	R/W	R/W	R/W
13h	STOP	POR	TIMEOUT	INTERRUPT / COMPARATOR	FAULT QUEUE	FAULT QUEUE	EXTRANGE	ONE SHOT
	Bit 7			Bit 0				

Bit 7	STOP	Standby-Mode Control Bit. Setting STOP to 1 disables the ADC and reduces supply current to 2.5µA. 0 = ADC enabled (default). 1 = ADC disabled.
Bit 6	POR	Power-On-Reset Bit. Write this bit to logic 1 to enter the power-on state. This bit is self-clearing. Power-on default value is 0.
Bit 5	TIMEOUT	Timeout Enable Bit. Set to logic 0 to enable SMBus timeout. 0 = SMBus timeout enabled (default). 1 = SMBus timeout disabled.
Bit 4	INTERRUPT/ COMPARATOR	Interrupt/Comparator Mode-Select Bit. 0 = Interrupt mode. 1 = Comparator mode (default).
Bit 3	FAULT QUEUE	Selects the number of consecutive faults needed to assert a thermal fault. 00 = 1 (default) 01 = 2 10 = 4 11 = 6
Bit 2		
Bit 1	EXTRANGE	Extended-Range Enable Bit. 0 = Set maximum reportable temperature value to +127.9375°C (default). 1 = Set maximum reportable temperature value to +191.9375°C.
Bit 0	ONE SHOT	Default state is 0. Write this bit to a 1 to initiate a single cycle of temperature conversions. All other bits in the Configuration register are ignored. After the conversion, the bit automatically resets to 0. ONE SHOT can only be enabled within stop mode.

Register 14h: Customer Ideality Factor

Factory Default Value: 18h
 Memory Type: SRAM, Volatile

Memory Access	R/W	R/W	R/W	R/W	R/W	R/W	R/W	R/W
14h	D7	D6	D5	D4	D3	D2	D1	D0
	See Table 8							
	Bit 7				Bit 0			

Register 15h: Custom Ideality Enable

Factory Default Value: 00h

Memory Type: SRAM, Volatile

Memory Access	N/A	N/A	N/A	N/A	R/W	R/W	R/W	N/A
15h	Reserved	Reserved	Reserved	Reserved	Remote 3	Remote 2	Remote 1	Reserved
	Bit 7				Bit 0			

Bit 7	Reserved	Reserved.
Bit 6	Reserved	Reserved.
Bit 5	Reserved	Reserved.
Bit 4	Reserved	Reserved.
Bit 3	Remote 3	Channel 3 Remote-Diode Ideality Enable Bit. 0 = Sets ideality factor to 1.008 (default). 1 = Sets the ideality factor to the value from the Custom Ideality Factor register (14h).
Bit 2	Remote 2	Channel 2 Remote-Diode Ideality Enable Bit. 0 = Sets ideality factor to 1.008 (default). 1 = Sets the ideality factor to the value from the Custom Ideality Factor register (14h).
Bit 1	Remote 1	Channel 1 Remote-Diode Ideality Enable Bit. 0 = Sets ideality factor to 1.008 (default). 1 = Sets the ideality factor to the value from the Custom Ideality Factor register (14h).
Bit 0	Reserved	Reserved.

Register 16h: Custom Offset

Factory Default Value: 77h

Memory Type: SRAM, Volatile

Memory Access	R/W	R/W	R/W	R/W	R/W	R/W	R/W	R/W
16h	D7	D6	D5	D4	D3	D2	D1	D0
°C	2 ⁴	2 ³	2 ²	2 ¹	2 ⁰	2 ⁻¹	2 ⁻²	2 ⁻³
	Bit 7				Bit 0			

The temperature offset is calculated using the following equation:

$$-14.875^{\circ}\text{C} + b[7:0]/8 = \text{temperature offset}$$

The resulting offset range is -14.875°C to +17°C. With a default power-on value of 77h, the device has a default temperature offset of 0°C.

Register 17h: Custom Offset Enable

Factory Default Value: 00h

Memory Type: SRAM, Volatile

Memory Access	N/A	N/A	N/A	N/A	R/W	R/W	R/W	N/A
17h	Reserved	Reserved	Reserved	Reserved	Remote 3	Remote 2	Remote 1	Reserved
	Bit 7				Bit 0			

Bit 7	Reserved	Reserved.
Bit 6	Reserved	Reserved.
Bit 5	Reserved	Reserved.
Bit 4	Reserved	Reserved.
Bit 3	Remote 3	Remote Channel 3 Offset Enable Bit: 0 = Offset not enabled (default). 1 = Offset enabled.
Bit 2	Remote 2	Remote Channel 2 Offset Enable Bit: 0 = Offset not enabled (default). 1 = Offset enabled.
Bit 1	Remote 1	Remote Channel 1 Offset Enable Bit: 0 = Offset not enabled (default). 1 = Offset enabled.
Bit 0	Reserved	Reserved.

Selects the temperature channels to which the custom offset is applied. The offset value does not affect the value in the highest temperature register.

Register 18h: Filter Enable

Factory Default Value: 00h

Memory Type: SRAM, Volatile

Memory Access	N/A	N/A	N/A	N/A	R/W	R/W	R/W	N/A
1Ch	Reserved	Reserved	Reserved	Reserved	Remote 3	Remote 2	Remote 1	Reserved
	Bit 7				Bit 0			

Bit 7	Reserved	Reserved.
Bit 6	Reserved	Reserved.
Bit 5	Reserved	Reserved.
Bit 4	Reserved	Reserved.
Bit 3	Remote 3	Channel 3 Noise Filter Select Bit. 0 = Noise filtering disabled (default). 1 = Noise filtering enabled.
Bit 2	Remote 2	Channel 2 Noise Filter Select Bit. 0 = Noise filtering disabled (default). 1 = Noise filtering enabled.
Bit 1	Remote 1	Channel 1 Noise Filter Select Bit. 0 = Noise filtering disabled (default). 1 = Noise filtering enabled.
Bit 0	Reserved	Reserved.

Register 19h: Beta Compensation Enable

Factory Default Value: 00h

Memory Type: SRAM, Volatile

Memory Access	N/A	N/A	N/A	N/A	R/W	R/W	R/W	N/A
19h	Reserved	Reserved	Reserved	Reserved	Remote 3	Remote 2	Remote 1	Reserved
	Bit 7				Bit 0			

Bit 7	Reserved	Reserved.
Bit 6	Reserved	Reserved.
Bit 5	Reserved	Reserved.
Bit 4	Reserved	Reserved.
Bit 3	Remote 3	Channel 3 Beta Compensation Enable Bit. 0 = Beta compensation disabled (default). 1 = Beta compensation enabled.
Bit 2	Remote 2	Channel 2 Beta Compensation Enable Bit. 0 = Beta compensation disabled (default). 1 = Beta compensation enabled.
Bit 1	Remote 1	Channel 1 Beta Compensation Enable Bit. 0 = Beta compensation disabled (default). 1 = Beta compensation enabled.
Bit 0	Reserved	Reserved.

Register 1Ah: Beta Value Channel 1

Factory Default Value: 00h

Memory Type: SRAM, Volatile

Memory Access	N/A	N/A	N/A	N/A	R	R	R	R
1Ah	Reserved	Reserved	Reserved	Reserved	Beta Value	Beta Value	Beta Value	Beta Value
	Bit 7				Bit 0			

Bits [7:4]	Reserved	The bits in these locations are reserved.
Bits [3:0]	Beta Value	Reports the amount of beta compensation applied for the remote-diode channel 1 if enabled from the register (see Table 12).

Register 1Bh: Beta Value Channel 2

Factory Default Value: 00h
 Memory Type: SRAM, Volatile

Memory Access	N/A	N/A	N/A	N/A	R	R	R	R
1Bh	Reserved	Reserved	Reserved	Reserved	Beta Value	Beta Value	Beta Value	Beta Value
	Bit 7				Bit 0			

Bits [7:4]	Reserved	The bits in these locations are reserved.
Bits [3:0]	Beta Value	Reports the amount of beta compensation applied for the remote-diode channel 2 if enabled from the Beta Compensation Enable register (see Table 12).

Register 1Ch: Beta Value Channel 3

Factory Default Value: 00h
 Memory Type: SRAM, Volatile

Memory Access	N/A	N/A	N/A	N/A	R	R	R	R
1Ch	Reserved	Reserved	Reserved	Reserved	Beta Value	Beta Value	Beta Value	Beta Value
	Bit 7				Bit 0			

Bits [7:4]	Reserved	The bits in these locations are reserved.
Bits [3:0]	Beta Value	Reports the amount of beta compensation applied for the remote-diode channel 3 if enabled from the Beta Compensation Enable register (see Table 12).

Register 20h: Local Thermal High Limit MSB

Factory Default Value: 7Fh
 Memory Type: SRAM, Volatile

Memory Access	R/W	R/W	R/W	R/W	R/W	R/W	R/W	R/W
20h	D15	D14	D13	D12	D11	D10	D9	D8
°C	Sign	2 ⁶	2 ⁵	2 ⁴	2 ³	2 ²	2 ¹	2 ⁰
	Bit 7				Bit 0			

When the extended format is selected, all limit and reference temperature registers must be written in this format. They are not automatically translated by toggling the extended format bit.

Register 21h: Local Thermal High Limit LSB

Factory Default Value: 00h
 Memory Type: SRAM, Volatile

Memory Access	R/W	R/W	R/W	R/W	R/W	R/W	R/W	R/W
21h	D7	D6	D5	D4	D3	D2	D1	D0
°C	2 ⁻¹	2 ⁻²	2 ⁻³	2 ⁻⁴	0	0	0	0
	Bit 7							Bit 0

When the extended format is selected, all limit and reference temperature registers must be written in this format. They are not automatically translated by toggling the extended format bit.

Register 22h: Remote 1 Thermal High Limit MSB

Factory Default Value: 7Fh
 Memory Type: SRAM, Volatile

Memory Access	R/W	R/W	R/W	R/W	R/W	R/W	R/W	R/W
22h	D15	D14	D13	D12	D11	D10	D9	D8
°C	Sign	2 ⁶	2 ⁵	2 ⁴	2 ³	2 ²	2 ¹	2 ⁰
	Bit 7							Bit 0

When the extended format is selected, all limit and reference temperature registers must be written in this format. They are not automatically translated by toggling the extended format bit.

Register 23h: Remote 1 Thermal High Limit LSB

Factory Default Value: 00h
 Memory Type: SRAM, Volatile

Memory Access	R/W	R/W	R/W	R/W	R/W	R/W	R/W	R/W
23h	D7	D6	D5	D4	D3	D2	D1	D0
°C	2 ⁻¹	2 ⁻²	2 ⁻³	2 ⁻⁴	0	0	0	0
	Bit 7							Bit 0

When the extended format is selected, all limit and reference temperature registers must be written in this format. They are not automatically translated by toggling the extended format bit.

Register 24h: Remote 2 Thermal High Limit MSB

Factory Default Value: 7Fh
 Memory Type: SRAM, Volatile

Memory Access	R/W	R/W	R/W	R/W	R/W	R/W	R/W	R/W
24h	D15	D14	D13	D12	D11	D10	D9	D8
°C	Sign	2 ⁶	2 ⁵	2 ⁴	2 ³	2 ²	2 ¹	2 ⁰
	Bit 7							Bit 0

When the extended format is selected, all limit and reference temperature registers must be written in this format. They are not automatically translated by toggling the extended format bit.

Register 25h: Remote 2 Thermal High Limit LSB

Factory Default Value: 00h
 Memory Type: SRAM, Volatile

Memory Access	R/W	R/W	R/W	R/W	R/W	R/W	R/W	R/W
25h	D7	D6	D5	D4	D3	D2	D1	D0
°C	2 ⁻¹	2 ⁻²	2 ⁻³	2 ⁻⁴	0	0	0	0
	Bit 7							Bit 0

When the extended format is selected, all limit and reference temperature registers must be written in this format. They are not automatically translated by toggling the extended format bit.

Register 26h: Remote 3 Thermal High Limit MSB

Factory Default Value: 7Fh
 Memory Type: SRAM, Volatile

Memory Access	R/W	R/W	R/W	R/W	R/W	R/W	R/W	R/W
26h	D15	D14	D13	D12	D11	D10	D9	D8
°C	Sign	2 ⁶	2 ⁵	2 ⁴	2 ³	2 ²	2 ¹	2 ⁰
	Bit 7							Bit 0

When the extended format is selected, all limit and reference temperature registers must be written in this format. They are not automatically translated by toggling the extended format bit.

Register 27h: Remote 3 Thermal High Limit LSB

Factory Default Value: 00h
 Memory Type: SRAM, Volatile

Memory Access	R/W	R/W	R/W	R/W	R/W	R/W	R/W	R/W
27h	D7	D6	D5	D4	D3	D2	D1	D0
°C	2 ⁻¹	2 ⁻²	2 ⁻³	2 ⁻⁴	0	0	0	0
	Bit 7							Bit 0

When the extended format is selected, all limit and reference temperature registers must be written in this format. They are not automatically translated by toggling the extended format bit.

Register 30h: Thermal Low Limit (All Channels) MSB

Factory Default Value: C9h
 Memory Type: SRAM, Volatile

Memory Access	R/W	R/W	R/W	R/W	R/W	R/W	R/W	R/W
30h	D15	D14	D13	D12	D11	D10	D9	D8
°C	Sign	2 ⁶	2 ⁵	2 ⁴	2 ³	2 ²	2 ¹	2 ⁰
	Bit 7							Bit 0

When the extended format is selected, all limit and reference temperature registers must be written in this format. They are not automatically translated by toggling the extended format bit.

Register 31h: Thermal Low Limit (All Channels) LSB

Factory Default Value: 00h
 Memory Type: SRAM, Volatile

Memory Access	R/W	R/W	R/W	R/W	R/W	R/W	R/W	R/W
31h	D7	D6	D5	D4	D3	D2	D1	D0
°C	2 ⁻¹	2 ⁻²	2 ⁻³	2 ⁻⁴	0	0	0	0
	Bit 7							Bit 0

When the extended format is selected, all limit and reference temperature registers must be written in this format. They are not automatically translated by toggling the extended format bit.

Register 32h: Thermal Status, High Temperature

Factory Default Value: 00h

Memory Type: SRAM, Volatile

Memory Access	N/A	N/A	N/A	N/A	R	R	R	R
32h	Reserved	Reserved	Reserved	Reserved	Remote 3	Remote 2	Remote 1	Local
	Bit 7				Bit 0			

Bits [7:4]	Reserved	Reserved.
Bit 3	Remote 3	Channel 3 Remote-Diode High Thermal Bit. 0 = Default value. 1 = Indicates that the temperature sensed on the channel 3 remote diode exceeds the selected temperature threshold limit stored in the channel 3 thermal high limit register.
Bit 2	Remote 2	Channel 2 Remote-Diode High Thermal Bit. 0 = Default value. 1 = Indicates that the temperature sensed on the channel 2 remote diode exceeds the selected temperature threshold limit stored in the channel 2 thermal high limit register.
Bit 1	Remote 1	Channel 1 Remote-Diode High Thermal Bit. 0 = Default value. 1 = Indicates that the temperature sensed on the channel 1 remote diode exceeds the selected temperature threshold limit stored in the channel 1 thermal high limit register.
Bit 0	Local	Local High Thermal Bit. 0 = Default value. 1 = Indicates that the temperature sensed on the local channel exceeds the selected temperature threshold limit stored in the local thermal high limit register.

Register 33h: Thermal Status, Low Temperature

Factory Default Value: 00h

Memory Type: SRAM, Volatile

Memory Access	N/A	N/A	N/A	N/A	R	R	R	R
33h	Reserved	Reserved	Reserved	Reserved	Remote 3	Remote 2	Remote 1	Local
	Bit 7				Bit 0			

Bits [7:4]	Reserved	Reserved.
Bit 3	Remote 3	Channel 3 Remote-Diode Low Thermal Bit. 0 = Default value. 1 = Indicates that the temperature sensed on the channel 3 remote diode is less than the selected temperature threshold limit stored in the thermal low limit register.
Bit 2	Remote 2	Channel 2 Remote-Diode Low Thermal Bit. 0 = Default value. 1 = Indicates that the temperature sensed on the channel 2 remote diode is less than the selected temperature threshold limit stored in the thermal low limit register.
Bit 1	Remote 1	Channel 1 Remote-Diode Low Thermal Bit. 0 = Default value. 1 = Indicates that the temperature sensed on the channel 1 remote diode is less than the selected temperature threshold limit stored in the thermal low limit register.
Bit 0	Local	Local Low Thermal Bit. 0 = Default value. 1 = Indicates that the temperature sensed on the local channel is less than the selected temperature threshold limit stored in the thermal low limit register.

Register 34h: $\overline{\text{THERM}}$ Mask

Factory Default Value: 00h

Memory Type: SRAM, Volatile

Memory Access	N/A	N/A	N/A	N/A	R/W	R/W	R/W	R/W
34h	Reserved	Reserved	Reserved	Reserved	Remote 3	Remote 2	Remote 1	Local
	Bit 7				Bit 0			

Bits [7:4]	Reserved	Reserved.
Bit 3	Remote 3	Channel 3 Thermal Mask Bit. 0 = Default value. 1 = Masks the assertion of the $\overline{\text{THERM}}$ pin when a thermal fault on channel 3 occurs.
Bit 2	Remote 2	Channel 2 Thermal Mask Bit. 0 = Default value. 1 = Masks the assertion of the $\overline{\text{THERM}}$ pin when a thermal fault on channel 2 occurs.
Bit 1	Remote 1	Channel 1 Thermal Mask Bit. 0 = Default value. 1 = Masks the assertion of the $\overline{\text{THERM}}$ pin when a thermal fault on channel 1 occurs.
Bit 0	Local	Local Thermal Mask Bit. 0 = Default value. 1 = Masks the assertion of the $\overline{\text{THERM}}$ pin when a thermal fault on the local channel occurs.

Register 35h: Temperature Channel Enable

Factory Default Value: 0Fh

Memory Type: SRAM, Volatile

Memory Access	N/A	N/A	N/A	N/A	R/W	R/W	R/W	R/W
35h	Reserved	Reserved	Reserved	Reserved	Enable 3	Enable 2	Enable 1	Enable Local
	Bit 7				Bit 0			

Bits [7:4]	Reserved	Reserved.
Bit 3	Remote 3	Channel 3 Enable Bit. 0 = Channel 3 is not enabled and is skipped during the temperature conversion cycle. Diode fault detection is not performed on this channel. 1 = Temperature conversions and diode fault detection are enabled for channel 3 (default).
Bit 2	Remote 2	Channel 2 Enable Bit. 0 = Channel 2 is not enabled is skipped during the temperature conversion cycle. Diode fault detection is not performed on this channel. 1 = Temperature conversions and diode fault detection are enabled for channel 2 (default).
Bit 1	Remote 1	Channel 1 Enable Bit. 0 = Channel 1 is not enabled, and is skipped during the temperature conversion cycle. Diode fault detection is not performed on this channel. 1 = Temperature conversions and diode fault detection are enabled for channel 1 (default).
Bit 0	Local	Local Enable Bit. 0 = The Local Channel is not enabled, and will be skipped during the temperature conversion cycle. 1 = Temperature conversions are enabled for the local channel (default).

Register 36h: Diode Fault Status

Factory Default Value: 00h
 Memory Type: SRAM, Volatile

Memory Access	N/A	N/A	N/A	N/A	R/W	R/W	R/W	N/A
36h	Reserved	Reserved	Reserved	Reserved	Remote 3	Remote 2	Remote 1	Reserved
	Bit 7				Bit 0			

Bits [7:4]	Reserved	Reserved.
Bit 3	Remote 3	Channel 3 Diode Fault Bit. 0 = Default value. 1 = Indicates an open or short on the channel 3 remote-diode connection.
Bit 2	Remote 2	Channel 2 Diode Fault Bit. 0 = Default value. 1 = Indicates an open or short on the channel 2 remote-diode connection.
Bit 1	Remote 1	Channel 1 Diode Fault Bit. 0 = Default value. 1 = Indicates an open or short on the channel 1 remote-diode connection.
Bit 0	Reserved	Reserved. Always 0.

Register 40h: Local Reference Temperature MSB

Factory Default Value: 00h
 Memory Type: SRAM, Volatile

Memory Access	R/W	R/W	R/W	R/W	R/W	R/W	R/W	R/W
40h	D15	D14	D13	D12	D11	D10	D9	D8
°C	Sign	2 ⁶	2 ⁵	2 ⁴	2 ³	2 ²	2 ¹	2 ⁰
	Bit 7				Bit 0			

MSB of the local reference temperature (used for determining the content of the highest temperature registers).
 When the extended format is selected, all limit and reference temperature registers must be written in this format. They are not automatically translated by toggling the extended format bit.

Register 41h: Local Reference Temperature LSB

Factory Default Value: 00h
 Memory Type: SRAM, Volatile

Memory Access	R/W	R/W	R/W	R/W	R/W	R/W	R/W	R/W
41h	D7	D6	D5	D4	D3	D2	D1	D0
°C	2 ⁻¹	2 ⁻²	2 ⁻³	2 ⁻⁴	0	0	0	0
	Bit 7							Bit 0

LSB of the local reference temperature (used for determining the content of the highest temperature registers).
 When the extended format is selected, all limit and reference temperature registers must be written in this format. They are not automatically translated by toggling the extended format bit.

Register 42h: Remote 1 Reference Temperature MSB

Factory Default Value: 00h
 Memory Type: SRAM, Volatile

Memory Access	R/W	R/W	R/W	R/W	R/W	R/W	R/W	R/W
42h	D15	D14	D13	D12	D11	D10	D9	D8
°C	Sign	2 ⁶	2 ⁵	2 ⁴	2 ³	2 ²	2 ¹	2 ⁰
	Bit 7							Bit 0

MSB of the channel 1 reference temperature (used for determining the content of the highest temperature registers).
 When the extended format is selected, all limit and reference temperature registers must be written in this format. They are not automatically translated by toggling the extended format bit.

Register 43h: Remote 1 Reference Temperature LSB

Factory Default Value: 00h
 Memory Type: SRAM, Volatile

Memory Access	R/W	R/W	R/W	R/W	R/W	R/W	R/W	R/W
43h	D7	D6	D5	D4	D3	D2	D1	D0
°C	2 ⁻¹	2 ⁻²	2 ⁻³	2 ⁻⁴	0	0	0	0
	Bit 7							Bit 0

LSB of the channel 1 reference temperature (used for determining the content of the highest temperature registers).
 When the extended format is selected, all limit and reference temperature registers must be written in this format. They are not automatically translated by toggling the extended format bit.

Register 44h: Remote 2 Reference Temperature MSB

Factory Default Value: 00h
 Memory Type: SRAM, Volatile

Memory Access	R/W	R/W	R/W	R/W	R/W	R/W	R/W	R/W
44h	D15	D14	D13	D12	D11	D10	D9	D8
°C	Sign	2 ⁶	2 ⁵	2 ⁴	2 ³	2 ²	2 ¹	2 ⁰
	Bit 7							Bit 0

MSB of the channel 2 reference temperature (used for determining the content of the highest temperature registers).
 When the extended format is selected, all limit and reference temperature registers must be written in this format. They are not automatically translated by toggling the extended format bit.

Register 45h: Remote 2 Reference Temperature LSB

Factory Default Value: 00h
 Memory Type: SRAM, Volatile

Memory Access	R/W	R/W	R/W	R/W	R/W	R/W	R/W	R/W
45h	D7	D6	D5	D4	D3	D2	D1	D0
°C	2 ⁻¹	2 ⁻²	2 ⁻³	2 ⁻⁴	0	0	0	0
	Bit 7							Bit 0

LSB of the channel 2 reference temperature (used for determining the content of the highest temperature registers).
 When the extended format is selected, all limit and reference temperature registers must be written in this format. They are not automatically translated by toggling the extended format bit.

Register 46h: Remote 3 Reference Temperature MSB

Factory Default Value: 00h
 Memory Type: SRAM, Volatile

Memory Access	R/W	R/W	R/W	R/W	R/W	R/W	R/W	R/W
46h	D15	D14	D13	D12	D11	D10	D9	D8
°C	Sign	2 ⁶	2 ⁵	2 ⁴	2 ³	2 ²	2 ¹	2 ⁰
	Bit 7							Bit 0

MSB of the channel 3 reference temperature (used for determining the content of the highest temperature registers).
 When the extended format is selected, all limit and reference temperature registers must be written in this format. They are not automatically translated by toggling the extended format bit.

Register 47h: Remote 3 Reference Temperature LSB

Factory Default Value: 00h
 Memory Type: SRAM, Volatile

Memory Access	R/W	R/W	R/W	R/W	R/W	R/W	R/W	R/W
47h	D7	D6	D5	D4	D3	D2	D1	D0
°C	2-1	2-2	2-3	2-4	0	0	0	0
	Bit 7							Bit 0

LSB of the channel 3 reference temperature (used for determining the content of the highest temperature registers).
 When the extended format is selected, all limit and reference temperature registers must be written in this format. They are not automatically translated by toggling the extended format bit.

Register 50h: Manufacturer ID

Factory Default Value: 4Dh
 Memory Type: SRAM, Volatile

Memory Access	R/W	R/W	R/W	R/W	R/W	R/W	R/W	R/W
50h	D7	D6	D5	D4	D3	D2	D1	D0
	0	1	0	0	1	1	0	1
	Bit 7							Bit 0

Contains the code for the Manufacturer’s ID for the device.

Register 51h: Revision Code

Factory Default Value: 01h
 Memory Type: SRAM, Volatile

Memory Access	R/W	R/W	R/W	R/W	R/W	R/W	R/W	R/W
51h	D7	D6	D5	D4	D3	D2	D1	D0
	0	0	0	0	0	0	0	0
	Bit 7							Bit 0

Contains the revision code for the device.

Applications Information

Remote-Diode Selection

The device directly measures the die temperature of CPUs and other ICs that have on-chip temperature-sensing diodes (see the [Typical Application Circuits](#)), or it can measure the temperature of a discrete diode-connected transistor.

Discrete Remote Diodes

When the remote-sensing diode is a discrete transistor, its collector and base must be connected together; PNP or npn discrete transistors can be used. [Table 16](#) lists examples of discrete transistors that are appropriate for use with this device. The transistor must be a small-signal type with a relatively high forward voltage; otherwise, the A/D input voltage range can be violated. The forward voltage at the highest expected temperature must be greater than 0.25V at 10 μ A; at the lowest expected temperature, the forward voltage must be less than 0.95V at 100 μ A. Large power transistors must not be used. Also, ensure that the base resistance is less than 100 Ω . Tight specifications for forward-current gain (e.g., $50 < \beta < 150$) indicate that the manufacturer has good process controls and that the devices have consistent V_{BE} characteristics. Manufacturers of discrete transistors do not normally specify or guarantee ideality factor. This normally is not a problem since good-quality discrete transistors tend to have ideality factors that fall within a relatively narrow range. Variations in remote temperature readings of less than $\pm 2^{\circ}\text{C}$ with a variety of discrete transistors have been observed. However, it is good design practice to verify good consistency of temperature readings with several discrete transistors from any supplier under consideration.

Unused Diode Channels

If one or more of the remote-diode channels is not needed, disconnect the DXP_ and DXN_ inputs for that channel, or connect the DXP_ to the corresponding DXN_. The status register indicates a diode “fault” for this channel and the channel is ignored during the temperature-measurement sequence. It is also good practice to mask any unused channels immediately upon power-up by setting the appropriate bits in the THERM Mask register. This prevents unused channels from causing THERM to assert.

Table 16. Remote Sensors Transistor Suppliers

SUPPLIER	PNP MODEL NUMBER
Central Semiconductor Corp. (USA)	CMPT3906 2N3906
Fairchild Semiconductor (USA)	MMBT3906 2N3906
Infineon (Germany)	SMBT3906
ON Semiconductor (USA)	MMBT3906 2N3906
ROHM Semiconductor (USA)	SST3906
Samsung (Korea)	KST3906-TF
Siemens (Germany)	SMBT3906
Zetex (England)	FMMT3906CT-ND

Thermal Mass and Self-Heating

When sensing local temperature, the device measures the temperature of the PCB to which it is soldered.

The leads provide a good thermal path between the PCB traces and the die. As with all IC temperature sensors, thermal conductivity between the die and the ambient air is poor by comparison, making air-temperature measurements impractical. Since the thermal mass of the PCB is far greater than that of the device, the device follows temperature changes on the PCB with little or no perceivable delay. When measuring the temperature of a CPU, or other IC with an on-chip sense junction, thermal mass has virtually no effect; the measured temperature of the junction tracks the actual temperature within a conversion cycle. When measuring temperature with discrete remote transistors, the best thermal-response times are obtained with transistors in small packages (i.e., SOT23 or SC70). Take care to account for thermal gradients between the heat source and the sensor, and ensure that stray air currents across the sensor package do not interfere with measurement accuracy. Self-heating does not significantly affect measurement accuracy. Remote-sensor self-heating due to the diode current source is negligible.

ADC Noise Filtering

The integrating ADC has good noise rejection for low-frequency signals, such as power-supply hum. In environments with significant high-frequency EMI, connect an external 100pF capacitor between DXP_ and DXN_. Larger capacitor values can be used for added filtering; however, this can introduce errors due to the rise time of the switched current source. Noise can be minimized with careful PCB layout, as discussed in the *PCB Layout* section.

Slave Address

Slave addresses can be selected by connecting ADD, as shown in [Table 17](#).

PCB Layout

Follow the guidelines below to reduce the measurement error when measuring remote temperature:

- 1) Place the device as close as possible to the thermal diode. In noisy environments, such as a computer motherboard, this distance is typically 10cm to 20cm. This length can be increased if the worst noise sources are avoided. Noise sources include displays, clock generators, memory buses, and PCI buses.
- 2) Do not route the DXP_ and DXN_ traces across fast digital signals, which can easily introduce +30°C error, even with good filtering.

- 3) Route the DXP_ and DXN_ traces in parallel and in close proximity to each other. Each parallel pair of traces should go to a thermal diode. Route these traces away from any higher voltage traces, such as +12V_{DC}. Leakage currents from PCB contamination must be dealt with carefully since a 20MΩ leakage path from DXP_ to ground causes approximately +1°C error. If high-voltage traces are unavoidable, connect guard traces to GND on either side of the DXP_ - DXN_ traces ([Figure 5](#)).

- 4) Route through as few vias and crossunders as possible to minimize copper/solder thermocouple effects.

Use wide traces when possible (5-mil to 10-mil traces are typical).

Twisted-Pair and Shielded Cables

Use a twisted-pair cable to connect the remote sensor for remote-sensor distances longer than 20cm or in very noisy environments. Twisted-pair cable lengths can be between 2m and 4m before noise introduces excessive errors. For longer distances, the best solution is a shielded twisted pair, such as those used for audio microphones.

For example, Belden No. 8451 works well for distances up to 100ft in a noisy environment. At the device, connect the twisted-pair cables to DXP_ and DXN_ and the shielded cable to GND. Leave the shielded cable unconnected at the remote sensor. For very long cable runs, the cable’s parasitic capacitance often provides noise filtering; therefore, the 100pF capacitor can often be removed, or reduced in value.

Table 17. Slave Address Selection

RESISTOR BETWEEN ADD AND GND	SLAVE ADDRESS (HEX)
15kΩ to 39kΩ	0x9E
9.31kΩ	0x9C
6.81kΩ	0x9A
4.75kΩ	0x98
3.01kΩ	0x3E
1.69kΩ	0x3C
750Ω	0x3A
0 (< 250Ω)	0x38

Note: Resistor value tolerance must be ±5% of the listed values.

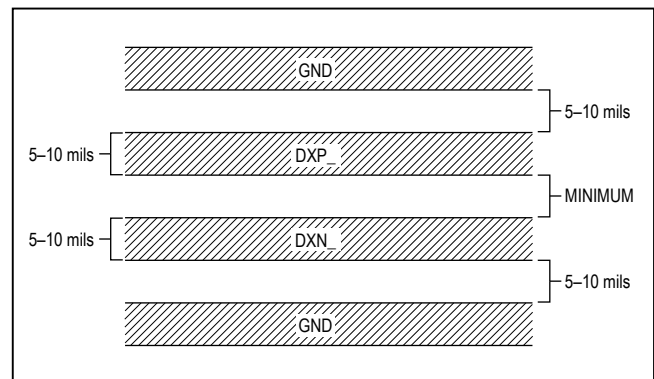

Figure 5. Recommended DXP_ - DXN_ PCB Traces
(The two outer-guard traces are recommended if high-voltage traces are near the DXN_ and DXP_ traces)

Ordering Information

PART	TEMP RANGE	PIN-PACKAGE
MAX31730AUB+	-40°C to +125°C	10 μ MAX
MAX31730AUB+T	-40°C to +125°C	10 μ MAX
MAX31730ATC+	-40°C to +125°C	12 TDFN-EP*
MAX31730ATC+T	-40°C to +125°C	12 TDFN-EP*

+Denotes a lead(Pb)-free/RoHS-compliant package.

T = Tape and reel.

*EP = Exposed pad.

Package Information

For the latest package outline information and land patterns (footprints), go to www.maximintegrated.com/packages. Note that a "+", "#", or "-" in the package code indicates RoHS status only. Package drawings may show a different suffix character, but the drawing pertains to the package regardless of RoHS status.

PACKAGE TYPE	PACKAGE CODE	OUTLINE NO.	LAND PATTERN NO.
10 μ MAX	U10+2	21-0061	90-0330
12 TDFN-EP	TD1233+1C	21-0664	90-0397

Chip Information

PROCESS: CMOS

Revision History

REVISION NUMBER	REVISION DATE	DESCRIPTION	PAGES CHANGED
0	3/14	Initial release	—
1	12/14	Updated <i>General Description</i> and <i>Benefits and Features</i> sections	1
2	4/15	Removed future product designation from <i>Ordering Information</i>	47

For pricing, delivery, and ordering information, please contact Maxim Direct at 1-888-629-4642, or visit Maxim Integrated's website at www.maximintegrated.com.

Maxim Integrated cannot assume responsibility for use of any circuitry other than circuitry entirely embodied in a Maxim Integrated product. No circuit patent licenses are implied. Maxim Integrated reserves the right to change the circuitry and specifications without notice at any time. The parametric values (min and max limits) shown in the Electrical Characteristics table are guaranteed. Other parametric values quoted in this data sheet are provided for guidance.

X-ON Electronics

Largest Supplier of Electrical and Electronic Components

Click to view similar products for [Board Mount Temperature Sensors](#) category:

Click to view products by [Maxim](#) manufacturer:

Other Similar products are found below :

[5962-8757102XA](#) [66F115](#) [EMC1063-1-ACZL-TR](#) [NCT218FCT2G](#) [O53GAB175A-160Y](#) [3610085020002](#) [389049M9527](#) [MIKROE-912](#)
[ADM1023ARQZ-REEL](#) [ADM1032ARMZ-1RL](#) [AT30TS74-U1FMBB-T](#) [AT30TS74-U1FMAB-T](#) [AT30TS74-U1FMCB-T](#) [AT30TS74-](#)
[U1FMDB-T](#) [ADT7483AARQZ-RL](#) [ADT7481ARMZ-REEL](#) [ADT7463ARQZ-REEL](#) [MCP98243T-BE/MC](#) [66L080-0226](#) [5962-8757103XA](#)
[S-58LM20A-I4T1U](#) [NCT375MNR2G](#) [LM84CIMQA](#) [CAT34TS00VP2GT4A](#) [NCT80DBR2G](#) [SEN-16304](#) [GX21M15](#) [GX122](#) [NST175H-](#)
[QSPR](#) [TC6501P065VCTTR](#) [AT-1U](#) [MCP9700AT-E/LT](#) [MCP9701-E/TO](#) [MCP9803-M/MS](#) [MCP9701A-E/TO](#) [LM57FEPWQ1](#) [LM57FPW](#)
[LM57FSPWQ1](#) [60-41123102-0150.0010](#) [60-43123102-0150.0010](#) [60-53123102-0150.0010](#) [MLX90615SSG-DAA-000-TU](#) [TMP303CDRLR](#)
[TC6501P055VCTTR](#) [TC6503P005VCTTR](#) [ADT7311WTRZ-RL](#) [ADT7311WTRZ-RL7](#) [ADT7473ARQZ-REEL](#) [LM335AM](#)
[LM335AM/NOPB](#)