

General Description

The MAX31840 evaluation kit (EV kit) demonstrates the MAX31840 LED driver IC used for dimmable 12V MR16 as well as AR111 and other 12V lighting applications. The EV kit is configured in a boost topology that provides an output power of up to 13W for up to 35V LED forward voltage. The IC is designed for the boost architecture to address 35W and 50W MR16 LED replacement bulbs. The EV kit's typical efficiency 90% at 12V AC and features a power-factor correction of 0.9 (typ).

The EV kit is a fully assembled and tested surface-mount PCB designed and optimized to accommodate an MR16 application form factor. The EV kit is dimmable with most electronic transformers and trailing-edge dimmer combinations. The EV kit includes bleeder and constant power circuits for enhanced electronic transformer performance.

Features

- Input Voltage Ranges
 - 9V AC to 13.2V AC from AC Source
 - 6.5V to 13.8V DC or Output of Electronic Transformers
- Drives Up to 35V LED Forward Voltage
- 36V Overvoltage Protection
- Up to 13W Output Power
- Demonstrates IC Power-Factor Correction
- Proven PCB Layout
- Fully Assembled and Tested

Ordering Information appears at end of data sheet.

Quick Start

Required Equipment

- MAX31840 EV kit
- 12V AC or DC supply, or a 12V electronic transformer
- Trailing edge dimmer
- Current probe to measure the LED current

Procedure

The EV kit is fully assembled and tested. Follow the steps below to verify board operation. **Caution:** Do not turn on the power supply until all connections are completed.

Test with AC or DC Source

- 1) Connect the AC or DC source to the AC1 and AC2 test-point pads.
- 2) Enable the power supply.
- 3) Measure the LED current using the current probe.

Test with Electronic Transformer Plus Dimmer

- 1) Connect the output of a trailing edge dimmer to the input of electronic transformer.
- 2) Connect the output of the electronic transformer to the AC1 and AC2 test-point pads.
- 3) Connect the input of the dimmer to power outlet.
- 4) Turn on the dimmer.
- 5) Measure the LED current using the current probe.
- 6) Adjust dimmer setting to change brightness on the LED.

Detailed Description of Hardware

The MAX31840 EV kit demonstrates the MAX31840 MR16 LED driver. The MAX31840 is an average current-mode control LED driver IC for boost topology in low-voltage SSL applications. The MAX31840 incorporates a proprietary circuit that enables deep dimming and an integrated bleeder to improve compatibility with a broad range of electronic transformers.

The EV kit circuit is configured in boost topology that operates at the IC's fixed 700kHz switching frequency and provides up to 13W of output power for HBLEDs connected at the LED+ and LED- test-point holes. The EV kit circuit operates from a 6.5V to 13.8V AC or 9V to 13.2V DC supply or from electronic transformers. The EV kit is designed on a proven 2oz copper, two layer, small PCB footprint design that fits in a MR16 application form factor.

The IC regulates the average voltage on CS to 200mV. The average input current is set by the current-sense resistor R4. The average current is:

$$I_{AV} = \frac{0.2}{R_4}$$

where 0.2 is the voltage at the IC's CS pin and R4 is in ohms. The R4 on the EV kit is 0.2Ω and the average current is about 1000mA.

The CS pin monitors the current through the sense resistor R4. When V_{CS} falls below 180mV, the bleeder FET is turned on to maintain the minimum load requirement and keep the electronic transformer on. Current through the bleeder FET is set by R2:

$$I_{BLEEDER} = \frac{0.5}{R_2}$$

where 0.5 is the voltage at the BSRC pin and R2 is in ohms. The R2 on the EV kit is 0.5Ω, and $I_{BLEEDER}$ is about 1000mA. R5 and R7 are used to provide protection to the bleeder FET against high voltage at the output of the rectifier.

With 0.2Ω R2 and 0.5Ω R5, the power consumption of the system is approximately $1000\text{mA} \times 12\text{V}_{IN} = 12\text{W}$ (average current times input RMS voltage). This is equivalent to 50W halogen bulb. For 35W equivalent application, use 0.33Ω for R4 and 0.82Ω for R2.

R3 and C5 are lowpass filters to eliminate the high-frequency components and glitches on the output signal of the electronic transformer.

The electronic transformer constantly outputs short pulses and checks the existence of any connected devices. If the load is too small, the electronic transformer does not turn on. The D1 diode provides a direct path for the electronic transformer to turn on the internal LDO of the MAX31840. The bleeder FET can be turned on only after LDO is enabled.

Maximum LED+ Voltage

The IC features an internal 36V overvoltage protection at the IN pin to protect the internal switching MOSFET from damage if the LED string is open or if the voltage on the LED string is too high.

Electronic Transformer Compatibility

The MR16 board was tested with 8 LEDs for electronic transformer compatibility and also with the appropriate dimmers. See [Table 1](#) for the results with the different transformer models tested.

Table 1. Electronic Transformers Tested

MANUFACTURER (MODEL NAME)	RATED INPUT VOLTAGE AND POWER	LED OUTPUT VOLTAGE (V)	LED OUTPUT CURRENT (mA)
KEYSTONE			
KTET-75-1-SCP-DIM-HV-AL	120V, 75W	29.3	255
PHILIPS			
ET-E 60 220-240	220V to 240V 20W to 60W	31.7	226
ET-S 60 220-240	220V to 240V 20W to 60W	31.5	211
LUXMAN			
ETH 60.202	220V to 240V 20W to 60W	32.5	182
HATCH			
RS12-60M	120V, 60W	28.7	276
BL TECHNOLOGIES			
CV-10/75-12	120V, 75W	29	286
LIGHTTECH			
LET 75	120V, 75W	29.1	234
LET 60	120V, 60W	29.1	221
LET 75 BF	120V, 75W	29.3	221
RJ US			
HD75-120	120V,75W	29.6	235
KS ELECTRONIC TRANSFORMER			
—	110V, 50W	29.7	234

Component Suppliers

SUPPLIER	WEBSITE
BOURNS	www.bourns.com
DIODES INCORPORATED	www.diodes.com
INTERNATIONAL RECTIFIER	www.infineon.com
MICRO COMMERCIAL COMPONENTS	www.mccsemi.com
MURATA	www.murata.com
NICHICON	www.nichicon.co.jp
PANASONIC	na.industrial.panasonic.com
ROHM SEMICONDUCTOR	www.rohm.com
STACKPOLE ELECTRONICS INC	www.seielect.com
TDK	www.component.tdk.com
TOSHIBA	toshiba.semicon-storage.com
YOGEO	www.yageo.com

Note: Indicate that you are using the MAX31840 when contacting these component suppliers.

Ordering Information

PART	TYPE
MAX31840EVKIT#	EV Kit

#Denotes RoHS compliant.

MAX31840 EV Kit Bill of Materials

ITEM	REF_DES	DNI/DNP	QTY	MFG PART #	MANUFACTURER	VALUE	DESCRIPTION
1	AC1, AC2	—	2	N/A	N/A	TP_SMD_3MM	TEST POINT; PAD DIA 3MM; SMD
2	C1	—	1	GRM155R71E472KA01	MURATA	4700PF	CAPACITOR; SMT (0402); CERAMIC CHIP; 4700PF; 25V; TOL = 10%; TG = -55°C TO +125°C; TC = X7R;
3	C2	—	1	CGA2B3X7R1H104K; C1005X7R1H104K050BB; GRM155R71H104KE14	TDK; MURATA	0.1µF	CAPACITOR; SMT (0402); CERAMIC CHIP; 0.1µF; 50V; TOL = 10%; TG = -55°C TO +125°C; TC = X7R
4	C3	—	1	UMK107BJ105KA-T; C1608X5R1H105K080AB; CL10A105KB8NNN; GRM188R61H105KAAL	TAIYO YUDEN; TDK; SAMSUNG; MURATA	1µF	CAPACITOR; SMT (0603); CERAMIC CHIP; 1µF; 50V; TOL = 10%; MODEL = _MK SERIES; TG = -55°C TO +85°C
5	C4	—	1	UPW1H151MPD1TD	NICHICON	150µF	CAPACITOR; THROUGH HOLE-RADIAL LEAD; ALUMINUM-ELECTROLYTIC; 150µF; 50V; TOL = 20%
6	C5	—	1	GRM155R71C224KA12	MURATA	0.22µF	CAPACITOR; SMT (0402); CERAMIC; 0.22µF; 16V; TOL = 10%; MODEL = GRM SERIES; TG = -55°C TO +125°C; TC = X7R
7	D1	—	1	1SS417	TOSHIBA	1SS417	DIODE; SCH; SMT (SOD-923); PIV = 45V; IF = 0.1A
8	D2	—	1	B360A-13-F	DIODES INCORPORATED	B360A-13-F	DIODE; SCH; SMA; PIV = 60V; IF = 3A
9	L1	—	1	VLS6045EX-101M	TDK	100UH	INDUCTOR; SMT; WOUND FERRITE; 100µH; TOL = ±20%; 0.9A;
10	Q1	—	1	IRLML2502PBF	INTERNATIONAL RECTIFIER	IRLML2502PBF	TRAN; N-CHANNEL MOSFET; NCH; SOT-23; PD-(0.8W); I-(4.2A); V-(20V)
11	R1	—	1	RNCP0603FTD100R	STACKPOLE ELECTRONICS INC	100	RESISTOR; 0603; 100Ω; 1%; 100PPM; 0.125W; THIN FILM
12	R2	—	1	CSR1206FTR500	STACKPOLE ELECTRONICS INC.	0.5	RESISTOR; 1206; 0.5Ω; 1%; 100PPM; 0.5W; THICK FILM
13	R3	—	1	ERJ-2RKF5600X	PANASONIC	560	RESISTOR; 0402; 560Ω; 1%; 100PPM; 0.0625W; THICK FILM
14	R4	—	1	RL0805FR-7W0R2L	YAGEO	0.2	RESISTOR; 0805; 0.2Ω; 1%; 600PPM; 0.25W; THICK FILM
15	R5, R7	—	2	ERJ14YJ3R9	PANASONIC	3.9	RESISTOR; 1210; 3.9Ω; 5%; -400+150PPM; 0.5W; THICK FILM
16	U1	—	1	MAX31840	MAXIM	MAX31840	EVKIT PART-IC; TDFN8-EP; MR16 LED DRIVER WITH INTEGRATED CONTROL MOSFET AND DEEP DIMMING; PACKAGE CODE: T833+3; PACKAGE OUTLINE: 21-0137P
17	U2	—	1	MB16S	MICRO COMMERCIAL COMPONENTS	MB16S	DIODE; SCH; TO-269AA; PIV = 60V; IF = 1A
18	PCB	—	1	MAX31840	MAXIM	PCB	PCB:MAX31840
19	LED+, LED-	DNP	0	5004	KEYSTONE	N/A	TEST POINT; PIN DIA = 0.1IN; TOTAL LENGTH = 0.3IN; BOARD HOLE = 0.04IN; YELLOW; PHOSPHOR BRONZE WIRE SILVER PLATE FINISH;
TOTAL			20				

NOTE: DNI--> DO NOT INSTALL(PACKOUT) ; DNP--> DO NOT PROCURE

MAX31840 EV Kit Schematic

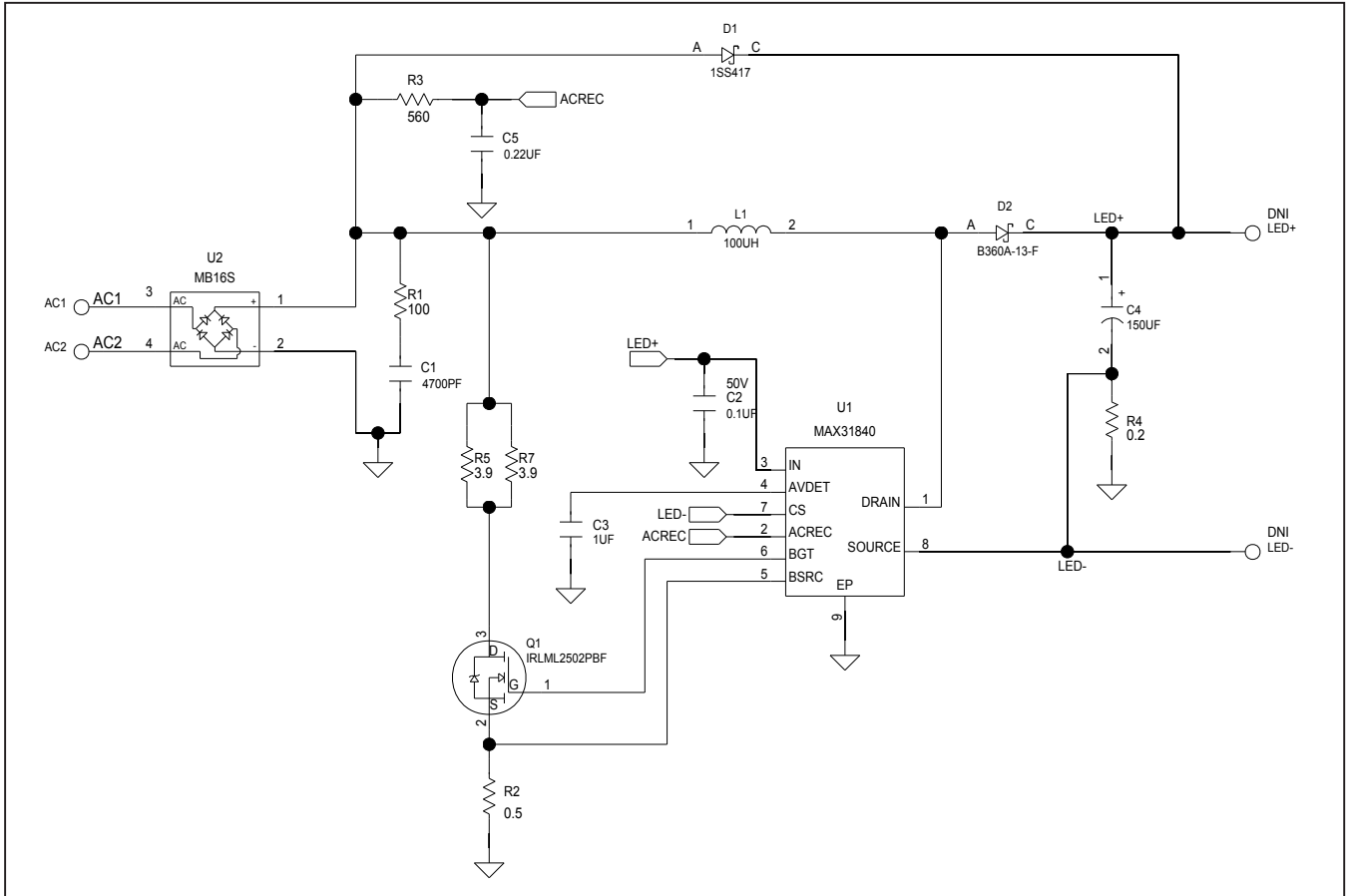

MAX31840 EV Kit PCB Layout Diagrams

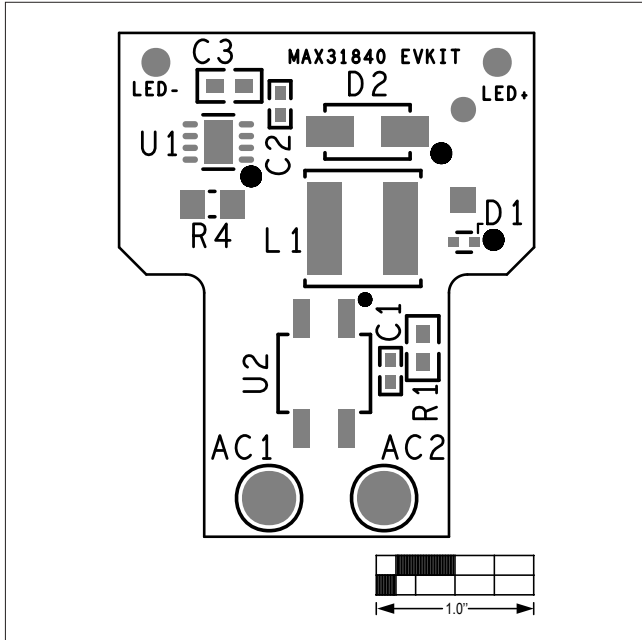

MAX31840 PCB Layout—Top Silkscreen

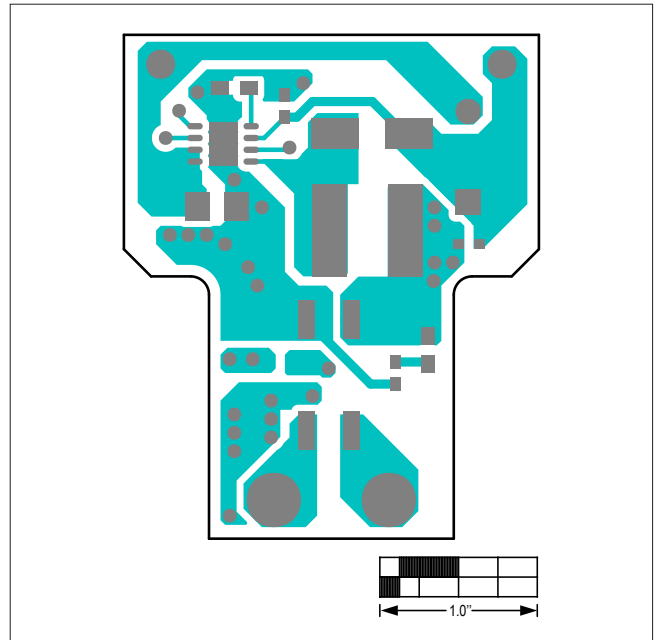

MAX31840 PCB Layout—Top

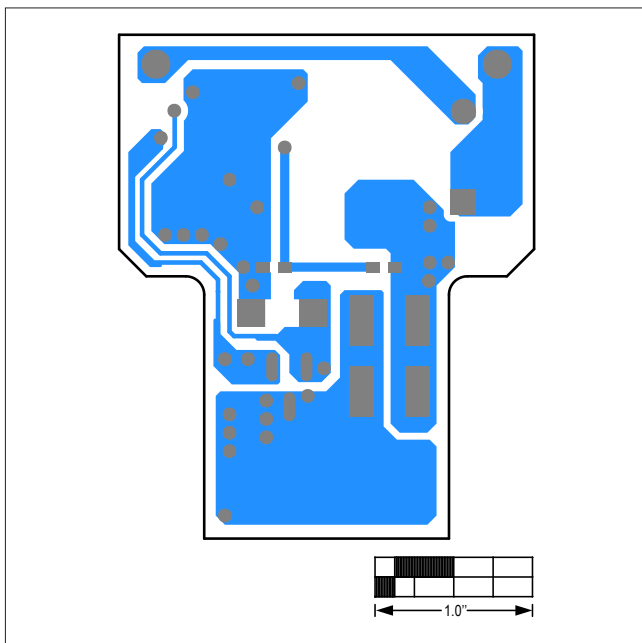

MAX31840 PCB Layout—Bottom

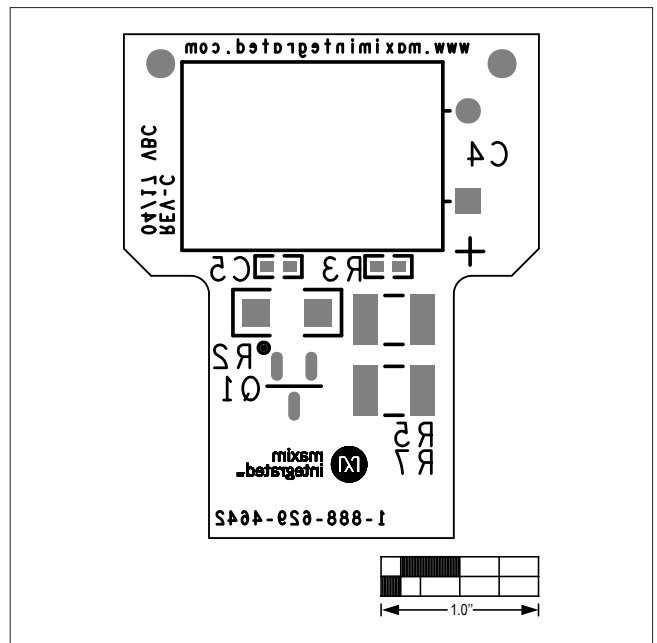

MAX31840 PCB Layout—Bottom Silkscreen

Revision History

REVISION NUMBER	REVISION DATE	DESCRIPTION	PAGES CHANGED
0	8/17	Initial release	—

For pricing, delivery, and ordering information, please contact Maxim Direct at 1-888-629-4642, or visit Maxim Integrated's website at www.maximintegrated.com.

Maxim Integrated cannot assume responsibility for use of any circuitry other than circuitry entirely embodied in a Maxim Integrated product. No circuit patent licenses are implied. Maxim Integrated reserves the right to change the circuitry and specifications without notice at any time.

X-ON Electronics

Largest Supplier of Electrical and Electronic Components

Click to view similar products for [LED Lighting Development Tools](#) category:

Click to view products by [Maxim](#) manufacturer:

Other Similar products are found below :

[MIC2870YFT EV](#) [TDGL014](#) [ISL97682IRTZEVALZ](#) [EA6358NH](#) [TPS92315EVM-516](#) [STEVAL-LLL006V1](#) [IS31LT3948-GRLS4-EB](#)
[PIM526](#) [PIM527](#) [MAX6946EVKIT+](#) [MAX20070EVKIT#](#) [MAX20090BEVKIT#](#) [PIM498](#) [AP8800EV1](#) [ZXLD1370/1EV4](#) [TLC59116EVM-](#)
[390](#) [1216.1013](#) [TPS61176EVM-566](#) [TPS92001EVM-628](#) [1270](#) [1271.2004](#) [1272.1030](#) [1273.1010](#) [1278.1010](#) [1279.1002](#) [1279.1001](#)
[1282.1000](#) [1293.1900](#) [1293.1800](#) [1293.1700](#) [1293.1500](#) [1293.1100](#) [1282.1400](#) [1282.1100](#) [1293.1200](#) [1282.1200](#) [1293.1000](#) [1282.6000](#)
[1296.2012](#) [MIKROE-2520](#) [1721](#) [1762](#) [PIR-GEVB](#) [TPS61161EVM-243](#) [TLC6C5712EVM](#) [TLC59116FEVM-571](#) [STEVAL-ILL056V1](#)
[ADM00767](#) [STEVAL-ILL080V1](#) [DC1224A](#)