

General Description

The MAX31865PMB1 peripheral module (Pmod™) provides the necessary hardware to interface the MAX31865 RTD-to-digital converter to any system that utilizes Pmod-compatible expansion ports configurable for SPI communication. The IC is an easy-to-use resistance-to-digital converter optimized for platinum resistance temperature detectors (RTDs). This module is set up to operate with a PT100 platinum RTD.

For full range accuracies, other RTD types, and detailed information regarding operation of the IC, refer to the MAX31865 IC data sheet.

Features and Benefits

- Simple Conversion of Platinum RTD Resistance to Digital Value
- Handles 100Ω to 1kΩ (at 0°C) Platinum RTDs (PT100 to PT1000)
- Compatible with 2-, 3-, and 4-Wire Sensor Connections
- 6-Pin Pmod-Compatible Connector (SPI)
- RoHS Compliant
- Proven PCB Layout
- Fully Assembled and Tested

Ordering Information appears at end of data sheet.

Peripheral Module Board Photo

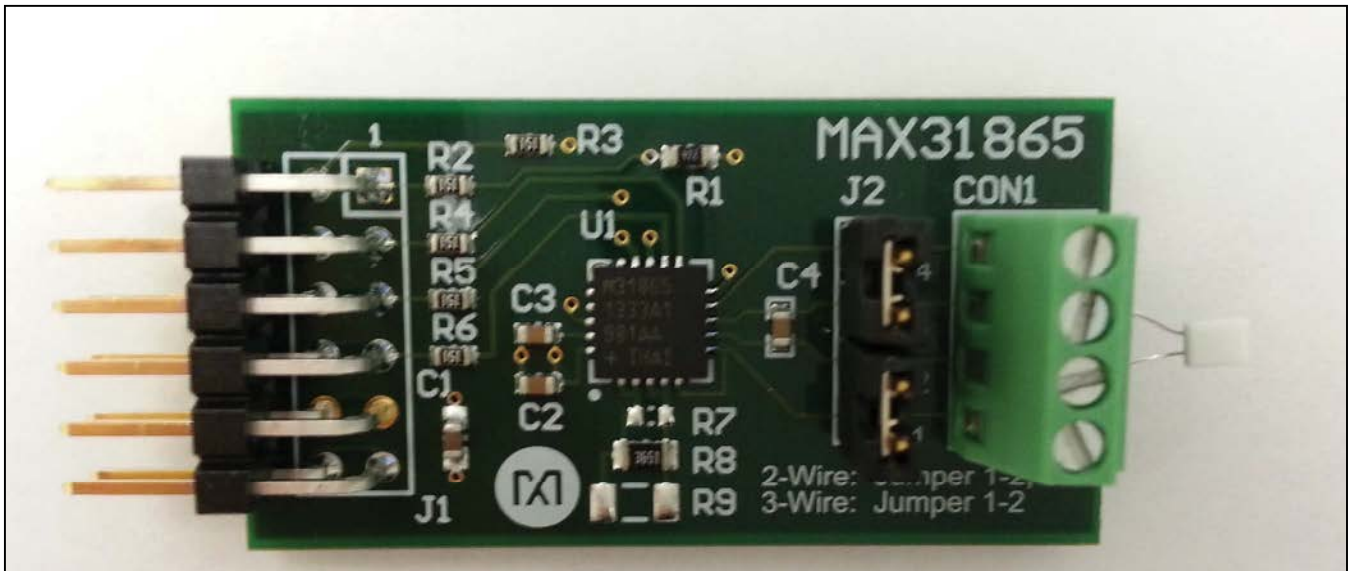

Pmod is a trademark of Digilent Inc.

Detailed Description

SPI Interface

The MAX31865PMB1 Pmod can plug directly into a Pmod-compatible port (configured for SPI) through connector J1. For information on the SPI protocol, refer to the MAX31865 IC data sheet.

J1 provides connection of the module to the Pmod host. The pin functions and pin assignments adhere to the Pmod standard recommended by Digilent. See [Table 1](#) for detailed descriptions.

CON1

Connector CON1 provides connection to the IC pins, as follows:

- Connector CON1 pin 1 connects to FORCE+ and FORCE2 (pins 5 and 6) of the IC.
- Connector CON1 pin 2 connects to RTDIN+ (pin 7) of the IC.
- Connector CON1 pin 3 connects to RTDIN- (pin 8) of the IC.
- Connector CON1 pin 4 connects to FORCE- (pin 9) of the IC.

J2

Two jumpers at J2 are provided to select either 2-wire or 3-wire RTD configuration. For 2-wire RTD, install both jumpers, from 1-2 and 3-4. For 3-wire RTD, install jumper from 3-4 only.

Power Supplies

The Pmod is powered directly by the +3.3V power supply from the MAXUSB2PMB Munich board, pins 6 and 12 of connector J1.

Software Graphical User Interface (GUI)

The Munich GUI is provided to facilitate the evaluation of the Pmod.

Visit www.maximintegrated.com/evkitsoftware to download the latest version of the Munich GUI software, PMOD_SPI.ZIP. Refer to the MAX31865PMB1 peripheral module and Munich (USB2PMB1) adapter board *Quick Start Guide* for step-by-step evaluation using the Munich GUI.

Table 1. Connector J1 (SPI Communication)

PIN	SIGNAL	DESCRIPTION
1	SS	Chip Select. Assert low to enable the SPI interface.
2	MOSI	MAX31865 Serial-Data Input
3	MISO	MAX31865 Serial-Data Output
4	SCLK	MAX31865 Serial-Clock Input
5, 11	GND	Ground
6, 12	V _{CC}	+3.3V Power Supplies
7	DRDY	Active-Low Push-Pull Data-Ready Output. $\overline{\text{DRDY}}$ goes low when a new conversion result is available in the data register. When a read-operation of an RTD resistance data register occurs, DRDY returns high.
8–10	—	No Connection

Component List

DESIGNATION	QTY	DESCRIPTION
C1	1	1 μ F \pm 10%, 25V X7R ceramic capacitor (0603) TDK C1608X7R1E105K080AB
C2–C4	3	0.1 μ F \pm 10%, 25V XR7 ceramic capacitors (0603) TDK C1608X7R1E104K080AA
CON1	1	4-position screw terminal, 2.54mm pitch Phoenix Contact 1725672
J1	1	12-pin connector header, .100 R/A 15AU FC1 68021-212HLF
J2	1	4-pin header Molex 0757570441

DESIGNATION	QTY	DESCRIPTION
R1	1	4.7k Ω \pm 5% resistor (0603)
R2–R6	5	150 Ω \pm 5% resistors (0603)
R7	1	400 Ω \pm 0.1% resistor (0603)
R8	0	Not installed, 400 Ω \pm 0.1% resistor (0805)
R9	0	Not installed, 400 Ω \pm 0.1% resistor (1206)
U1	1	RTD-to-digital converter (20 TQFN-EP*) Maxim MAX31865ATP+
—	1	100 Ω platinum-chip temperature sensor, leaded Reichelt Elektronik PCA1.1505 1 or equivalent

*EP = Exposed pad.

Component Suppliers

SUPPLIER	PHONE	WEBSITE
Molex	800-786-6539	www.molex.com
Phoenix Contact	717-944-1300	www.phoenixcontact.com
Reichelt Elektronik	49 (0) 4422-955-333	www.reichelt.com
TDK Corp.	847-803-6100	www.component.tdk.com

Note: Indicate that you are using the MAX31865PMB1 when contacting these component suppliers.

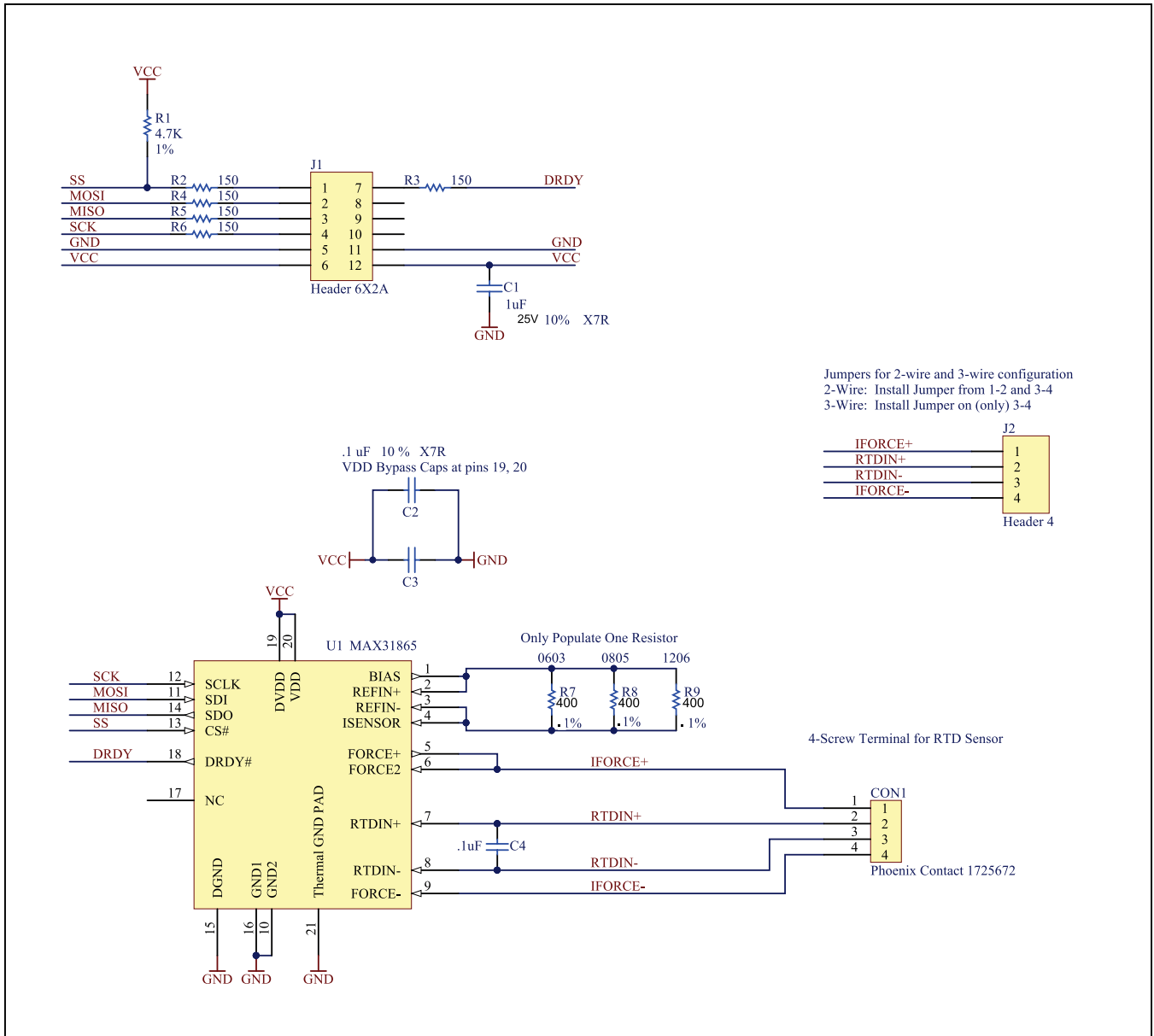

Figure 1. MAX31865PMB1 Peripheral Module Schematic

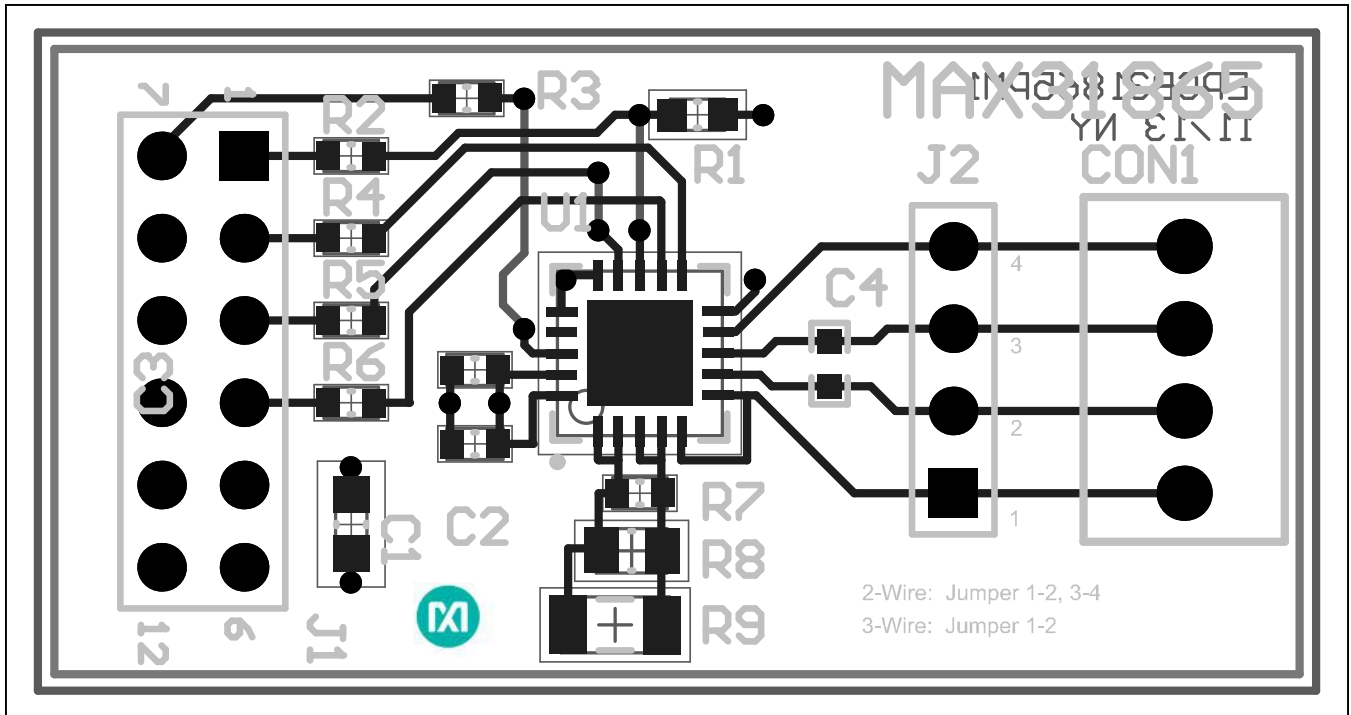

Figure 2. MAX31865PMB1 Peripheral Module Component Placement Guide—Top

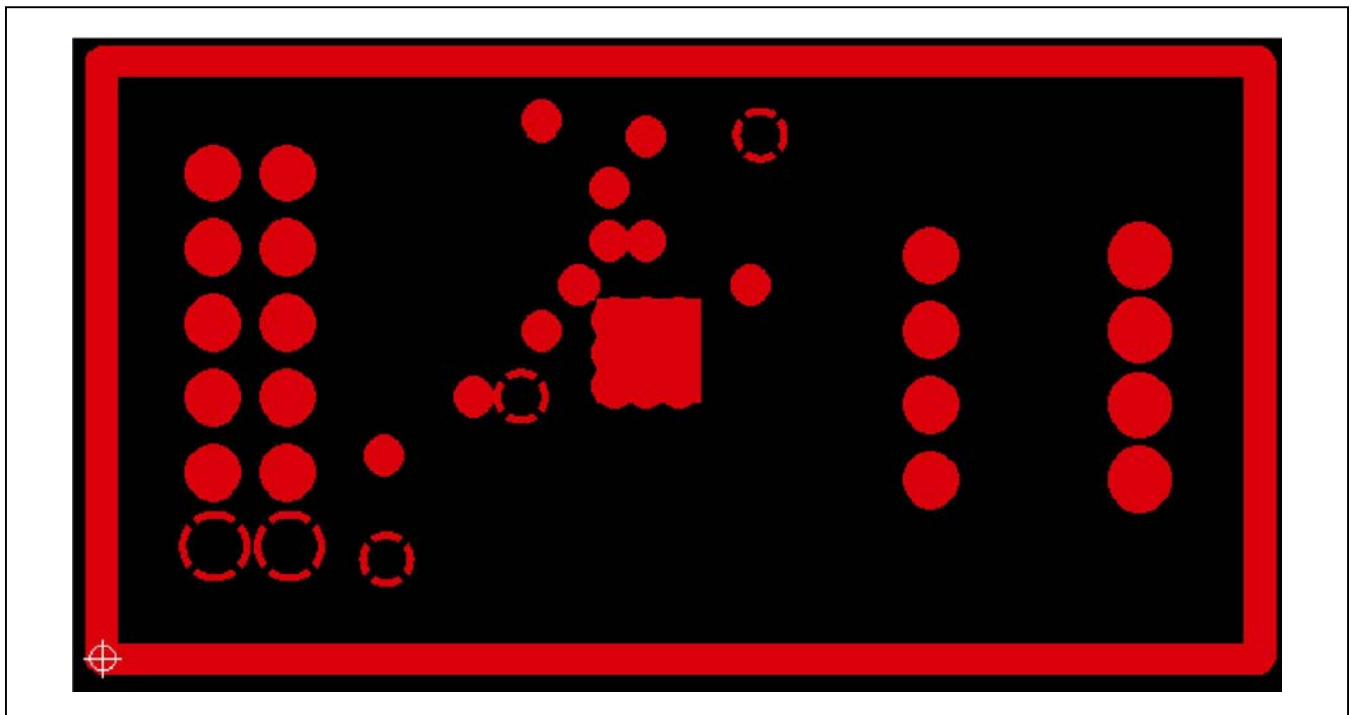

Figure 3. MAX31865PMB1 Peripheral Module Component Placement Guide—Bottom

Ordering Information

PART	TYPE
MAX31865PMB1#	Peripheral Module

#Denotes RoHS compliant.

Revision History

REVISION NUMBER	REVISION DATE	DESCRIPTION	PAGES CHANGED
0	1/14	Initial release	—

For pricing, delivery, and ordering information, please contact Maxim Direct at 1-888-629-4642, or visit Maxim Integrated's website at www.maximintegrated.com.

Maxim Integrated cannot assume responsibility for use of any circuitry other than circuitry entirely embodied in a Maxim Integrated product. No circuit patent licenses are implied. Maxim Integrated reserves the right to change the circuitry and specifications without notice at any time.

X-ON Electronics

Largest Supplier of Electrical and Electronic Components

Click to view similar products for [Data Conversion IC Development Tools](#) category:

Click to view products by [Maxim](#) manufacturer:

Other Similar products are found below :

[EVAL-AD7265EDZ](#) [EVAL-AD7719EBZ](#) [EVAL-AD7767-1EDZ](#) [EVAL-AD7995EBZ](#) [AD9211-200EBZ](#) [AD9251-20EBZ](#) [AD9251-65EBZ](#)
[AD9613-170EBZ](#) [AD9629-20EBZ](#) [AD9716-DPG2-EBZ](#) [AD9737A-EBZ](#) [AD9993-EBZ](#) [DAC8555EVM](#) [EVAL-AD5061EBZ](#) [EVAL-](#)
[AD5062EBZ](#) [EVAL-AD5443-DBRDZ](#) [EVAL-AD5570SDZ](#) [EVAL-AD7992EBZ](#) [EVAL-AD7994EBZ](#) [AD9119-MIX-EBZ](#) [AD9233-125EBZ](#)
[AD9629-80EBZ](#) [AD9650-80EBZ](#) [AD9767-EBZ](#) [DAC8531EVM](#) [LM96080EB/NOPB](#) [EVAL-AD5445SDZ](#) [EVAL-AD5660EBZ](#) [EVAL-](#)
[AD7685SDZ](#) [EVAL-AD7687SDZ](#) [MAX5318PMB#](#) [MAX1246EVL11-QSOP](#) [MAX117EVKIT-DIP](#) [DC2365A-C](#) [DC2795A-B](#) [DC2795A-A](#)
[DAC088S085EB/NOPB](#) [SIM8909-EVB-KIT](#) [82635ASRCDVKHV 961443](#) [DC1466B-B](#) [EVAL-AD5413SDZ](#) [ADC12D1600RB/NOPB](#) [1083](#)
[RFPDK FOR CMT2X5X](#) [TS7003DB](#) [TSC2014EVM-PDK](#) [MOD-USB3G](#) [KDC5514EVALZ](#) [650201392G](#) [ISL28005FH-100EVAL1Z](#)