

General Description

The MAX31914/MAX31915 evaluation kits (EV kits) provide the hardware necessary to evaluate the MAX31914 and MAX31915 industrial octal digital input translators. There is no software required for this EV kit.

EV Kit Contents

- Assembled circuit board including MAX31915

Features

- Easy Evaluation of the MAX31914 and MAX31915
- RoHS Compliant
- Proven PCB Layout
- Fully Assembled and Tested

[Ordering Information](#) appears at end of data sheet.

MAX31915 EV Kit Photo

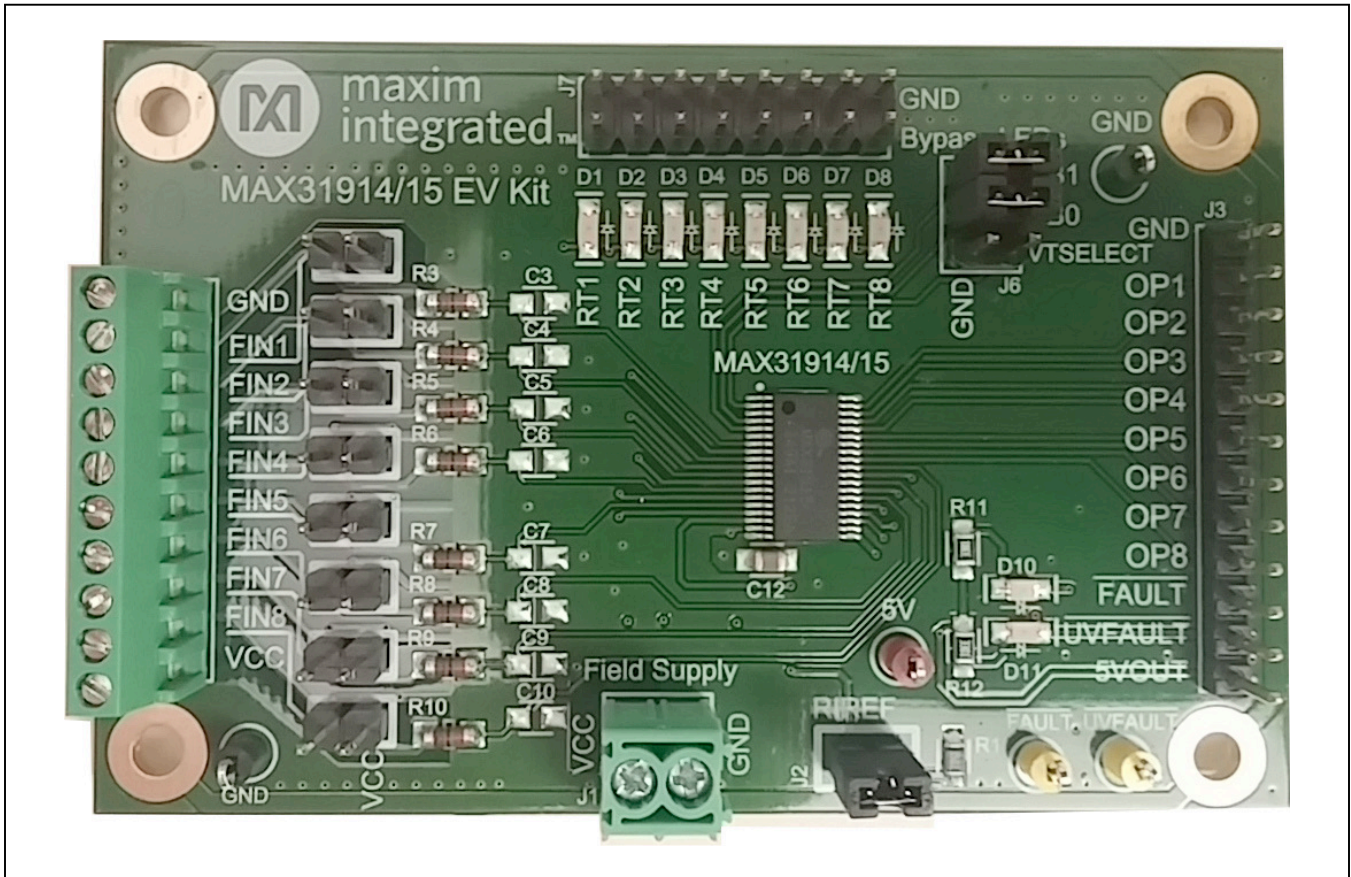

Quick Start

Required Equipment

- MAX31914 and MAX31915 EV kits
- EV kit hardware (included)
- Screwdriver
- Wire
- 24V power supply

Procedure

The EV kit is fully assembled and tested. Follow the steps below to verify board operation:

- 1) Install a jumper on RIREF (J2).
- 2) Set the EV kit hardware on a nonconductive surface to ensure that nothing on the PCB gets shorted to the workspace.
- 3) Use the wires to connect J1 (VCC and GND) to a 24V power supply and tighten the screws on the wire.
- 4) Connect field inputs to J5 or install jumpers on FIN1–FIN8 to get the CMOS translation on J3 pins OP1–OP8.

Detailed Description of Hardware

Connect Field Inputs

To connect field inputs to the PCB, remove all pullup jumpers (FIN1–FIN8). Connect the field inputs to screw terminal J5 or to the left pin of jumpers FIN1–FIN8.

Adjust Current Limit

To adjust the current limit, remove the jumper on J2 and connect an external resistor to the RIREF pin on J2. Connect the other end of the resistor to GND. Another option is to keep the jumper on J2 populated and change the value of R1.

CMOS Logic Compatible Levels

To set the input trip points to CMOS logic compatible levels, populate the VTSELECT jumper on J6. When in this mode, the RTX pins must be grounded by populating the jumpers on J7 to bypass the LEDs. The reference resistor (R1) must also be changed to 100kΩ to adjust the current limit.

Table 1. Description of Jumpers

JUMPER	DESCRIPTION
J2	RIREF: Connects R1 to the RIREF pin.
J6*	DB0: Pulls DB0 down to GND. Used to select digital glitch filter.
	DB1: Pulls DB1 down to GND. Used to select digital glitch filter.
	VTSELECT: Pulls VTSELECT down to GND to set the field input trip points to CMOS-compatible logic. See the CMOS Logic-Compatible Levels section for more details.
J7	Bypass LEDs: Connects return path RTX to GND to bypass the LED.
FIN1–FIN8	Field Inputs Pullup: Connects field input FINX to VIN.

*These inputs have internal pullups.

Table 2. Description of LEDs (D1–D11)

LED	COLOR	DESCRIPTION
D1–D8	Red	Field Inputs: Field input is logic-high.
D10	Red	$\overline{\text{FAULT}}$: The device has detected a fault. Either the field-supply voltage is too low, the IC temperature is too high, or both.
D11	Red	$\overline{\text{UVFAULT}}$: The device has an undervoltage fault indicating the field supply voltage is too low.

Component Suppliers

SUPPLIER	WEBSITE
Bourns	www.bourns.com
ON Semiconductor	www.onsemi.com
Phoenix Contact	www.phoenixcontact.com
TE Connectivity	www.te.com
TDK Corp.	www.tdk.com
Vishay	www.vishay.com

Note: Indicate that you are using the MAX31915 when contacting these component suppliers..

Component List, PCB Files and Schematics

See the following links for component information, PCB files, and schematics:

- [MAX31914/MAX31915 EV BOM](#)
- [MAX31914/MAX31915 EV PCB Files](#)
- [MAX31914/MAX31915 EV Schematics](#)

Ordering Information

PART	TYPE
MAX31914EVKIT#	EV Kit
MAX31915EVKIT#	EV Kit

#Denotes RoHS compliant.

Revision History

REVISION NUMBER	REVISION DATE	DESCRIPTION	PAGES CHANGED
0	8/13	Initial release	—
1	5/15	Added MAX31914 information to EV kit data sheet	1-7

For pricing, delivery, and ordering information, please contact Maxim Direct at 1-888-629-4642, or visit Maxim Integrated's website at www.maximintegrated.com.

Maxim Integrated cannot assume responsibility for use of any circuitry other than circuitry entirely embodied in a Maxim Integrated product. No circuit patent licenses are implied. Maxim Integrated reserves the right to change the circuitry and specifications without notice at any time.

MAXIM

MAXIM_Logo

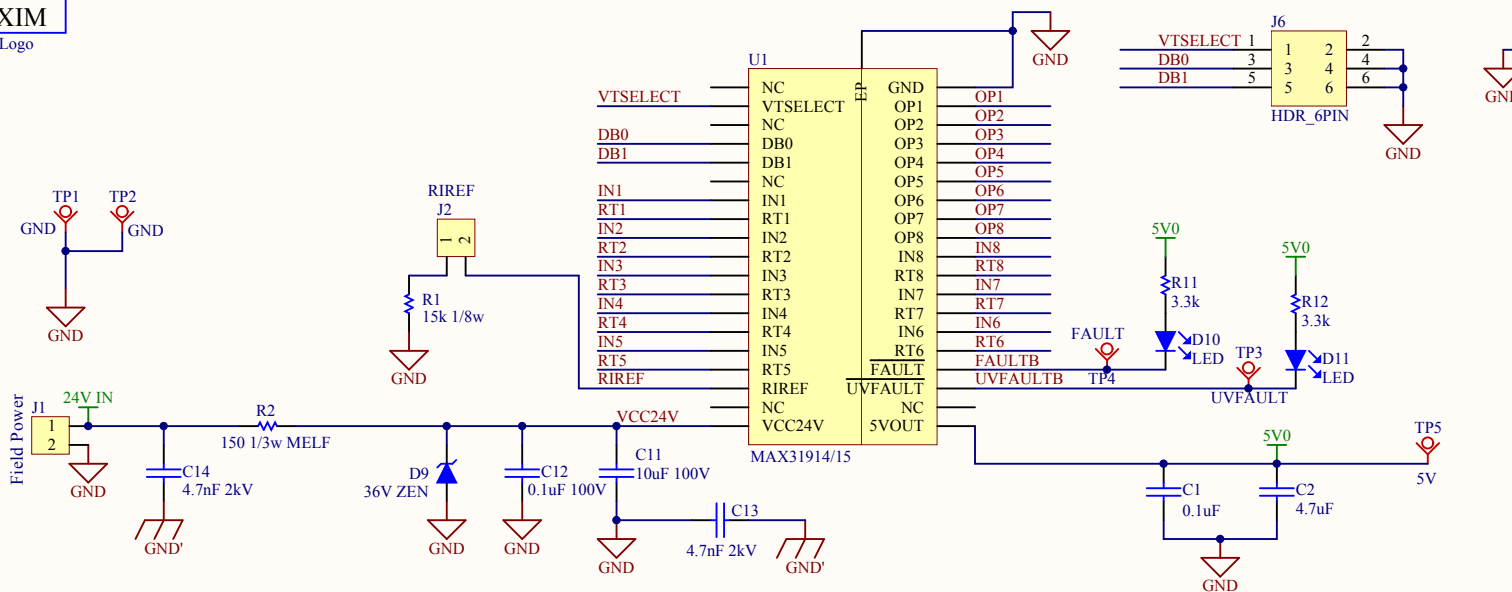

Input Filter Bank

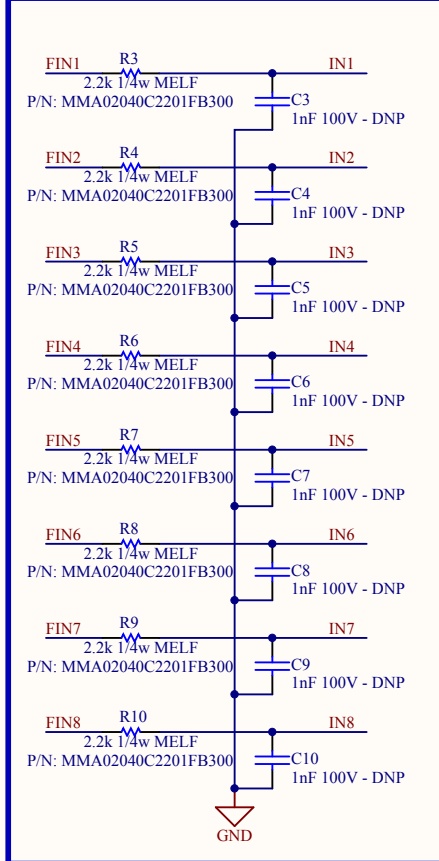

Input Indicator Bank

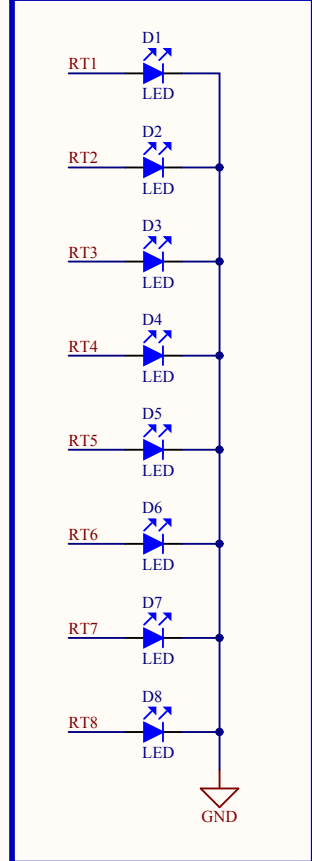

LED Bypass

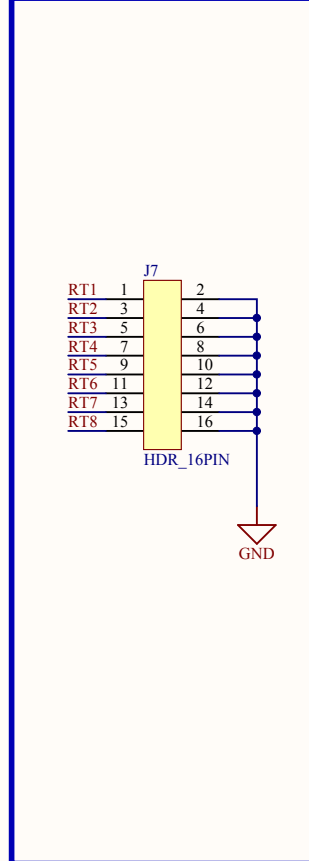

Field Input Pull ups

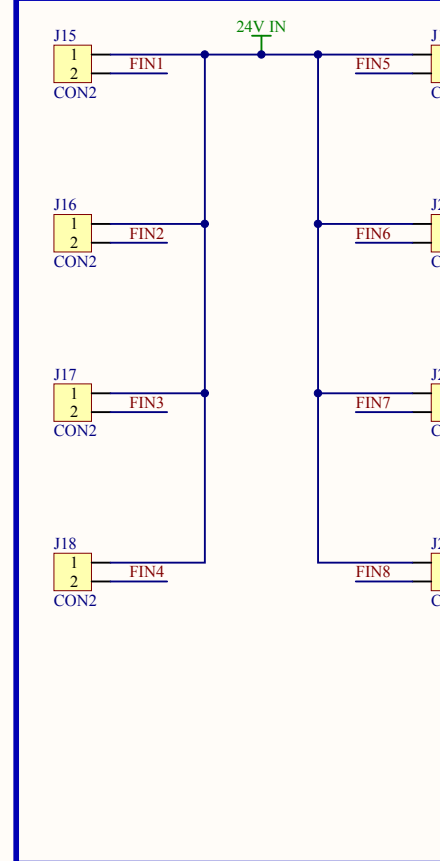

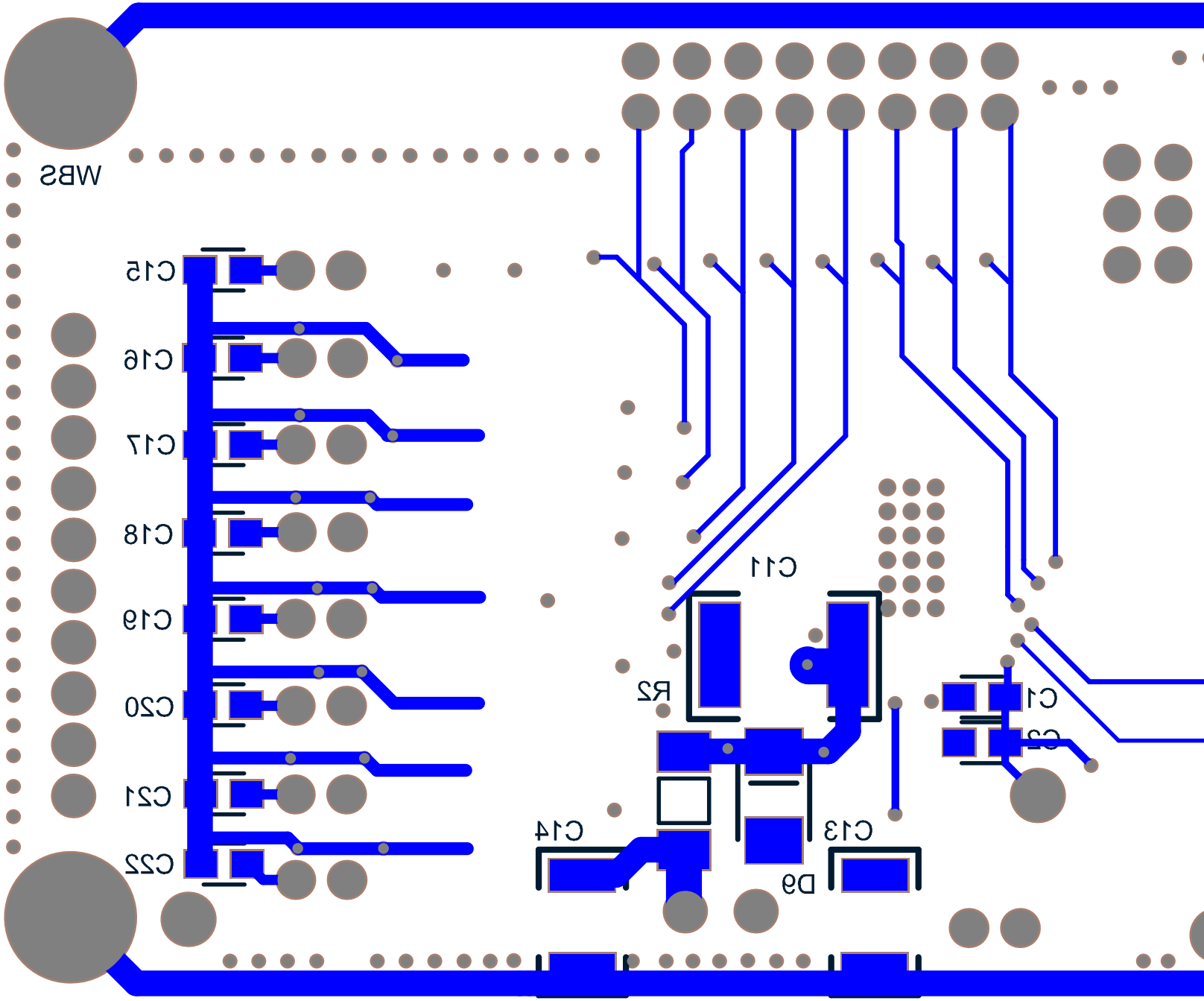



maxim
integrated™

MAX31914/15 EV Kit

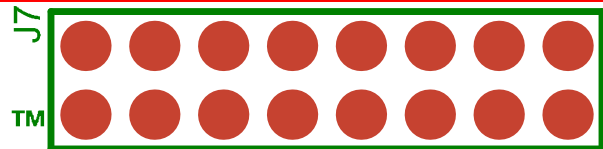

GND
Bypass LE

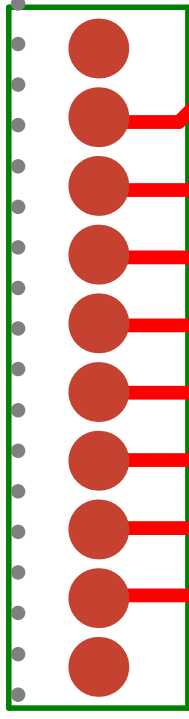
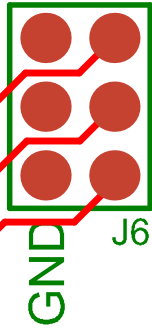
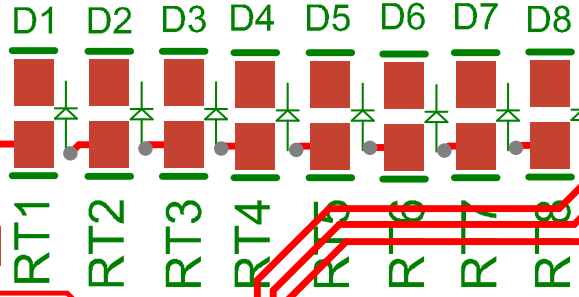

GND
FIN1
FIN2
FIN3
FIN4
FIN5
FIN6
FIN7
FIN8
VCC

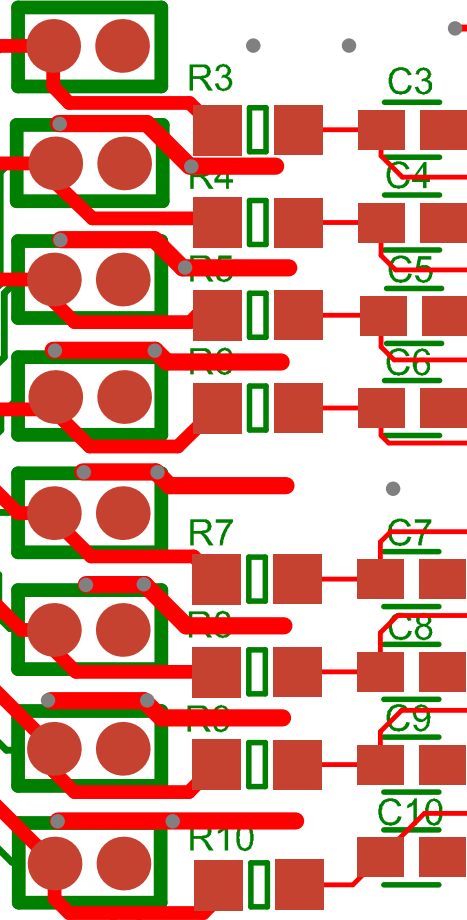

MAX31914/15

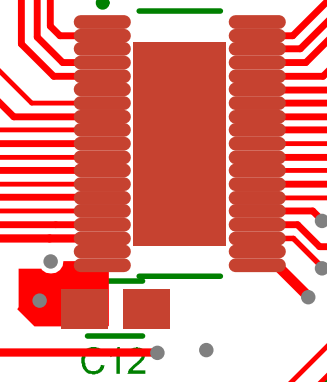

Field Supply

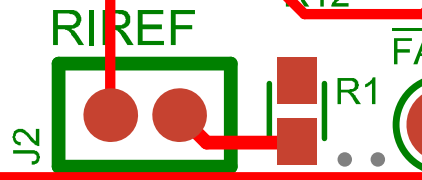
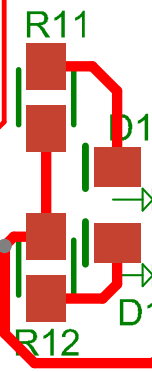

GND
VCC

VCC

GND

R1 REF

FA



maxim
integrated

MAX31914/15 EV Kit

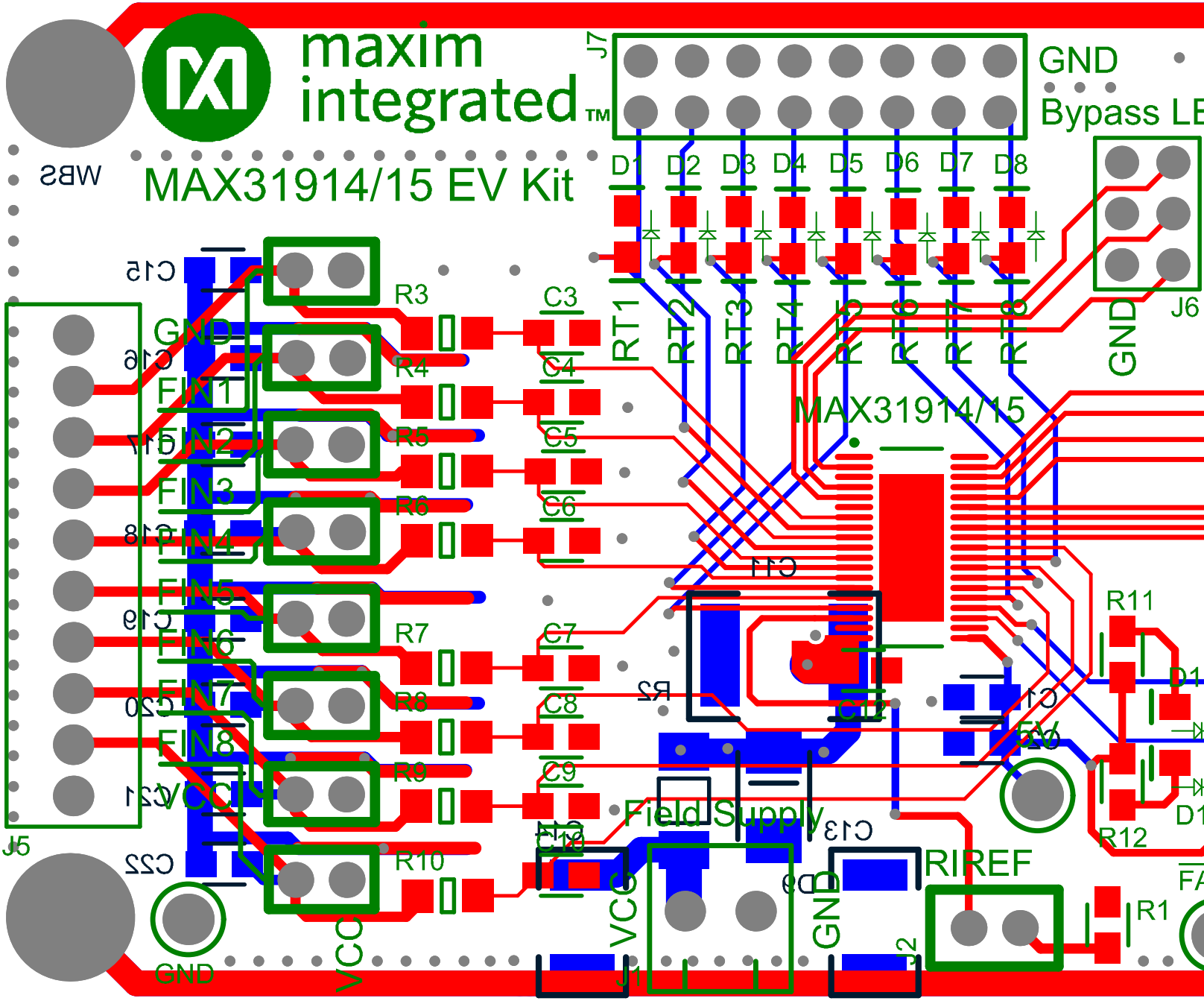

WB2

J5
GND
FIN1
FIN2
FIN3
FIN4
FIN5
FIN6
FIN7
FIN8
VCC

J7
GND
Bypass LE
D1 D2 D3 D4 D5 D6 D7 D8
RT1 RT2 RT3 RT4 RT5 RT6 RT7 RT8
GND
J6

MAX31914/15
Field Supply
R11
R12
D1
D2
D3
D4
D5
D6
D7
D8
R1
R2
R3
R4
R5
R6
R7
R8
R9
R10
C1
C2
C3
C4
C5
C6
C7
C8
C9
GND
VCC
GND
R1REF
FA

BILLS OF MATERIALS (BOM) 5/15 Revision

Comment	Designator	Quan	PN#	MFG
0.1uF	C1, C12	2	CGA4J2X7R2A104K	TDK
4.7uF	C2	1	CGA4J3X5R1H475K	TDK
10uF 60V	C11	1	C5750X7S2A106M	TDK
36V ZEN	D9	1	1SMB36AT3G	ON Semi
LED	D1, D2, D3, D4, D5, D6, D7, D8, D10, D11	10	HSMS-C170	Avago Technologies
Phoenix Contact 1984617	J1	1	1984617	Phoenix Contact
CON10	J5	1	1-282834-0	TE Connectivity
RIREF, FIN1, FIN2, FIN3, FIN4, FIN5, FIN6, FIN7 FIN8, VCC, RIREF	J2, J15, J16, J17, J18, J19, J20, J21, J22	9	961102-6404-AR	3M
15k 1/8w	R1	1	CRCW080515K0FKEA	Vishay/Dale
150 1/3w MELF	R2	1	MMB02070C1500FB20 0	Vishay
2.2k 1/4w MELF	R3, R4, R5, R6, R7, R8, R9, R10	8	MMA02040C2201FB30 0	Vishay
3.3k	R11, R12	2	CRCW0805560RFKEA	Vishay/Dale
GND	TP1, TP2	2	5001	Keystone (02- TPMINI5001-00)
5V	TP5	1	5000	Keystone (02- TPMINI5000-00)
4700pF - 2kV Caps	C13, C14	2	1812GC472KAT1A	AVX
1nF- 1kV	C15, C16, C17, C18, C19, C20, C21, C22	8	C0805C102KDRACTU	Kemet
Jumpers		9	969102-0000-DA	3M
CON	J3	1	M20-9991245	Harwin
HDR_6PIN	J6	1	961206-6404-AR	3M
HDR_16PIN	J7	1	961216-6404-AR	3M

UVFAULT, FAULT	TP3, TP4	2	5004	Keystone (02- TPMINI5004-00)
MAX31914/1 5	U1	1		

X-ON Electronics

Largest Supplier of Electrical and Electronic Components

Click to view similar products for [Interface Development Tools](#) category:

Click to view products by [Maxim](#) manufacturer:

Other Similar products are found below :

[ADP5585CP-EVALZ](#) [CHA2066-99F](#) [AS8650-DB](#) [MLX80104 TESTINTERFACE](#) [416100120-3](#) [XR18910ILEVB](#) [XR21B1421IL28-0A-EVB](#) [TW-DONGLE-USB](#) [EVAL-ADM2491EEBZ](#) [MAXREFDES23DB#](#) [MAX13235EEVKIT](#) [DFR0257](#) [XR22404CG28EVB](#) [ZLR964122L](#) [ZLR88822L](#) [EVK-U23-01S](#) [EVK-W262U-00](#) [DC327A](#) [PIM511](#) [PIM536](#) [PIM517](#) [DEV-17512](#) [STR-FUSB3307MPX-PPS-GEVK](#) [MAXREFDES177#](#) [EVAL-ADM2567EEBZ](#) [ZSSC3240KIT](#) [MAX9121EVKIT](#) [PIM532](#) [ZSC31010KITV2P1](#) [UMFT4233HPEV](#) [LVDS-18B-EVK](#) [XR20M1170G16-0B-EB](#) [XR20M1170G24-0B-EB](#) [XR20M1172G28-0A-EB](#) [XR20M1172G28-0B-EB](#) [SI871XSOIC8-KIT](#) [1764](#) [1833](#) [1862](#) [EVB-USB82514](#) [ATA6628-EK](#) [ATA6631-EK](#) [EVAL-CN0313-SDPZ](#) [2264](#) [MCP23X17EV](#) [PS081-EVA-HR MODULE](#) [237](#) [SMA2RJ45EVK/NOPB](#) [FR12-0002](#) [MAFR-000455-001](#)