



Precision, Dual-Supply, SPST Analog Switches

MAX320/MAX321/MAX322

General Description

The MAX320/MAX321/MAX322 are precision, dual, SPST analog switches designed to operate from $\pm 3V$ to $\pm 8V$ dual supplies. The MAX320 has two normally open (NO) switches and the MAX321 has two normally closed (NC) switches. The MAX322 has one NO and one NC switch. Low power consumption (1.25mW) makes these parts ideal for battery-powered equipment. They offer low leakage currents (100pA max) and fast switching speeds ($t_{ON} = 150ns$ max, $t_{OFF} = 100ns$ max).

The MAX320 series, powered from $\pm 5V$ supplies, offers 35 Ω max on-resistance (R_{ON}), 2 Ω max matching between channels, and 4 Ω max R_{ON} flatness.

These switches also offer 5pC max charge injection and a minimum of 2000V ESD protection per Method 3015.7.

For equivalent devices specified for single-supply operation, see the MAX323/MAX324/MAX325 data sheet. For quad versions of these switches, see the MAX391/MAX392/MAX393 data sheet.

Applications

- | | |
|---------------------------|------------------------------|
| Battery-Operated Systems | Sample-and-Hold Circuits |
| Heads-Up Displays | Guidance and Control Systems |
| Audio and Video Switching | Military Radios |
| Test Equipment | Communications Systems |
| $\pm 5V$ DACs and ADCs | PBX, PABX |

Features

- ◆ Low On-Resistance, 35 Ω max (16 Ω typical)
- ◆ R_{ON} Matching Between Channels <2 Ω
- ◆ R_{ON} Flatness <4 Ω
- ◆ Guaranteed Charge Injection <5pC
- ◆ Bipolar Supply Operation ($\pm 3V$ to $\pm 8V$)
- ◆ Low Power Consumption, <1.25mW
- ◆ Low Leakage Current Over Temperature, <2.5nA at +85 $^{\circ}C$
- ◆ Fast Switching, $t_{ON} < 150ns$, $t_{OFF} < 100ns$
- ◆ Guaranteed Break-Before-Make (MAX322 only)

Ordering Information

PART	TEMP. RANGE	PIN-PACKAGE
MAX320CPA	0 $^{\circ}C$ to +70 $^{\circ}C$	8 Plastic DIP
MAX320CSA	0 $^{\circ}C$ to +70 $^{\circ}C$	8 SO
MAX320CUA	0 $^{\circ}C$ to +70 $^{\circ}C$	8 μ MAX
MAX320C/D	0 $^{\circ}C$ to +70 $^{\circ}C$	Dice*
MAX320EPA	-40 $^{\circ}C$ to +85 $^{\circ}C$	8 Plastic DIP
MAX320ESA	-40 $^{\circ}C$ to +85 $^{\circ}C$	8 SO
MAX320EJA	-40 $^{\circ}C$ to +85 $^{\circ}C$	8 CERDIP**
MAX320MJA	-55 $^{\circ}C$ to +125 $^{\circ}C$	8 CERDIP**

Ordering Information continued at end of data sheet.

* Contact factory for dice specifications.

** Contact factory for availability.

Pin Configurations/Functional Diagrams/Truth Tables

TOP VIEW

MAX320
DIP/SO/ μ MAX

MAX320	
LOGIC	SWITCH
0	OFF
1	ON

MAX321
DIP/SO/ μ MAX

MAX321	
LOGIC	SWITCH
0	ON
1	OFF

MAX322
DIP/SO/ μ MAX

MAX322		
LOGIC	SWITCH 1	SWITCH 2
0	OFF	ON
1	ON	OFF

SWITCHES SHOWN FOR LOGIC "0" INPUT



Precision, Dual-Supply, SPST Analog Switches

ABSOLUTE MAXIMUM RATINGS

Voltage Referenced to V-	μ MAX (derate 4.10mW/°C above +70°C)330mW
V+(V- - 0.3V) to +17V	CERDIP (derate 8.00mW/°C above +70°C)640mW
IN ₋ , COM ₋ , NC ₋ , NO ₋ (Note 1)(V- - 0.3V) to (V+ + 0.3V)	Operating Temperature Ranges
Continuous Current (any terminal)30mA	MAX32_C_ _0°C to +70°C
Peak Current, COM ₋ , NO ₋ , NC ₋	MAX32_E_ _-40°C to +85°C
(pulsed at 1ms, 10% duty cycle max)100mA	MAX32_MJA-55°C to +125°C
ESD per Method 3015.7>2000V	Storage Temperature Range-65°C to +150°C
Continuous Power Dissipation	Lead Temperature (soldering, 10sec)+300°C
Plastic DIP (derate 9.09mW/°C above +70°C)727mW	
Narrow SO (derate 5.88mW/°C above +70°C)471mW	

Note 1: Signals on NC₋, NO₋, COM₋, or IN₋ exceeding V+ or V- are clamped by internal diodes. Limit forward diode current to maximum current rating.

Stresses beyond those listed under "Absolute Maximum Ratings" may cause permanent damage to the device. These are stress ratings only, and functional operation of the device at these or any other conditions beyond those indicated in the operational sections of the specifications is not implied. Exposure to absolute maximum rating conditions for extended periods may affect device reliability.

ELECTRICAL CHARACTERISTICS

(V+ = +5V ±10%, V- = -5V ±10%, V_{INH} = 3.5V, V_{INL} = 2.5V, T_A = T_{MIN} to T_{MAX}, unless otherwise noted.)

PARAMETER	SYMBOL	CONDITIONS	MIN	TYP (Note 2)	MAX	UNITS		
ANALOG SWITCH								
Analog Signal Range	V _{COM} , V _{NO} , V _{NC}	(Note 3)	V-		V+	V		
On-Resistance	R _{ON}	V+ = 4.5V, V- = -4.5V, I _{COM} = 1.0mA, V _{NO} or V _{NC} = ±3.5V	T _A = +25°C	C, E	16	35	Ω	
				M	16	30		
			T _A = T _{MIN} to T _{MAX}			45		
On-Resistance Match Between Channels (Note 4)	ΔR _{ON}	V+ = 5V, V- = -5V, I _{COM} = 1.0mA, V _{NO} or V _{NC} = ±3V	T _A = +25°C		0.3	2	Ω	
			T _A = T _{MIN} to T _{MAX}			4		
On-Resistance Flatness (Note 5)	R _{FLAT(ON)}	V+ = 5V, V- = -5V, I _{COM} = 1.0mA, V _{NO} or V _{NC} = ±3V	T _A = +25°C		1	4	Ω	
			T _A = T _{MIN} to T _{MAX}			6		
NO or NC Off Leakage Current (Note 6)	I _{NO(OFF)} or I _{NC(OFF)}	V+ = 5.5V, V- = -5.5V, V _{COM} = ±4.5V, V _{NO} or V _{NC} = ±4.5V	T _A = +25°C		-0.1	0.01	0.1	nA
			T _A = T _{MIN} to T _{MAX}	C, E	-5		5	
				M	-40		40	
COM Off Leakage Current (Note 6)	I _{COM(OFF)}	V+ = 5.5V, V- = -5.5V, V _{COM} = ±4.5V, V _{NO} or V _{NC} = ±4.5V	T _A = +25°C		-0.1	0.01	0.1	nA
			T _A = T _{MIN} to T _{MAX}	C, E	-5		5	
				M	-40		40	
COM On Leakage Current (Note 6)	I _{COM(ON)}	V+ = 5.5V, V- = -5.5V, V _{COM} = ±4.5V, V _{NO} or V _{NC} = ±4.5V	T _A = +25°C		-0.2	0.05	0.2	nA
			T _A = T _{MIN} to T _{MAX}	C, E	-10		10	
				M	-50		50	

Precision, Dual-Supply, SPST Analog Switches

MAX320/MAX321/MAX322

ELECTRICAL CHARACTERISTICS

(V+ = +5V ±10%, V- = -5V ±10%, VINH = 3.5V, VINL = 2.5V, TA = TMIN to TMAX, unless otherwise noted.)

PARAMETER	SYMBOL	CONDITIONS	MIN	TYP (Note 2)	MAX	UNITS	
LOGIC INPUT							
Input Current with Input Voltage High	I _{INH}		-0.5	0.005	0.5	μA	
Input Current with Input Voltage Low	I _{INL}		-0.5	0.005	0.5	μA	
Input Voltage High	V _{INH}	V+ = 5V ±10%, V- ≤ 0V	3.5			V	
		3V < V+ < 8V, V- ≤ 0V	V+ - 1.5				
Input Voltage Low	V _{INL}	V+ = 5V ±10%, V- ≤ 0V	2.5			V	
		3V < V+ < 8V, V- ≤ 0V	V+ - 2.5				
DYNAMIC							
Turn-On Time	t _{ON}	V _{COM} = ±3V, Figure 2	TA = +25°C	65	150	ns	
			TA = TMIN to TMAX	175			
Turn-Off Time	t _{OFF}	V _{COM} = ±3V, Figure 2	TA = +25°C	35	100	ns	
			TA = TMIN to TMAX	150			
Break-Before-Make Time Delay (Note 3)	t _D	MAX322 only, RL = 300Ω, CL = 35pF, Figure 3	2	5		ns	
Charge Injection (Note 3)	Q	CL = 1.0nF, VGEN = 0V, RGEN = 0Ω, Figure 4	TA = +25°C	2	5	pC	
Off Isolation (Note 7)	OIRR	RL = 50Ω, CL = 5pF, f = 1MHz, Figure 5	TA = +25°C	72		dB	
Crosstalk (Note 8)		RL = 50Ω, CL = 5pF, f = 1MHz, Figure 6	TA = +25°C	85		dB	
NC or NO Capacitance	C _(OFF)	f = 1MHz, Figure 7	TA = +25°C	9		pF	
COM Off Capacitance	C _{COM(OFF)}	f = 1MHz, Figure 7	TA = +25°C	9		pF	
COM On Capacitance	C _{COM(ON)}	f = 1MHz, Figure 8	TA = +25°C	22		pF	
SUPPLY							
Power-Supply Range			±2.7		±8	V	
Positive Supply Current	I+	V+ = 5.5V, V- = -5.5V, VIN = 0V or V+, all channels on or off	TA = +25°C	-125	80	125	μA
			TA = TMIN to TMAX	-200	200		
Negative Supply Current	I-	V+ = 5.5V, V- = -5.5V, VIN = 0V or V+, all channels on or off	TA = +25°C	-125	80	125	μA
			TA = TMIN to TMAX	-200	200		

Note 2: The algebraic convention where the most negative value is a minimum and the most positive value a maximum is used in this data sheet.

Note 3: Guaranteed by design.

Note 4: ΔRON = ΔRON max - ΔRON min.

Note 5: Flatness is defined as the difference between the maximum and minimum value of on-resistance as measured over the specified analog signal range.

Note 6: Leakage parameters are 100% tested at maximum rated hot temperature and guaranteed by correlation at +25°C.

Note 7: Off Isolation = 20 log₁₀ [V_{COM} / (V_{NC} or V_{NO})]. V_{COM} = output, V_{NC} or V_{NO} = input to off switch.

Note 8: Between any two switches.

Precision, Dual-Supply, SPST Analog Switches

Typical Operating Characteristics

($V_+ = +5V$, $V_- = -5V$, $T_A = +25^\circ C$, unless otherwise noted.)

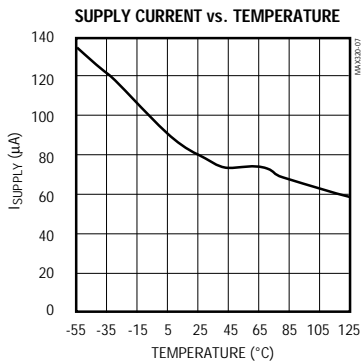
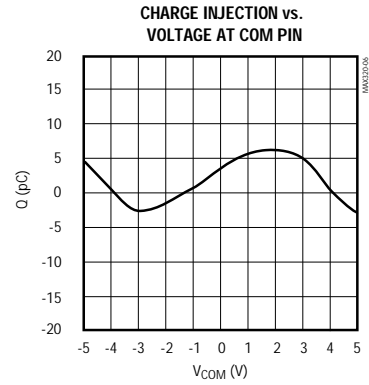
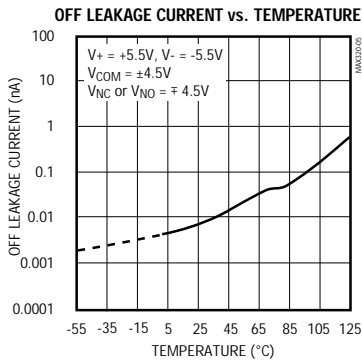
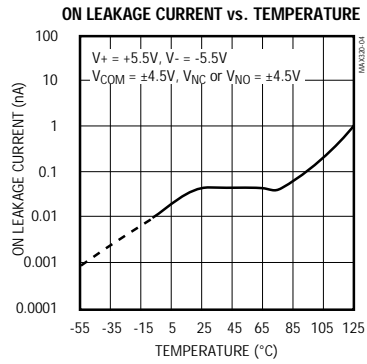
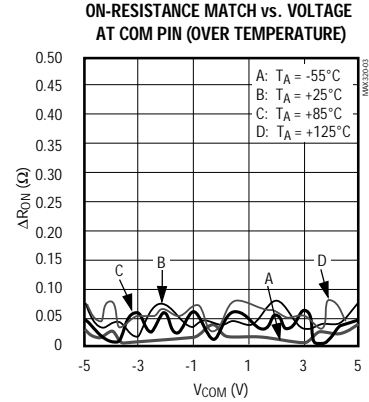
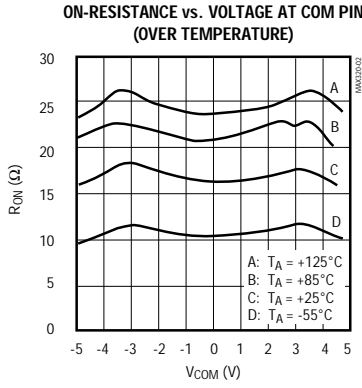
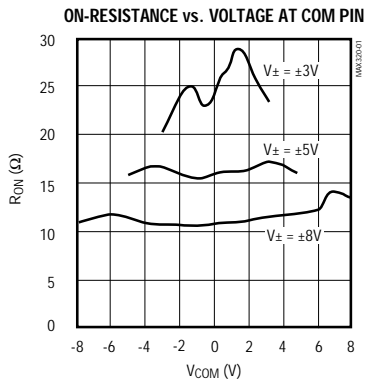

Precision, Dual-Supply, SPST Analog Switches

Pin Description

PIN	NAME	FUNCTION
1	NO1 (MAX320/MAX322)	Normally Open Analog Switch Terminal
	NC1 (MAX321)	Normally Closed Analog Switch Terminal
2, 6	COM1, COM2	Analog Switch Common Terminals
3, 7	IN2, IN1	Logic Inputs
4	V-	Negative Supply
5	NO2 (MAX320)	Normally Open Analog Switch Terminal
	NC2 (MAX321/MAX322)	Normally Closed Analog Switch Terminal
8	V+	Positive Supply

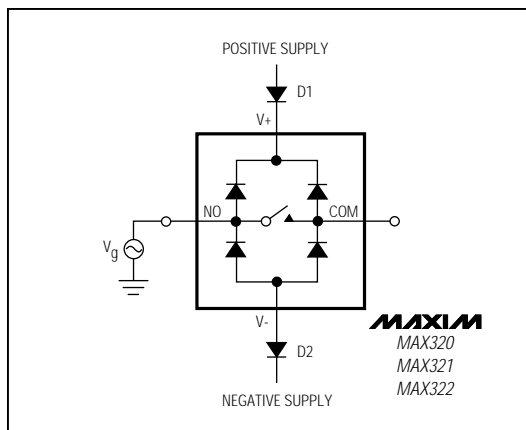

Figure 1. Overvoltage Protection Using Two External Blocking Diodes

Applications Information

Logic Levels

Calculate the logic thresholds typically as follows: $V_{IH} = (V_+ - 1.5V)$ and $V_{IL} = (V_+ - 2.5V)$.

Power-supply consumption is minimized when IN1 and IN2 are driven with logic-high levels equal to V_+ and logic-low levels well below the calculated V_{IL} of $(V_+ - 2.5V)$. IN1 and IN2 can be driven to V_- without damage.

Analog Signal Levels

Analog signals that range over the entire supply voltage (V_- to V_+) can be switched, with very little change in on-resistance over the entire voltage range (see *Typical Operating Characteristics*). All switches are bidirectional, so NO_, NC_, and COM_ pins can be used as either inputs or outputs.

Power-Supply Sequencing and Overvoltage Protection

Do not exceed the absolute maximum ratings, because stresses beyond the listed ratings may cause permanent damage to the devices.

Proper power-supply sequencing is recommended for all CMOS devices. Always apply V_+ , followed by V_- , before applying analog signals or logic inputs, especially if the analog or logic signals are not current-limited. If

this sequencing is not possible, and if the analog or logic inputs are not current-limited to $<30mA$, add two small signal diodes (D1, D2) as shown in Figure 1. Adding protection diodes reduces the analog signal range to a diode drop (about 0.7V) below V_+ for D1, and a diode drop above V_- for D2. Leakage is not affected by adding the diodes. On-resistance increases by a small amount at low supply voltages. Maximum supply voltage (V_- to V_+) must not exceed 17V.

Adding protection diode D1 causes the logic thresholds to be shifted relative to the positive power-supply rail. This can be significant when low positive supply voltages (+5V or less) are used. Driving IN1 and IN2 all the way to the supply rails (i.e., to a diode drop higher than the V_+ pin or a diode drop lower than the V_- pin) is always acceptable.

The protection diodes D1 and D2 also protect against some overvoltage situations. With the circuit of Figure 1, if the supply voltage is below the absolute maximum rating and if a fault voltage up to the absolute maximum rating is applied to an analog signal pin, no damage will result. For example, with $\pm 5V$ supplies, analog signals up to $\pm 8.5V$ will not damage the circuit of Figure 1. If only a single fault signal is present, the fault voltage can rise to +12V or to -12V without damage.

MAX320/MAX321/MAX322

Precision, Dual-Supply, SPST Analog Switches

Test Circuits/Timing Diagrams

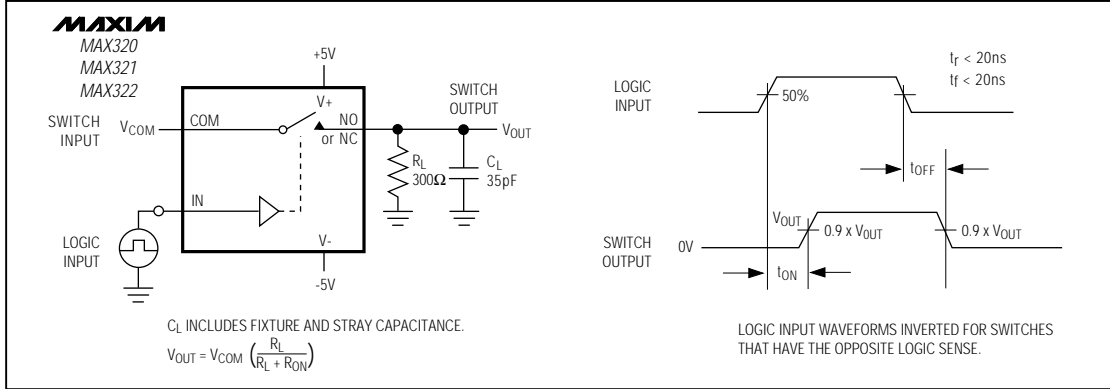

Figure 2. Switching Time

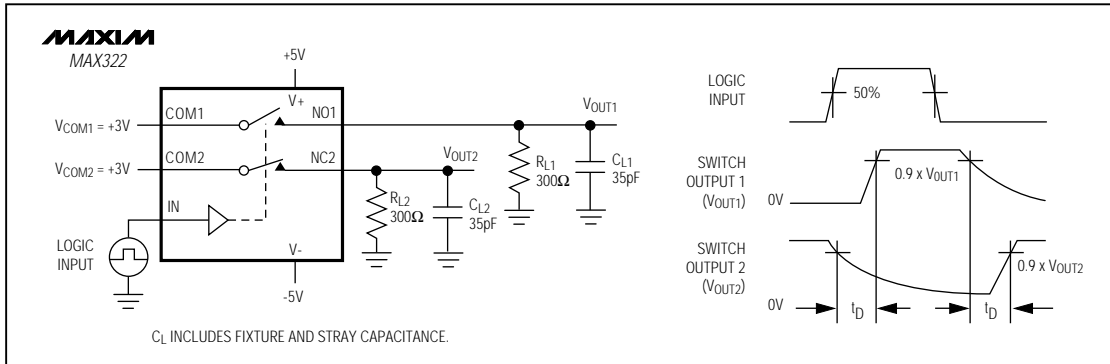

Figure 3. Break-Before-Make Interval (MAX322 only)

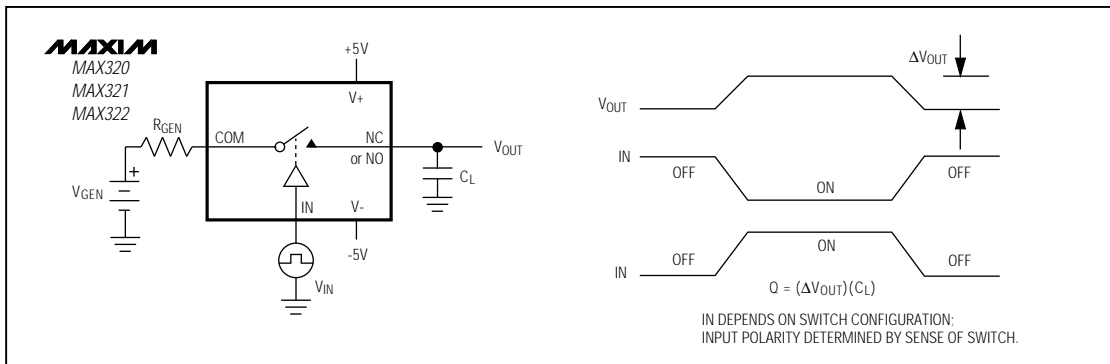

Figure 4. Charge Injection

Precision, Dual-Supply, SPST Analog Switches

Test Circuits/Timing Diagrams (continued)

MAX320/MAX321/MAX322

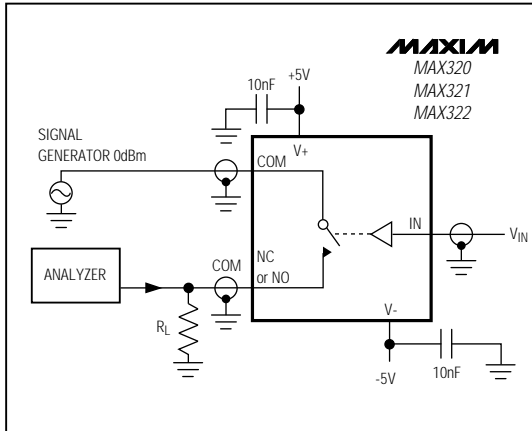

Figure 5. Off Isolation

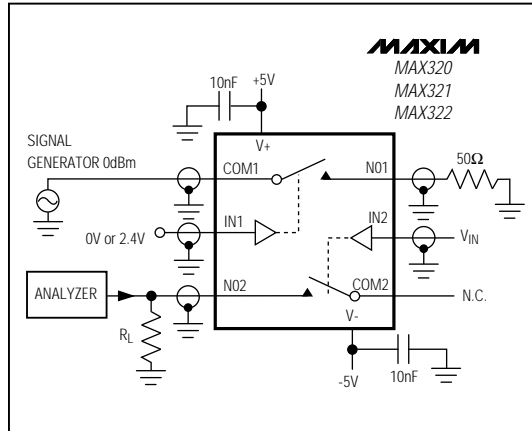

Figure 6. Crosstalk

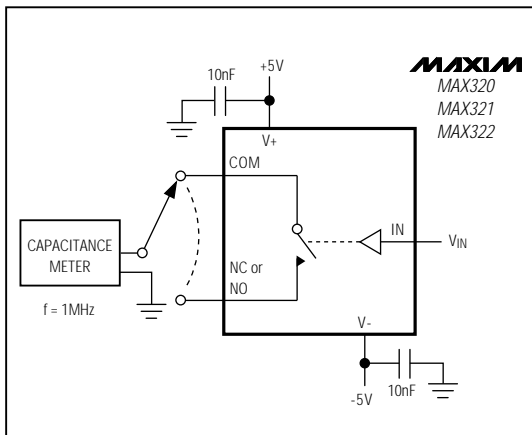

Figure 7. Channel-Off Capacitance

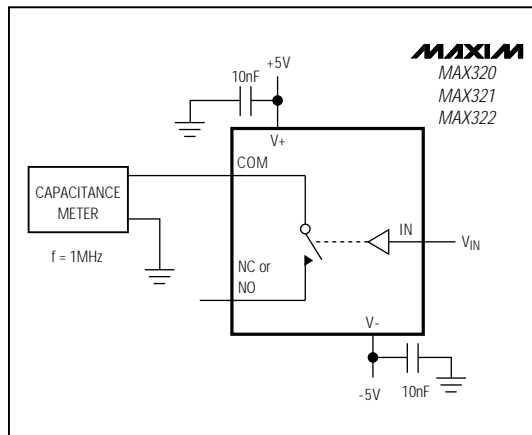

Figure 8. Channel-On Capacitance

Precision, Dual-Supply, SPST Analog Switches

Ordering Information (continued)

PART	TEMP. RANGE	PIN-PACKAGE
MAX321 CPA	0°C to +70°C	8 Plastic DIP
MAX321CSA	0°C to +70°C	8 SO
MAX321CUA	0°C to +70°C	8 μ MAX
MAX321C/D	0°C to +70°C	Dice*
MAX321EPA	-40°C to +85°C	8 Plastic DIP
MAX321ESA	-40°C to +85°C	8 SO
MAX321EJA	-40°C to +85°C	8 CERDIP**
MAX321MJA	-55°C to +125°C	8 CERDIP**
MAX322 CPA	0°C to +70°C	8 Plastic DIP
MAX322CSA	0°C to +70°C	8 SO
MAX322CUA	0°C to +70°C	8 μ MAX
MAX322C/D	0°C to +70°C	Dice*
MAX322EPA	-40°C to +85°C	8 Plastic DIP
MAX322ESA	-40°C to +85°C	8 SO
MAX322EJA	-40°C to +85°C	8 CERDIP**
MAX322MJA	-55°C to +125°C	8 CERDIP**

* Contact factory for dice specifications.

** Contact factory for availability.

Chip Topography

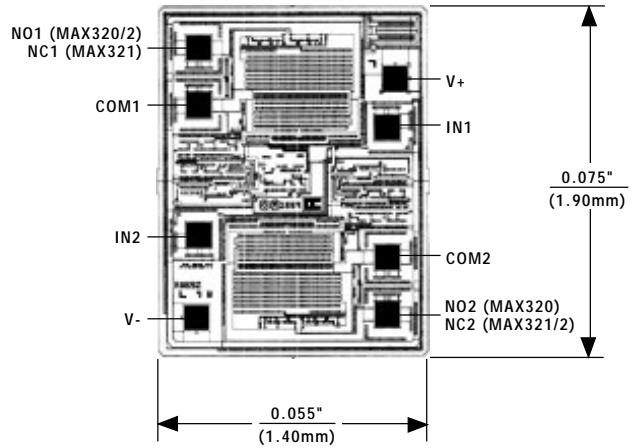

TRANSISTOR COUNT: 91
SUBSTRATE CONNECTED TO V+

Package Information

DIM	INCHES		MILLIMETERS	
	MIN	MAX	MIN	MAX
A	0.036	0.044	0.91	1.11
A1	0.004	0.008	0.10	0.20
B	0.010	0.014	0.25	0.36
C	0.005	0.007	0.13	0.18
D	0.116	0.120	2.95	3.05
E	0.116	0.120	2.95	3.05
e	0.0256		0.65	
H	0.188	0.198	4.78	5.03
L	0.016	0.026	0.41	0.66
α	0°	6°	0°	6°

**8-PIN μ MAX
MICROMAX SMALL OUTLINE
PACKAGE**

Maxim cannot assume responsibility for use of any circuitry other than circuitry entirely embodied in a Maxim product. No circuit patent licenses are implied. Maxim reserves the right to change the circuitry and specifications without notice at any time.

8 Maxim Integrated Products, 120 San Gabriel Drive, Sunnyvale, CA 94086 (408) 737-7600

© 1994 Maxim Integrated Products

Printed USA

MAXIM is a registered trademark of Maxim Integrated Products.

X-ON Electronics

Largest Supplier of Electrical and Electronic Components

Click to view similar products for [Analogue Switch ICs category](#):

Click to view products by [Maxim manufacturer](#):

Other Similar products are found below :

[FSA3051TMX](#) [NLAS4684FCTCG](#) [NLAS5223BLMNR2G](#) [NLVAS4599DTT1G](#) [NLX2G66DMUTCG](#) [425541DB](#) [425528R](#) [099044FB](#)
[NLAS5123MNR2G](#) [PI5A4157CEX](#) [NLAS4717EPFCT1G](#) [PI5A3167CCEX](#) [SLAS3158MNR2G](#) [PI5A392AQE](#) [PI5A4157ZUEX](#)
[PI5A3166TAEX](#) [FSA634UCX](#) [XS3A1T3157GMX](#) [TC4066BP\(N,F\)](#) [DG302BDJ-E3](#) [PI5A100QEX](#) [HV2605FG-G](#) [HV2301FG-G](#)
[RS2117YUTQK10](#) [RS2118YUTQK10](#) [RS2227XUTQK10](#) [ADG452BRZ-REEL7](#) [MAX4066ESD+](#) [MAX391CPE+](#) [MAX4730EXT+T](#)
[MAX314CPE+](#) [BU4066BCFV-E2](#) [MAX313CPE+](#) [BU4S66G2-TR](#) [NLASB3157MTR2G](#) [TS3A4751PWR](#) [NLAS4157DFT2G](#)
[NLAST4599DFT2G](#) [NLAST4599DTT1G](#) [DG419LDY+T](#) [DG300BDJ-E3](#) [DG2503DB-T2-GE1](#) [TC4W53FU\(TE12L,F\)](#) [HV2201FG-G](#)
[74HC2G66DC.125](#) [DG3257DN-T1-GE4](#) [ADG619BRMZ-REEL](#) [ADG1611BRUZ-REEL7](#) [DG2535EDQ-T1-GE3](#) [LTC201ACN#PBF](#)