



# Low-Noise, Fibre Channel Transimpedance Amplifiers

## General Description

The MAX3275/MAX3277 transimpedance amplifiers provide a compact low-power solution for communication up to 2.125Gbps. They feature 300nA input-referred noise at 2.1GHz bandwidth (BW) with 0.85pF input capacitance. The parts also have 2mAp-p AC input overload.

The MAX3277 is identical to the MAX3275, but with the output polarities inverted for optimum packaging flexibility. Both parts operate from a single 3.3V supply and consume only 83mW. The MAX3275/MAX3277 are compact 24mil x 47mil die and require no external compensation capacitor. A space-saving filter connection is provided for positive bias to the photodiode through an on-chip 600Ω resistor to V<sub>CC</sub>. These features allow easy assembly into a TO-46 or TO-56 header with a photodiode.

The MAX3275/MAX3277 and MAX3274 limiting amplifiers provide a two-chip solution for dual-rate, fibre channel receiver applications.

## Applications

Dual-Rate Fibre Channel Optical Receivers  
Gigabit Ethernet Optical Receivers

## Features

- ◆ Up to 2.125Gbps (NRZ) Data Rates
- ◆ 7psp-p Deterministic Jitter for <math><100\mu\text{A}</math>-p Input Current
- ◆ 300nA<sub>RMS</sub> Input-Referred Noise at 2.1GHz Bandwidth
- ◆ 25mA Supply Current at +3.3V
- ◆ 2.3GHz Small-Signal Bandwidth
- ◆ 2.0mAp-p AC Overload
- ◆ Die Size: 24mil x 47mil

## Ordering Information

PART	TEMP RANGE	PIN-PACKAGE
MAX3275U/D	0°C to +85°C	Dice*
MAX3277U/D	0°C to +85°C	Dice*

\*Dice are guaranteed to operate from 0°C to +85°C, but are tested only at T<sub>A</sub> = +25°C.

MAX3275/MAX3277

## Typical Application Circuit

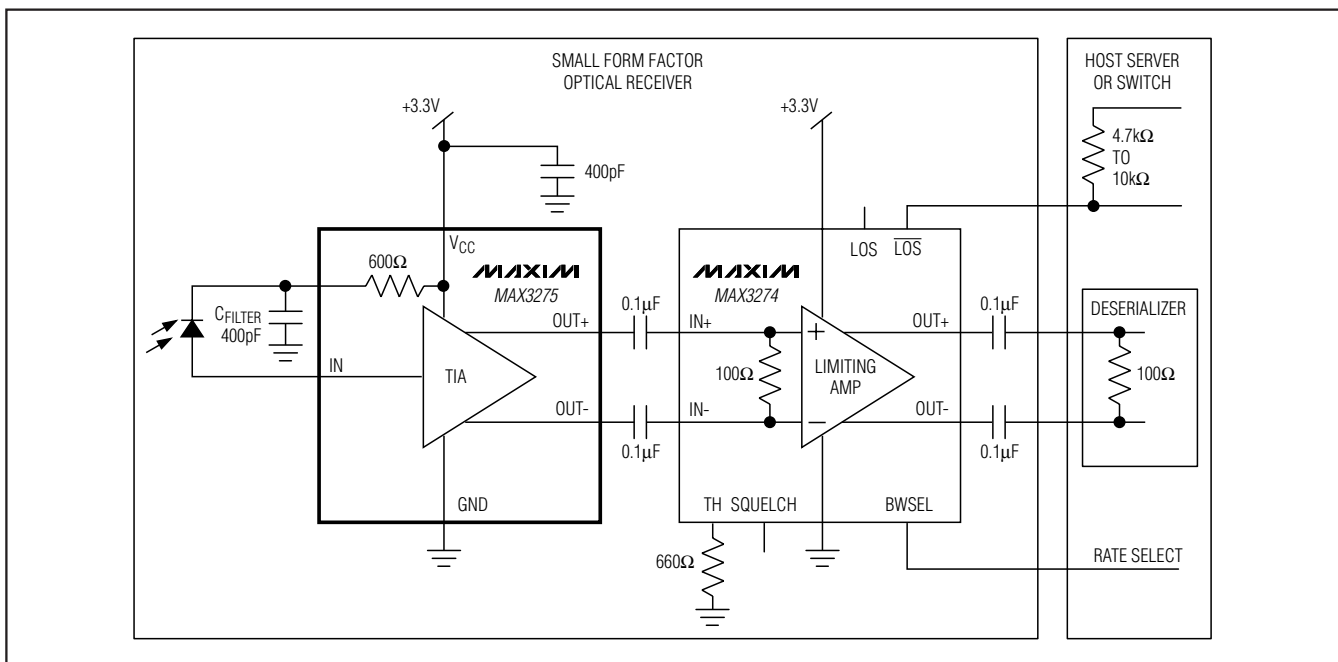

# Low-Noise, Fibre Channel Transimpedance Amplifiers

## ABSOLUTE MAXIMUM RATINGS

Power-Supply Voltage ( $V_{CC}$ )	-0.5V to +4.0V
Continuous CML Output Current (OUT+, OUT-)	-25mA to +25mA
Continuous Input Current (IN)	-4mA to +4mA
Continuous Input Current (FILTER)	-8mA to +8mA

Operating Junction Temperature Range ( $T_J$ )	-55°C to +150°C
Storage Ambient Temperature Range ( $T_{STG}$ )	-55°C to +150°C
Die Attach Temperature	+400°C

Stresses beyond those listed under "Absolute Maximum Ratings" may cause permanent damage to the device. These are stress ratings only, and functional operation of the device at these or any other conditions beyond those indicated in the operational sections of the specifications is not implied. Exposure to absolute maximum rating conditions for extended periods may affect device reliability.

## ELECTRICAL CHARACTERISTICS

( $V_{CC} = +3.0V$  to  $+3.6V$ ,  $T_A = 0^\circ C$  to  $+85^\circ C$ . Typical values are at  $V_{CC} = +3.3V$ , source capacitance ( $C_{IN}$ ) =  $0.85pF$ ,  $T_A = +25^\circ C$ , unless otherwise noted.) (Notes 1, 2)

PARAMETER	SYMBOL	CONDITIONS	MIN	TYP	MAX	UNITS
Supply Current	$I_{CC}$	Including output termination current		25	41	mA
Small-Signal Bandwidth	BW	-3dB, $C_{IN} = 0.6pF$ (Note 3)	2.0	2.7	3.3	GHz
		-3dB, $C_{IN} = 0.85pF$ (Note 3)	1.7	2.3	2.7	
Low-Frequency Cutoff		-3dB, input current = $40\mu A$ (Note 3)		65		kHz
Input Bias Voltage					1.0	V
Input Resistance				40		$\Omega$
Input-Referred Noise	$I_N$	$C_{IN} = 0.6pF$ , BW = 0.8GHz (Notes 3, 4)		185	250	nARMS
		$C_{IN} = 0.6pF$ , BW = 1.6GHz (Notes 3, 4)		245	350	
		$C_{IN} = 0.6pF$ , BW = 2.1GHz (Notes 3, 4)		275	380	
		$C_{IN} = 0.85pF$ , BW = 0.8GHz (Notes 3, 4)		193	275	
		$C_{IN} = 0.85pF$ , BW = 1.6GHz (Notes 3, 4)		272	400	
		$C_{IN} = 0.85pF$ , BW = 2.1GHz (Notes 3, 4)		300	430	
AC Input Overload		(Notes 3, 5)	2			mAp-p
DC Input Overload		(Note 5)	1			mA
Filter Resistance		P-P	510	600	690	$\Omega$
Output Resistance (OUT+, OUT-)		Single-ended	42.5	50	57.5	$\Omega$
Deterministic Jitter	DJ	$1mAp-p < \text{input} < 2mAp-p$ (Notes 3, 6, 7)		15	40	psp-p
		$100\mu Ap-p < \text{input} \leq 1mAp-p$ (Notes 3, 6, 7)		15	31	
		$10\mu Ap-p < \text{input} \leq 100\mu Ap-p$ (Notes 3, 6, 7)		7	16	
Transimpedance		Differential output	2.8	3.3	3.8	$k\Omega$
Transimpedance Linear Range		$0.95 < \text{linearity} < 1.05$ (Note 8)	50			$\mu Ap-p$
Data Output Swing		Input $> 100\mu Ap-p$ (Note 9)	220	300	500	mVp-p
Output Data-Transition Time		Input $> 200\mu Ap-p$ , 20% to 80% rise/fall time (Notes 3, 10)		90	140	ps
Output Return Loss		Freq $\leq 1GHz$		15		dB
		$1GHz < \text{freq} \leq 2GHz$		10		
Power-Supply Rejection	PSR	$f < 1MHz$ (Note 11)		40		dB
		$1MHz \leq f < 10MHz$ (Note 11)		34		

# Low-Noise, Fibre Channel Transimpedance Amplifiers

MAX3275/MAX3277

## ELECTRICAL CHARACTERISTICS (continued)

( $V_{CC} = +3.0V$  to  $+3.6V$ ,  $T_A = 0^\circ C$  to  $+85^\circ C$ . Typical values are at  $V_{CC} = +3.3V$ , source capacitance ( $C_{IN}$ ) =  $0.85pF$ ,  $T_A = +25^\circ C$ , unless otherwise noted.) (Notes 1, 2)

- Note 1:** Die parameters are production tested at room temperature only, but are guaranteed by design and characterization from  $0^\circ C$  to  $+85^\circ C$ .
- Note 2:** Source capacitance represents the total capacitance at the IN pad during characterization of the noise and bandwidth parameters.
- Note 3:** Guaranteed by design and characterization.
- Note 4:** Measured using an RF-power meter with no pattern applied at the input. The TIA output is bandwidth limited for measurement using a 4th-order Bessel Thompson filter. The -3dB frequency of the filter matches the frequency (0.8GHz, 1.6GHz, or 2.1GHz) for the specified noise BW.
- Note 5:** DC offset and deterministic jitter may exceed specification if AC or DC overload conditions are exceeded.
- Note 6:** Using fibre channel K28.5± pattern. The input bandwidth is limited to  $0.75 \times (2.125Gbps)$  by a 4th-order Bessel Thompson filter. Measured differentially across an AC-coupled  $100\Omega$  external load.
- Note 7:** K28.5± pattern: (00111110101100000101).
- Note 8:** Gain may vary  $\pm 5\%$  relative to reference measured with  $30\mu A_{p-p}$  input.
- Note 9:** Production tested with  $1m A_{p-p}$  input.
- Note 10:** Using a K28.7 (0011111000) pattern. Measured differentially across an AC-coupled  $100\Omega$  external load.
- Note 11:** Power-supply rejection  $PSR = -20\log(\Delta V_{OUT}/\Delta V_{CC})$ , where  $\Delta V_{OUT}$  is the differential output voltage and  $\Delta V_{CC}$  is the noise on  $V_{CC}$ .

## Typical Operating Characteristics

( $V_{CC} = +3.3V$ ,  $C_{IN} = 0.85pF$ ,  $T_A = +25^\circ C$ , unless otherwise noted.)

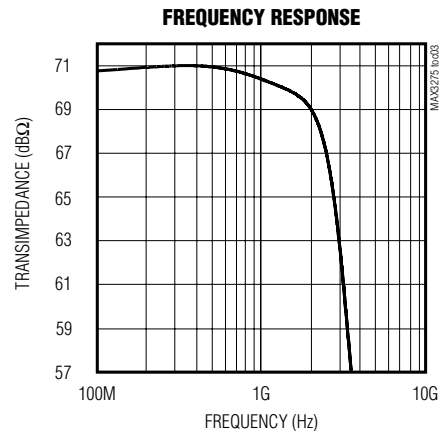
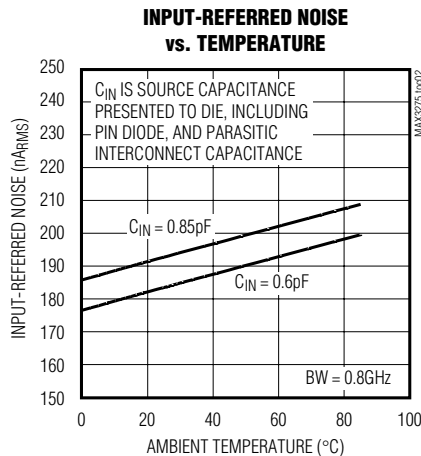
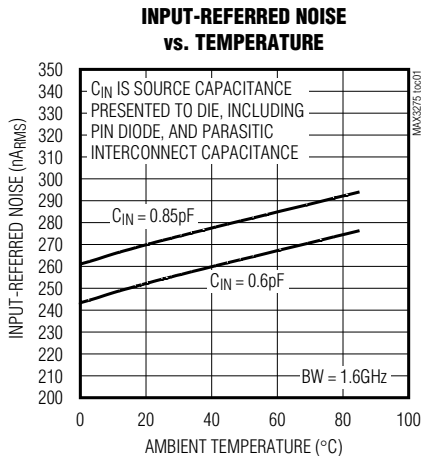

# Low-Noise, Fibre Channel Transimpedance Amplifiers

## Typical Operating Characteristics (continued)

( $V_{CC} = +3.3V$ ,  $C_{IN} = 0.85pF$ ,  $T_A = +25^\circ C$ , unless otherwise noted.)

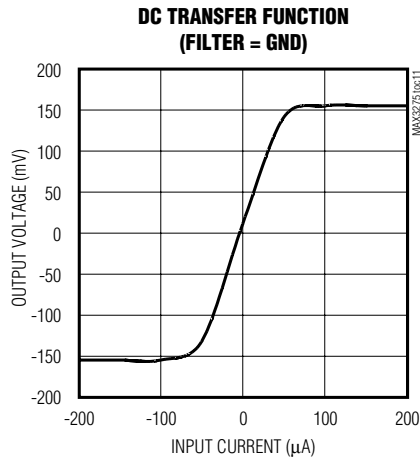
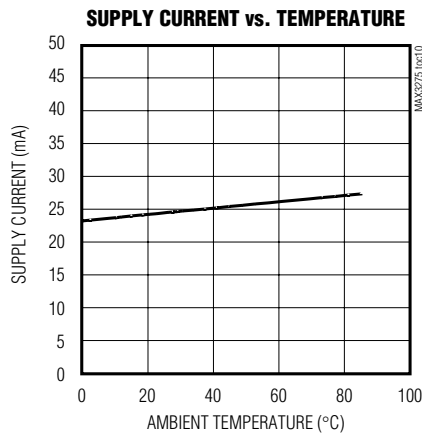
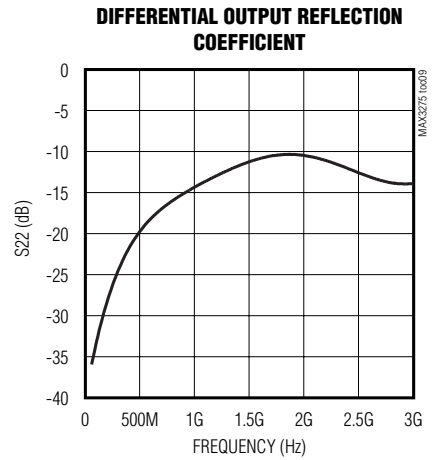
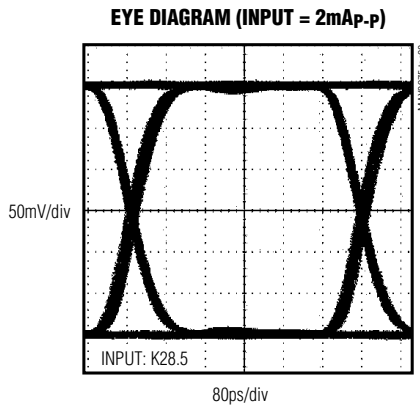
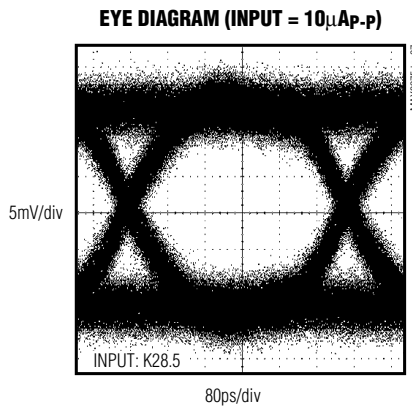
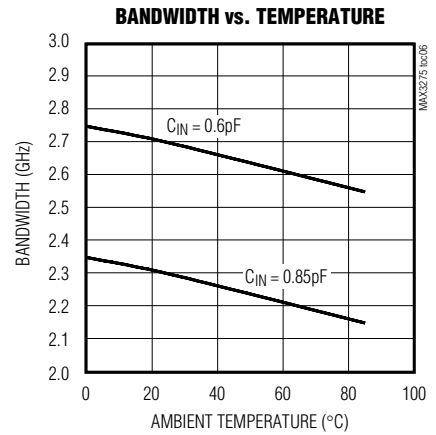
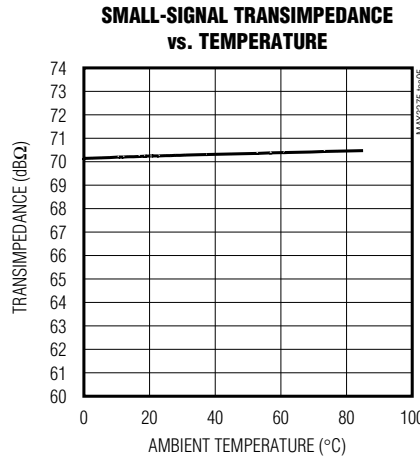
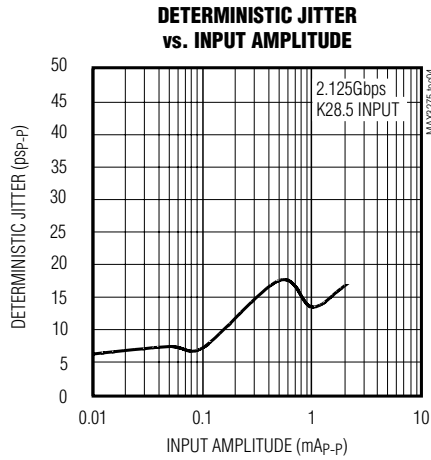

# Low-Noise, Fibre Channel Transimpedance Amplifiers

## Pad Description

MAX3275/MAX3277

MAX3275 BOND PAD	MAX3277 BOND PAD	NAME	FUNCTION
1, 9	1, 9	V <sub>CC</sub>	Supply Voltage
2, 5	2, 5	GND	Circuit Ground
3	4	OUT-	Inverting Data Output. Current flowing into IN causes the voltage at OUT- to decrease.
4	3	OUT+	Noninverting Data Output. Current flowing into IN causes the voltage at OUT+ to increase.
6	6	N.C.	No Connection. Not internally connected.
7	7	FILTER	Provides bias voltage for the photodiode through a 600Ω resistor to V <sub>CC</sub> . When grounded, this pin disables the DC cancellation amplifier to allow a DC path from IN to OUT+ and OUT- for testing.
8	8	IN	TIA Input. Signal current from photodiode flows into this pin.

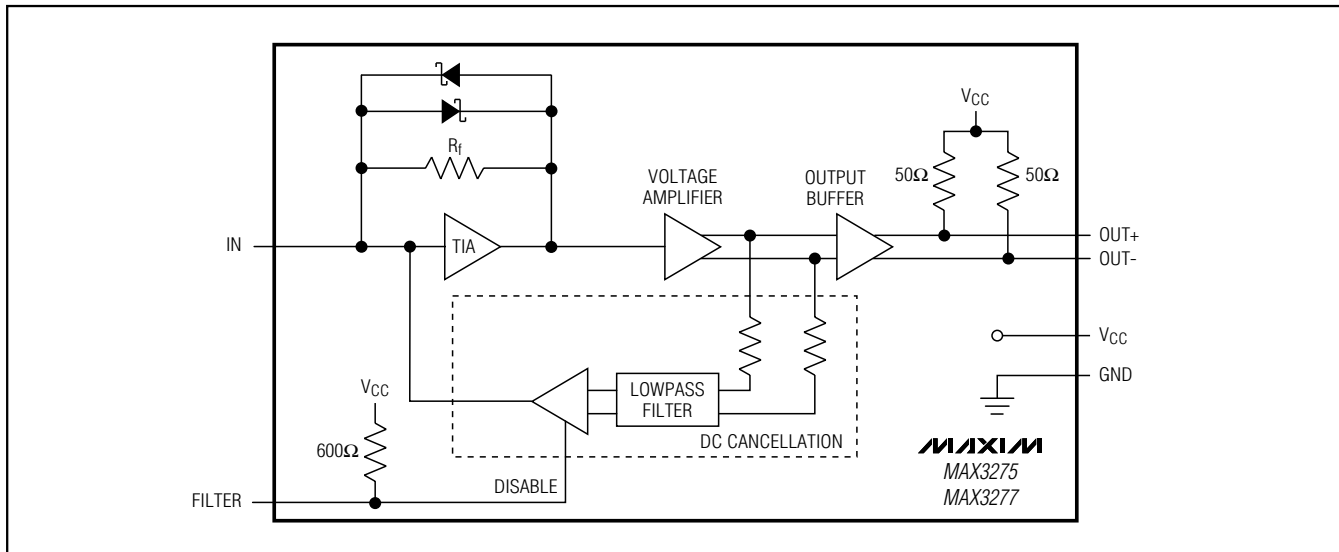

Figure 1. Functional Diagram

### Detailed Description

The MAX3275/MAX3277 are transimpedance amplifiers designed for up to 2.125Gbps fibre channel applications. A functional diagram of the MAX3275/MAX3277 is shown in Figure 1. The MAX3275/MAX3277 comprises a transimpedance amplifier stage, a voltage amplifier stage, an output buffer, and a direct-current feedback cancellation circuit.

### Transimpedance Amplifier Stage

The signal current at the input flows into the summing node of a high-gain amplifier. Shunt feedback through the resistor R<sub>f</sub> converts this current to a voltage. In parallel with the feedback are two back-to-back Schottky diodes that clamp the output signal for large input currents as shown in Figure 2.

### Voltage Amplifier Stage

The voltage amplifier stage provides gain and converts the single-ended input to differential outputs.

# Low-Noise, Fibre Channel Transimpedance Amplifiers

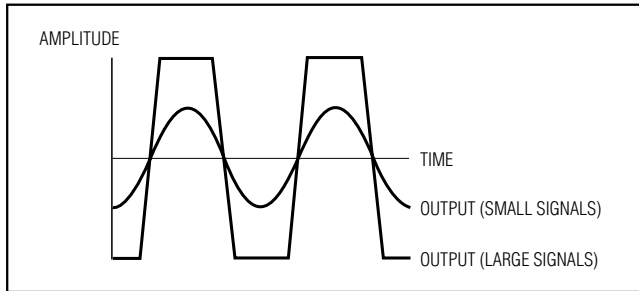

Figure 2. MAX3275/MAX3277 Limited Output

### Output Buffer

The output buffer provides a reverse-terminated voltage output. The buffer is designed to drive a 100Ω differential load between OUT+ and OUT-. The output current is divided between internal 50Ω resistors and the external load resistor.

For optimum supply-noise rejection, the MAX3275/MAX3277 should be terminated with a differential load. If a single-ended output is required, the unused output should be terminated in a similar manner. The MAX3275/MAX3277 will not drive a DC-coupled, 50Ω grounded load; however, it will drive a compatible 50Ω CML input.

### DC Cancellation Circuit

The direct-current (DC) cancellation circuit uses low-frequency feedback to remove the DC component of the input signal (Figure 3). This feature centers the input signal within the transimpedance amplifier's linear range, thereby reducing pulse-width distortion caused by large input signals. Pulse-width distortion in small signals will not be corrected.

The DC cancellation circuit is internally compensated and therefore does not require external capacitors. This circuit minimizes pulse-width distortion for data sequences that exhibit a 50% mark density and 8b/10b coding. A mark density significantly different from 50% will cause the MAX3275/MAX3277 to generate pulse-width distortion.

DC cancellation current is drawn from the input and creates noise. For low-level signals with little or no DC component, the added noise is insignificant.

## Applications Information

### Optical Power Relations

Many of the MAX3275/MAX3277 specifications relate to the input signal amplitude. When working with optical receivers, the input is sometimes expressed in terms of

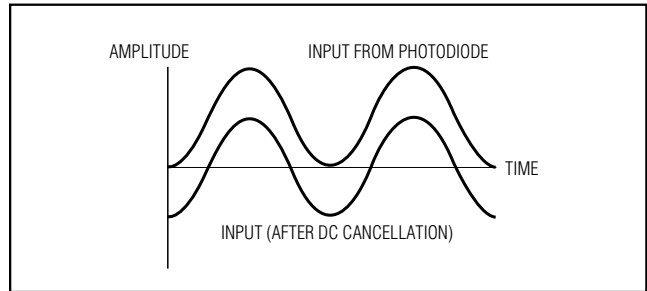

Figure 3. DC Cancellation Effect on Input

average optical power and extinction ratio. Figure 4 and Table 1 show relations that are helpful for converting optical power to input signal when designing with the MAX3275/MAX3277. (Refer to Application note HFAN-3.0.0 *Accurately Estimating Optical Receiver Sensitivity*.)

Table 1. Optical Power Relations

PARAMETER	SYMBOL	RELATION
Average Power	$P_{AVG}$	$P_{AVG} = (P_0 + P_1)/2$
Extinction Ratio	$r_e$	$r_e = P_1/P_0$
Optical Power of a 1	$P_1$	$P_1 = 2P_{AVG}(r_e)/(r_e + 1)$
Optical Power of a 0	$P_0$	$P_0 = 2P_{AVG}/(r_e + 1)$
Signal Amplitude	$P_{IN}$	$P_{IN} = P_1 - P_0$ $P_{IN} = 2P_{AVG}(r_e - 1)/(r_e + 1)$

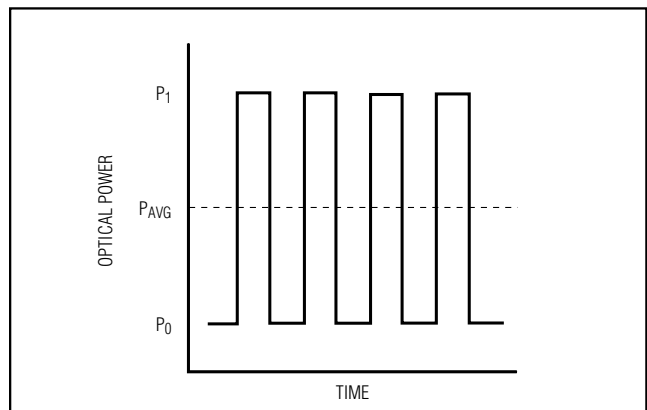

Figure 4. Optical Power Relations

### Optical Sensitivity Calculation

The input-referred RMS noise current ( $I_N$ ) of the MAX3275/MAX3277 generally determines the receiver

# Low-Noise, Fibre Channel Transimpedance Amplifiers

sensitivity. To obtain a system bit error rate (BER) of 1E-12, the signal-to-noise ratio must always exceed 14.1. The input sensitivity, expressed in average power, can be estimated as:

$$\text{Sensitivity} = 10 \log \left( \frac{14.1 I_N (r_e + 1) \times 1000}{2 \rho (r_e - 1)} \right) \text{dBm}$$

where  $\rho$  is the photodiode responsivity in A/W and  $I_N$  is RMS current in Amps.

### Input Optical Overload

The overload is the largest input that the MAX3275/MAX3277 accept while meeting specifications. The optical overload can be estimated in terms of average power with the following equation:

$$\text{Overload} = 10 \log \left( \frac{(2E-3) (r_e + 1) \times 1000}{2 \rho (r_e - 1)} \right) \text{dBm}$$

### Optical Linear Range

The MAX3275/MAX3277 have high gain, which limits the output when the input signal exceeds 50 $\mu$ A<sub>P-P</sub>. The MAX3275/MAX3277 operate in a linear range (10% linearity) for inputs not exceeding:

$$\text{Linear Range} = 10 \log \left( \frac{(50E-6) (r_e + 1) \times 1000}{2 \rho (r_e - 1)} \right) \text{dBm}$$

### Layout Considerations

Noise performance and bandwidth will be adversely affected by capacitance at the IN pad. Minimize capacitance on this pad and select a low-capacitance photodiode. Assembling the MAX3275/MAX3277 in die

form using chip and wire technology provides the best possible performance. Figure 5 shows a suggested layout for a TO header for the MAX3275/MAX3277. Special care should be taken to ensure that ESD at IN does not exceed 500V.

### Photodiode Filter

Supply voltage noise at the cathode of the photodiode produces a current  $I = C_{PD} \Delta V / \Delta t$ , which reduces the receiver sensitivity ( $C_{PD}$  is the photodiode capacitance). The filter resistor of the MAX3275/MAX3277, combined with an external capacitor, can be used to reduce this noise (see the *Typical Application Circuit*). Current generated by supply noise voltage is divided between  $C_{FILTER}$  and  $C_{PD}$ . The input noise current due to supply noise is (assuming the filter capacitor is much larger than the photodiode capacitance):

$$I_{NOISE} = (V_{NOISE})(C_{PD}) / (R_{FILTER})(C_{FILTER})$$

If the amount of tolerable noise is known, the filter capacitor can be easily selected:

$$C_{FILTER} = (V_{NOISE})(C_{PD}) / (R_{FILTER})(I_{NOISE})$$

For example, with maximum noise voltage = 100mV<sub>P-P</sub>,  $C_{PD} = 0.85\text{pF}$ ,  $R_{FILTER} = 600\Omega$ , and  $I_{NOISE}$  selected to be 350nA:

$$C_{FILTER} = (100\text{mV})(0.85\text{pF}) / (600\Omega)(350\text{nA}) = 400\text{pF}$$

### Wire Bonding

For high-current density and reliable operation, the MAX3275/MAX3277 use gold metalization. Connections to the die should be made with gold wire only, using ball-bonding techniques. Wedge bonding is not recommended. Die thickness is typically 15 mils (0.4mm).

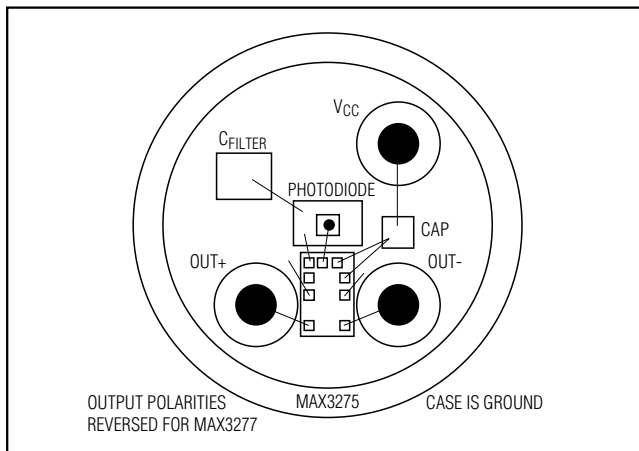

Figure 5. Suggested Layout for TO-46 Header

### Pad Coordinates

PAD#	COORDINATES ( $\mu$ m)
1	16, 39
2	16, 372
3	16, 806
4	358, 806
5	358, 341
6	358, 36
7	362, -116
8	250, -116
9	138, -116

# Low-Noise, Fibre Channel Transimpedance Amplifiers

MAX3275/MAX3277

## Chip Topographies

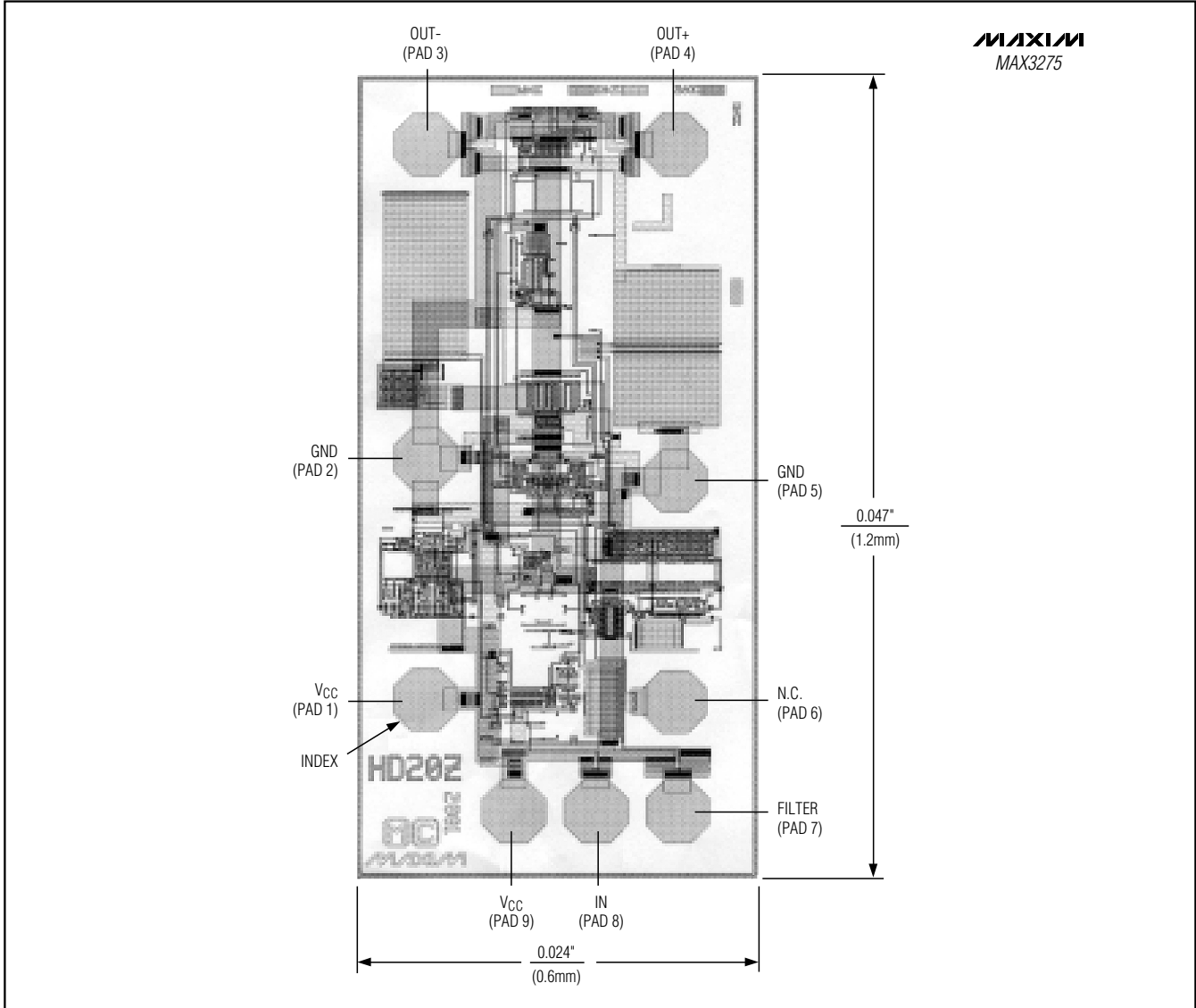



# Low-Noise, Fibre Channel Transimpedance Amplifiers

## Chip Topographies (continued)

**MAX3275/MAX3277**

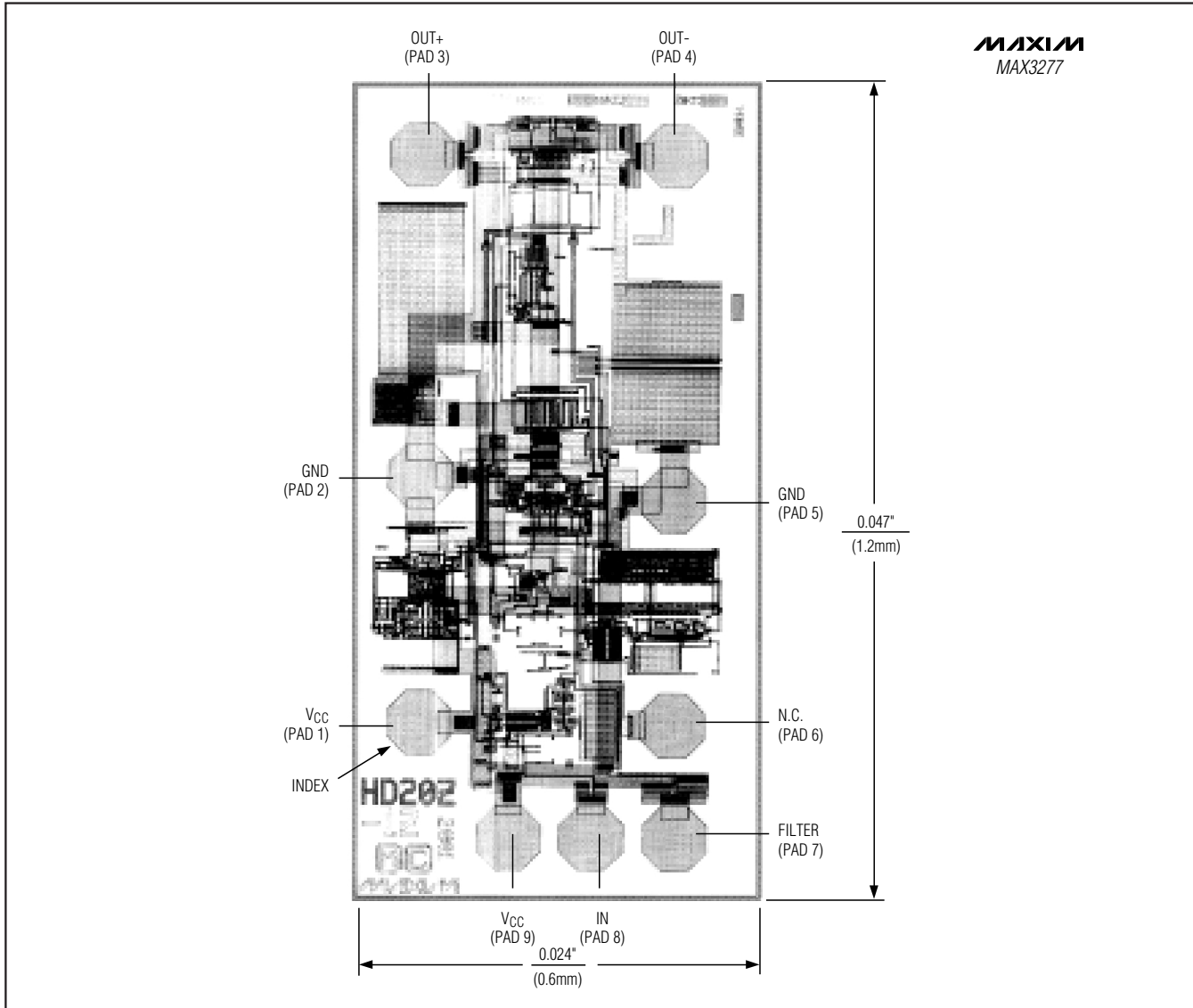

### Chip Information

TRANSISTOR COUNT: 301  
 SUBSTRATE: ISOLATED  
 PROCESS: SiGe BIPOLAR

*Maxim cannot assume responsibility for use of any circuitry other than circuitry entirely embodied in a Maxim product. No circuit patent licenses are implied. Maxim reserves the right to change the circuitry and specifications without notice at any time.*

**Maxim Integrated Products, 120 San Gabriel Drive, Sunnyvale, CA 94086 408-737-7600** \_\_\_\_\_ **9**

## X-ON Electronics

Largest Supplier of Electrical and Electronic Components

*Click to view similar products for [Transimpedance Amplifiers](#) category:*

*Click to view products by [Maxim](#) manufacturer:*

Other Similar products are found below :

[HMC7590-SX](#) [AD8015ARZ](#) [AD8015ARZ-REEL7](#) [LTC6561HUF#PBF](#) [LTC6560HUD#WPBF](#) [OPA380AIDGKTG4](#) [OPA2380AIDGKR](#)  
[OPA1S2385IDRCR](#) [OPA2380AIDGKT](#) [OPA2381AIDGKT](#) [OPA2381AIDRBT](#) [OPA380AIDG4](#) [OPA857IRGTT](#) [OPA858IDSGR](#)  
[OPA858IDSGT](#) [MAX3658AETA+T](#) [ACF2101BU](#) [IVC102U/2K5](#) [OPA856IDSGR](#)