



Dual Bidirectional Low-Level Translator in μ DFN

MAX3397E

General Description

The MAX3397E ± 15 kV ESD-protected bidirectional level translator provides level shifting for data transfer in a multivoltage system. Externally applied voltages, V_{CC} and V_L , set the logic levels on either side of the device. A logic-low signal present on the V_L side of the device appears as a logic-low signal on the V_{CC} side of the device, and vice versa. The MAX3397E utilizes a transmission-gate-based design to allow data translation in either direction ($V_L \leftrightarrow V_{CC}$) on any single data line. The MAX3397E accepts V_L from +1.2V to +5.5V and V_{CC} from +1.65V to +5.5V, making the device ideal for data transfer between low-voltage ASICs/PLDs and higher voltage systems.

The MAX3397E features a shutdown mode that reduces supply current to less than $1\mu\text{A}$, thermal short-circuit protection, and ± 15 kV ESD protection on the V_{CC} side for greater protection in applications that route signals externally. The MAX3397E operates at a guaranteed data rate of 8Mbps over the entire specified operating voltage range. Within specific voltage domains, higher data rates are possible. See the *Timing Characteristics* table.

The MAX3397E is available in an 8-pin μ DFN package and specified over the extended -40°C to $+85^\circ\text{C}$ operating temperature range.

Applications

Cell Phones, MP3 Players
Telecommunications Equipment
SPI™, MICROWIRE™, and I²C Level Translation
Portable POS Systems, Smart Card Readers
Low-Cost Serial Interfaces, GPS

SPI is a trademark of Motorola, Inc.
MICROWIRE is a trademark of National Semiconductor Corp.

Typical Application Circuit appears at end of data sheet.

Features

- ◆ Bidirectional Level Translation
- ◆ Guaranteed Data Rate
 - 8Mbps ($+1.2\text{V} \leq V_L \leq V_{CC} \leq +5.5\text{V}$)
 - 16Mbps ($+1.8\text{V} \leq V_L \leq V_{CC} \leq +3.3\text{V}$)
- ◆ Extended ESD Protection on the I/O V_{CC} Lines
 - $\pm 15\text{kV}$ Human Body Model
 - $\pm 15\text{kV}$ Air-Gap Discharge per IEC 61000-4-2
 - $\pm 8\text{kV}$ Contact Discharge per IEC 61000-4-2
- ◆ Enable/Shutdown
- ◆ Ultra-Low $1\mu\text{A}$ Supply Current in Shutdown Mode
- ◆ 8-Pin μ DFN Package

Ordering Information

PART	TEMP RANGE	PIN-PACKAGE	TOP MARK	PKG CODE
MAX3397EELA+	-40°C to $+85^\circ\text{C}$	8 μ DFN (2mm x 2mm)	ABU	L822-1

+Denotes a lead-free package.

Pin Configuration

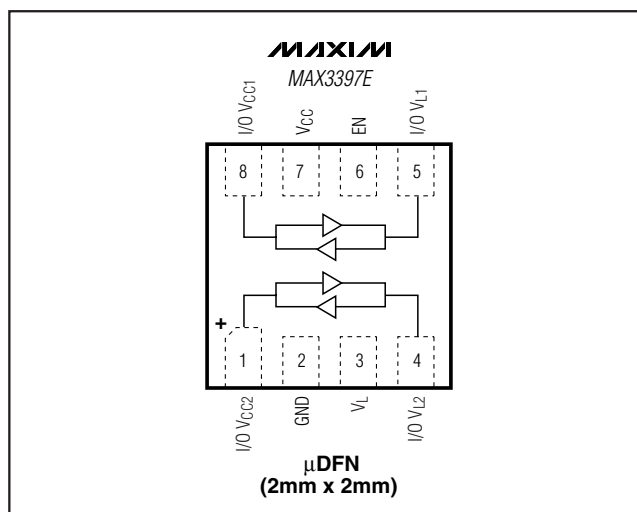

Dual Bidirectional Low-Level Translator in μ DFN

ABSOLUTE MAXIMUM RATINGS

(All voltages referenced to GND.)

V_{CC} , V_L	-0.3V to +6V
I/O V_{CC}	-0.3V to ($V_{CC} + 0.3V$)
I/O V_L	-0.3V to ($V_L + 0.3V$)
EN	-0.3V to +6V
Short-Circuit Duration I/O V_L , I/O V_{CC} to GND	Continuous

Continuous Power Dissipation ($T_A = +70^\circ\text{C}$)

8-Pin μ DFN (derate 4.8mW/ $^\circ\text{C}$ above $+70^\circ\text{C}$)	381mW
Operating Temperature Range	-40°C to $+85^\circ\text{C}$
Storage Temperature Range	-65°C to $+150^\circ\text{C}$
Lead Temperature (soldering, 10s)	$+300^\circ\text{C}$

Stresses beyond those listed under "Absolute Maximum Ratings" may cause permanent damage to the device. These are stress ratings only, and functional operation of the device at these or any other conditions beyond those indicated in the operational sections of the specifications is not implied. Exposure to absolute maximum rating conditions for extended periods may affect device reliability.

ELECTRICAL CHARACTERISTICS

($V_{CC} = +1.65V$ to $+5.5V$, $V_L = +1.2V$ to $5.5V$, I/O V_L , and I/O V_{CC} are unconnected, $T_A = T_{MIN}$ to T_{MAX} , unless otherwise noted. Typical values are at $V_{CC} = +3.3V$, $V_L = +1.8V$, $T_A = +25^\circ\text{C}$.) (Notes 1, 2)

PARAMETER	SYMBOL	CONDITIONS	MIN	TYP	MAX	UNITS
POWER SUPPLIES						
V_L Supply Range	V_L		1.2		5.5	V
V_{CC} Supply Range	V_{CC}		1.65		5.50	V
Supply Current from V_{CC}	I_{QVCC}			130	300	μA
Supply Current from V_L	I_{QVL}			1	10	μA
V_{CC} Shutdown-Mode Supply Current	$I_{SHUTDOWN-VCC}$	$T_A = +25^\circ\text{C}$, EN = GND		0.03	1	μA
V_L Shutdown-Mode Supply Current	$I_{SHUTDOWN-VL}$	$T_A = +25^\circ\text{C}$, EN = GND		0.03	1	μA
I/O V_L and I/O V_{CC} Shutdown-Mode Leakage Current	$I_{SHUTDOWN-LKG}$	$T_A = +25^\circ\text{C}$, EN = GND		0.02	1	μA
EN Input Leakage		$T_A = +25^\circ\text{C}$		0.02	1	μA
Tri-State Threshold Low	V_{TH_L}	V_{CC} falling (Note 3)			1.5	V
Tri-State Threshold High	V_{TH_H}	V_{CC} rising (Note 3)			1	V
ESD PROTECTION						
I/O V_{CC}		Human Body Model (Note 4)		± 15		kV
LOGIC-LEVEL THRESHOLDS						
I/O V_L Input-Voltage High	V_{IHL}		$V_L - 0.2$			V
I/O V_L Input-Voltage Low	V_{ILL}				0.15	V
I/O V_{CC} Input-Voltage High	V_{IHC}		$V_{CC} - 0.4$			V
I/O V_{CC} Input-Voltage Low	V_{ILC}				0.15	V
I/O V_L Output-Voltage High	V_{OHL}	I/O V_L source current = $20\mu\text{A}$, I/O $V_{CC} > V_{CC} - 0.4V$	$0.67 \times V_L$			V
I/O V_L Output-Voltage Low	V_{OLL}	I/O V_L sink current = 1mA , I/O $V_{CC} < 0.15V$			0.4	V

Dual Bidirectional Low-Level Translator in μ DFN

MAX3397E

ELECTRICAL CHARACTERISTICS (continued)

($V_{CC} = +1.65V$ to $+5.5V$, $V_L = +1.2V$ to $5.5V$, I/O $V_{L_}$, and I/O $V_{CC_}$ are unconnected, $T_A = T_{MIN}$ to T_{MAX} , unless otherwise noted. Typical values are at $V_{CC} = +3.3V$, $V_L = +1.8V$, $T_A = +25^\circ C$.) (Notes 1, 2)

PARAMETER	SYMBOL	CONDITIONS	MIN	TYP	MAX	UNITS
I/O $V_{CC_}$ Output-Voltage High	V_{OHC}	I/O $V_{CC_}$ source current = $20\mu A$, I/O $V_{L_} > V_L - 0.2V$	$0.67 \times$ V_{CC}			V
I/O $V_{CC_}$ Output-Voltage Low	V_{OLC}	I/O $V_{CC_}$ sink current = $1mA$, I/O $V_{L_} < 0.15V$			0.4	V
EN Input-Voltage High	V_{IH-EN}		$V_L -$ 0.2			V
EN Input-Voltage Low	V_{IL-EN}				0.15	V
RISE/FALL-TIME ACCELERATOR STAGE						
Transition-Detect Threshold		I/O V_{CC} side		0.8		V
		I/O V_L side		0.8		
Accelerator Pulse Duration		$V_L = 1.2V$, $V_{CC} = 1.65V$		27		ns
I/O V_L Output-Accelerator Source Impedance		$V_L = 1.2V$, $V_{CC} = 1.65V$		40		Ω
		$V_L = 5V$, $V_{CC} = 5V$		9		
I/O $V_{CC_}$ Output-Accelerator Source Impedance		$V_L = 1.2V$, $V_{CC} = 1.65V$		30		Ω
		$V_L = 5V$, $V_{CC} = 5V$		12		

TIMING CHARACTERISTICS

($V_{CC} = +1.65V$ to $+5.5V$, $V_L = +1.2V$ to $+5.5V$, $R_{LOAD} = 1M\Omega$, $C_{LOAD} = 15pF$, driver output impedance $\leq 50\Omega$, I/O test signal of Figure 1, $T_A = T_{MIN}$ to T_{MAX} , unless otherwise noted. Typical values are at $V_{CC} = +3.3V$, $V_L = +1.8V$, $T_A = +25^\circ C$.) (Notes 1, 2)

PARAMETER	SYMBOL	CONDITIONS	MIN	TYP	MAX	UNITS
+1.2V $\leq V_L \leq V_{CC} \leq +5.5V$						
I/O $V_{CC_}$ Rise Time	t_{RVCC}	Push-pull driving (Figure 1a)		7	25	ns
		Open-drain driving (Figure 1c)		170	400	
I/O $V_{CC_}$ Fall Time	t_{FVCC}	Push-pull driving (Figure 1a)		6	37	ns
		Open-drain driving (Figure 1c)		6	37	
I/O V_L Rise Time	t_{RVL}	Push-pull driving (Figure 1b)		8	30	ns
		Open-drain driving (Figure 1d)		180	400	
I/O V_L Fall Time	t_{FVL}	Push-pull driving (Figure 1b)		3	30	ns
		Open-drain driving (Figure 1d)		3	30	
Propagation Delay	$t_{PD-VL-VCC}$	Driving I/O $V_{L_}$	Push-pull driving (Figure 1a)	5	30	ns
			Open-drain driving (Figure 1c)	170	800	
	Driving I/O $V_{CC_}$	Push-pull driving (Figure 1b)	4	30		
		Open-drain driving (Figure 1d)	190	1000		
Channel-to-Channel Skew	t_{SKEW}	Each translator equally loaded	Push-pull driving		20	ns
			Open-drain driving		50	
Maximum Data Rate		Push-pull driving	8			Mbps
		Open-drain driving	500			kbps

Dual Bidirectional Low-Level Translator in μ DFN

TIMING CHARACTERISTICS (continued)

($V_{CC} = +1.65V$ to $+5.5V$, $V_L = +1.2V$ to $+5.5V$, $R_{LOAD} = 1M\Omega$, $C_{LOAD} = 15pF$, driver output impedance $\leq 50\Omega$, I/O test signal of Figure 1, $T_A = T_{MIN}$ to T_{MAX} , unless otherwise noted. Typical values are at $V_{CC} = +3.3V$, $V_L = +1.8V$, $T_A = +25^\circ C$.) (Notes 1, 2)

PARAMETER	SYMBOL	CONDITIONS	MIN	TYP	MAX	UNITS
$+1.8V \leq V_L \leq V_{CC} \leq +3.3V$						
I/O V_{CC} _ Rise Time	t_{RVCC}	Figure 1a (Note 5)			15	ns
I/O V_{CC} _ Fall Time	t_{FVCC}	Figure 1a (Note 6)			15	ns
I/O V_L _ Rise Time	t_{RVL}	Figure 1b (Note 5)			15	ns
I/O V_L _ Fall Time	t_{FVL}	Figure 1b (Note 6)			15	ns
Propagation Delay	$t_{PD-VL-VCC}$	Driving I/O V_L _			15	ns
	$t_{PD-VCC-VL}$	Driving I/O V_{CC} _			15	
Channel-to-Channel Skew	t_{SKEW}	Each translator equally loaded			10	ns
Maximum Data Rate			16			Mbps

Note 1: All units are 100% production tested at $T_A = +25^\circ C$. Limits over the operating temperature range are guaranteed by design and not production tested.

Note 2: For normal operation, ensure $V_L < (V_{CC} + 0.3V)$.

Note 3: When V_{CC} is below V_L by more than the tri-state threshold, the device turns off its pullup resistors and I/O_ enters tri-state. The device is not in shutdown.

Note 4: To ensure maximum ESD protection, place a $1\mu F$ capacitor between V_{CC} and GND. See the *Typical Application Circuit*.

Note 5: 10% of input to 90% of output.

Note 6: 90% of input to 10% of output.

Typical Operating Characteristics

($V_{CC} = +3.3V$, $V_L = +1.8V$, $R_{LOAD} = 1M\Omega$, $C_{LOAD} = 15pF$, $T_A = +25^\circ C$, data rate = 8Mbps, unless otherwise noted.)

**V_L SUPPLY CURRENT vs. V_{CC} SUPPLY VOLTAGE
(DRIVING ONE I/O V_L)**

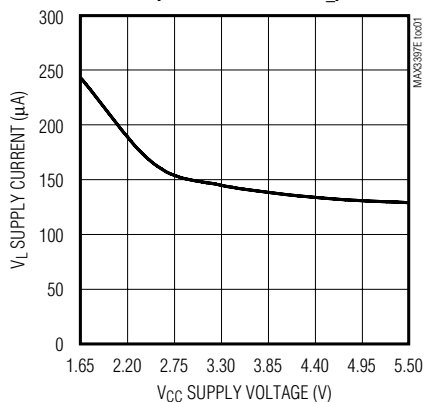

**V_L SUPPLY CURRENT vs. V_{CC} SUPPLY VOLTAGE
(DRIVING ONE I/O V_{CC})**

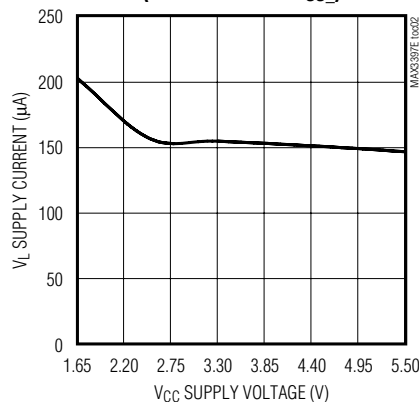

**V_{CC} SUPPLY CURRENT vs. V_L SUPPLY VOLTAGE
(DRIVING ONE I/O V_L)**

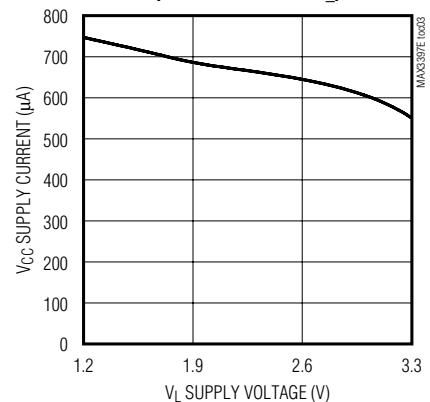

Dual Bidirectional Low-Level Translator in μ DFN

MAX3397E

Typical Operating Characteristics (continued)

($V_{CC} = +3.3V$, $V_L = +1.8V$, $R_{LOAD} = 1M\Omega$, $C_{LOAD} = 15pF$, $T_A = +25^\circ C$, data rate = 8Mbps, unless otherwise noted.)

**V_{CC} SUPPLY CURRENT vs. V_L SUPPLY VOLTAGE
(DRIVING ONE I/O V_{CC})**

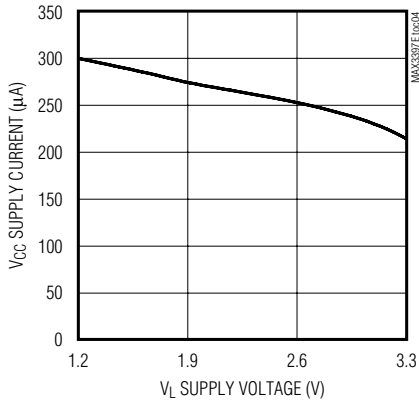

**V_L SUPPLY CURRENT vs. TEMPERATURE
(DRIVING ONE I/O V_L)**

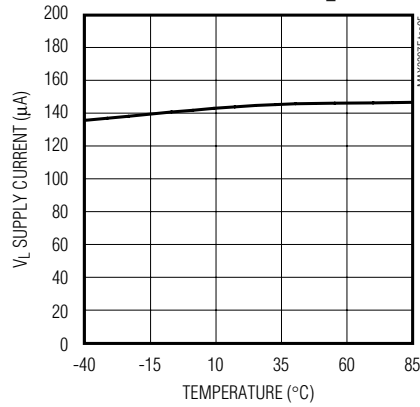

**V_L SUPPLY CURRENT vs. TEMPERATURE
(DRIVING ONE I/O V_{CC})**

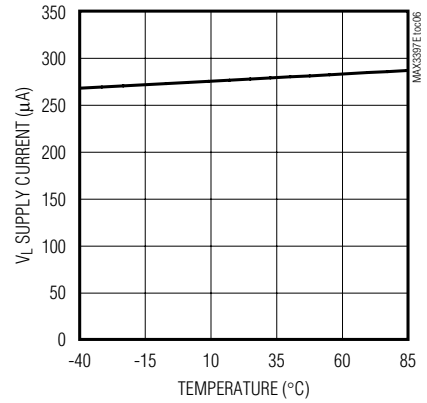

**V_L SUPPLY CURRENT vs. CAPACITIVE LOAD
(DRIVING ONE I/O V_L)**

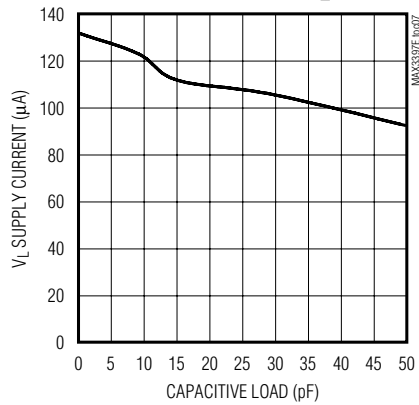

**V_{CC} SUPPLY CURRENT vs. CAPACITIVE LOAD
(DRIVING ONE I/O V_L)**

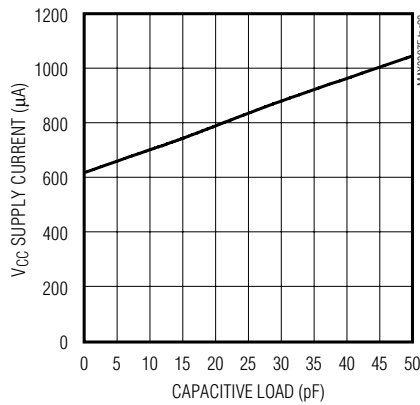

**RISE/FALL TIME vs. CAPACITIVE LOAD
(DRIVING ONE I/O V_L)**

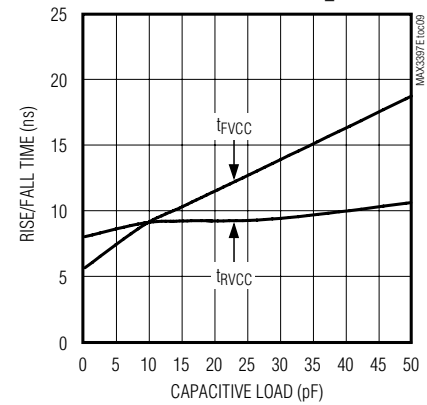

**PROPAGATION DELAY vs. CAPACITIVE LOAD
(DRIVING ONE I/O V_L)**

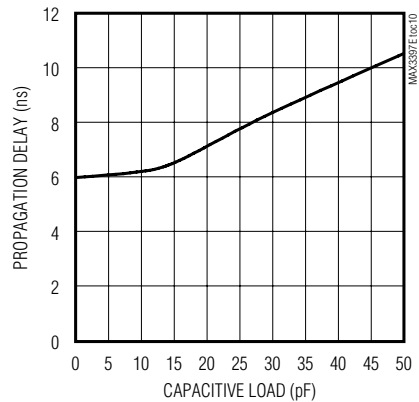

**RISE/FALL TIME vs. CAPACITIVE LOAD
(DRIVING ONE I/O V_{CC})**

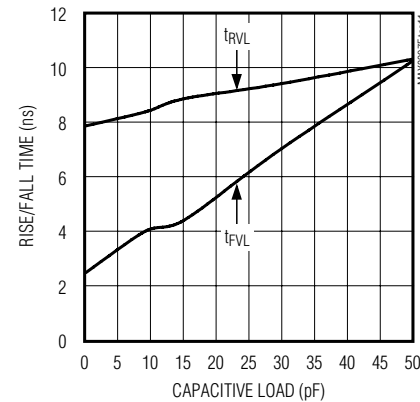

**PROPAGATION DELAY vs. CAPACITIVE LOAD
(DRIVING ONE I/O V_{CC})**

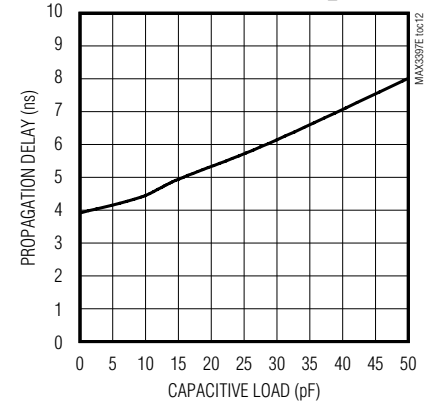

Dual Bidirectional Low-Level Translator in μ DFN

Typical Operating Characteristics (continued)

($V_{CC} = +3.3V$, $V_L = +1.8V$, $R_{LOAD} = 1M\Omega$, $C_{LOAD} = 15pF$, $T_A = +25^\circ C$, data rate = 8Mbps, unless otherwise noted.)

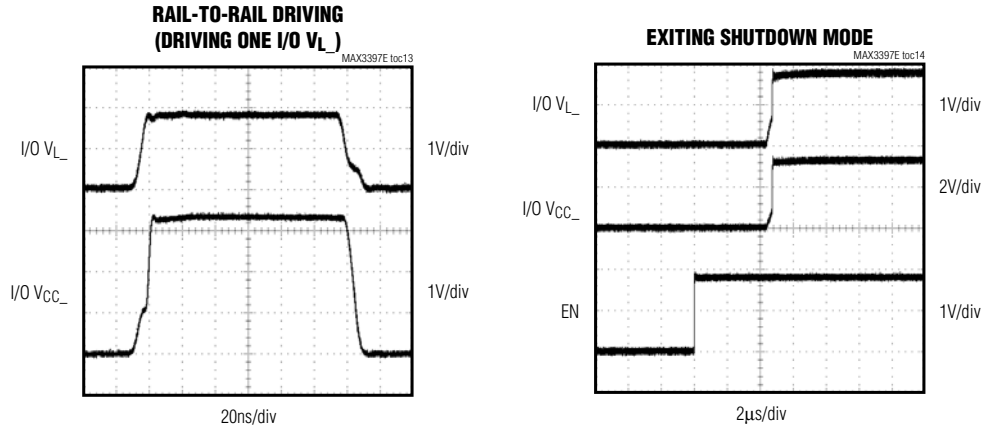

Pin Description

PIN	NAME	FUNCTION
1	I/O V _{CC2}	Input/Output 2. Referenced to V _{CC} .
2	GND	Ground
3	V _L	Logic-Input Voltage. The supply voltage range is $+1.2V \leq V_L \leq +5.5V$. Bypass this supply with a 0.1μF capacitor located as close as possible to the input.
4	I/O V _{L2}	Input/Output 2. Referenced to V _L .
5	I/O V _{L1}	Input/Output 1. Referenced to V _L .
6	EN	Enable Input. Drive EN high to enable the device. Drive EN low to put the device in shutdown mode.
7	V _{CC}	V _{CC} Input Voltage. The supply voltage range is $+1.65V \leq V_{CC} \leq +5.5V$. Bypass this supply with a 0.1μF capacitor located as close as possible to the input. A 1μF ceramic capacitor is recommended for full ESD protection.
8	I/O V _{CC1}	Input/Output 1. Referenced to V _{CC} .

Detailed Description

The MAX3397E bidirectional, ESD-protected level translator provides the level shifting necessary to allow data transfer in a multivoltage system. Externally applied voltages, V_{CC} and V_L, set the logic levels on either side of the device. A logic-low signal present on the V_L side of the device appears as a logic-low signal on the V_{CC} side of the device, and vice versa. The device uses a transmission-gate-based design (see the *Functional Diagram*) to allow data translation in either direction (V_L ↔ V_{CC}) on any single data line. The MAX3397E accepts V_L from +1.2V to +5.5V and V_{CC}

from +1.65V to +5.5V, making the device ideal for data transfer between low-voltage ASICs/PLDs and higher voltage systems.

The MAX3397E features a shutdown mode that reduces the supply current to less than 1μA, thermal short-circuit protection, and ±15kV ESD protection on the V_{CC} side for greater protection in applications that route signals externally. The device operates at a guaranteed data rate of 8Mbps over the entire specified operating voltage range. Within specific voltage domains, higher data rates are possible. See the *Timing Characteristics* table.

Dual Bidirectional Low-Level Translator in μ DFN

MAX3397E

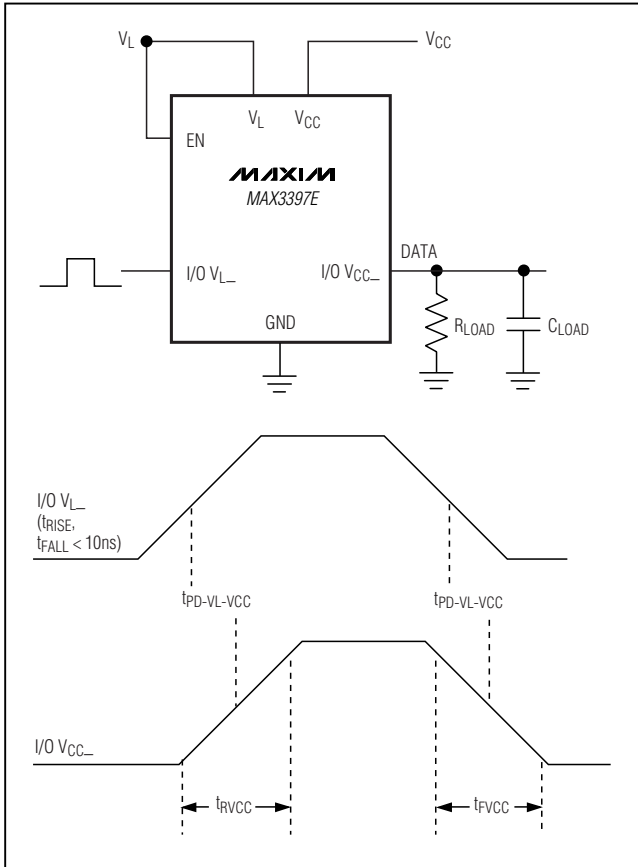

Figure 1a. Rail-to-Rail Driving I/O V_L

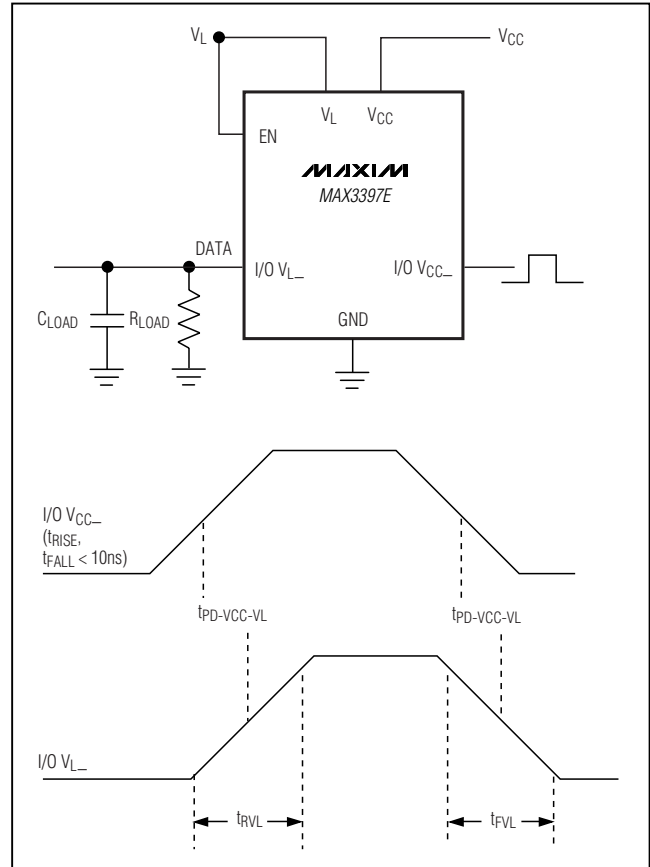

Figure 1b. Rail-to-Rail Driving I/O V_{CC}

Level Translation

For proper operation, ensure that $+1.65V \leq V_{CC} \leq +5.5V$ and $+1.2V \leq V_L \leq +5.5V$. During power-up sequencing, $V_L \geq (V_{CC} + 0.3V)$ does not damage the device. The speed-up circuitry limits the maximum data rate for the MAX3397E to 16Mbps. The maximum data rate also depends heavily on the load capacitance (see the *Typical Operating Characteristics*), output impedance of the driver, and the operational voltage range (see the *Timing Characteristics* table).

Rise-Time Accelerators

The MAX3397E has an internal rise-time accelerator, allowing operation up to 16Mbps. The rise-time accelerators are present on both sides of the device and act to speed up the rise time of the input and output of the device, regardless of the direction of the data. The triggering mechanism for these accelerators is both level and edge sensitive. To prevent false triggering of the rise-time accelerators, signal fall times of less than

20ns/V are recommended for both the inputs and outputs of the device. Under less noisy conditions, longer signal fall times are acceptable. **Note:** To guarantee operation of the rise time accelerators the maximum parasitic capacitance should be less than 200pF on the I/O lines.

Shutdown Mode

Drive EN low to place the MAX3397E in shutdown mode. Connect EN to V_L or V_{CC} (logic-high) for normal operation. Activating the shutdown mode disconnects the internal $10k\Omega$ pullup resistors on the I/O V_{CC} and I/O V_L lines. This forces the I/O lines to a high-impedance state, and decreases the supply current to less than $1\mu A$. The high-impedance I/O lines in shutdown mode allow for use in a multidrop network. The MAX3397E effectively has a diode from each I/O to the corresponding supply rail and GND. Therefore, when in shutdown mode, do not allow the voltage at I/O V_L to exceed $(V_L + 0.3V)$, or the voltage at I/O V_{CC} to exceed $(V_{CC} + 0.3V)$.

Dual Bidirectional Low-Level Translator in μ DFN

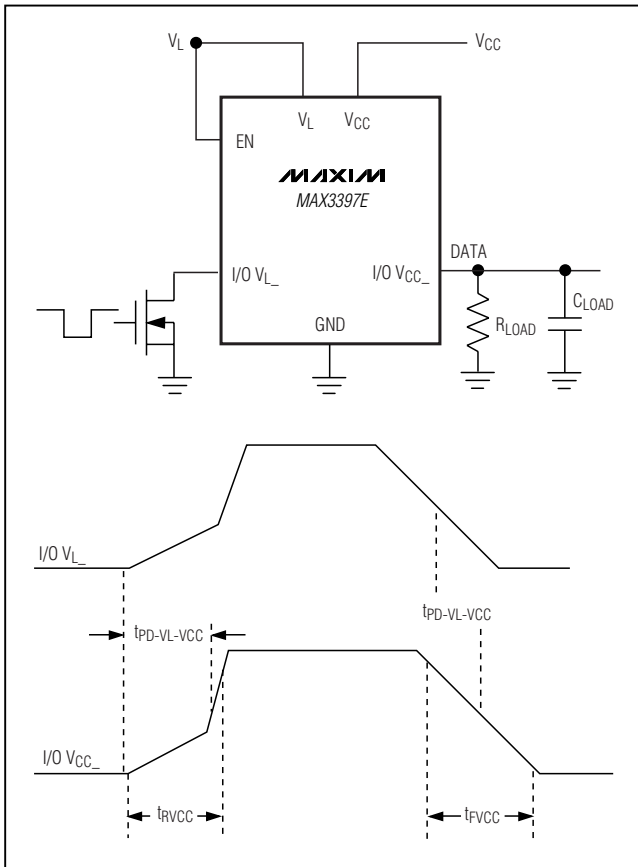

Figure 1c. Open-Drain Driving I/O V_L

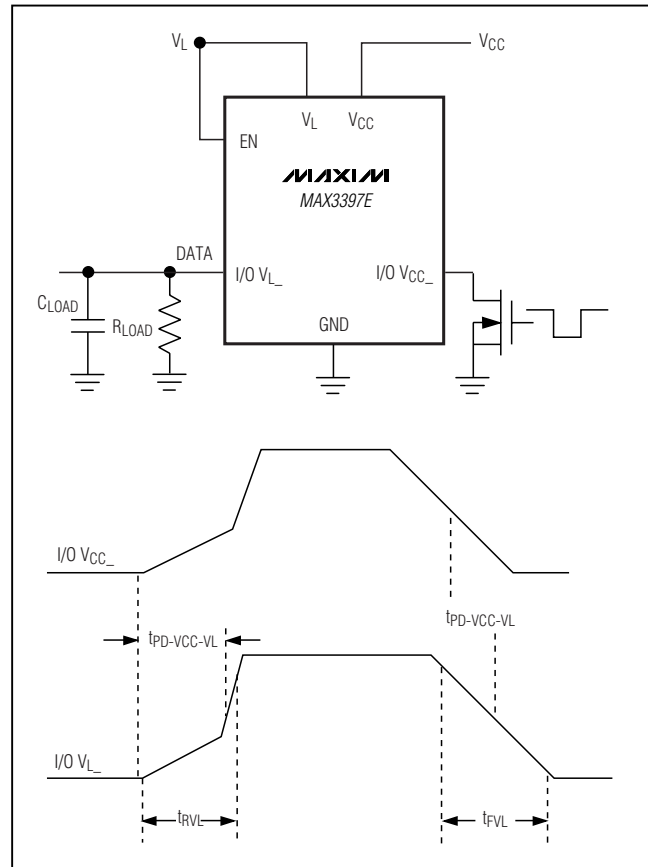

Figure 1d. Open-Drain Driving I/O V_{CC}

Operation with One Supply Disconnected

Certain applications require sections of circuitry to be disconnected to save power. When V_L is connected and V_{CC} is disconnected or connected to ground, the device enters shutdown mode. In this mode, I/O V_L can still be driven without damage to the device; however, data does not translate from I/O V_L to I/O V_{CC} . If V_{CC} falls more than 0.8V (typ) below V_L , the device disconnects the pullup resistors at I/O V_L and I/O V_{CC} . To achieve the lowest possible supply current from V_L when V_{CC} is disconnected, it is recommended that the voltage at the V_{CC} supply input be approximately equal to GND. **Note:** When V_{CC} is disconnected or connected to ground, I/O V_{CC} must not be driven more than $V_{CC} + 0.3V$.

When V_{CC} is connected and V_L is less than 0.7V (typ), the device enters shutdown mode. In this mode, I/O V_{CC} can still be driven without damage to the device; however, data does not translate from I/O V_{CC} to I/O V_L . **Note:** When V_L is disconnected or connected to ground, I/O V_L must not be driven more than $V_L + 0.3V$.

Thermal Short-Circuit Protection

Thermal-overload detection protects the MAX3397E from short-circuit fault conditions. In the event of a short-circuit fault, when the junction temperature (T_J) reaches $+150^\circ\text{C}$, a thermal sensor signals the shutdown mode logic to force the device into shutdown mode. When the T_J has cooled to $+140^\circ\text{C}$, normal operation resumes.

$\pm 15\text{kV}$ ESD Protection

As with all Maxim devices, ESD-protection structures are incorporated on all pins to protect against electrostatic discharges encountered during handling and assembly. The I/O V_{CC} lines have extra protection against static electricity. Maxim's engineers have developed state-of-the-art structures to protect these pins against ESD of $\pm 15\text{kV}$ without damage. The ESD structures withstand high ESD in all states: normal operation, shutdown mode, and powered down. After an ESD event, Maxim's E versions keep working without

Dual Bidirectional Low-Level Translator in μ DFN

MAX3397E

Functional Diagram

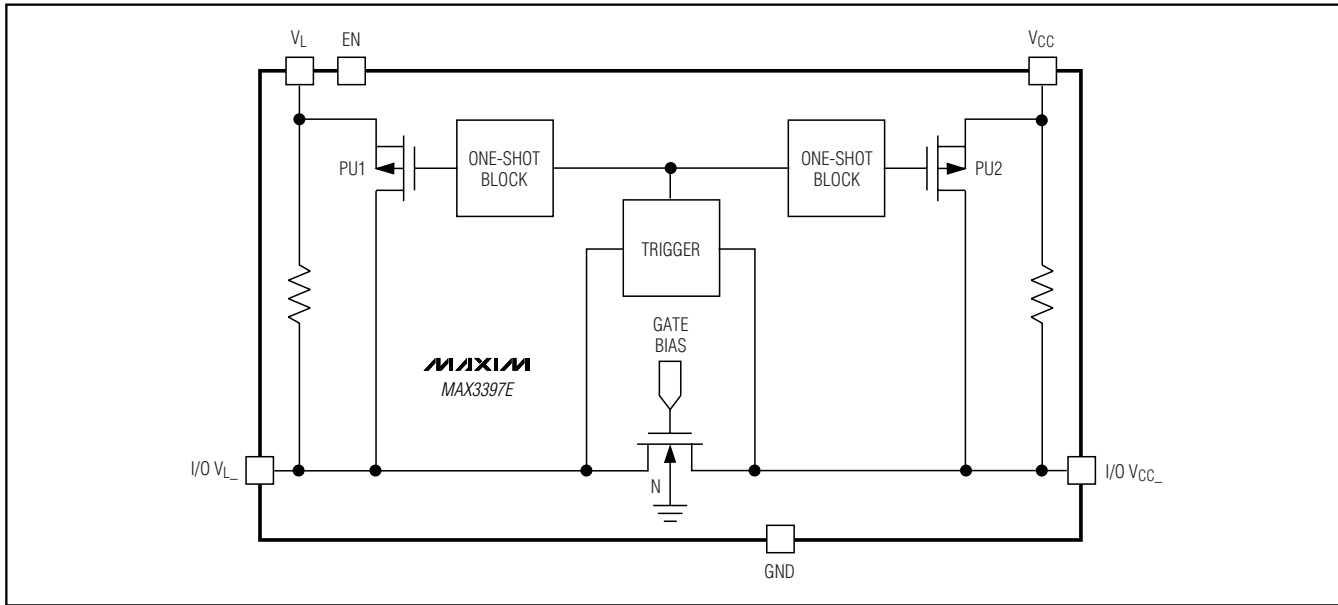

latchup, whereas competing products can latch and must be powered down to remove latchup. ESD protection can be tested in various ways. The I/O V_{CC} lines of the MAX3397E are characterized for protection to the following limits:

- 1) $\pm 15\text{kV}$ using the Human Body Model
- 2) $\pm 8\text{kV}$ using the Contact Discharge method specified by IEC 61000-4-2
- 3) $\pm 15\text{kV}$ using the Air-Gap Discharge method specified by IEC 61000-4-2

ESD Test Conditions

ESD performance depends on a variety of conditions. Contact Maxim for a reliability report that documents test setup, test methodology, and test results.

Human Body Model

Figure 2a shows the Human Body Model, and Figure 2b shows the current waveform it generates when discharged into a low-impedance state. This model consists of a 100pF capacitor charged to the ESD voltage of interest that is then discharged into the test device through a $1.5\text{k}\Omega$ resistor.

IEC 61000-4-2

The IEC 61000-4-2 standard covers ESD testing and performance of finished equipment; it does not specifically refer to integrated circuits. The MAX3397E helps

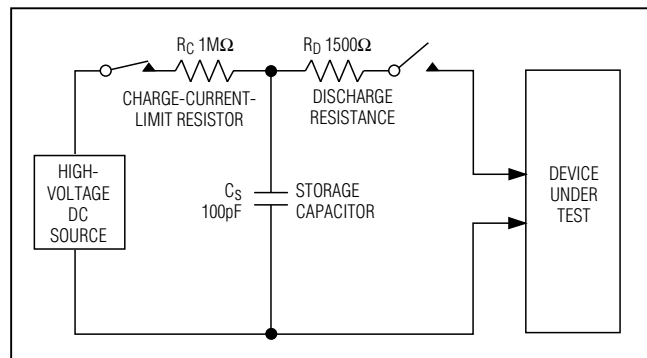

Figure 2a. Human Body ESD Test Model

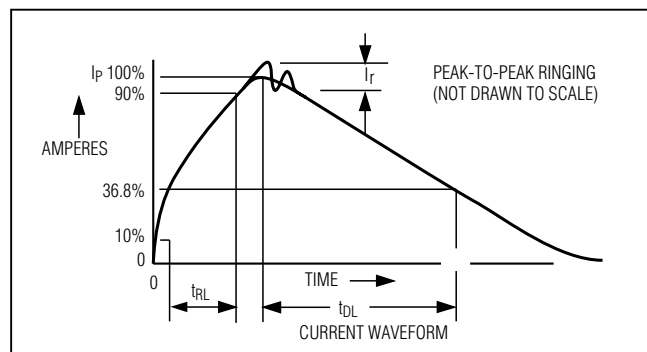

Figure 2b. Human Body Current Waveform

Dual Bidirectional Low-Level Translator in μ DFN

to design equipment that meets Level 4 of IEC 61000-4-2 without the need for additional ESD-protection components.

The major difference between tests done using the Human Body Model and IEC 61000-4-2 is higher peak current in IEC 61000-4-2 because series resistance is lower in the IEC 61000-4-2 model. Hence, the ESD withstand voltage measured to IEC 61000-4-2 is generally lower than that measured using the Human Body Model. Figure 3a shows the IEC 61000-4-2 model, and Figure 3b shows the current waveform for the $\pm 8\text{kV}$, IEC 61000-4-2, Level 4, ESD contact-discharge test.

The Air-Gap test involves approaching the device with a charged probe. The contact-discharge method connects the probe to the device before the probe is energized.

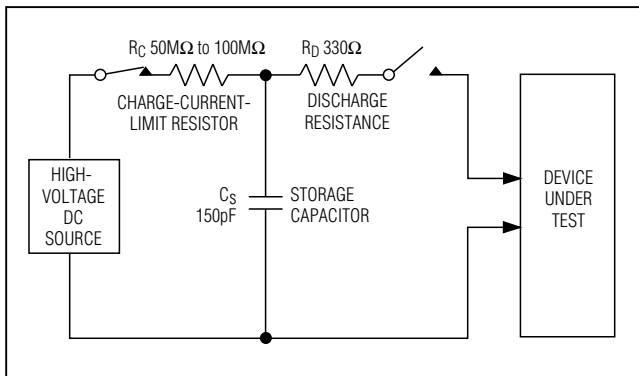

Figure 3a. IEC 61000-4-2 ESD Test Model

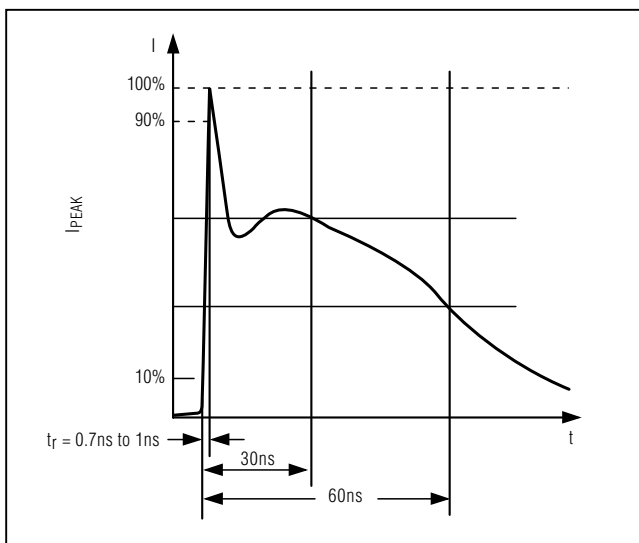

Figure 3b. IEC 61000-4-2 ESD Generator Current Waveform

Machine Model

The Machine Model for ESD tests all pins using a 200pF storage capacitor and zero discharge resistance. Its objective is to emulate the stress caused by contact that occurs with handling and assembly during manufacturing. Of course, all pins require this protection during manufacturing, not just inputs and outputs. Therefore, after PCB assembly, the Machine Model is less relevant to I/O ports.

Applications Information

Power-Supply Decoupling

To reduce ripple and the chance of transmitting incorrect data, bypass V_L and V_{CC} to ground with a 0.1 μF capacitor (see the *Typical Application Circuit*). To ensure full $\pm 15\text{kV}$ ESD protection, bypass V_{CC} to ground with a 1 μF capacitor. Place all capacitors as close as possible to the power-supply inputs.

I²C Level Translation

The MAX3397E level-shifts the data present on the I/O lines between +1.2V and +5.5V, making them ideal for level translation between a low-voltage ASIC and an I²C device. A typical application involves interfacing a low-voltage microprocessor to a 3V or 5V D/A converter, such as the MAX517.

Push-Pull vs. Open-Drain Driving

The MAX3397E can be driven in a push-pull configuration and include internal 10k Ω resistors that pull up I/O V_{L-} and I/O V_{CC-} to their respective power supplies, allowing operation of the I/O lines with open-drain devices. See the *Timing Characteristics* table for maximum data rates when using open-drain drivers.

Chip Information

PROCESS: BiCMOS

Dual Bidirectional Low-Level Translator in μ DFN

Typical Application Circuit

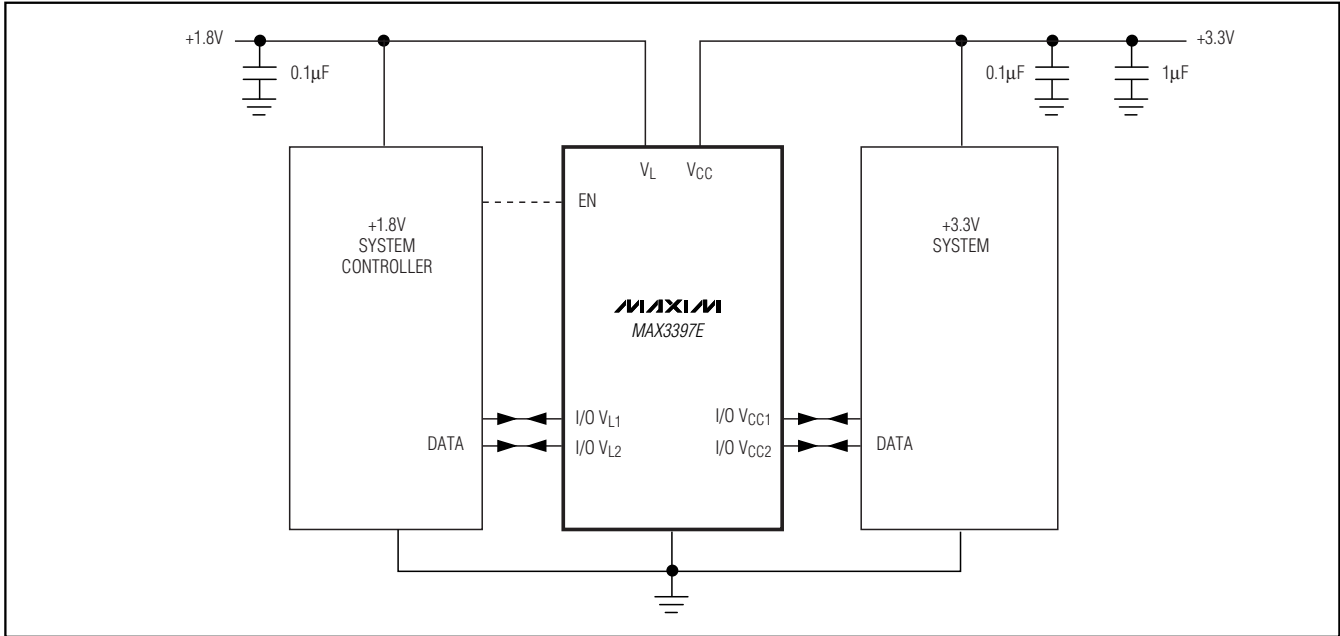

MAX3397E

Dual Bidirectional Low-Level Translator in μ DFN

Package Information

(The package drawing(s) in this data sheet may not reflect the most current specifications. For the latest package outline information, go to www.maxim-ic.com/packages.)

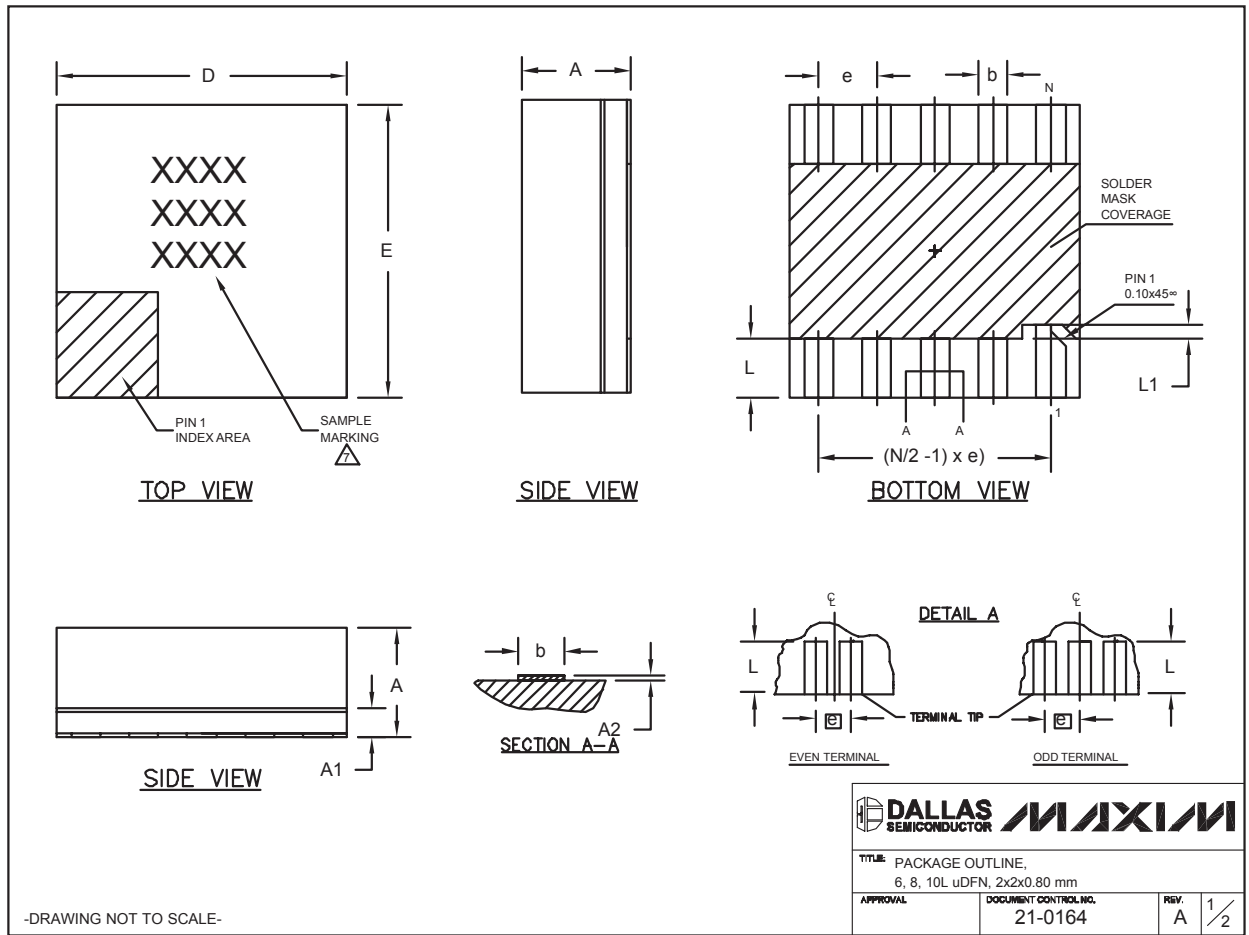

6, 8, 10L μ DFN:EPS

Dual Bidirectional Low-Level Translator in μ DFN

MAX3397E

Package Information (continued)

(The package drawing(s) in this data sheet may not reflect the most current specifications. For the latest package outline information, go to www.maxim-ic.com/packages.)

COMMON DIMENSIONS			
SYMBOL	MIN.	NOM.	MAX.
A	0.70	0.75	0.80
A1	0.15	0.20	0.25
A2	0.020	0.025	0.035
D	1.95	2.00	2.05
E	1.95	2.00	2.05
L	0.30	0.40	0.50
L1	0.10 REF.		

PACKAGE VARIATIONS				
PKG. CODE	N	e	b	(N/2 -1) x e
L622-1	6	0.65 BSC	0.30±0.05	1.30 REF.
L822-1	8	0.50 BSC	0.25±0.05	1.50 REF.
L1022-1	10	0.40 BSC	0.20±0.03	1.60 REF.

NOTES:

1. ALL DIMENSIONS ARE IN mm. ANGLES IN DEGREES.
 2. COPLANARITY SHALL NOT EXCEED 0.08mm.
 3. WARPAGE SHALL NOT EXCEED 0.10mm.
 4. PACKAGE LENGTH/PACKAGE WIDTH ARE CONSIDERED AS SPECIAL CHARACTERISTIC(S).
 5. "N" IS THE TOTAL NUMBER OF LEADS.
 6. NUMBER OF LEADS SHOWN ARE FOR REFERENCE ONLY.
-  MARKING IS FOR PACKAGE ORIENTATION REFERENCE ONLY.

-DRAWING NOT TO SCALE-

 	
TITLE: PACKAGE OUTLINE, 6, 8, 10L μ DFN, 2x2x0.80 mm	
APPROVAL	DOCUMENT CONTROL NO. 21-0164
REV: A	REV: 2/2

Maxim cannot assume responsibility for use of any circuitry other than circuitry entirely embodied in a Maxim product. No circuit patent licenses are implied. Maxim reserves the right to change the circuitry and specifications without notice at any time.

Maxim Integrated Products, 120 San Gabriel Drive, Sunnyvale, CA 94086 408-737-7600 _____ **13**

X-ON Electronics

Largest Supplier of Electrical and Electronic Components

Click to view similar products for [Translation - Voltage Levels](#) category:

Click to view products by [Maxim](#) manufacturer:

Other Similar products are found below :

[NLSX4373DMR2G](#) [NLSX5012MUTAG](#) [NLSX0102FCT2G](#) [NLSX4302EBMUTCG](#) [PCA9306FMUTAG](#) [MC100EPT622MNG](#)
[NLSX5011MUTCG](#) [NLV9306USG](#) [NLVSVX4014MUTAG](#) [NLSV4T3144MUTAG](#) [NLVSVX4373MUTAG](#) [MAX3371ELT+T](#)
[NLSX3013BFCT1G](#) [NLV7WBD3125USG](#) [NLSX3012DMR2G](#) [74AVCH1T45FZ4-7](#) [NLVSV1T244MUTBG](#) [74AVC1T45GS-Q100H](#)
[CLVC16T245MDGGREP](#) [MC10H124FNG](#) [CAVCB164245MDGGREP](#) [CD40109BPWR](#) [MC10H350FNG](#) [MC10H125FNG](#)
[MC100EPT21MNR4G](#) [MC100EP91DWG](#) [NLSV2T244MUTAG](#) [NLSX3013FCT1G](#) [NLSX5011AMX1TCG](#) [PCA9306USG](#)
[SN74GTL1655DGGR](#) [SN74AVCA406LZQSR](#) [NLSX4014DTR2G](#) [NLSX3018DTR2G](#) [LTC1045CN#PBF](#) [SY100EL92ZG](#)
[74AXP1T34GMH](#) [74AXP1T34GNH](#) [LSF0204DPWR](#) [PI4ULS3V204LE](#) [ADG3245BRUZ-REEL7](#) [ADG3123BRUZ](#) [ADG3245BRUZ](#)
[ADG3246BCPZ](#) [ADG3308BCPZ-REEL](#) [ADG3233BRJZ-REEL7](#) [ADG3233BRMZ](#) [ADG3242BRJZ-REEL7](#) [ADG3243BRJZ-REEL7](#)
[ADG3245BCPZ](#)