

## MAX38642A $\mu$ DFN Evaluation Kit

Evaluates: MAX38642 A in  $\mu$ DFN

### General Description

The MAX38642A evaluation kit (EV kit) evaluates the MAX38642A, an ultra-low quiescent current step-down DC-DC converter in the  $\mu$ DFN package. The EV kit operates over an input range of 1.8V to 5.5V, and provides resistor-configurable output voltages from 1.0V to 3.3V. The EV kit delivers up to 350mA of current depending on the input voltage to the output voltage ratio.

The EV kit comes with the MAX38642AELT+ installed.

### Features

- Evaluates the MAX38642A in a 6-pin  $\mu$ DFN
- 1.8V to 5.5V Input Range
- 1.0V to 3.3V Configurable Output Voltage
- Up to 350mA Output Current
- Proven 2-Layer 1oz Copper PCB Layout
- Demonstrates Compact Solution Size
- Fully Assemble and Tested

**Ordering Information** appears at end of data sheet.

### MAX38642A EV Kit Files

FILE	DESCRIPTION
MAX38642A $\mu$ DFN EV BOM	EV Kit Bill of Material
MAX38642A $\mu$ DFN EV PCB Layout	EV Kit Layout
MAX38642A $\mu$ DFN EV Schematic	EV Kit Schematic

### Quick Start

#### Required Equipment

- MAX38642A  $\mu$ DFN EV kit
- 5.5V, 3A DC power supply
- Electronic load capable of 350mA
- Digital voltmeter (DVM)

#### Procedure

The EV kit is fully assembled and tested. Follow the steps below to verify board operation.

**Caution: Do not turn on power supply until all connections are completed.**

- 1) Verify that jumpers JU1 and JU2 are in their default positions, as shown in [Table 1](#) and [Table 2](#).
- 2) Connect the 5.5V power supply between the IN and nearest GND terminal posts.
- 3) Connect the 350mA electronic load between the OUT and nearest GND terminal posts.
- 4) Connect the DVM between the OUT and nearest GND terminal posts.
- 5) Turn on the power supply.
- 6) Enable the electronic load.
- 7) Verify that the voltage at the OUT terminal post is 1.8V, within the device and the Output Voltage Selecting Resistor (RSEL)'s accuracy specifications.

### Detailed Description of Hardware

The MAX38642A EV kit evaluates the MAX38642A, an ultra-low quiescent current step-down DC-DC converter in the  $\mu$ DFN package. The EV kit operates over an input range of 1.8V to 5.5V, and provides resistor-configurable output voltages from 1.0V to 3.3V. The EV kit delivers up to 350mA of current depending on the input voltage to the output voltage ratio.

The EV kit comes with the MAX38642AELT+ installed.

#### EN

The MAX38642A  $\mu$ DFN EV kit provides a jumper JU1 to enable or disable the MAX38642A. Refer to [Table 1](#) for jumper JU1 settings.

**Table 1. EN (JU1)**

SHUNT POSITION	DESCRIPTION
1-2*	EV Kit Enabled
1-3	EV Kit Controlled by External (TTL) Source Connected to EXT_EN
1-4	EV Kit Disabled

\*Default position.

### Component Suppliers

SUPPLIER	WEBSITE
Murata	www.murata.com
Samsung Electronics	www.samsung.com
Würth Electronics	www.we-online.com

**Note:** Indicate that you are using the MAX38642A when contacting these component suppliers.

### Ordering Information

PART	TYPE
MAX38642AEVK# $\mu$ DFN	EV Kit

#Denotes RoHS

### Output Voltage Selection

The MAX38642A  $\mu$ DFN EV kit provides a jumper JU2 to select the MAX38642A output voltage. Refer to [Table 2](#) for jumper JU2 settings.

### Spare Inductor

The MAX38642A  $\mu$ DFN EV kit provides a spare inductor on the PCB's bottom side. This spare inductor can be used to reconfigure the EV kit for a smaller solution size.

**Table 2. OUT (JU2)**

SHUNT POSITION	DESCRIPTION
1-2	OUT = 1.0V
1-3	OUT = 1.5V
1-4*	OUT = 1.8V
1-5	OUT = 3.3V
Not Installed	Output Voltage can be configured to between 0.7V and 3.3V by resistor R1. Refer to the IC data sheet.

\*Default position.

MAX38642A  $\mu$ DFN EV Kit Bill of Materials

ITEM	REF_DES	DN/DNP	QTY	MFG PART #	MANUFACTURER	VALUE	DESCRIPTION	COMMENTS
1	C1-C3	-	3	CL10A226KQ8NRN	SAMSUNG	22UF	CAP; SMT (0603); 22UF; 10%; 6.3V; X5R; CERAMIC CHIP	
2	C5	-	1	25SVPF100M	PANASONIC	100UF	CAP; SMT (CASE_E7); 100UF; 20%; 25V; ALUMINUM-ORGANIC	
3	J1-J4	-	4	1514-2	KEYSTONE	1514-2	TERMINAL; TURRET; PIN DIA=0.090IN; TOTAL LENGTH=0.105IN; BOARD HOLE=0.098IN; BRASS; TIN PLATING;	
4	JU1	-	1	PEC04SAAN	SULLINS ELECTRONICS CORP.	PEC04SAAN	CONNECTOR; MALE; THROUGH HOLE; BREAKAWAY; STRAIGHT; 4PINS	
5	JU2	-	1	PBC05SAAN	SULLINS ELECTRONICS CORP.	PBC05SAAN	CONNECTOR; MALE; THROUGH HOLE; BREAKAWAY; STRAIGHT; 5PINS; -65 DEGC TO +125 DEGC	
6	L1	-	1	74437324022□	WURTH ELECTRONICS INC	2.2UH	INDUCTOR; SMT; SHIELDED; 2.2UH; 20%; 3.25A	
7	L1A	-	1	DFE201612E-2R2M	MURATA	2.2UH	INDUCTOR; SMT (0806); WIREWOUND CHIP; 2.2UH; TOL=+/-20%; 1.8A	
8	R2	-	1	CRCW0603191KFK	VISHAY DALE	191K	RESISTOR; 0603; 191K OHM; 1%; 100PPM; 0.10W; METAL FILM	
9	R3	-	1	ERJ-3EKF6343	PANASONIC	634K	RES; SMT (0603); 634K; 1%; +/-100PPM/DEGC; 0.1W	
10	R4	-	1	CRCW060320K0FK	VISHAY DALE	20K	RESISTOR; 0603; 20K OHM; 1%; 100PPM; 0.1W; THICK FILM	
11	R5	-	1	ERJ-3EKF5622	PANASONIC	56.2K	RESISTOR; 0603; 56.2K OHM; 1%; 100PPM; 0.1W; THICK FILM	
12	R6	-	1	RC1608J000CS; CR0603-J/-000ELF; RC0603JR-070RL	SAMSUNG ELECTRONICS; BOURNS;YAGEO PH	0	RESISTOR; 0603; 0 OHM; 5%; JUMPER; 0.10W; THICK FILM	
13	SU1, SU2	-	2	S1100-B;SX1100-B; STC02SYAN	KYCON;KYCON;SULLINS ELECTRONICS CORP.	SX1100-B	TEST POINT; JUMPER; STR; TOTAL LENGTH=0.24IN; BLACK; INSULATION=PBT;PHOSPHOR BRONZE CONTACT=GOLD PLATED	
14	TP5	-	1	5002	KEYSTONE	N/A	TEST POINT; PIN DIA=0.1IN; TOTAL LENGTH=0.3IN; BOARD HOLE=0.04IN; WHITE; PHOSPHOR BRONZE WIRE SILVER;	
15	TP6, TP7	-	2	5001	KEYSTONE	N/A	TEST POINT; PIN DIA=0.1IN; TOTAL LENGTH=0.3IN; BOARD HOLE=0.04IN; BLACK; PHOSPHOR BRONZE WIRE SILVER PLATE FINISH;	
16	U1	-	1	MAX38642AELT+	MAXIM	MAX38642AELT+	EVKIT PART - IC; TINY 300NANO-AMP NANOPOWER BUCK CONVERTER; PACKAGE OUTLINE: 21-0164; PACKAGE CODE: L622+1C; PACKAGE LAND PATTERN: 90-0004; DFN6	
17	PCB	-	1	MAX38642AUDFN	MAXIM	PCB	PCB:MAX38642AUDFN	-
18	MH1-MH4	DNP	0	9032	KEYSTONE	9032	MACHINE FABRICATED; ROUND-THRU HOLE SPACER; NO THREAD; M3.5; 5/8IN; NYLON	
19	R1	DNP	0	CRCW06030000Z0	VISHAY DALE	0	RESISTOR; 0603; 0 OHM; 0%; JUMPER; 0.1W; THICK FILM	
20	C4	DNP	0	N/A	N/A	OPEN	PACKAGE OUTLINE 0603 NON-POLAR CAPACITOR	
TOTAL			24					

MAX38642A  $\mu$ DFN EV Kit Schematic

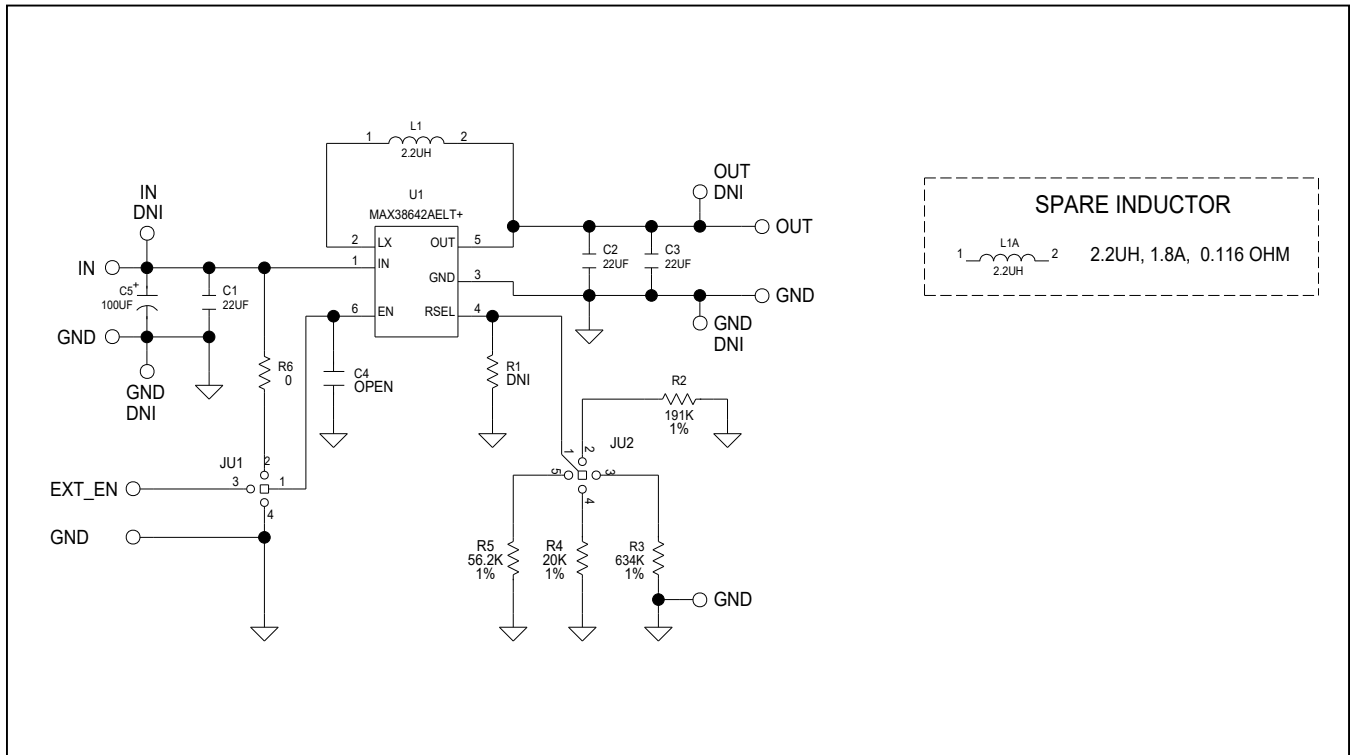

MAX38642A  $\mu$ DFN EV Kit PCB Layout Diagrams

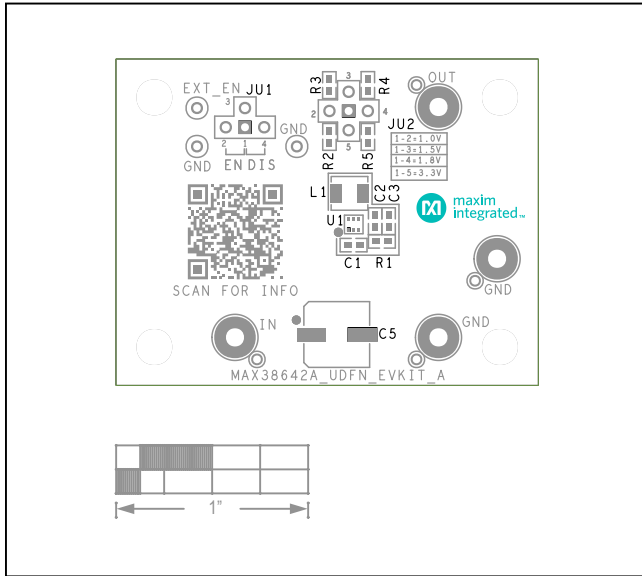

MAX38642A  $\mu$ DFN EV Kit—Top Silkscreen

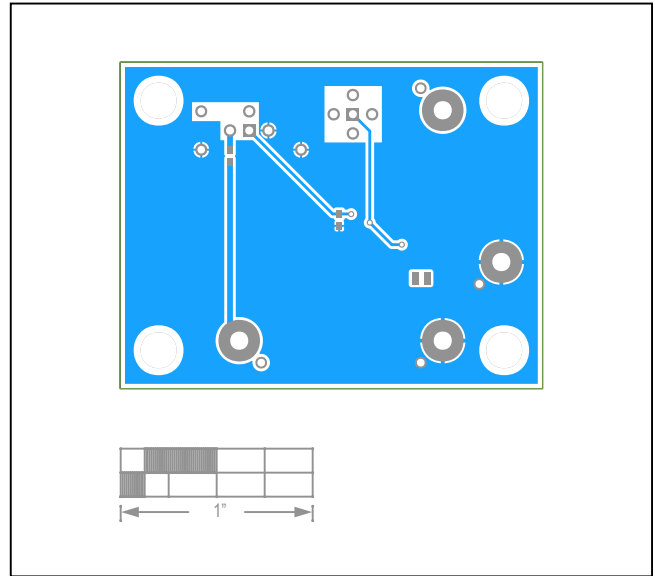

MAX38642A  $\mu$ DFN EV Kit—Bottom

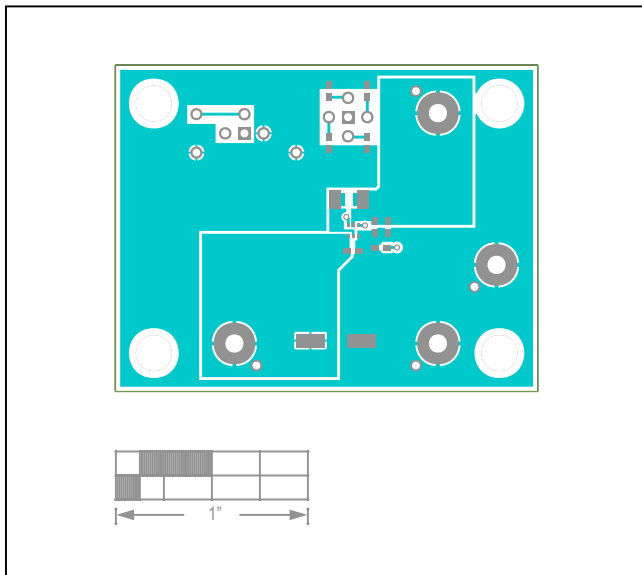

MAX38642A  $\mu$ DFN EV Kit—Top

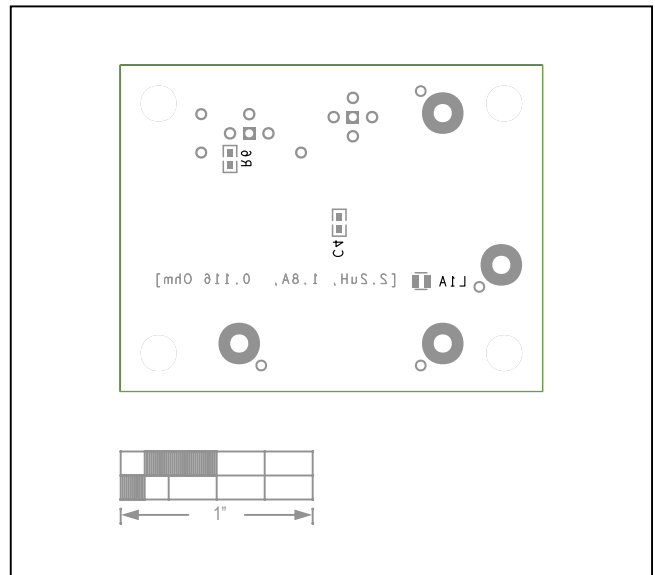

MAX38642A  $\mu$ DFN EV Kit—Bottom Silkscreen

## Revision History

REVISION NUMBER	REVISION DATE	DESCRIPTION	PAGES CHANGED
0	4/19	Initial release	—
1	7/19	Updated title of data sheet	1–6

For pricing, delivery, and ordering information, please visit Maxim Integrated's online storefront at <https://www.maximintegrated.com/en/storefront/storefront.html>.

*Maxim Integrated cannot assume responsibility for use of any circuitry other than circuitry entirely embodied in a Maxim Integrated product. No circuit patent licenses are implied. Maxim Integrated reserves the right to change the circuitry and specifications without notice at any time.*

## X-ON Electronics

Largest Supplier of Electrical and Electronic Components

*Click to view similar products for [Power Management IC Development Tools](#) category:*

*Click to view products by [Maxim](#) manufacturer:*

Other Similar products are found below :

[EVB-EP5348UI](#) [MIC23451-AAAYFL EV](#) [MIC5281YMME EV](#) [124352-HMC860LP3E](#) [DA9063-EVAL](#) [ADP122-3.3-EVALZ](#) [ADP130-0.8-EVALZ](#) [ADP130-1.8-EVALZ](#) [ADP1740-1.5-EVALZ](#) [ADP1870-0.3-EVALZ](#) [ADP1874-0.3-EVALZ](#) [ADP199CB-EVALZ](#) [ADP2102-1.25-EVALZ](#) [ADP2102-1.875EVALZ](#) [ADP2102-1.8-EVALZ](#) [ADP2102-2-EVALZ](#) [ADP2102-3-EVALZ](#) [ADP2102-4-EVALZ](#) [AS3606-DB](#) [BQ25010EVM](#) [BQ3055EVM](#) [ISLUSBI2CKIT1Z](#) [LP38512TS-1.8EV](#) [EVAL-ADM1186-1MBZ](#) [EVAL-ADM1186-2MBZ](#) [ADP122UJZ-REDYKIT](#) [ADP166Z-REDYKIT](#) [ADP170-1.8-EVALZ](#) [ADP171-EVALZ](#) [ADP1853-EVALZ](#) [ADP1873-0.3-EVALZ](#) [ADP198CP-EVALZ](#) [ADP2102-1.0-EVALZ](#) [ADP2102-1-EVALZ](#) [ADP2107-1.8-EVALZ](#) [ADP5020CP-EVALZ](#) [CC-ACC-DBMX-51](#) [ATPL230A-EK](#) [MIC23250-S4YMT EV](#) [MIC26603YJL EV](#) [MIC33050-SYHL EV](#) [TPS60100EVM-131](#) [TPS65010EVM-230](#) [TPS71933-28EVM-213](#) [TPS72728YFFEVM-407](#) [TPS79318YEQEVM](#) [UCC28810EVM-002](#) [XILINXPWR-083](#) [LMR22007YMINI-EVM](#) [LP38501ATJ-EV](#)