

## General Description

The MAX40016 evaluation kit (EV Kit) provides a proven design to evaluate the MAX40016 wide dynamic range current sense amplifier. The MAX40016 integrates the sense element, eliminating a bulky and costly external sense/shunt resistor. The device measures four of decades of current (from  $< 300\mu\text{A}$  to 3A) while maintaining a highly accurate output reading. This EV kit demonstrates the MAX40016 in a tiny, space-saving, 15-bump wafer-level package (WLP).

The MAX40016 EV kit PCB comes with the MAX40016ANL+ device installed.

## EV kit Contents

- MAX40016 EV kit board

*Ordering Information appears at end of data sheet.*

## MAX40016 EV Kit Photo



## Features

- Integrated Current Sense Element
- 4-Decade Measurement Range
  - Maintains Accuracy from  $< 300\mu\text{A}$  to 3A
- Withstands Overloads to 4A
- +2.5V to +5.5V Input Common Mode Range
- Low Power Mode Reduces Supply Current to  $< 10\mu\text{A}$
- Tiny 1.98mm x 1.31mm 15-Bump WLP
- $-40^\circ\text{C}$  to  $+125^\circ\text{C}$  Operating Temperature Range
- Evaluates the MAX40016ANL+
- Accommodates Easy-to-Use components
- Proven PCB Layout
- Fully Assembled and Tested

## Quick Start

### Required Equipment

- MAX40016 EV kit
- DC power supply (2.5V to 5.5V)
- Electronic load capable of sinking up to 3A
- Two digital multimeters (DMMs)

**Procedure**

The EV kit is fully assembled and tested. Follow the below to verify board operation.

**Caution:** Do not turn on the power supply or the electronic load until all the connections are made.

**V<sub>ISH</sub> Testing**

- 1) Set the DC power supply to +3.6V and turn it off. Connect the positive terminal of the supply to the V<sub>DD</sub> banana jack test point and the negative terminal of the supply to the nearest GND banana jack test point.
- 2) Set the electronic load to sink 1A. Connect the positive terminal of the electronic load to the VLD banana jack test point and the negative terminal of the supply to the nearest banana jack GND test point.
- 3) Connect DMM1 between V<sub>ISH</sub> and the nearest GND test point.
- 4) Connect DMM2 between V<sub>OUT</sub> and the nearest GND test point.
- 5) Verify all the shunts are in default positions as shown in [Table 1](#).
- 6) Enable the 3.6V supply voltage at V<sub>DD</sub>.
- 7) Turn on the electronic load and verify that the current flowing is equal to the set value of 1A.
- 8) Observe the output voltage from all digital voltmeter displays. Verify that approximately, V<sub>ISH</sub> = 320mV, and V<sub>OUT</sub> = 480mV.
- 9) Turn off the electronic load then turn off the V<sub>DD</sub> supply voltage.

**V<sub>ISM</sub> Testing**

- 1) To test the V<sub>ISM</sub> output, change JU0 from 2-1 to 2-3 position.
- 2) Remove the DMM1 and connect it between V<sub>ISM</sub> and the nearest GND test point.
- 3) Set the electronic load to sink 50mA. Connect the positive terminal of the electronic load to the VLD banana jack test point and the negative terminal of the supply to the nearest banana jack GND test point.
- 4) Enable the 3.6V supply voltage at V<sub>DD</sub>.
- 5) Turn on the electronic load and verify that the current flowing is equal to the set value of 50mA.
- 6) Observe the output voltage from all digital voltmeter displays. Verify that, approximately, V<sub>ISM</sub> = 536mV, and V<sub>OUT</sub> = 804mV.
- 7) Turn off the electronic load, then turn off the V<sub>DD</sub> supply voltage.

**V<sub>ISL</sub> Testing**

- 1) To test the V<sub>ISL</sub> output, change JU0 from 2-3 to 2-1 position, and change JU1 from 2-1 to 2-3 position.
- 2) Remove the DMM1 and connect it between V<sub>ISL</sub> and the nearest GND test point.
- 3) Set the electronic load to sink 1mA.
- 4) Enable the 3.6V supply voltage at V<sub>DD</sub>.
- 5) Turn on the electronic load and verify that the current flowing is equal to the set value of 1mA.
- 6) Observe the output voltage from all digital voltmeter displays. Verify that approximately, V<sub>ISM</sub> = 320mV, and V<sub>OUT</sub> = 480mV.

**Table 1. Jumper Description**

JUMPER	SHUNT POSITION	DESCRIPTION
JU0	2-1*	Connect SEL1 to V <sub>DD</sub>
	2-3	Connect SEL1 to GND
JU1	2-1*	Connect SEL0 to V <sub>DD</sub>
	2-3	Connect SEL0 to GND
JU2	Install*	Connect R1 to ISH
	Not install	Disconnect R1 from ISH
JU3	Install*	Connect R3 to ISL
	Not install	Disconnect R3 from ISL
JU4	Install*	Connect R4 to V <sub>OUT</sub>
	Not install	Disconnect R4 from V <sub>OUT</sub>
JU5	Install*	Connect R2 to ISM
	Not install	Disconnect R2 from ISM

*\*Default position.*

- Turn off the electronic load then turn off the  $V_{DD}$  supply voltage

**Low Power Mode Testing**

- To put the device in low power mode, change JU0 from 2-1 to 2-3 position.
- Enable the 3.6V supply voltage at  $V_{DD}$ .
- Turn on the electronic load and verify that the current flowing is equal to the set value of 1mA.
- Observe the output voltage from all digital voltmeter displays. Verify that  $V_{ISL}$  is about 0mV and  $V_{OUT}$  is 0mV.
- Turn off the electronic load then turn off the  $V_{DD}$  supply voltage.
- Return JU1 and JU2 to the default values stated in [Table 1](#).

**Detailed Description of Hardware**

The MAX40016 EV kit provides a proven design to evaluate the MAX40016 15-bump, WLP, space-saving, wide-range current sense amplifier. The EV kit is capable of sensing from < 300 $\mu$ A to >3A current and is mode-configurable to look at all multiplexed outputs (ISH, ISM, or ISL) and the internal amplifier  $V_{OUT}$  output (see [Table 2](#)).

When programmed in low power mode (SEL0 = SEL1 = GND) the MAX40016 turns off all multiplexed outputs and send the amplifier output to high impedance. The low (10 $\mu$ A typical) supply current is independent of the load current. The MAX40016 EV kit operates from supplies of 2.5V to 5.5V.

**Scaling Resistors**

The typical multiplexed current from the MAX40016’s ISL, or ISM, or ISH pin is specified as 2mA/A. The scaling resistors’ values at ISH, ISM, and ISL should be chosen such as not to exceed the 1V of the internal amplifier input voltage range. Care should be taken to account for all tolerances, not to exceed the 0.01V to 1.0V range of the internal amplifier. The MAX40016 EV Kit has  $R_{ISH} = 160\Omega$ ,  $R_{ISM} = 5.36k\Omega$  and  $R_{ISL} = 160k\Omega$  installed to split the range up equally.

**Power Supplies Bypassing**

The MAX40016 EV kit is fully tested with single supply voltage from +2.5V to +5.5V applying to the VDD and GND banana jack inputs. The VDD supply input is also the measured current input terminal and is bypassed to ground with a 0.1 $\mu$ F in parallel with a 10 $\mu$ F ceramic capacitors. The measured current output, LD terminal, is also bypassed with a 0.1 $\mu$ F in parallel with a 10 $\mu$ F ceramic capacitor. Additional pad holders (C6, C7, C12, and C13) can be used if larger capacitive load needed for experimenting larger load output current transients.

**Table 2. Current Sense Range Selection**

SEL0	SEL1	OPERATING MODE/RANGE
0	0	Low Power Mode is enabled. $V_{OUT}$ is high impedance. In low power mode, the current sensing element still passes current just as an external sense resistor would. There is no capability to turn off the current.
0	1	Middle current sense range (ISM) is enabled. The resistor $R_{ISM}$ connected at this current output terminal defines the full-scale voltage of 1V to the internal amplifier.
1	0	Low current sense range (ISL) is enabled. The resistor $R_{ISL}$ connected at this current output terminal defines the full-scale voltage of 1V to the internal amplifier.
1	1	High current sense range (ISH) is enabled. The resistor $R_{ISH}$ connected at this current output terminal defines the full-scale voltage of 1V to the internal amplifier.

**Ordering Information**

PART	TYPE
MAX40016EVKIT#	EV Kit

#Denotes RoHS compliant.

## MAX40016 EV Kit Bill of Materials

ITEM	REF_DES	DNI/DNP	QTY	MFG PART #	MANUFACTURER	VALUE	DESCRIPTION
1	C8, C11	-	2	GRM31CR71C106KAC7; GRM31CR71C106KA12	MURATA	10µF	CAPACITOR; SMT (1206); CERAMIC CHIP; 10µF; 16V; TOL = 10%; TG = -55°C TO +125°C; TC = X7R
2	C9, C10	-	2	C0603C104K5RAC; C1608X7R1H104K	KEMET; TDK	0.1µF	CAPACITOR; SMT (0603); CERAMIC CHIP; 0.1µF; 50V; TOL = 10%; TG = -55°C TO +125°C; TC = X7R;
3	GND, VDD, LOAD, TP17	-	4	108-0740-001	EMERSON NETWORK POWER	108-0740-001	CONNECTOR; MALE; PANELMOUNT; BANANA JACK; STRAIGHT; 1PIN
4	J1-J6	-	6	5-1634503-1	TE CONNECTIVITY	5-1634503-1	CONNECTOR; FEMALE; THROUGH HOLE; LOW PROFILE BNC PCB SOCKET; STRAIGHT; 5PINS
5	JU0, JU1	-	2	PEC03SAAN	SULLINS	PEC03SAAN	CONNECTOR; MALE; THROUGH HOLE; BREAKAWAY; STRAIGHT; 3PINS
6	JU2-JU5	-	4	PEC02SAAN	SULLINS	PEC02SAAN	CONNECTOR; MALE; THROUGH HOLE; BREAKAWAY; STRAIGHT; 2PINS
7	R1	-	1	RG1608P-161-B	SUSUMU	160	RESISTOR; 0603; 160Ω; 0.1%; 25PPM; 0.1W; THIN FILM
8	R2	-	1	ERA3AEB5361	PANASONIC	5.36K	RESISTOR; 0603; 5.36KΩ; 0.1%; 25PPM; 0.1W; THIN FILM
9	R3	-	1	ERA3AEB164	PANASONIC	160K	RESISTOR; 0603; 160KΩ; 0.1%; 25PPM; 0.1W; THIN FILM
10	R4	-	1	CRCW060310K0FK; ERJ-3EKF1002	VISHAY DALE; PANASONIC	10K	RESISTOR; 0603; 10K; 1%; 100PPM; 0.10W; THICK FILM
11	R5	-	1	CRCW06030000ZS; MCR03EZPJ000; ERJ-3GEY0R00	VISHAY DALE/ROHM/ PANASONIC	0	RESISTOR; 0603; 0Ω; 0%; JUMPER; 0.10W; THICK FILM
12	TP1, TP2, TP4-TP7, TP15, TP16	-	8	5011	KEYSTONE	N/A	TEST POINT; PIN DIA = 0.125IN; TOTAL LENGTH = 0.445IN; BOARD HOLE = 0.063IN; BLACK; PHOSPHOR BRONZE WIRE SILVER PLATE FINISH;
13	U1	-	1	MAX40016ANL+	MAXIM	MAX40016ANL+	EVKIT PART-IC; MAX40016ANL+; PACKAGE OUTLINE: 21-100213; PACKAGE CODE: N151B1+1; WLP15
14	VLD, VDD1, VISH, VISL, VISM, VOUT, VSEL0, VSEL1	-	8	5010	KEYSTONE	N/A	TESTPOINT WITH 1.80MM HOLE DIA, RED, MULTIPURPOSE;
15	PCB	-	1	MAX40016	MAXIM	PCB	PCB:MAX40016
16	C1-C5	DNP	0	C0603C102K5RAC; GRM188R71H102KA01; C0603X7R500-102KNE	KEMET/MURATA/ VENKEL	1000PF	CAPACITOR; SMT; 0603; CERAMIC; 1000pF; 50V; 10%; X7R; -55°C to +125°C; ±15% from -55°C to +125°C
17	C6, C7, C12, C13	DNP	0	GRM31CR71C106KAC7; GRM31CR71C106KA12	MURATA	10µF	CAPACITOR; SMT (1206); CERAMIC CHIP; 10µF; 16V; TOL = 10%; TG = -55°C TO +125°C; TC = X7R
TOTAL			43				

MAX40016 EV Kit Schematic

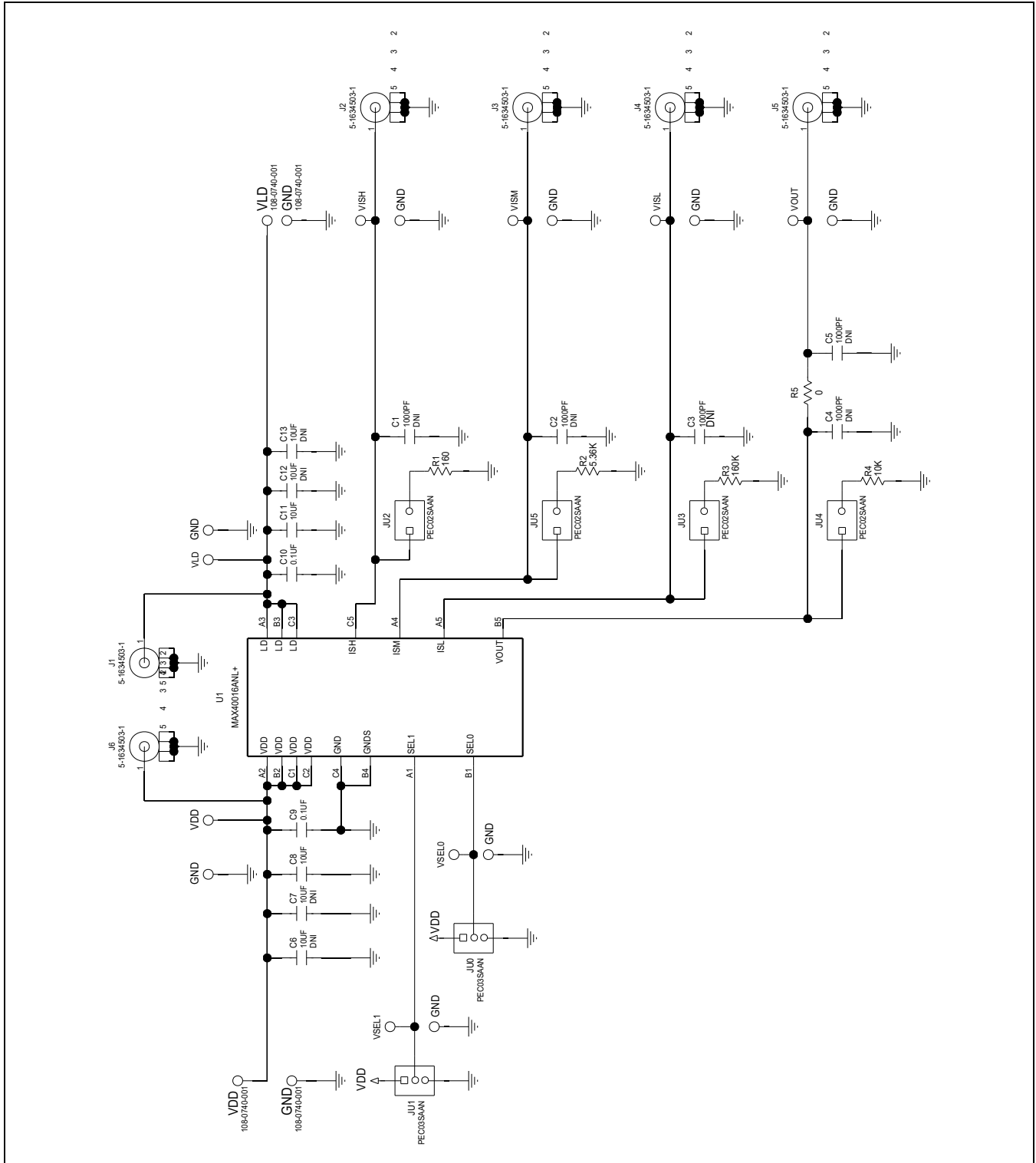

MAX40016 EV Kit PCB Layout Diagrams

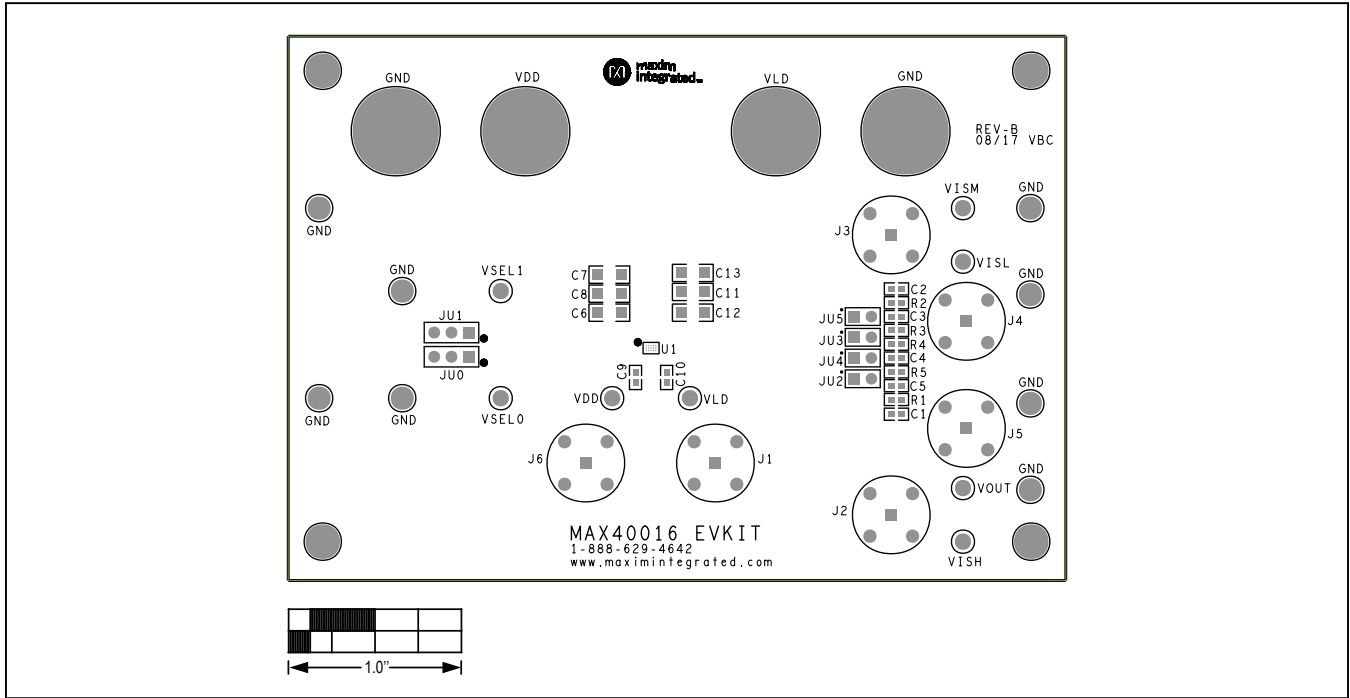

MAX40016 EV Kit PCB Layout—Silkscreen Top Side

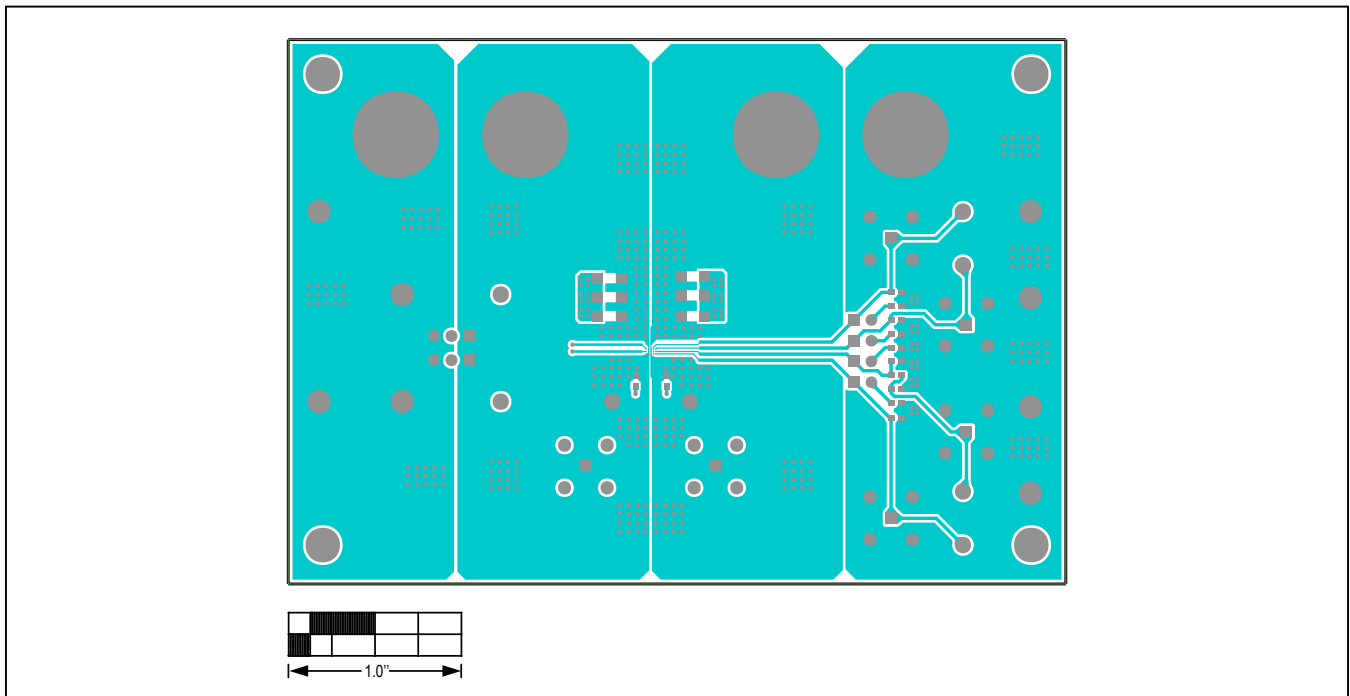

MAX40016 EV Kit PCB Layout—Silkscreen Top Side

MAX40016 EV Kit PCB Layout Diagrams (continued)

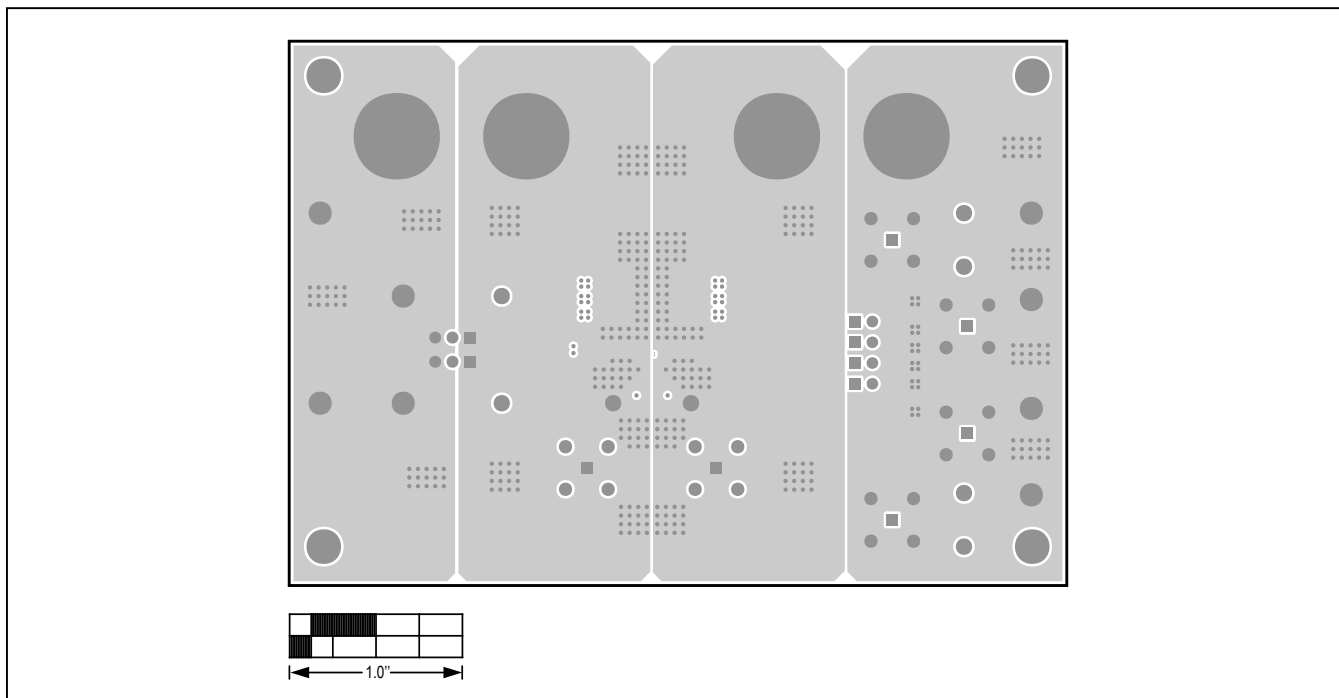

MAX40016 EV Kit PCB Layout—Internal Layer 2

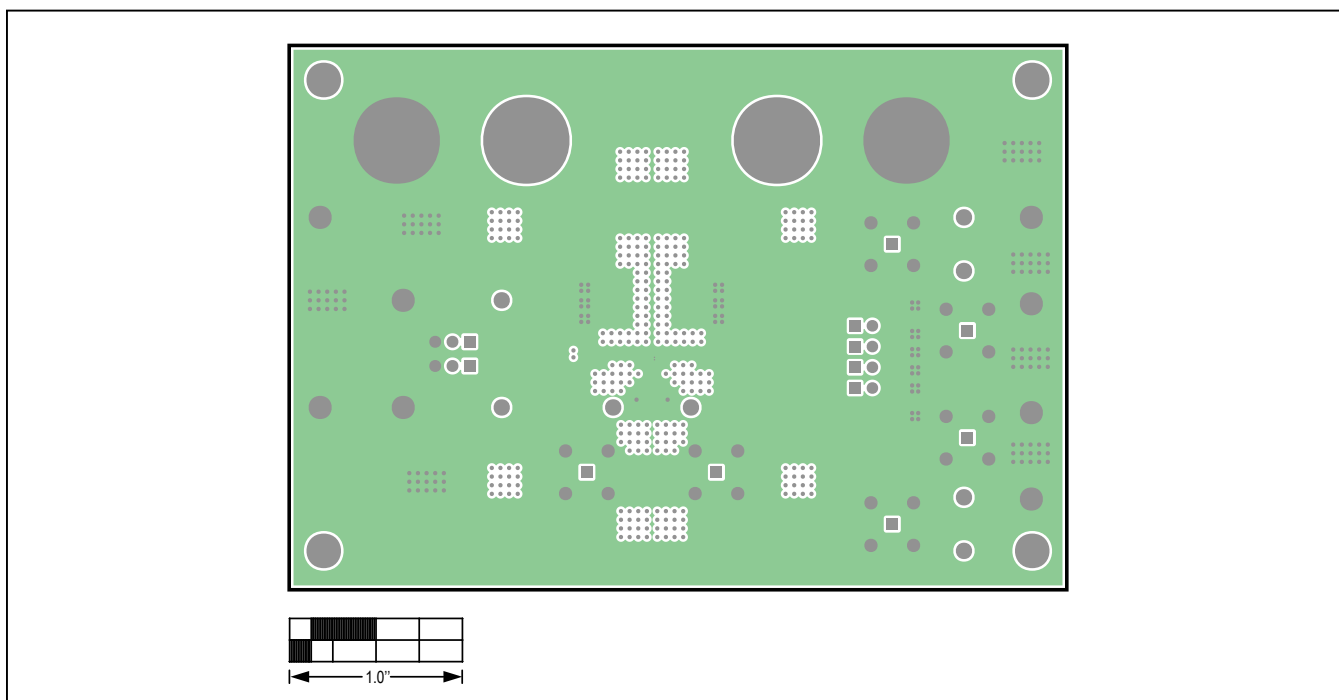

MAX40016 EV Kit PCB Layout—Internal Layer 3

MAX40016 EV Kit PCB Layout Diagrams (continued)

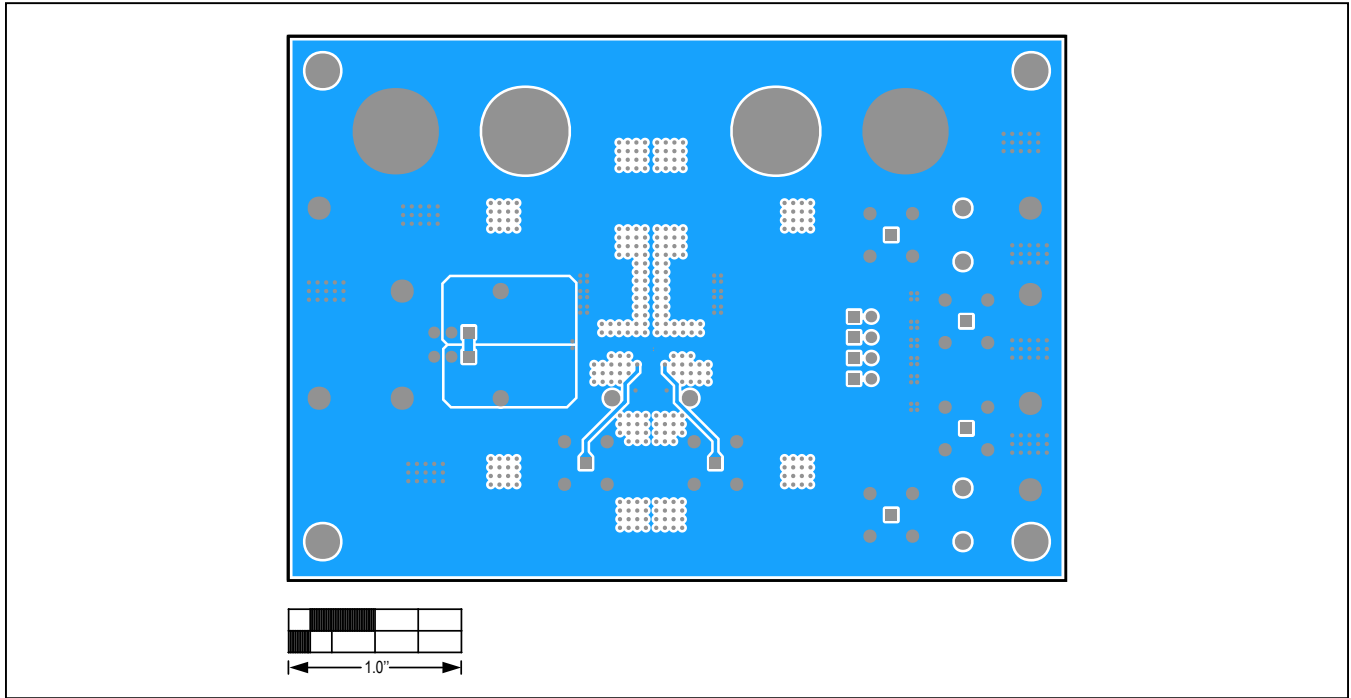

MAX40016 EV Kit PCB Layout—Bottom Side



### Revision History

REVISION NUMBER	REVISION DATE	DESCRIPTION	PAGES CHANGED
0	10/17	Initial release	—

For pricing, delivery, and ordering information, please contact Maxim Direct at 1-888-629-4642, or visit Maxim Integrated's website at [www.maximintegrated.com](http://www.maximintegrated.com).

*Maxim Integrated cannot assume responsibility for use of any circuitry other than circuitry entirely embodied in a Maxim Integrated product. No circuit patent licenses are implied. Maxim Integrated reserves the right to change the circuitry and specifications without notice at any time.*

## X-ON Electronics

Largest Supplier of Electrical and Electronic Components

*Click to view similar products for [Amplifier IC Development Tools](#) category:*

*Click to view products by [Maxim](#) manufacturer:*

Other Similar products are found below :

[AD8033AKS-EBZ](#) [AD8044AR-EBZ](#) [AD744JR-EBZ](#) [AD8023AR-EBZ](#) [AD848JR-EBZ](#) [ADA4922-1ACP-EBZ](#) [EVAL-ADCMP553BRMZ](#)  
[EVAL-ADCMP608BKSZ](#) [MIOP 42109](#) [EVAL-ADCMP609BRMZ](#) [ADA4950-1YCP-EBZ](#) [MAX2634EVKIT](#) [ISL28158EVAL1Z](#) [MADL-](#)  
[011014-001SMB](#) [AD8137YCP-EBZ](#) [EVAL-ADA4523-1ARMZ](#) [EVAL01-HMC1013LP4E](#) [MCP6XXXEV-AMP3](#) [MCP6XXXEV-AMP4](#)  
[MCP6XXXEV-AMP2](#) [ISL28006FH-100EVAL1Z](#) [551012922-001/NOPB](#) [EVAL-ADCMP603BCPZ](#) [AMC1200EVM](#) [AD8417RM-EVALZ](#)  
[DEM-OPA-SOT-1A](#) [DEM-OPA-SO-1C](#) [DEM-BUF-SOT-1A](#) [OPA2836IDGSEVM](#) [AD633-EVALZ](#) [AD8250-EVALZ](#) [AD8418R-EVALZ](#)  
[ISL28433SOICEVAL1Z](#) [ISL28233SOICEVAL1Z](#) [ISL28208SOICEVAL2Z](#) [ISL28207SOICEVAL2Z](#) [ISL28006FH-50EVAL1Z](#)  
[ISL28005FH-50EVAL1Z](#) [120257-HMC613LC4B](#) [DC1591A](#) [DC1150A](#) [DC1115A](#) [DC954A-C](#) [DC306A-A](#) [DC1192A](#) [131679-](#)  
[HMC813LC4B](#) [OPA2835IDGSEVM](#) [LMH730220/NOPB](#) [MAAP-011246-1SMB](#) [118329-HMC627ALP5](#)