

General Description

The MAX40018 evaluation kit (EV kit) provides a proven design to evaluate the MAX40018 low power, rail-to-rail dual-operational amplifiers (op amps) in an 8-bump (1.63mm x 0.91mm x 0.5mm) wafer-level package (WLP). The EV kit circuit is preconfigured as noninverting amplifiers, but can be adapted to other topologies by changing a few components.

The EV kit comes with a MAX40018ANA+ installed.

Features

- Accommodates Multiple Op-Amp Configurations
- Accommodates Easy-to-Use Components
- Proven PCB Layout
- Fully Assembled and Tested

Ordering Information appears at end of data sheet.

MAX40018 EV Kit Photo

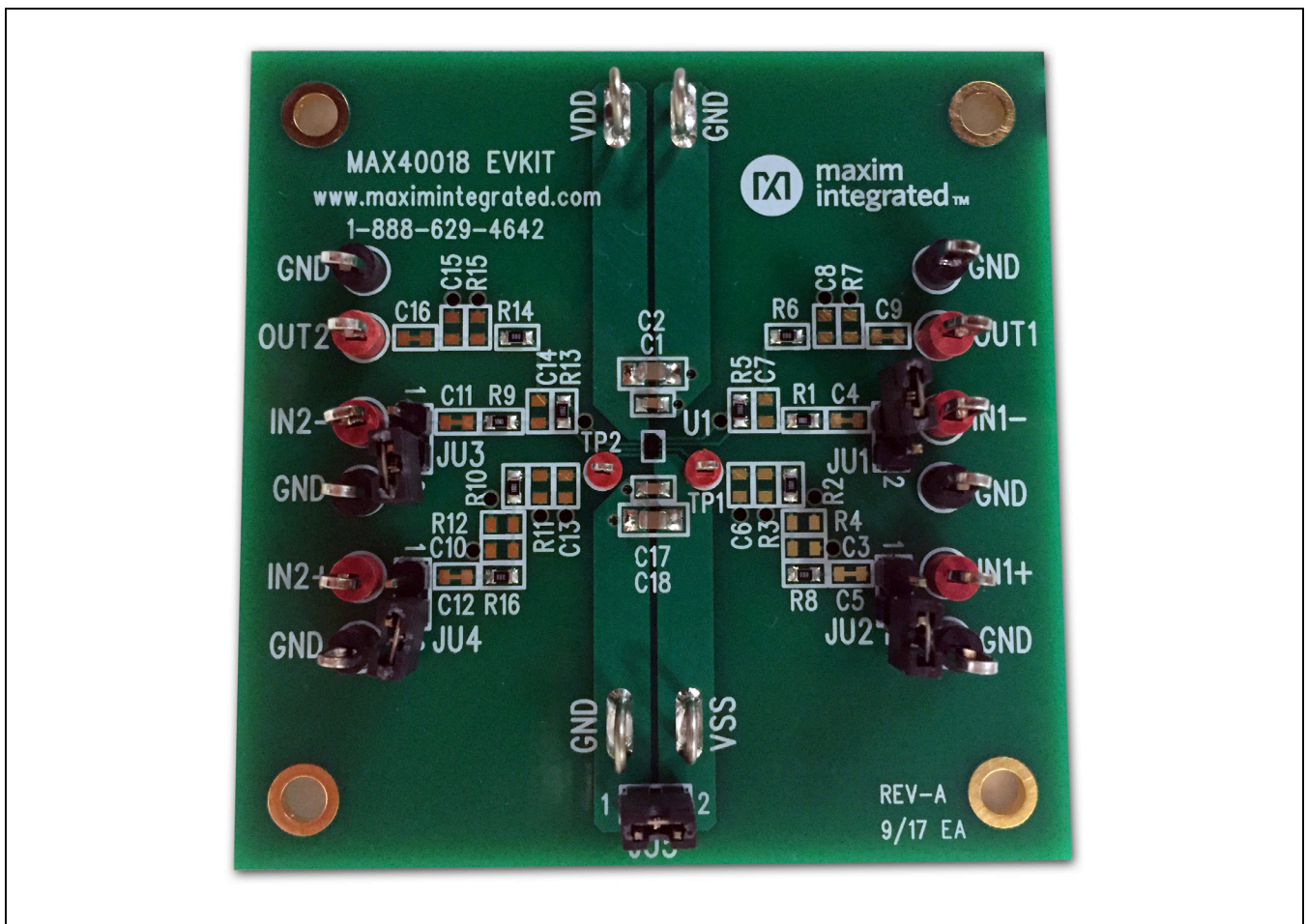

Quick Start

Required Equipment

- MAX40018 EV kit
- +5V, 10mA DC power supply (PS1)
- Two precision voltage sources
- Two digital multimeters (DMMs)

Procedure

The EV kit is fully assembled and tested. Follow the steps below to verify board operation:

- 1) Verify that all jumpers (JU1–JU5) are in their default positions, as shown in [Table 1](#).
- 2) Connect the positive terminal of the +5V supply to VDD and the negative terminal to GND and VSS.
- 3) Connect the positive terminal of the precision voltage source to IN1+. Connect the negative terminal of the precision voltage source to GND. IN1- is already connected to GND through jumper JU1.
- 4) Connect the positive terminal of the second precision voltage source to the IN2+ test point. Connect the negative terminal of the precision voltage source to GND. IN2- is already connected to GND through jumper JU3.
- 5) Connect the DMMs to monitor the voltages on OUT1 and OUT2. With the 10kΩ feedback resistors and 1kΩ series resistors, the gain of each noninverting amplifier is +11.
- 6) Turn on the +5V power supply.
- 7) Apply 100mV from the precision voltage sources. Observe the output at OUTA and OUTB on the DMMs. Both should read approximately +1.1V.
- 8) Apply 400mV from the precision voltage sources. Both OUT1 and OUT2 should read approximately +4.4V.

Note: For dual-supply operation, a ±0.85V to ±2.75V can be applied to VDD and VSS, respectively. In this case, remove the shunt on jumper JU5. The rest of the procedure remains the same as that of the single-supply operation.

Detailed Description of Hardware

The MAX40018 EV kit provides a proven layout for the MAX40018 ultra-precision, low-noise, low-drift, dual op amp. The device is a single/dual-supply, dual op amp (op amp 1 and op amp 2) that is ideal for ADC buffers.

The default configuration for the device in the EV kit is single-supply operation in noninverting configuration. However, the device can operate with a dual supply as long as the voltage across the VDD and VSS pins of the IC do not exceed the absolute maximum ratings. When operating with a single supply, short VSS to GND using jumper JU5.

Op-Amp Configurations

The device is a single/dual-supply dual op amp that is ideal for differential sensing, noninverting amplification, buffering, and filtering. A few common configurations are shown in the next few sections.

The following sections explain how to configure one of the device's op amps (op amp 1). To configure the device's second op amp (op amp 2), the same equations can be used after modifying the component reference designators.

Noninverting Configuration

The EV kit comes preconfigured as a noninverting amplifier. The gain is set by the ratio of R5 and R1. The EV kit comes preconfigured for a gain of +11. The output voltage for the noninverting configuration is given by the equation below:

$$V_{OUT1} = \left(1 + \frac{R5}{R1}\right) [V_{IN1+} \pm V_{OS}]$$

Inverting Configuration

To configure the EV kit as an inverting amplifier, remove the shunt on jumper JU1 and install a shunt on jumper JU2 and feed an input signal on the IN1- test point.

Differential Amplifier

To configure the EV kit as a differential amplifier, replace R1–R3 and R5 with appropriate resistors. When R1 = R2 and R3 = R5, the CMRR of the differential amplifier is determined by the matching of the resistor ratios R1/R2 and R3/R5.

$$V_{OUT1} = GAIN \times (V_{IN1+} - V_{IN1-})$$

where:

$$GAIN = \frac{R5}{R1} = \frac{R3}{R2}$$

Capacitive Loads

Some applications require driving large capacitive loads. The EV kit provides C8 and R6 pads for optional capacitive-load driving circuit. C8 simulates the capacitive load while R6 acts as an isolation resistor to improve the op-amp’s stability at higher capacitive loads. To improve the stability of the amplifier in such cases, replace R6 with a suitable resistor value to improve amplifier phase margin.

Table 1. Jumper Descriptions (JU1–JU5)

JUMPER	SHUNT POSITION	DESCRIPTION
JU1	Pin 1	Disconnects IN1- from GND.
	1-2*	Connects IN1- to GND through R1 for noninverting configuration.
JU2	Pin 1*	Disconnects IN1+ from GND.
	1-2	Connects IN1+ to GND through R2.
JU3	Pin 1	Disconnects IN2- from GND.
	1-2*	Connects IN2- to GND through R9 for noninverting configuration.
JU4	Pin 1*	Disconnects IN2+ from GND.
	1-2	Connects IN2+ to GND through R10.
JU5	Pin 1	VSS and GND are independently supplied for dual-supply operation.
	1-2*	Connects VSS to GND for single-supply operation.

*Default position.

Ordering Information

PART	TYPE
MAX40018EVKIT#	EV Kit

#Denotes RoHS compliant.

MAX40018 EV Kit Bill of Materials

ITEM	REF_DES	DNI/DNP	QTY	MFG PART #	MANUFACTURER	VALUE	DESCRIPTION	COMMENTS
1	C1, C17	-	2	GRM21BR71H104K	MURATA	0.1UF	CAPACITOR; SMT (0603); CERAMIC CHIP; 0.1UF; 50V; TOL=10%; TG=-55 DEGC TO +125 DEGC; TC=X7R	
2	C2, C18	-	2	GRM31CR71H475K	MURATA	4.7UF	CAPACITOR; SMT (1206); CERAMIC CHIP; 4.7UF; 50V; TOL=10%; TG=-55 DEGC TO +125 DEGC; TC=X7R;	
3	JU1-JU5	-	5	PCC02SAAN	SULLINS	PCC02SAAN	CONNECTOR; MALE; THROUGH HOLE; BREAKAWAY; STRAIGHT THROUGH; 2PINS; -65 DEGC TO +125 DEGC	
4	R1, R2, R9, R10	-	4	N/A	N/A	1K	RESISTOR; 0603; 1K; 1%; 100PPM; 0.10W; THICK FILM	
5	R5, R13	-	2	N/A	N/A	10K	RESISTOR; 0603; 10K; 1%; 100PPM; 0.10W; THICK FILM	
6	R6, R8, R14, R16	-	4	N/A	N/A	0	RESISTOR; 0603; 0Ω; 5%; JUMPER; 0.10W; THICK FILM	
7	IN1+, IN1-, OUT1, IN2+, IN2-, OUT2	DNP	6	5010	KEYSTONE	N/A	RED MULTIPURPOSE TESTPOINT	
8	TP1, TP2	-	2	5000	KEYSTONE	N/A	MINIATURE TESTPOINTS	
9		-	5	-----	ANY	SHUNT	SHUNTS	
10	U1	-	1	MAX40018ANA+	MAXIM	MAX40018ANA+	EVKIT PART-IC; MAX40016ANA+	
11	PCB	-	1	MAX40018	MAXIM	PCB	PCB: MAX40018 EVALUATION KIT	
12	C4, C5, C19, C11, C12, C16	DNP	0	N/A	N/A	SHORT	Not installed, ceramic capacitor (0603)	
13	C3, C6, C7, C8, C10, C13, C14, C15	DNP	0	N/A	N/A	OPEN	Not installed, ceramic capacitor (0603)	
14	R3, R4, R7, R11, R12, R15	DNP	0	N/A	N/A	OPEN	Not installed, resistor (0603)	
TOTAL			34					

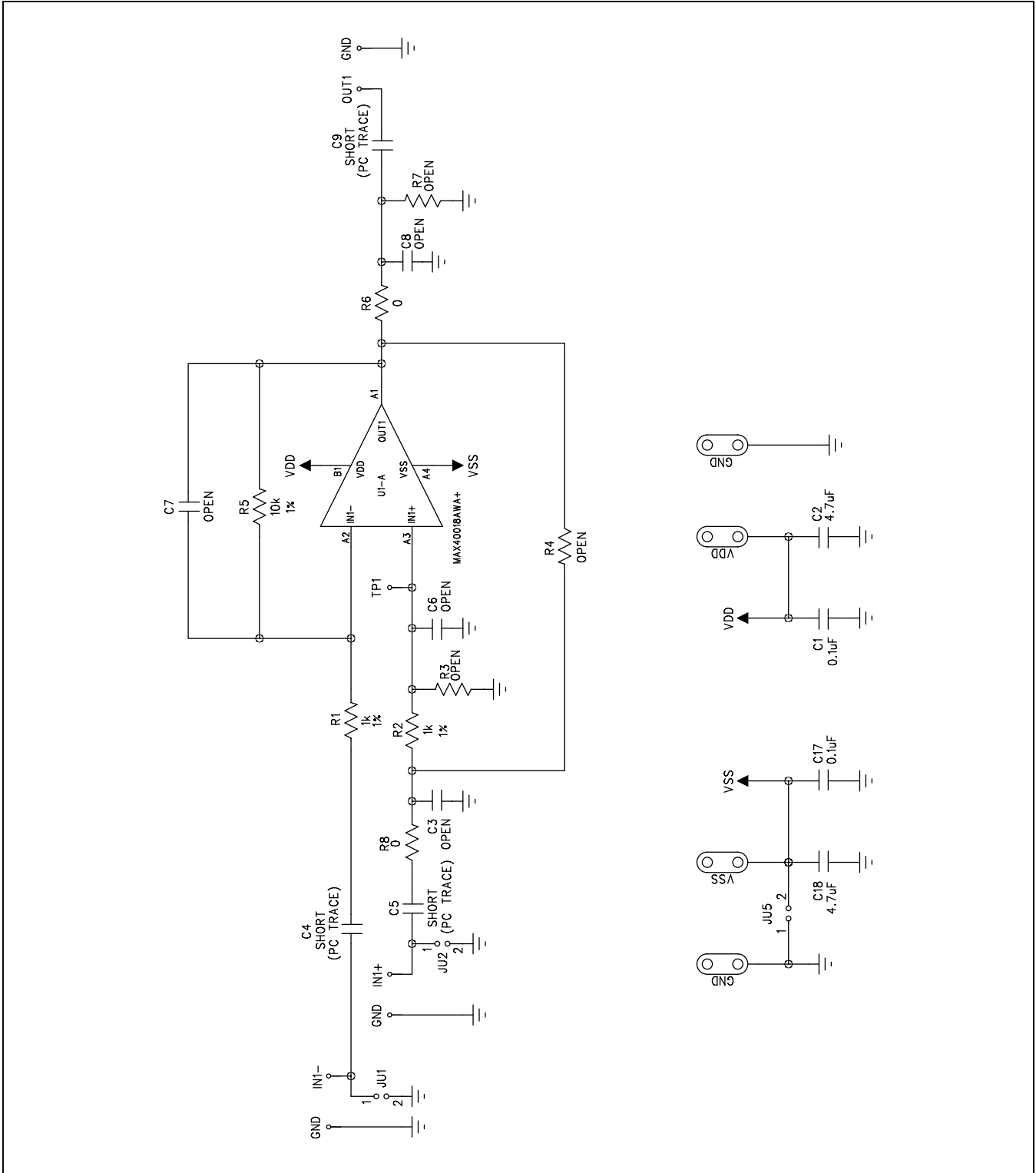

Figure 1a. MAX40018 EV Kit Schematic (Sheet 1 of 2)

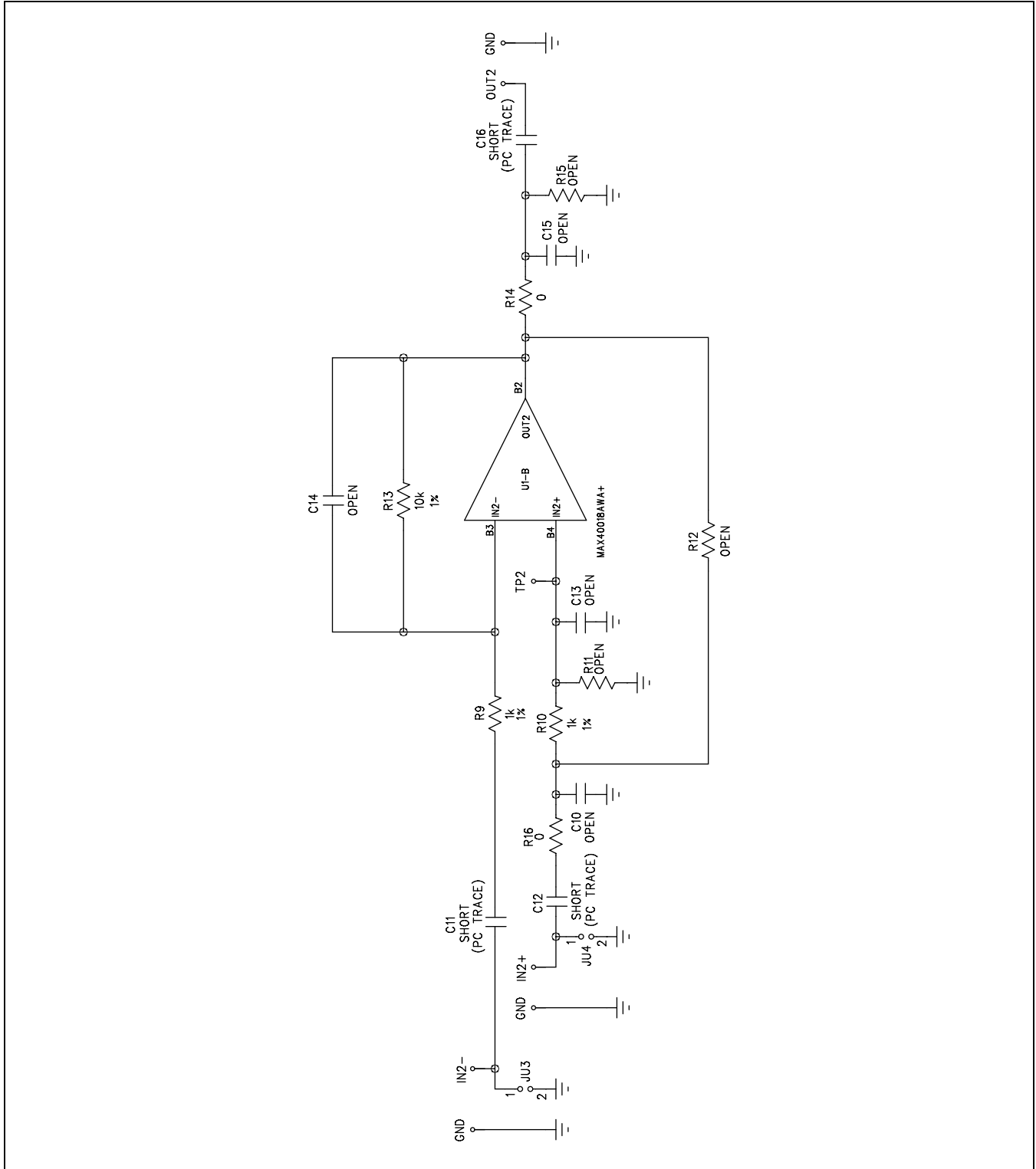

Figure 1b. MAX40018 EV Kit Schematic (Sheet 2 of 2)

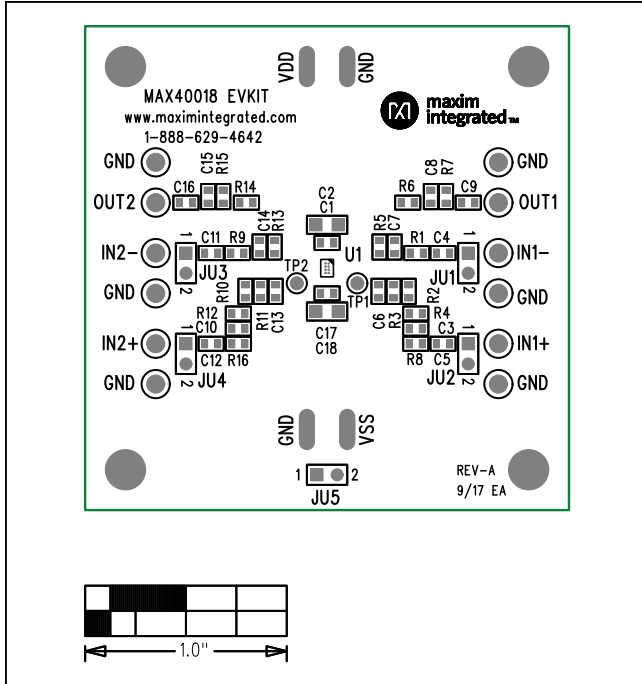

Figure 2. MAX40018 EV Kit Component Placement Guide—Component Side

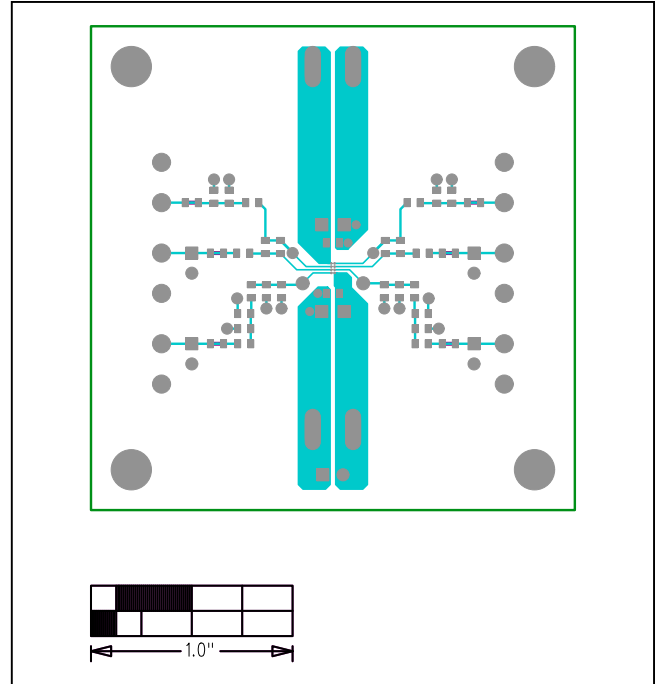

Figure 3. MAX40018 EV Kit PCB Layout—Component Side

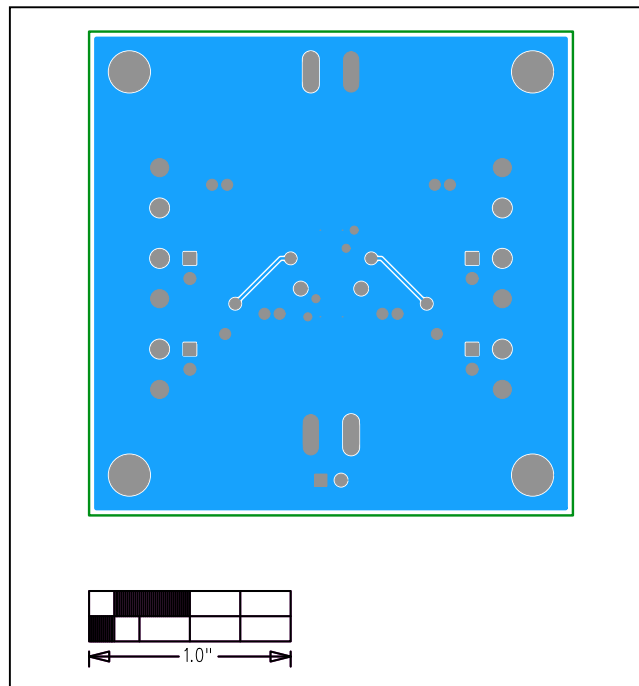

Figure 4. MAX40018 EV Kit PCB Layout—Solder Side

Revision History

REVISION NUMBER	REVISION DATE	DESCRIPTION	PAGES CHANGED
0	1/18	Initial release	—

For pricing, delivery, and ordering information, please contact Maxim Direct at 1-888-629-4642, or visit Maxim's website at www.maximintegrated.com.

Maxim Integrated cannot assume responsibility for use of any circuitry other than circuitry entirely embodied in a Maxim Integrated product. No circuit patent licenses are implied. Maxim Integrated reserves the right to change the circuitry and specifications without notice at any time. The parametric values (min and max limits) shown in the Electrical Characteristics table are guaranteed. Other parametric values quoted in this data sheet are provided for guidance.

X-ON Electronics

Largest Supplier of Electrical and Electronic Components

Click to view similar products for [Amplifier IC Development Tools](#) category:

Click to view products by [Maxim](#) manufacturer:

Other Similar products are found below :

[AD8033AKS-EBZ](#) [AD8044AR-EBZ](#) [AD744JR-EBZ](#) [AD8023AR-EBZ](#) [AD848JR-EBZ](#) [ADA4922-1ACP-EBZ](#) [EVAL-ADCMP553BRMZ](#)
[EVAL-ADCMP608BKSZ](#) [MIOP 42109](#) [EVAL-ADCMP609BRMZ](#) [ADA4950-1YCP-EBZ](#) [MAX2634EVKIT](#) [ISL28158EVAL1Z](#) [MADL-](#)
[011014-001SMB](#) [AD8137YCP-EBZ](#) [EVAL-ADA4523-1ARMZ](#) [EVAL01-HMC1013LP4E](#) [MCP6XXXEV-AMP3](#) [MCP6XXXEV-AMP4](#)
[MCP6XXXEV-AMP2](#) [ISL28006FH-100EVAL1Z](#) [551012922-001/NOPB](#) [EVAL-ADCMP603BCPZ](#) [AMC1200EVM](#) [AD8417RM-EVALZ](#)
[DEM-OPA-SOT-1A](#) [DEM-OPA-SO-1C](#) [DEM-BUF-SOT-1A](#) [OPA2836IDGSEVM](#) [AD633-EVALZ](#) [AD8250-EVALZ](#) [AD8418R-EVALZ](#)
[ISL28433SOICEVAL1Z](#) [ISL28233SOICEVAL1Z](#) [ISL28208SOICEVAL2Z](#) [ISL28207SOICEVAL2Z](#) [ISL28006FH-50EVAL1Z](#)
[ISL28005FH-50EVAL1Z](#) [120257-HMC613LC4B](#) [DC1591A](#) [DC1150A](#) [DC1115A](#) [DC954A-C](#) [DC306A-A](#) [DC1192A](#) [131679-](#)
[HMC813LC4B](#) [OPA2835IDGSEVM](#) [LMH730220/NOPB](#) [MAAP-011246-1SMB](#) [118329-HMC627ALP5](#)