

Click [here](#) to ask about the production status of specific part numbers.

MAX40079/MAX40087/ MAX40077/MAX40089/ MAX40078

Single/Dual/Quad Ultra-Low Input Bias Current, Low-Noise Amplifiers

General Description

The MAX40079/MAX40087/MAX40077/MAX40089/MAX40078 are wide band, low-noise, low-input bias current operational amplifiers that offer rail-to-rail outputs and single-supply operation from 2.7V to 5.5V. These low-noise amps draw 2.2mA of quiescent supply current per amplifier. This family of amplifiers offers ultra-low distortion (0.0002% THD+N), as well as low input voltage-noise density ($4.2\text{nV}/\sqrt{\text{Hz}}$) and low input current-noise density ($0.5\text{fA}/\sqrt{\text{Hz}}$). The low input bias current of 0.3pA (typ) and low noise ($4.5\text{nV}/\sqrt{\text{Hz}}$), together with the wide bandwidth, provides excellent performance for transimpedance (TIA) and imaging applications.

These amplifiers have outputs which swing rail-to-rail and their input common-mode voltage range includes ground. The MAX40079/MAX40077/MAX40078 are single/dual/quad respectively in unity-gain stable with a bandwidth of 10MHz. The MAX40087/MAX40089 are single/dual respectively with gain ≥ 5 stable and bandwidth of 42MHz. They operate over the full -40°C to $+125^{\circ}\text{C}$ temperature range.

Single channel op amps are available in 6-bump wafer-level package (WLP) and SOT23 6-pin packages. The dual channel op amps are available in 8-bump WLP and $\mu\text{MAX-8}$ packages. The quad channel option is available in 14-TSSOP package.

Applications

- Transimpedance Amplifiers
- pH Probes and Reference Electrodes
- ADC Buffers
- DAC Output Amplifiers
- Low-Noise Microphone/Preamplifiers
- Digital Scales
- Strain Gauges/Sensor Amplifiers
- Medical Instrumentation

Ordering Information appears at end of data sheet.

Benefits and Features

- Low Input Voltage Noise Density: $4.2\text{nV}/\sqrt{\text{Hz}}$ at 30KHz
- Low Input Current Noise Density: $0.5\text{fA}/\sqrt{\text{Hz}}$
- Low Input Bias Current: 0.3pA (typ)
- Low Distortion: 0.00035% or -109dB THD+N (1k Ω Load)
- Single-Supply Operation from +2.7V to +5.5V
- Input Common-Mode Voltage Range Includes Ground
- Rail-to-Rail Output Swings with a 1k Ω Load
- Wide Bandwidth: MAX40079/MAX40077/MAX40078 (10MHz); MAX40087/MAX40089 (42MHz)
- Excellent DC Characteristics: $V_{OS} \leq 30\mu\text{V}$
- Single-Channel 6-bump WLP in 1.31mm x 0.73mm with 0.35mm Bump Pitch
- Dual-Channel 8-bump WLP in 0.96mm x 1.66mm with 0.35mm Bump Pitch
- Available in Space-Saving 6-WLP, 6-SOT, 8-WLP and μMAX Packages

THD+N Performance

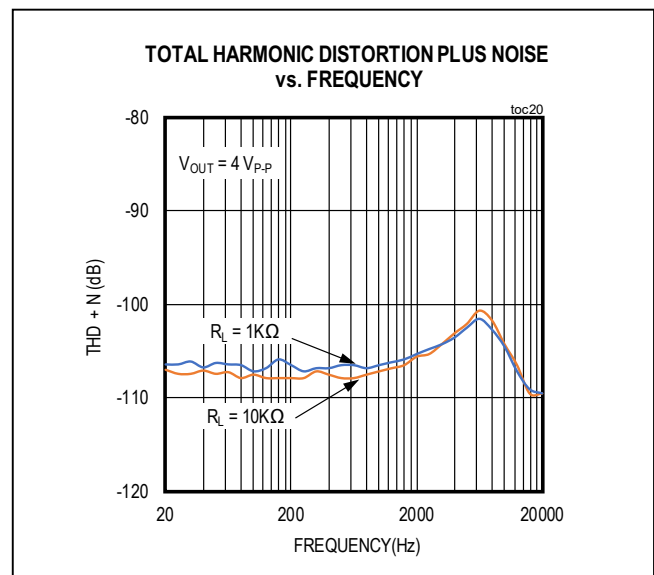

MAX40079/MAX40087/
MAX40077/MAX40089/
MAX40078

Single/Dual/Quad Ultra-Low
Input Bias Current, Low-Noise Amplifiers

Absolute Maximum Ratings

Input Differential Voltage(IN+ - IN-) MAX40079/MAX40087/MAX40077/MAX40089/MAX40078 (continuous).....-3V to +3V MAX40079/MAX40087/MAX40077/MAX40089/MAX40078 (transient, 10s).....-6V to +6V	Operating Temperature Range..... -40°C to +125°C Continuous Power Dissipation (T _A = +70°C) SOT23-6 (derate 8.7mW/°C above +70°C).....696mW 6-Bump WLP (derate 10.19mW/°C above +70°C).....815mW 8-μMAX (derate 4.8mW/°C above +70°C)387.80mW 8-Bump WLP (derate 10.90mW/°C above +70°C).....872mW 14-TSSOP (derate 10mW/°C above +70°C).....796.80mW
Power-Supply Voltage (V _{DD} to V _{SS}).....-0.3V to +6V Analog Input Voltage (IN+,IN-) to V _{SS}).....V _{SS} - 0.3V to V _{DD} + 0.3V	Storage Temperature Range -65°C to +150°C Lead Temperature ((soldering, 10s))..... +300°C Soldering Temperature (reflow)..... +260°C
SHDN Input Voltage (to V _{SS}).....V _{SS} - 0.3V to +6V Continuous Input Current (IN+,IN-) ±20mA Output Short-Circuit Duration to Either Supply Continuous	

Stresses beyond those listed under "Absolute Maximum Ratings" may cause permanent damage to the device. These are stress ratings only, and functional operation of the device at these or any other conditions beyond those indicated in the operational sections of the specifications is not implied. Exposure to absolute maximum rating conditions for extended periods may affect device reliability.

Package Information

6-SOT23

PACKAGE CODE	U6+1
Outline Number	21-0058
Land Pattern Number	90-0175
Thermal Resistance, Four-Layer Board:	
Junction to Ambient (θ _{JA})	115°C/W
Junction to Case (θ _{JC})	80°C/W

6-WLP

PACKAGE CODE	N60F1+1
Outline Number	21-100174
Land Pattern Number	Refer to Application Note 1891
Thermal Resistance, Four-Layer Board:	
Junction to Ambient (θ _{JA})	98.06°C/W
Junction to Case (θ _{JC})	N/A

8-μMAX

PACKAGE CODE	U8+1
Outline Number	21-0036
Land Pattern Number	90-0092
Thermal Resistance, Single-Layer Board:	
Junction to Ambient (θ _{JA})	221°C/W
Junction to Case (θ _{JC})	42°C/W
Thermal Resistance, Four-Layer Board:	
Junction to Ambient (θ _{JA})	206.30°C/W
Junction to Case (θ _{JC})	42°C/W

MAX40079/MAX40087/
MAX40077/MAX40089/
MAX40078

Single/Dual/Quad Ultra-Low
Input Bias Current, Low-Noise Amplifiers

Package Information (continued)

8-WLP

PACKAGE CODE	N80C1+1
Outline Number	21-100236
Land Pattern Number	Refer to Application Note 1891
Thermal Resistance, Four-Layer Board:	
Junction to Ambient (θ_{JA})	91.72°C/W
Junction to Case (θ_{JC})	N/A

14-TSSOP

PACKAGE CODE	U14M+1
Outline Number	21-0066
Land Pattern Number	90-0113
Thermal Resistance, Single-Layer Board:	
Junction to Ambient (θ_{JA})	110°C/W
Junction to Case (θ_{JC})	30°C/W
Thermal Resistance, Four-Layer Board:	
Junction to Ambient (θ_{JA})	100.4°C/W
Junction to Case (θ_{JC})	30°C/W

For the latest package outline information and land patterns (footprints), go to www.maximintegrated.com/packages. Note that a "+", "#", or "-" in the package code indicates RoHS status only. Package drawings may show a different suffix character, but the drawing pertains to the package regardless of RoHS status.

Package thermal resistances were obtained using the method described in JEDEC specification JESD51-7, using a four-layer board. For detailed information on package thermal considerations, refer to www.maximintegrated.com/thermal-tutorial.

MAX40079/MAX40087/
 MAX40077/MAX40089/
 MAX40078

Single/Dual/Quad Ultra-Low
 Input Bias Current, Low-Noise Amplifiers

Package Information (continued)

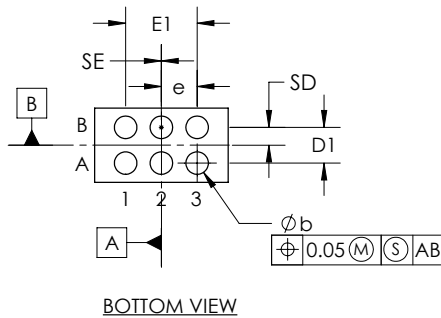
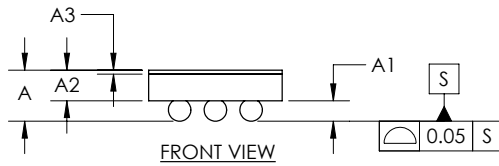
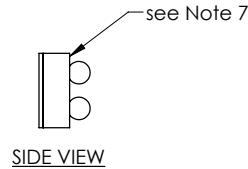
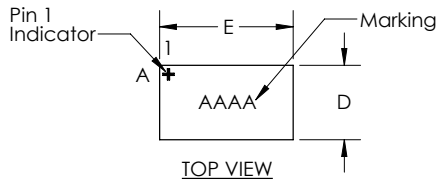

COMMON DIMENSIONS	
A	0.50 MAX
A1	0.17 ±0.03
A2	0.30 REF
A3	0.040 BASIC
b	∅0.22 ±0.03
D	0.727 ±0.025
E	1.308 ±0.025
D1	0.35 BASIC
E1	0.70 BASIC
e	0.35 BASIC
SD	0.175 BASIC
SE	0.00 BASIC
DEPOPULATED BUMPS: NONE	

- NOTES:
1. Terminal pitch is defined by terminal center to center value.
 2. Outer dimension is defined by center lines between scribe lines.
 3. All dimensions in millimeter.
 4. Marking shown is for package orientation reference only.
 5. Tolerance is ± 0.02 unless specified otherwise.
 6. All dimensions apply to PbFree (+) package codes only.
 7. Front - side finish can be either Black or Clear.

- DRAWING NOT TO SCALE -

TITLE PACKAGE OUTLINE 6 BUMPS THIN WLP PKG. 0.35 mm PITCH,N60F1+1		
APPROVAL	DOCUMENT CONTROL NO. 21-100174	REV. A 1/1

MAX40079/MAX40087/
MAX40077/MAX40089/
MAX40078

Single/Dual/Quad Ultra-Low
Input Bias Current, Low-Noise Amplifiers

Electrical Characteristics

($V_{DD} = +5V$, $V_{SS} = 0V$, $V_{CM} = 2.5V$, $\overline{SHDN} = V_{DD}$, $V_{OUT} = V_{DD}/2$, $R_L = 10k\Omega = \text{tied to } V_{DD}/2$, $T_A = -40^\circ C$ to $+125^\circ C$, unless otherwise noted. Typical values are at $T_A = +25^\circ C$. (Note 1))

PARAMETER	SYMBOL	CONDITIONS	MIN	TYP	MAX	UNITS
Supply Voltage Range	V_{DD}	Guaranteed by PSRR test	2.7		5.5	V
Quiescent Supply Current, per Amplifier	I_{DD}	$V_{DD} = 3.3V$ ($T_A = 25^\circ C$ only)		2.2	2.9	mA
		$V_{DD} = 5V$, over temperature to $125^\circ C$		2.5	3.8	
Power-Up Time		$V_{DD} = 0$ to $5V$ step, $V_{OUT} = 2.5V \pm 1\%$		13		μs
Input Offset Voltage	V_{OS}	at $25^\circ C$		30	350	μV
		Over the full temperature range			750	
Input Offset Drift	V_{OS-TC}	Over temperature, to $125^\circ C$		0.3	6	$\mu V/^\circ C$
Input Bias Current (Note 2)	I_B			0.3	260	pA
Input Offset Current (Note 2)	I_{OS}			0.1	150	pA
Input Resistance	R_{IN}			1000		G Ω
Input Capacitance	C_{IN}	Either input, over entire CMIR		7		pF
Input Common Mode Range	V_{IN+}, V_{IN-}	Guaranteed by CMRR test at $25^\circ C$	-0.2		$V_{DD} - 1.5$	V
		Guaranteed by CMRR test, $-40^\circ C$ to $+125^\circ C$	-0.1		$V_{DD} - 1.5$	
Common Mode Rejection Ratio	CMRR	DC, $-0.2V < V_{IN+}, V_{IN-} < V_{DD} - 1.5V$, at $25^\circ C$	90	120		dB
		DC, $-0.1V < V_{IN+}, V_{IN-} < V_{DD} - 1.5V$, $-40^\circ C$ to $+125^\circ C$	87			
		AC, $100mV_{PP}$ at $10kHz$, DC in $0V$ to $V_{DD} - 2V$ range		60		
Power Supply Rejection Ratio, DC	PSRR	DC, $2.7V < V_{DD} < 5.5V$	90	120		dB
Power Supply Rejection Ratio, AC	PSRR	AC, $100mV_{PP}$ at $1MHz$ with $V_{DD} = 5V$ DC offset		40		dB
Open-Loop Gain	A_{OL}	$R_L = 10K\Omega$ to $V_{DD}/2$, $V_{OUT} = 200mV$ to $V_{DD} - 250mV$	90	120		dB
		$R_L = 1k\Omega$ to $V_{DD}/2$, $V_{OUT} = 200mV$ to $V_{DD} - 250mV$	85	110		
		$R_L = 50\Omega$ to $V_{DD}/2$, $V_{OUT} = 200mV$ to $V_{DD} - 250mV$	85	110		
Output Voltage Swing High (V_{OH})	$V_{DD}-V_{OH}$	$R_L = 10K\Omega$ to $V_{DD}/2$, $V_{DD} - V_{OH}$		10	45	mV
		$R_L = 1K\Omega$ to $V_{DD}/2$, $V_{DD} - V_{OH}$		80	200	
		$R_L = 500\Omega$ to $V_{DD}/2$, $V_{DD} - V_{OH}$		100	300	
Output Voltage Swing Low (V_{OL})	V_{OL}	$R_L = 10K\Omega$ to $V_{DD}/2$, $V_{OL} - V_{SS}$		10	40	mV
		$R_L = 1K\Omega$ to $V_{DD}/2$, $V_{OL} - V_{SS}$		50	150	
		$R_L = 500\Omega$ to $V_{DD}/2$, $V_{OL} - V_{SS}$		80	250	
Short-Circuit Current	I_{SC}	To either V_{DD} or V_{SS}		50		mA

MAX40079/MAX40087/
MAX40077/MAX40089/
MAX40078

Single/Dual/Quad Ultra-Low
Input Bias Current, Low-Noise Amplifiers

Electrical Characteristics (continued)

($V_{DD} = +5V$, $V_{SS} = 0V$, $V_{CM} = 2.5V$, $\overline{SHDN} = V_{DD}$, $V_{OUT} = V_{DD}/2$, $R_L = 10k\Omega = \text{tied to } V_{DD}/2$, $T_A = -40^\circ C$ to $+125^\circ C$, unless otherwise noted. Typical values are at $T_A = +25^\circ C$. (Note 1))

PARAMETER	SYMBOL	CONDITIONS	MIN	TYP	MAX	UNITS
Gain Bandwidth Product	GBWP	Unity Gain, $A_V = +1$ (MAX40079/MAX40077/ MAX40078)		10		MHz
		Min Gain version, $A_V = +5$ (MAX40087/ MAX40089)		42		
Phase Margin	Φ_m	Unity Gain version, $A_V = +1$		70		°
		Minimum Gain, $A_V = +5$ version		80		
Gain Margin	GM			12		dB
Slew Rate	SR	Unity Gain version, $A_V = +1$		3		V/ μs
		Minimum Gain, $A_V = +5$ version		10		
Settling Time		Unity gain version, $A_V = +1$, to 0.01%, $V_{OUT} = 2V$ step		2		μs
		Minimum gain, $A_V = +5$, to 0.01%, $V_{OUT} = 2V$ step		2		
Stable Capacitive Load	C_{LOAD}	No sustained oscillation		50		pF
Integrated 1/f Input Voltage Noise	V_n	0.1Hz to 10Hz		1.7		μV_{PP}
Input Voltage Noise Density	e_N	f = 10Hz		260		nV/ \sqrt{Hz}
		f = 1kHz		5.5		
		f = 30kHz		4.2		
Input Current Noise density	i_N	f = 1kHz		0.5		fA/ \sqrt{Hz}
Total Harmonic Distortion + Noise ($A_V = +1$ stable)	THD+N	Unity gain, $A_V = +1$, $V_{OUT} = 4V_{PP}$ at 1kHz, $R_L = 10k\Omega$ to GND		114		dB
		Unity gain, $A_V = +1$, $V_{OUT} = 4V_{PP}$ at 20kHz, $R_L = 10k\Omega$ to GND		103		
		Unity gain, $A_V = +1$, $V_{OUT} = 4V_{PP}$ at 1kHz, $R_L = 1k\Omega$ to GND		114		
		Unity gain, $A_V = +1$, $V_{OUT} = 4V_{PP}$ at 20kHz, $R_L = 1k\Omega$ to GND		100		
Total Harmonic Distortion + Noise (Min $A_V = +5$ stable)	THD+N	Unity gain, $A_V = +5$, $V_{OUT} = 4V_{PP}$ at 1kHz, $R_L = 10k\Omega$ to GND		108		dB
		Unity gain, $A_V = +5$, $V_{OUT} = 4V_{PP}$ at 20kHz, $R_L = 10k\Omega$ to GND		110		
		Unity gain, $A_V = +5$, $V_{OUT} = 4V_{PP}$ at 1kHz, $R_L = 1k\Omega$ to GND		106		
		Unity gain, $A_V = +5$, $V_{OUT} = 4V_{PP}$ at 20kHz, $R_L = 1k\Omega$ to GND		110		
ElectroMagnetic Interference Rejection Ratio	EMIRR	$V_{RF_PP} = 100mV$, $f_{IN} = 2400MHz$		55		dB

Note 1: Limits are 100% tested at $T_A = +25^\circ C$. Limits over the operating temperature range and relevant supply voltage range are guaranteed by design and characterization.

Note 2: Guaranteed by design and bench characterization.

MAX40079/MAX40087/
MAX40077/MAX40089/
MAX40078

Single/Dual/Quad Ultra-Low
Input Bias Current, Low-Noise Amplifiers

Typical Operating Characteristics

$V_{DD} = +5V$, $V_{SS} = 0V$, $V_{CM} = V_{DD}/2$, $R_L = 10k\Omega$ to $V_{DD}/2$, $C_L = 10pF$ to GND, $T_A = +25^\circ C$, unless otherwise noted. ($T_A = +25^\circ C$, unless otherwise noted.)

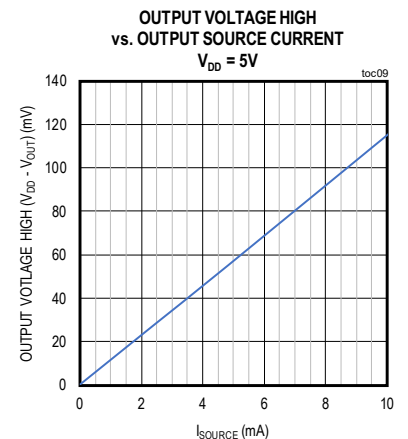
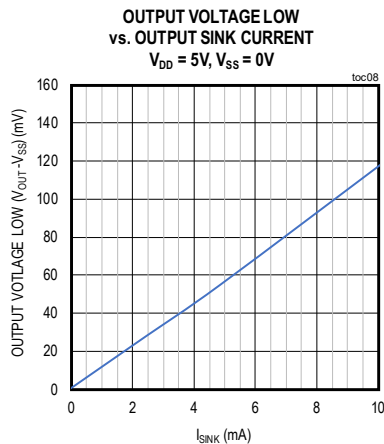
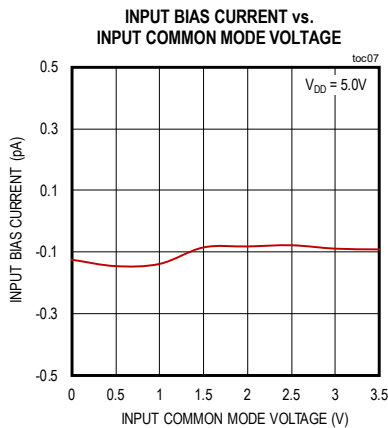
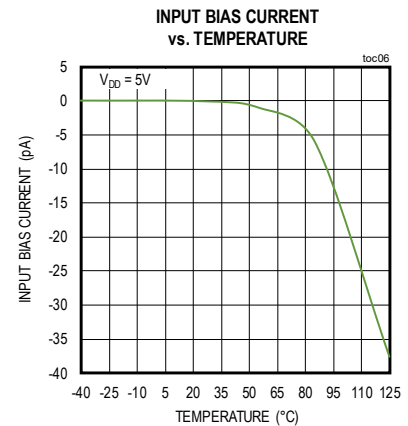
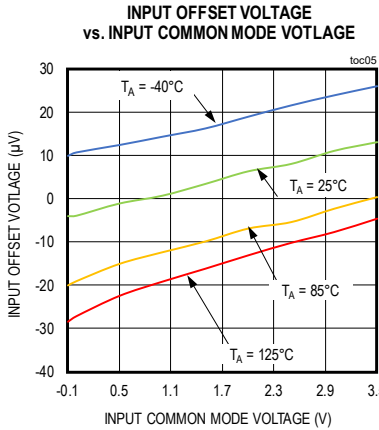
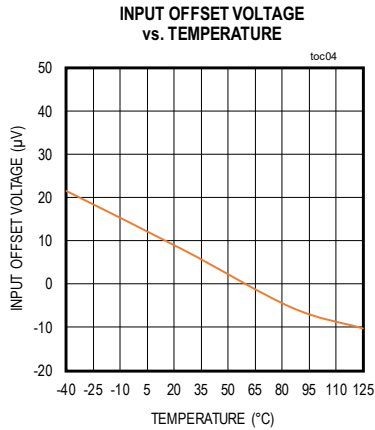
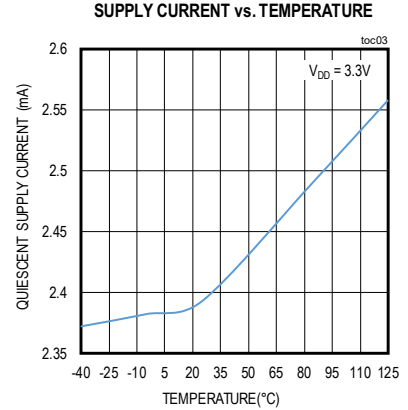
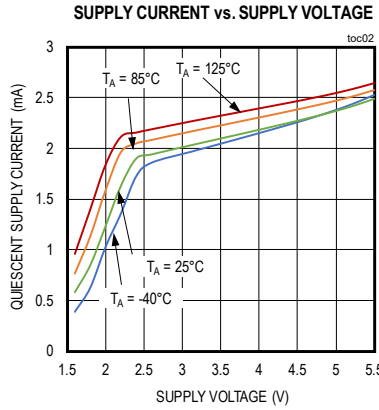
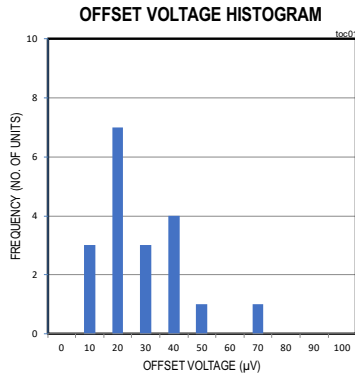

MAX40079/MAX40087/
MAX40077/MAX40089/
MAX40078

Single/Dual/Quad Ultra-Low
Input Bias Current, Low-Noise Amplifiers

Typical Operating Characteristics (continued)

$V_{DD} = +5V$, $V_{SS} = 0V$, $V_{CM} = V_{DD}/2$, $R_L = 10k\Omega$ to $V_{DD}/2$, $C_L = 10pF$ to GND, $T_A = +25^\circ C$, unless otherwise noted. ($T_A = +25^\circ C$, unless otherwise noted.)

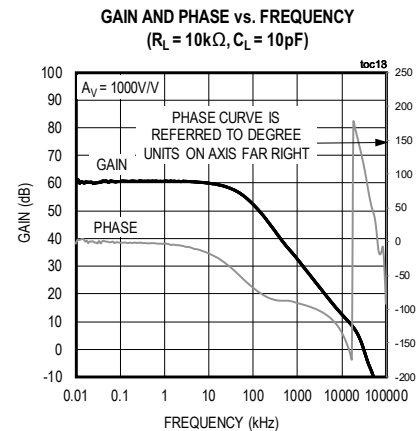
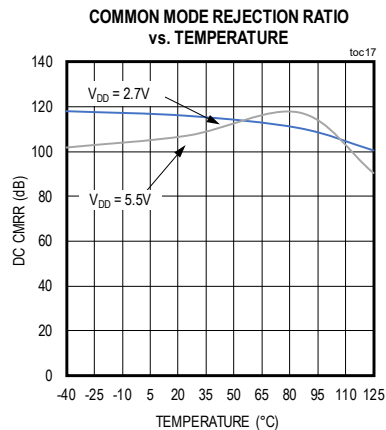
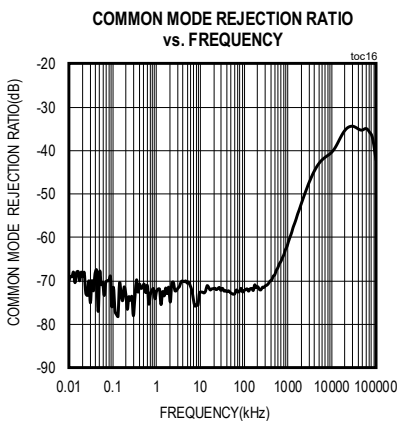
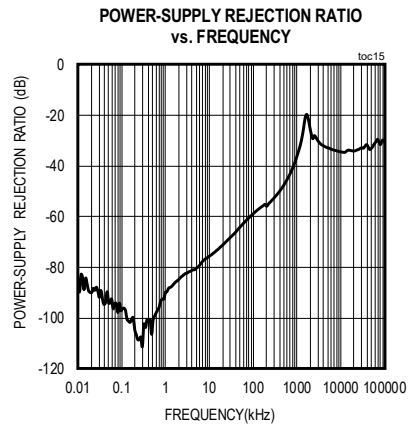
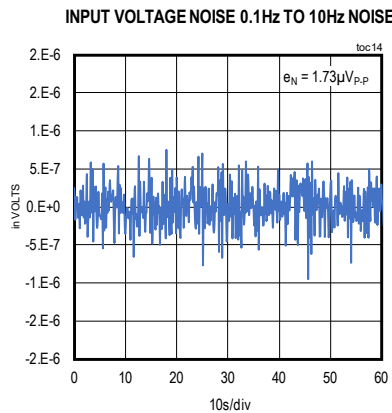
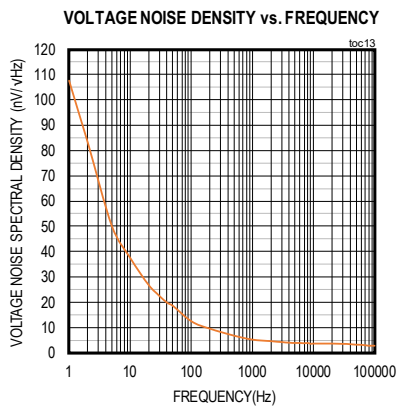
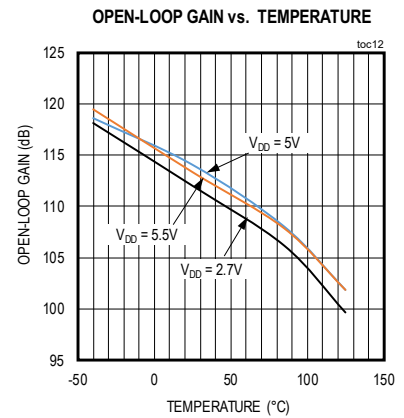
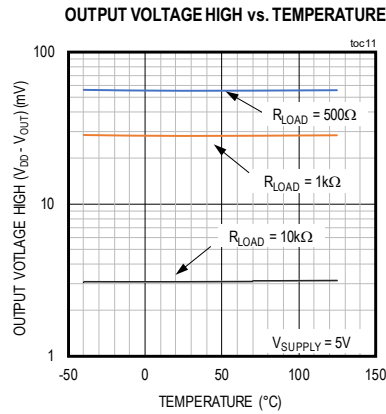
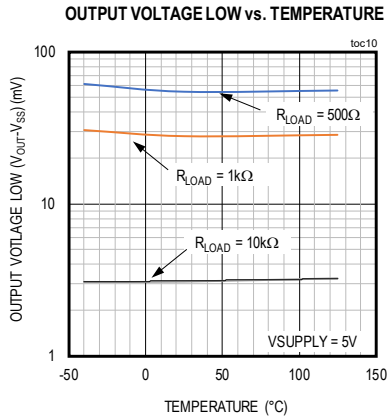

MAX40079/MAX40087/
MAX40077/MAX40089/
MAX40078

Single/Dual/Quad Ultra-Low
Input Bias Current, Low-Noise Amplifiers

Typical Operating Characteristics (continued)

$V_{DD} = +5V$, $V_{SS} = 0V$, $V_{CM} = V_{DD}/2$, $R_L = 10k\Omega$ to $V_{DD}/2$, $C_L = 10pF$ to GND, $T_A = +25^\circ C$, unless otherwise noted. ($T_A = +25^\circ C$, unless otherwise noted.)

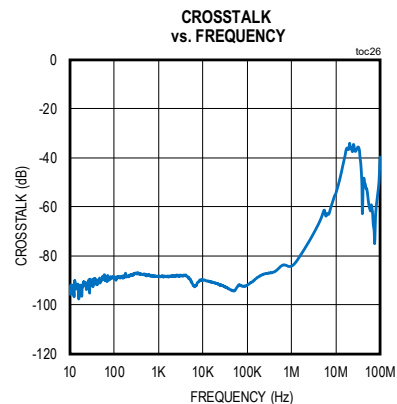
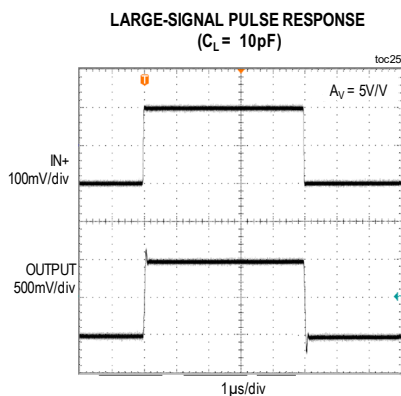
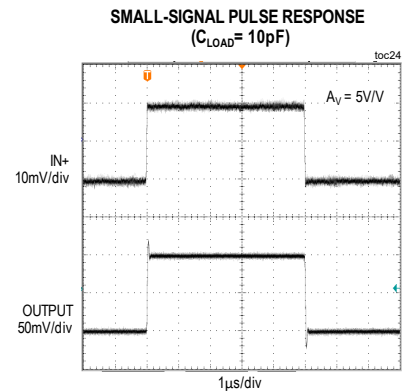
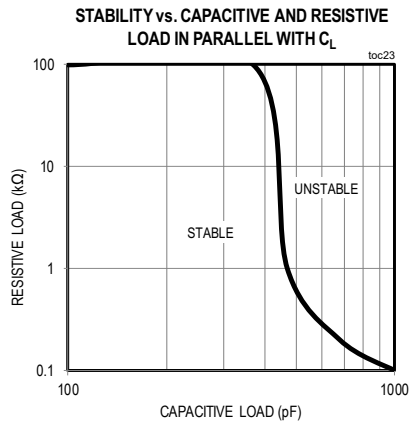
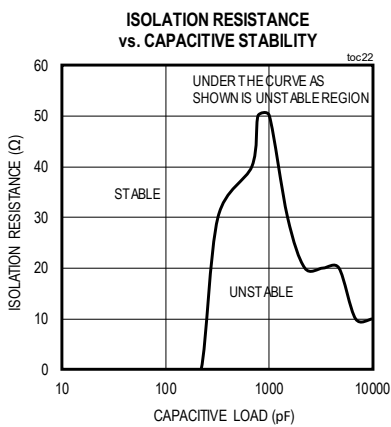
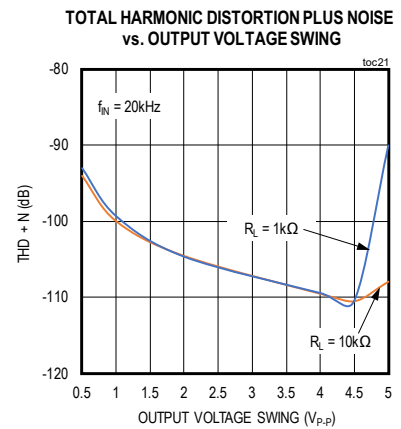
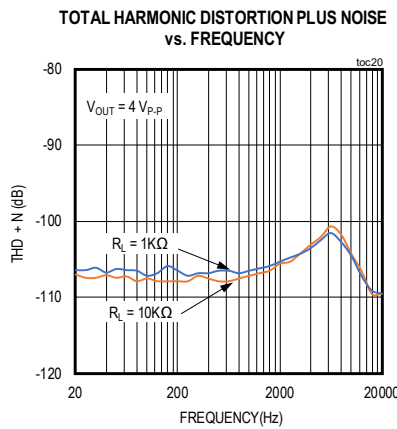
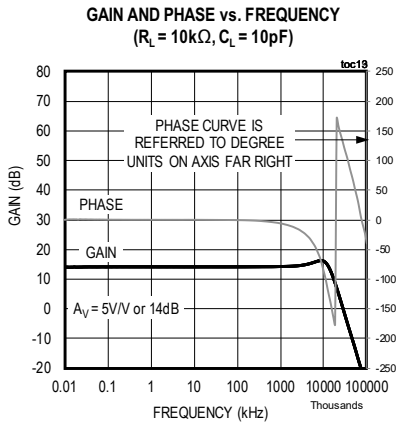

MAX40079/MAX40087/
MAX40077/MAX40089/
MAX40078

Single/Dual/Quad Ultra-Low
Input Bias Current, Low-Noise Amplifiers

Pin Configurations

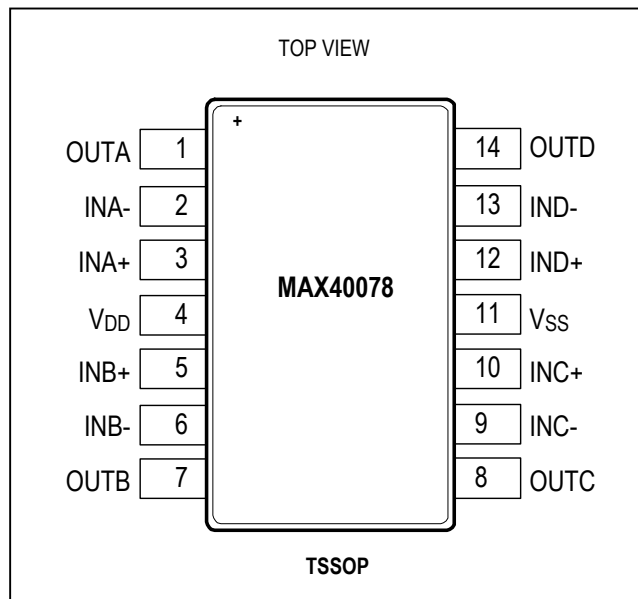
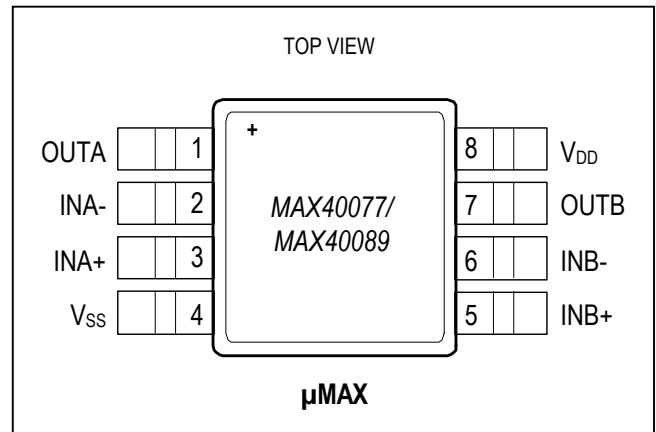
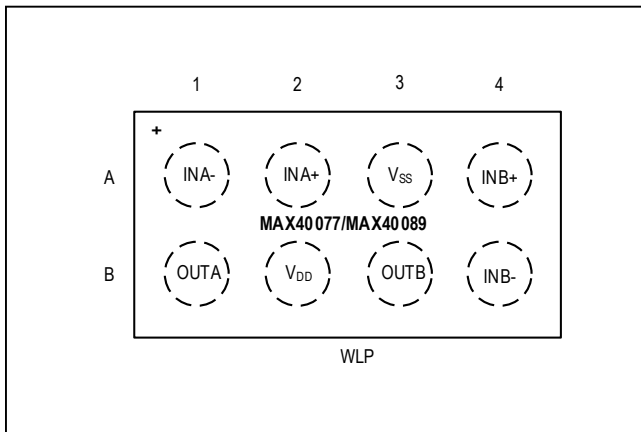
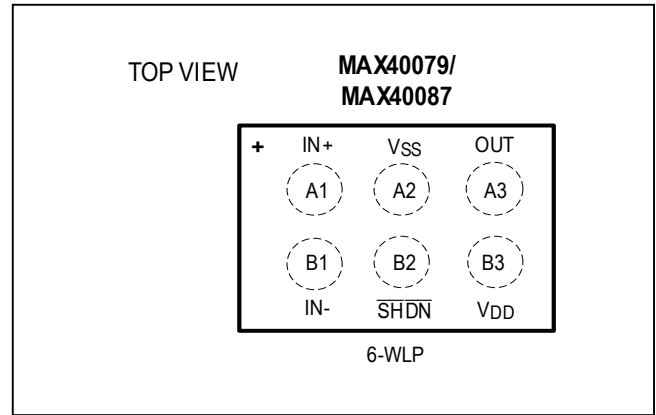
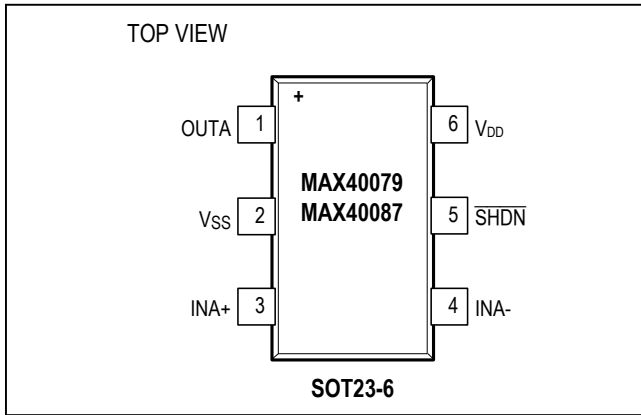

MAX40079/MAX40087/
 MAX40077/MAX40089/
 MAX40078

Single/Dual/Quad Ultra-Low
 Input Bias Current, Low-Noise Amplifiers

Pin Description

PIN					NAME	FUNCTION
SOT23-6	6-WLP	8-WLP	8-MMAX	14-TSSOP		
1	A3	B1	1	1	OUTA	Output, Channel A
2	A2	A3	4	11	V _{SS}	Negative Power Supply Input. Connect V _{SS} to 0V in single-supply application.
3	A1	A2	3	3	INA+	Non-Inverting Input, Channel A
4	B1	A1	2	2	INA-	Inverting Input, Channel A
5	B2	—	—	—	$\overline{\text{SHDN}}$	Shutdown. Pull high for normal operation and low for shutdown
6	B3	B2	8	4	V _{DD}	Positive Power Supply Voltage Input
—	—	A4	5	5	INB+	Noninverting Input, Channel B
—	—	B4	6	6	INB-	Inverting Input, Channel B
—	—	B3	7	7	OUTB	Output, Channel B
—	—	—	—	10	INC+	Noninverting Input, Channel C
—	—	—	—	9	INC-	Inverting Input, Channel C
—	—	—	—	8	OUTC	Output, Channel C
—	—	—	—	12	IND+	Noninverting Input, Channel D
—	—	—	—	13	IND-	Inverting Input, Channel D
—	—	—	—	14	OUTD	Output, Channel D

Functional Diagram

Internal ESD Protection

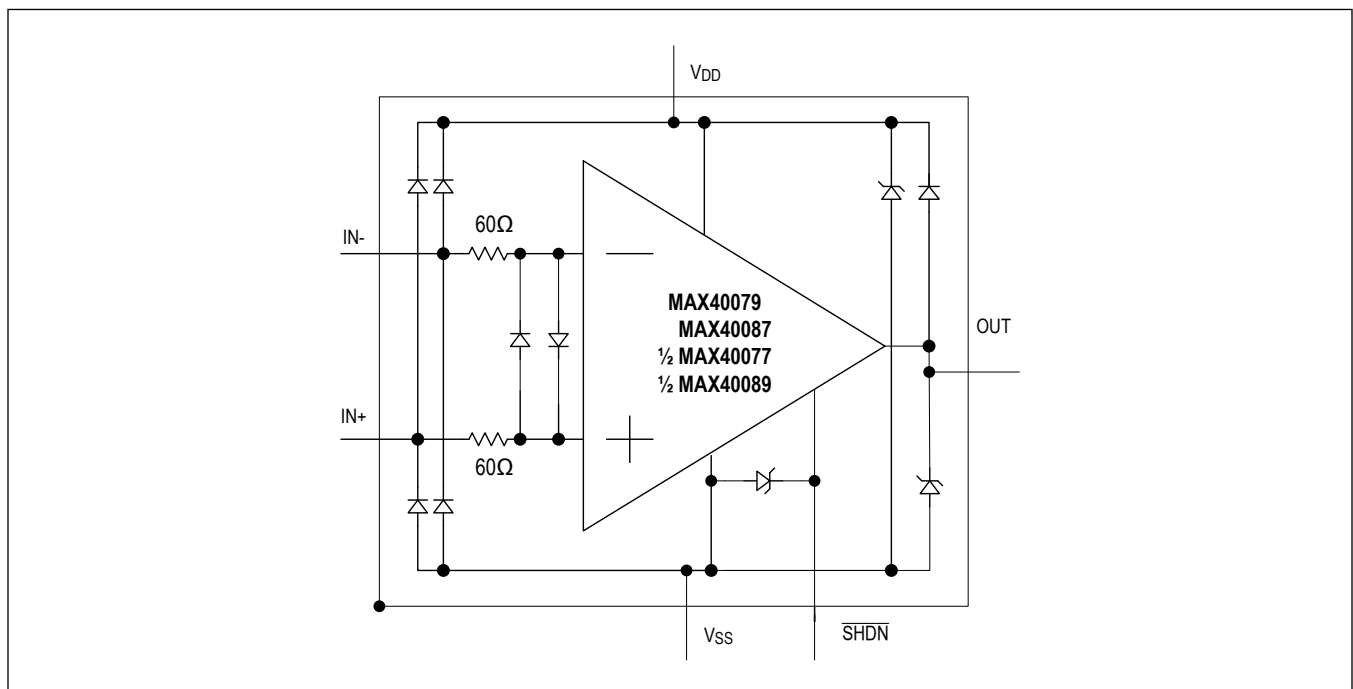

MAX40079/MAX40087/ MAX40077/MAX40089/ MAX40078

Single/Dual/Quad Ultra-Low Input Bias Current, Low-Noise Amplifiers

Detailed Description

The MAX40079/MAX40087/MAX40077/MAX40089/MAX40078 single/dual/quad channel operational amplifiers feature ultra-low noise and distortion. Their low distortion and low noise make them ideal for use as pre-amplifiers in wide dynamic range applications, such as 16-bit analog-to-digital converters. Their high input impedance and low noise are also useful for signal conditioning of high-impedance sources, such as piezoelectric transducers.

These devices have true rail-to-rail output operation, drive output resistive loads as low as 1k Ω while maintaining DC accuracy and can drive capacitive loads up to 200pF without any oscillation. The input common-mode voltage range extends from 0.2V below V_{SS} to ($V_{DD} - 1.5V$). The push-pull output stage maintains excellent DC characteristics, while delivering up to ± 20 mA of source/sink output current.

The MAX40079/MAX40079/MAX40078 are single/dual/quad respectively that are unity-gain stable, while the MAX40087/MAX40089, single/dual respectively are decompensated version having higher slew rate and are stable for Gain $\geq 5V/V$. The MAX40079/MAX40087 single channel op amps feature a low-power shutdown mode, which reduces the supply current to 0.1 μA and places amplifiers outputs into a high impedance state.

Low Noise

The amplifiers input-referred voltage noise density is dominated by flicker noise (also known as 1/f noise) at lower frequencies and by thermal noise at higher frequencies. Overall thermal noise contribution is affected by the parallel combination of resistive feedback network ($R_F || R_G$) depicted in [Figure 1](#). These resistors should be reduced in cases where system bandwidth is large and thermal noise is dominant. Noise contribution factor can be reduced with increased gain settings.

For example, the input noise voltage density (e_N) of the circuit with $R_F = 100k\Omega$, $R_G = 10k\Omega$ with Gain = 11V/V non-inverting configuration is $e_N = 12nV/\sqrt{Hz}$.

e_N can be reduced to 6nV/ \sqrt{Hz} by choosing $R_F = 10k\Omega$, smaller $R_G = 1k\Omega$ compared to 10k Ω with still same Gain = 11V/V but at the expense of higher current consumption and higher distortion. Noise of this circuit is effectively reduced due to smaller value of R_G that dominates system noise.

Having a Gain of 101V/V with $R_F = 100k\Omega$, $R_G = 1k\Omega$, input referred voltage noise density is still a low 6nV/ \sqrt{Hz} as the noise dominating resistor R_G remained the same.

Low Distortion

Many factors can affect the noise and distortion performance of the amplifier based on the design choices made. The following guidelines offer valuable information on the impact of design choices on total harmonic distortion (THD). Choosing correct feedback and gain resistor values for a particular application can be a very important factor in reducing THD. In general, the smaller the closed-loop gain, the smaller the THD generated, especially when driving heavy resistive loads (in other words, smaller resistive load with higher output current). Operating the device near or above the full-power bandwidth significantly degrades distortion.

Referencing the load to either supply also improves the amplifier distortion performance, because only one of the MOSFETs of the push-pull output stage drives the output. Referencing the load to mid-supply increases the amplifier distortion for a given load and feedback setting (See the *Total Harmonic Distortion vs. Frequency* graph in the [Typical Operating Characteristics](#)).

For gains $\geq 5V/V$, the de-compensated MAX40087/MAX40089 deliver the best distortion performance as they have a higher slew rate and provide a higher amount of loop gain for a given closed-loop gain setting. Capacitive loads below 100pF do not significantly affect distortion results. Distortion performance is relatively constant over supply voltages.

Input Protection

As per [Functional Diagram](#), when voltage on either of the input pins goes up or below V_{DD} or V_{SS} by more than a diode voltage drop, ESD diodes begin to turn-on/forward bias and large amount of current flow through these diodes. If op amp inputs in certain applications are subject to these over-voltage conditions, insert a series current limiting 50 ohm resistors on either inputs. However, note that DC precision of the system be affected due to these series resistors and also thermal noise of these resistors need to be considered while making noise analysis of the entire circuit.

An input differential protection scheme is used (refer to [Functional Diagram](#)) that protect the device if there is a large differential voltage applied across input pins. A series of 60 Ω resistors are used in conjunction with a pair of back to back diodes that turn on in an event of differential voltage beyond a diode drop. A pair of 60 Ω resistors limit current flowing through these diodes so that the current is limited below abs max rating of $\pm 20mA$.

MAX40079/MAX40087/
MAX40077/MAX40089/
MAX40078

Single/Dual/Quad Ultra-Low
Input Bias Current, Low-Noise Amplifiers

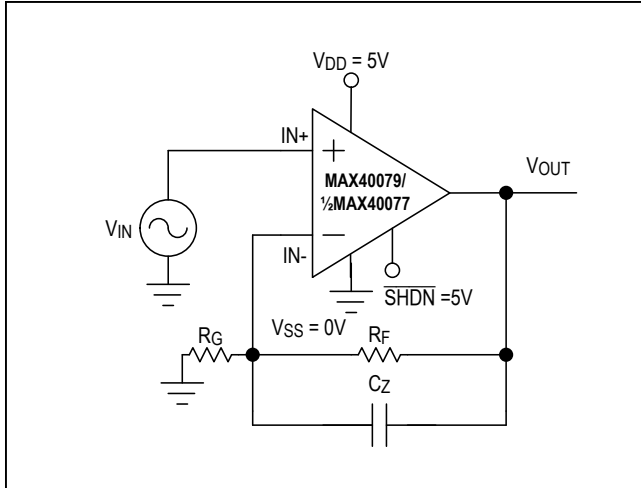

Figure 1. Adding Feed-Forward Compensation

Since there is a differential protection scheme used in these family of op amps, these amplifiers cannot be used as comparators in open loop, which is often a possibility on an unused channel of op amp.

Using a Feed-Forward Compensation Capacitor, C_Z

The amplifier's input capacitance is 7pF and if the resistance seen by the inverting input is large (Figure 1) as a result of feedback network, this resistance and capacitance combination can introduce a pole within the amplifier's bandwidth resulting in reduced phase margin. Compensate the reduced phase margin by introducing a feed-forward capacitor (C_Z) between the inverting input and the output (shown in Figure 1). This effectively cancels the pole from the inverting input of the amplifier. Choose the value of C_Z as follows:

$$C_Z = 10 \times (R_F/R_G) \text{ [pF]}$$

In the unity-gain stable: MAX40079/MAX40077/MAX40078, the use of correct value C_Z is most important for closed loop non-inverting gain $A_V = +2V/V$, and inverting gain $A_V = -1V/V$.

In the de-compensated MAX40087/MAX40089, C_Z is most important for closed loop gain $A_V = +10V/V$.

Using a slightly smaller C_Z than suggested by the formula above achieves a higher bandwidth at the expense of reduced phase and gain margin. As a general guideline, consider using C_Z for cases where $R_G || R_F$ is greater than 20k Ω (for MAX40079/MAX40077/MAX40078) and greater than 5k Ω (for MAX40087/MAX40089).

Applications Information

The MAX40079/MAX40087/MAX40077/MAX40089/MAX40078 family of op amps combine good driving capability that can also support ground/low-side sensing input and rail-to-rail output operation. With their low distortion and low noise, they are ideal for use in ADC buffers, DAC output buffers, medical instrumentation systems and other noise-sensitive applications.

However, there are two main application areas where these ultra-low input bias current op amps find place and they are to measure high impedance measurements. High Impedance measurements can be interfacing either Current output sensors or voltage output sensors that would need very high output resistance to be interfaced with. These op amps offer just that as the input impedance of these amplifiers is in the range of 1000G Ω .

Voltage output sensors readout can be accomplished with unity gain buffer configuration and current output sensors like photo-diodes current read out can be accomplished in transimpedance amplifier configuration discussed later in this data sheet.

Ground-Sensing and Rail-to-Rail Outputs

The common-mode input range of these devices extends below ground over temperature that offers excellent common mode rejection and can be used in low side current sensing applications. These devices are guaranteed not to undergo phase reversal when the input is overdriven over input common mode voltage range as shown in Figure 2.

Figure 3 showcases the true rail-to-rail output operation of the amplifier, configured with $A_V = 5V/V$. The output swings to within 8mV of the supplies with a 10k Ω load, making the devices ideal in low-supply voltage applications.

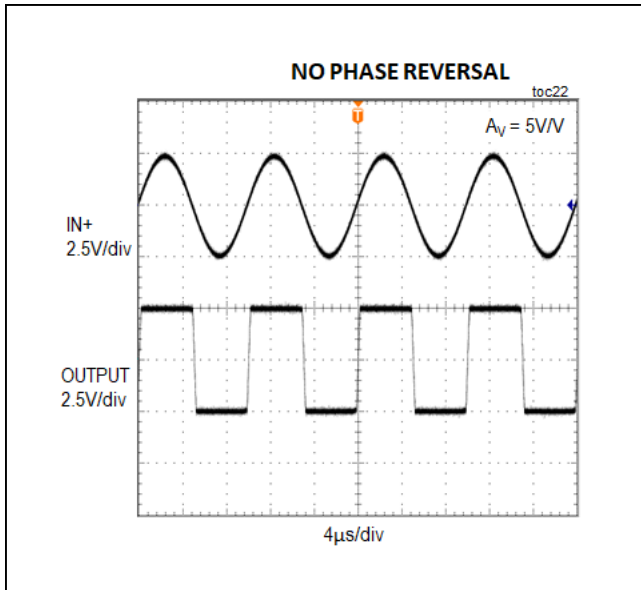

Figure 2. Scope Plot Showing Overdriven Input with No Phase Reversal

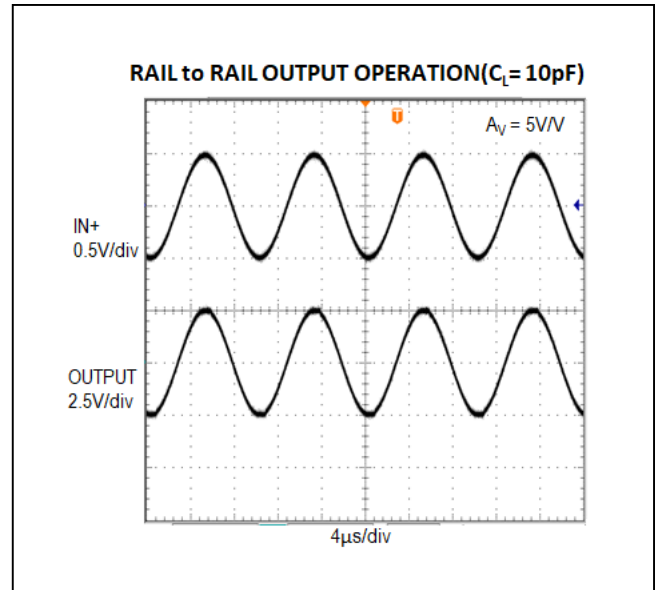

Figure 3. Rail-to-Rail Output Operation with 10kΩ

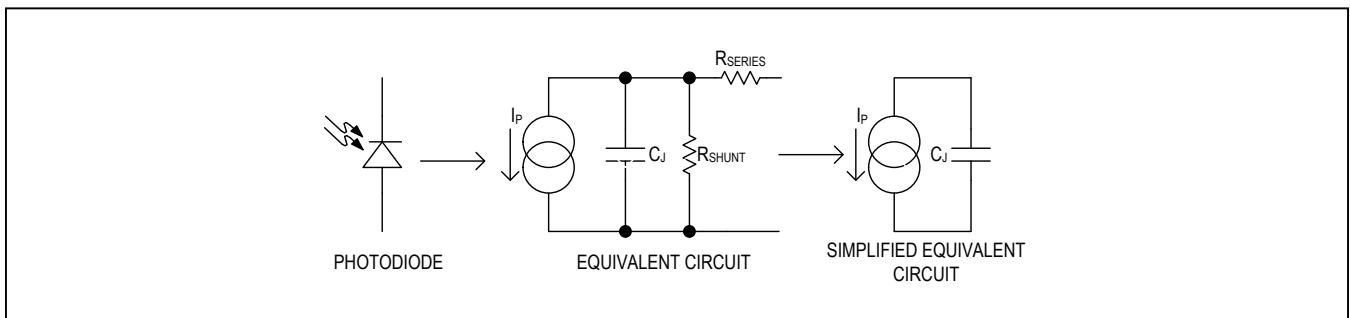

Figure 4. Photodiode Equivalent Circuit Showing Parasitics

Typical Application Circuit

Extremely Low-Leakage Op Amp (~50fA) Used as Transimpedance Amplifier

The ultra-low input bias current and low noise profile makes it an excellent choice for high impedance applications. It should be noted that unity gain stable is not a requirement for TIA applications. MAX40087/MAX40089 with increased GBW of 42MHz (min $A_v \geq 5V/V$) may also be an option.

Figure 6 shows a transimpedance amplifier using MAX40077 suited for low to moderate TIA applications in

photo-voltaic mode with buffered reference. This enables negligible reverse-voltage across the photodiode which ensures little to no dark current. A typical bias point of 100mV–200mV may be used to ensure the output of amplifier to be in linear range. Because of the nature of photo-diode in photo-voltaic modes, the input capacitance is more as compared to photo-conductive mode. Therefore, this mode is chosen for slower to moderate photo-diode current applications but this methodology provides high linearity, better accuracy and low noise performance.

MAX40079/MAX40087/
MAX40077/MAX40089/
MAX40078

Single/Dual/Quad Ultra-Low
Input Bias Current, Low-Noise Amplifiers

Photodiode Equivalent Circuit (Figure 4):

I_P is current flowing through photodiode proportional to intensity of light on photodiode sensor

C_J is the junction input capacitance of the photodiode

R_{SHUNT} is the internal shunt resistance of the photodiode

R_{SERIES} is the internal series resistance of the photodiode

where $V_{OUT} = I_P \times R_1$

where same equation still applies $V_{OUT} = I_P \times R_1$

The input capacitance of the diode can destabilize the amplifier when choosing R_1 in such a way that $1/(2 \times \pi \times R_1 \times C_J) < GBW$ of the op amp. A feedback capacitance

is required to add a zero to compensate for the phase shift. To learn more about Trans-impedance amplifier stabilization, please refer to the app note: [AN5129: Stabilize your Transimpedance Amplifier](#).

For a critically damped system the $f_{-3dB} =$

$$\sqrt{(GBW)/(2 \times \pi \times R_1 \times (C_1 + C_J))}$$

and the value of C_1

$$= \sqrt{(C_J/2 \times \pi \times R_1 \times GBW)}$$

When using MAX40087 de-compensated Op-Amp, care must be taken that the noise gain $(1 + C_J/C_1)$ at higher frequencies is higher than gain of $5V/V$ in order to stabilize the TIA.

Noise Consideration: choosing lower R_1 will provide lower transimpedance and higher BW, but this may result in higher noise as the signal reduces by a factor of R_1 and noise reduces by factor of $\sqrt{R_1}$.

The noise contribution of R_1 can be reduced by increasing the C_1 value, but this lowers the bandwidth. A careful trade-off must be done to improve the signal-to-noise ratio (SNR).

Output Buffering of an Un-Buffered DAC:

The [Figure 7](#) shows the single MAX40079 configured as an output buffer for the MAX5541 16-bit DAC. Because the MAX5541 has an unbuffered voltage output, the input bias current of the op amp used must be less than $6nA$ to maintain 16-bit accuracy. This family of amplifiers have an input bias current of only $160pA$ (max) over temperature, virtually eliminating this as a source of error. In addition, the MAX40079 has excellent open loop gain and common-mode rejection, making this an excellent output buffer amplifier.

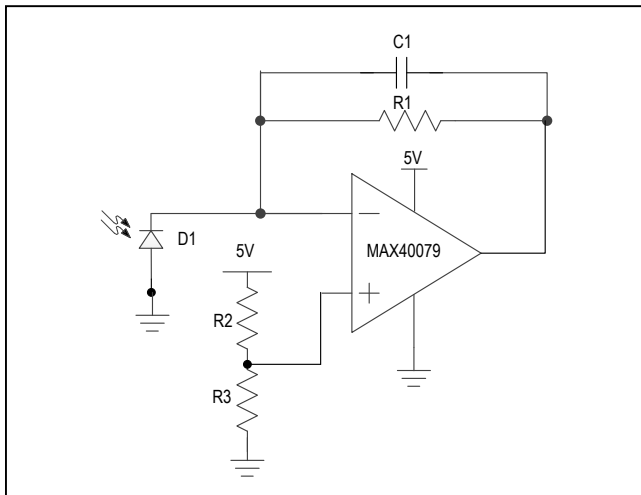

Figure 5. Single-Supply Transimpedance Amplifier Configuration with Single-Channel Op Amp

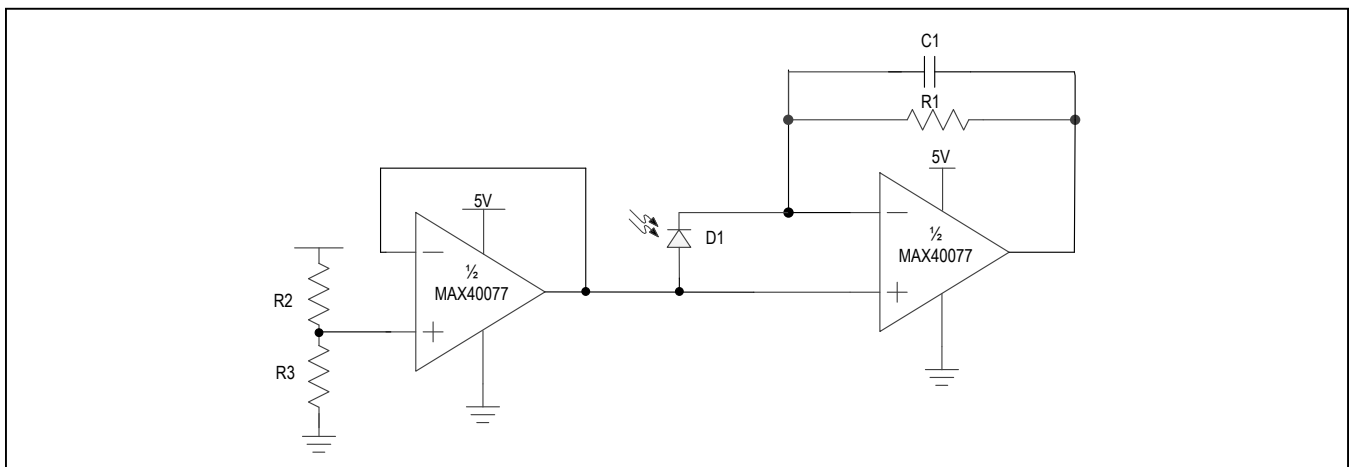

Figure 6. Single-Supply Transimpedance Amplifier Configuration with Dual-Channel Op Amp

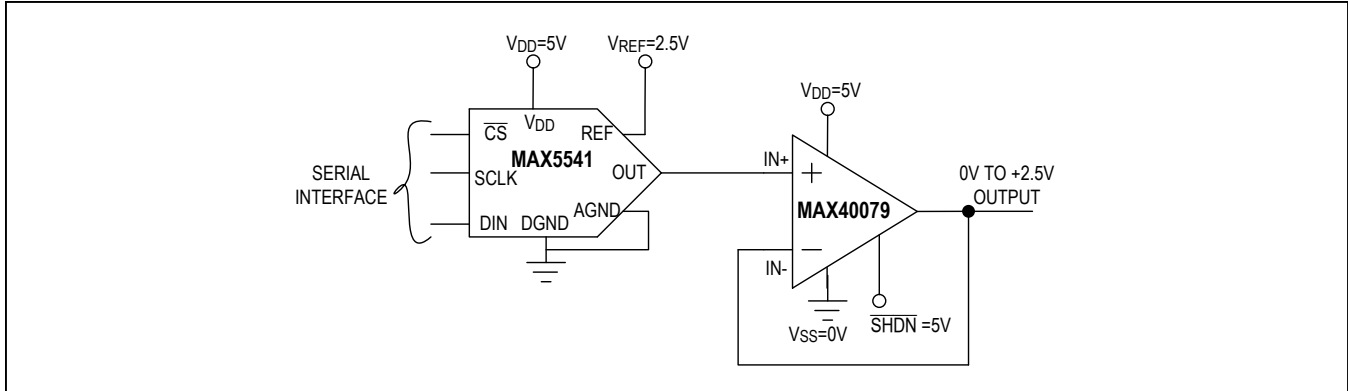

Figure 7. DAC Output Buffering with Op Amp

Capacitive Load Stability

The MAX40079 family of op amps drive up to 50pF in all configurations without any oscillation. Driving higher capacitive loads than 50pF might lead to oscillation in certain configurations due to reduction in phase margin and it can be seen as overshoot and undershoot with a step response on oscilloscope. If the application demands for the op amp to drive more than 50pF capacitive loads, it is recommended to add a series isolation resistor of 10-50Ω on the op amp output before capacitive load. Size of this resistor depends on the amount of capacitive load op amp is driving. Please refer to *Isolation Resistance vs. Capacitive Stability* graph in [Typical Operating Characteristics](#) for more information on resistance sizing.

This series isolation resistance is very useful in unity gain buffer configuration when full scale signal output swing is used as the unity gain configuration is the worst case for stability while driving capacitive loads.

Flux and Solder Contaminant Removal

Upon soldering process of the op amp on the PCB, remains of solder flux is a major performance degrading factor in measuring ultra-low input bias currents in the order of 50fA. Solvents like isopropyl alcohol (IPA) are effective in cleaning up solder flux contaminants. Upon clearly rubbing off the solder flux areas with IPA, ultrasonic

cleaning in bath is highly recommended. Once the bath is completed, it can be dried up either at room temperature for several hours or placing the cleaned up PCB in an oven at elevated temperature for quick usage.

Power Supplies and Layout

The MAX40079/MAX40087/MAX40077/MAX40089/MAX40078 op amps operate from a single +2.7V to +5.5V power supply or from dual supplies of ±1.35V to ±2.75V. For single-supply operation, bypass the V_{DD} power supply pin with a 0.1μF ceramic capacitor placed close to the V_{DD} pin. If operating from dual supplies, bypass both V_{DD} and V_{SS} supply pins with 0.1μF ceramic capacitor to ground. If additional decoupling is needed add another 4.7μF or 10μF where supply voltage is applied on PCB.

Good layout improves performance by decreasing the amount of stray capacitance and noise at the op amp inputs and output. To decrease stray capacitance, minimize PC board trace lengths and resistor leads, and place external components close to the op amp's pins.

Guard rings and Shielding is highly recommended to guard the high impedance input traces against input leakage current. Refer to MAX40077 EV kit data sheet for more information on this. This is accomplished using a Triax connector and driving it's guard to the same potential as the signal on high impedance input.

MAX40079/MAX40087/
MAX40077/MAX40089/
MAX40078

Single/Dual/Quad Ultra-Low
Input Bias Current, Low-Noise Amplifiers

Ordering Information

PART NUMBER	NUMBER OF CHANNELS	TEMP RANGE	PIN-PACKAGE	[STABLE GAIN V/V]	[GAIN BANDWIDTH PRODUCT IN MHZ]
MAX40079ANT+T	Single	-40°C to +125°C	6-WLP	1	10
MAX40079AUT+T	Single	-40°C to +125°C	6-SOT23	1	10
MAX40087ANT+T	Single	-40°C to +125°C	6-WLP	5	42
MAX40087AUT+T	Single	-40°C to +125°C	6-SOT23	5	42
MAX40077ANA+T	Dual	-40°C to +125°C	8-WLP	1	10
MAX40077AUA+T	Dual	-40°C to +125°C	μMAX-8	1	10
MAX40089ANA+T	Dual	-40°C to +125°C	8-WLP	5	42
MAX40089AUA+T	Dual	-40°C to +125°C	μMAX-8	5	42
MAX40078AUD+T	Quad	-40°C to +125°C	14 TSSOP	1	10

+Denotes a lead(Pb)-free/RoHS-compliant package.

T = Denotes tape-and-reel.

MAX40079/MAX40087/
MAX40077/MAX40089/
MAX40078

Single/Dual/Quad Ultra-Low
Input Bias Current, Low-Noise Amplifiers

Revision History

REVISION NUMBER	REVISION DATE	DESCRIPTION	PAGES CHANGED
0	1/18	Initial release	—
1	3/18	Updated <i>Electrical Characteristics</i> and <i>Ordering Information</i> tables	3, 4, 6, 8, 16
2	5/18	Updated future product status of MAX40078AUD+T in <i>Ordering Information</i> table	16
3	7/18	Updated <i>General Description</i> section and <i>Ordering Information</i> table	16
4	3/19	Updated <i>Ordering Information</i>	16
5	7/19	Updated <i>Pin Configuration</i> diagram and <i>Pin Description</i> table	9, 10
6	11/19	Updated <i>Pin Configuration</i> , <i>Pin Description</i> , and <i>Ordering Information</i>	9, 10, 16
7	1/20	Updated <i>Pin Configuration</i> and <i>Ordering Information</i>	9, 16
8	4/20	Updated <i>Benefits and Features</i> , added package outline drawing	1, 3

For pricing, delivery, and ordering information, please visit Maxim Integrated's online storefront at <https://www.maximintegrated.com/en/storefront/storefront.html>.

Maxim Integrated cannot assume responsibility for use of any circuitry other than circuitry entirely embodied in a Maxim Integrated product. No circuit patent licenses are implied. Maxim Integrated reserves the right to change the circuitry and specifications without notice at any time. The parametric values (min and max limits) shown in the *Electrical Characteristics* table are guaranteed. Other parametric values quoted in this data sheet are provided for guidance.

X-ON Electronics

Largest Supplier of Electrical and Electronic Components

Click to view similar products for [Operational Amplifiers - Op Amps](#) category:

Click to view products by [Maxim](#) manufacturer:

Other Similar products are found below :

[LM258AYDT](#) [LM358SNG](#) [430227FB](#) [UPC824G2-A](#) [LT1678IS8](#) [042225DB](#) [058184EB](#) [UPC259G2-A](#) [NTE925](#) [AZV358MTR-G1](#)
[AP4310AUMTR-AG1](#) [HA1630D02MMEL-E](#) [HA1630S01LPEL-E](#) [SCY33178DR2G](#) [NJU77806F3-TE1](#) [NCV20034DR2G](#) [LM324EDR2G](#)
[LM2902EDR2G](#) [NTE7155](#) [NTE778S](#) [NTE871](#) [NTE924](#) [NTE937](#) [MCP6V17T-E/MNY](#) [MCP6V19-E/ST](#) [MCP6V36UT-E/LTY](#)
[MXD8011HF](#) [MCP6V17T-E/MS](#) [SCY6358ADR2G](#) [LTC2065HUD#PBF](#) [NJM2904CRB1-TE1](#) [2SD965T-R](#) [RS6332P XK](#) [BDM8551](#)
[BDM321](#) [MD1324](#) [COS8052SR](#) [COS8552SR](#) [COS8554SR](#) [COS2177SR](#) [COS2353SR](#) [COS724TR](#) [ASOPD4580S-R](#) [RS321BKXF](#)
[ADA4097-1HUIZ-RL7](#) [NCV4333DTBR2G](#) [EL5420CRZ-T7A](#) [AS324MTR-E1](#) [AS358MMTR-G1](#) [MCP6491T-ELTY](#)