

Click [here](#) for production status of specific part numbers.

MAX41461/MAX41462

300MHz–960MHz ASK Transmitter with I²C Interface

General Description

The MAX41461/MAX41462 is a UHF sub-GHz ISM/SRD transmitter is designed to transmit On-Off Keying (OOK) or Amplitude-Shift Keying (ASK) data in the 286MHz to 960MHz frequency range. It integrates a fractional phase-locked-loop (PLL), so a single, low-cost crystal can be used to generate commonly used world-wide sub-GHz frequencies. The fast response time of the PLL allows for frequency-hopping spread spectrum protocols for increased range and security. The chip also features preset modes with pin-selectable frequencies so that only one wire is required for external microcontroller interface. The only frequency-dependent components required are for the external antenna matching network. Optionally, the device can be put into programmable mode and programmed using an I²C interface. The crystal-based architecture of the MAX41461/MAX41462 eliminates many of the common problems with SAW-based transmitters by providing greater modulation depth, faster frequency settling, higher tolerance of the transmit frequency, and reduced temperature dependence. A clock-out signal at 800kHz is also provided.

The MAX41461/MAX41462 provides output power up to +13dBm into a 50Ω load while drawing < 8mA (Manchester coded). The output load can be adjusted to increase power up to +16dBm, and a PA boost mode can be enabled at frequencies above 850MHz to compensate for losses. The PA output power can also be controlled using programmable register settings in I²C mode.

The MAX41461/MAX41462 also features single-supply operation from +1.8V to +3.6V. The device has an auto-shutdown feature to extend battery life and a fast oscillator wake-up with data activity detection.

The MAX41461/MAX41462 is available in a 10-pin μMAX package and is specified over the -40°C to +105°C extended temperature range. The MAX41461/MAX41462 has an ESD rating of 2.5kV HBM.

Applications

- Building Automation and Security
- Wireless Sensors and Alarms
- Remote and Passive Keyless Entry (RKE/PKE)
- Tire Pressure Monitoring Systems (TPMS)
- Automatic Meter Reading (AMR)
- Garage Door Openers (GDO)
- Radio Control Toys
- Internet of Things (IoT)

Benefits and Features

- Low Implementation Cost
 - Bits-to-RF Single Wire Operation
 - Low Bill-of-Materials (BOM)
 - Uses Single, Low-Cost, 16MHz Crystal
 - Small 3mm x 3mm μMAX-10 Package
- Increased Range, Data Rates, and Security
 - Up to +16dBm PA Output Power
 - Fast Frequency Switching for FHSS/DSSS
 - Fast-On Oscillator: < 250μs Startup Time
 - Up to 200kbps NRZ Data Rate
- Extend Battery Life with Low Supply Current
 - < 8mA ASK Manchester Coded
 - Selectable Standby and Shutdown Modes
 - Auto Shutdown at < 20nA (typ) Current
- Ease of Use
 - Pin Selectable 300MHz–928MHz Frequencies
 - Pin Compatible ASK and FSK Versions
 - +1.8V to +3.6V Single-Supply Operation
 - Fully Programmable with 400kHz/1MHz I²C Interface

Ordering Information appears at end of data sheet.

Simplified Block Diagram

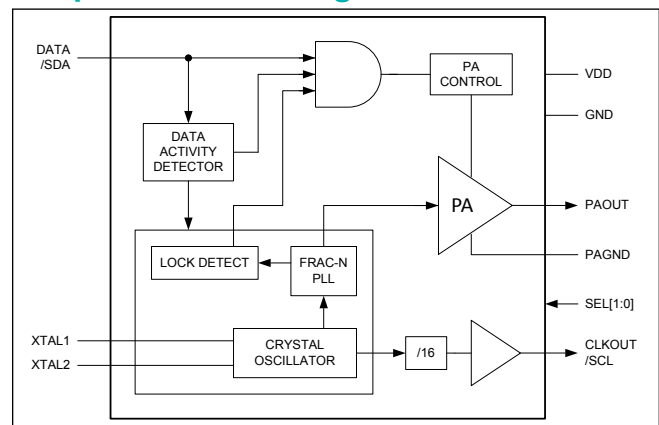

Absolute Maximum Ratings

V _{DD} to GND.....	-0.3V to +4V	Junction Temperature	+150°C
All Others Pins to GND.....	-0.3V to (V _{DD} + 0.3)V	Storage Temperature Range	-60°C to +150°C
Continuous Power Dissipation (T _A = +70°C, derate 5.6mW/°C above +70°C)	444.4mW	Lead Temperature (reflow)	+300°C
Operating Temperature Range	-40°C to +105°C	Soldering Temperature (reflow)	+260°C

Stresses beyond those listed under "Absolute Maximum Ratings" may cause permanent damage to the device. These are stress ratings only, and functional operation of the device at these or any other conditions beyond those indicated in the operational sections of the specifications is not implied. Exposure to absolute maximum rating conditions for extended periods may affect device reliability.

Package Information

10 μMAX (similar to 10 TSSOP)

Package Code	U10+2
Outline Number	21-0061
Land Pattern Number	90-0330
Thermal Resistance, Single-Layer Board:	
Junction-to-Ambient (θ _{JA})	180°C/W
Junction-to-Case Thermal Resistance (θ _{JC})	36°C/W
Thermal Resistance, Four-Layer Board:	
Junction-to-Ambient (θ _{JA})	113.1°C/W
Junction-to-Case Thermal Resistance (θ _{JC})	36°C/W

For the latest package outline information and land patterns (footprints), go to www.maximintegrated.com/packages. Note that a "+", "#", or "-" in the package code indicates RoHS status only. Package drawings may show a different suffix character, but the drawing pertains to the package regardless of RoHS status.

Package thermal resistances were obtained using the method described in JEDEC specification JESD51-7, using a four-layer board. For detailed information on package thermal considerations, refer to www.maximintegrated.com/thermal-tutorial.

Electrical Characteristics

(*Typical Application Circuit*, all RF inputs and outputs are referenced to 50Ω, V_{DD} = +1.8V to +3.6V, T_A = -40°C to +105°C, P_{OUT} = +13dBm for 300MHz–450MHz or +11dBm for 863MHz–928MHz, PA_BOOST = 0, unless otherwise noted. Typical values are at V_{DD} = +3V, T_A = +25°C, unless otherwise noted. (Note 1))

PARAMETER	SYMBOL	CONDITIONS		MIN	TYP	MAX	UNITS
DC CHARACTERISTICS							
Operating Current	I _{DD}	V _{DATA} at 50% duty cycle (ASK) (Note 3, Note 4)	f _{RF} = 315MHz		7	12	mA
		V _{DATA} at 50% duty cycle (ASK) (Note 3, Note 4)	f _{RF} = 434MHz		8	12	
			f _{RF} = 863MHz–928MHz		10	19	
			f _{RF} = 315MHz, P _{OUT} = 16dBm (Note 5)		24		
			f _{RF} = 434MHz, P _{OUT} = 16dBm (Note 5)		26		
			f _{RF} = 863MHz–928MHz, P _{OUT} = 16dBm, PA_BOOST = 1 (Note 5)		45		
		V _{DATA} at 50% duty cycle (ASK), Low Phase Noise mode (Note 3, Note 4)	f _{RF} = 315MHz		9.5		
			f _{RF} = 434MHz		10.5		
			f _{RF} = 863MHz–928MHz		12.8		
		PA off (Note 2)	f _{RF} = 315MHz		2	3	
			f _{RF} = 434MHz		2	3	
			f _{RF} = 863MHz–928MHz		3	4	
		PA off, Low Phase Noise mode (Note 2)	f _{RF} = 315MHz		4		
f _{RF} = 434MHz			4				
f _{RF} = 863MHz–928MHz			5				
Supply Voltage	V _{DD}	PA_BOOST = 0		1.8	3	3.6	V
		PA_BOOST = 1		1.8	2.7	3.0	
Standby Current	I _{STDBY}	Crystal oscillator on, everything off.	T _A = 25°C		200	500	μA
			T _A = 105°C		250		
Shutdown Current	I _{SHDN}	Everything off	T _A = 25°C		19	100	nA
MODULATION PARAMETERS							
ASK Modulation Depth		Supply current and output power are greatly dependent on board layout and PAOUT match			70		dB
Maximum NRZ Data Rate					200		kbps

Electrical Characteristics (continued)

(*Typical Application Circuit*, all RF inputs and outputs are referenced to 50Ω, V_{DD} = +1.8V to +3.6V, T_A = -40°C to +105°C, P_{OUT} = +13dBm for 300MHz–450MHz or +11dBm for 863MHz–928MHz, PA_BOOST = 0, unless otherwise noted. Typical values are at V_{DD} = +3V, T_A = +25°C, unless otherwise noted. (Note 1))

PARAMETER	SYMBOL	CONDITIONS	MIN	TYP	MAX	UNITS	
POWER AMPLIFIER							
Output Power	P _{OUT}	f _{RF} = 300MHz–450MHz (Note 4)		13		dBm	
		f _{RF} = 300MHz–450MHz (Note 4, Note 5)		17			
		f _{RF} = 863MHz–928MHz (Note 4)		11			
		f _{RF} = 863MHz–928MHz (Note 4, Note 5), PA_BOOST = 1		16			
Maximum Carrier Harmonics		PA_BOOST = 0. Supply current, output power, and harmonics are dependent on board layout and PAOUT match.		-24		dBc	
PLL							
Frequency Range		Low Current mode (default)		286		960	MHz
		Low Phase Noise mode, LODIV = DIV12		286.7		320	
		Low Phase Noise mode, LODIV = DIV8		425		480	
		Low Phase Noise mode, LODIV = DIV4		860		960	
PLL Phase Noise		f _{RF} = 315MHz, Low Current mode (default)	f _{OFFSET} = 200kHz		-82	dBc/Hz	
			f _{OFFSET} = 1MHz		-90		
		f _{RF} = 434MHz, Low Current mode (default)	f _{OFFSET} = 200kHz		-80		
			f _{OFFSET} = 1MHz		-90		
		f _{RF} = 915MHz, Low Phase Noise mode	f _{OFFSET} = 200kHz		-82		
			f _{OFFSET} = 1MHz		-104		
LO Divider Settings				4			
				8			
				12			
Minimum Synthesizer Frequency Step				f _{XTAL} / 2 ¹⁶		Hz	
Reference Spur		f _{RF} = 315MHz	f _{RF} ± f _{XTAL}		-67	dBc	
		f _{RF} = 434MHz	f _{RF} ± f _{XTAL}		-60		
		f _{RF} = 868MHz	f _{RF} ± f _{XTAL}		-57		
		f _{RF} = 915MHz	f _{RF} ± f _{XTAL}		-56		
Reference Frequency Input Level				500		mV _{P-P}	
Frequency Switching Time		26MHz frequency step, 902MHz to 928MHz band, time from end of register write to frequency settled to within 5kHz of desired carrier		50		μs	
Loop Bandwidth	LBW			300		kHz	

Electrical Characteristics (continued)

(*Typical Application Circuit*, all RF inputs and outputs are referenced to 50Ω, V_{DD} = +1.8V to +3.6V, T_A = -40°C to +105°C, P_{OUT} = +13dBm for 300MHz–450MHz or +11dBm for 863MHz–928MHz, PA_BOOST = 0, unless otherwise noted. Typical values are at V_{DD} = +3V, T_A = +25°C, unless otherwise noted. (Note 1))

PARAMETER	SYMBOL	CONDITIONS		MIN	TYP	MAX	UNITS
LO Frequency Divider Range	N			11		72	
Turn-On Time of PLL	t _{PLL}	f _{RF} = 315MHz			30		μs
		f _{RF} = 915MHz			90		
CRYSTAL OSCILLATOR							
Crystal Frequency	f _{XTAL}	Recommended value (Note 3)		12.8	16	19.2	MHz
Crystal Oscillator Startup Time	t _{XO}	See Preset Mode Transmission section			243		μs
Frequency Pulling by V _{DD}					3		ppm/V
Crystal Input Capacitance	C _X	Internal capacitance of XTAL1 and XTAL2 pins to ground			12		pF
CMOS INPUT/OUTPUT							
Input Low Voltage	V _{IL}	SCL/SDA	1.8V compatible			0.36	V
	V _{IL_SEL}	SEL0/SEL1				0.1 x V _{DD3}	
Input High Voltage	V _{IH}	SCL/SDA	1.8V compatible	1.44			V
	V _{IH_SEL}	SEL0/SEL1		0.9 x V _{DD3}			
Input Current	I _{IL} /I _{IH}				±10		μA
Output Low Voltage	V _{OL}	I _{SINK} = 650μA			0.25		V
Output High Voltage	V _{OH}	I _{SOURCE} = 350μA			V _{DD} - 0.25		V
Maximum Capacitance at SEL0/SEL1 Pins	C _{L_SEL}				10		pF
Maximum Load Capacitance at CLKOUT/SDO Pin	C _{LOAD}				10		pF
SERIAL INTERFACE (FIGURE 1)							
SCL Clock Frequency	f _{SCL}			400		1000	kHz
Bus Free Time Between STOP and START Conditions	t _{BUF}			500			ns
Hold Time (Repeated) START Condition	t _{HD:STA}			260			ns
Low Period of SCL	t _{LOW}			500			ns
High Period of SCL	t _{HIGH}			260			ns
Data Hold Time	t _{HD:DAT}	Receive		0		150	ns
		Transmit		0			
Data Setup Time	t _{SU:DAT}			50			ns

Electrical Characteristics (continued)

(*Typical Application Circuit*, all RF inputs and outputs are referenced to 50Ω, V_{DD} = +1.8V to +3.6V, T_A = -40°C to +105°C, P_{OUT} = +13dBm for 300MHz–450MHz or +11dBm for 863MHz–928MHz, PA_BOOST = 0, unless otherwise noted. Typical values are at V_{DD} = +3V, T_A = +25°C, unless otherwise noted. (Note 1))

PARAMETER	SYMBOL	CONDITIONS	MIN	TYP	MAX	UNITS
Start Setup Time	t _{SU:STA}		260			ns
SDA and SCL Rise Time	t _R				120	ns
SDA and SCL Fall Time	t _F		20 x V _{IO} /5.5		120	ns
Stop Setup Time	t _{SU:STO}		260			ns
Noise Spike Reject	t _{SP}			25		ns

- Note 1:** Supply current, output power and efficiency are greatly dependent on board layout and PA output match.
- Note 2:** 100% tested at T_A = +25°C. Limits over operating temperature and relevant supply voltage are guaranteed by design and characterization over temperature.
- Note 3:** Guaranteed by design and characterization. Not production tested.
- Note 4:** Typical values are average, peak power is 3dB higher.
- Note 5:** Using high output power match, see [Table 3](#).

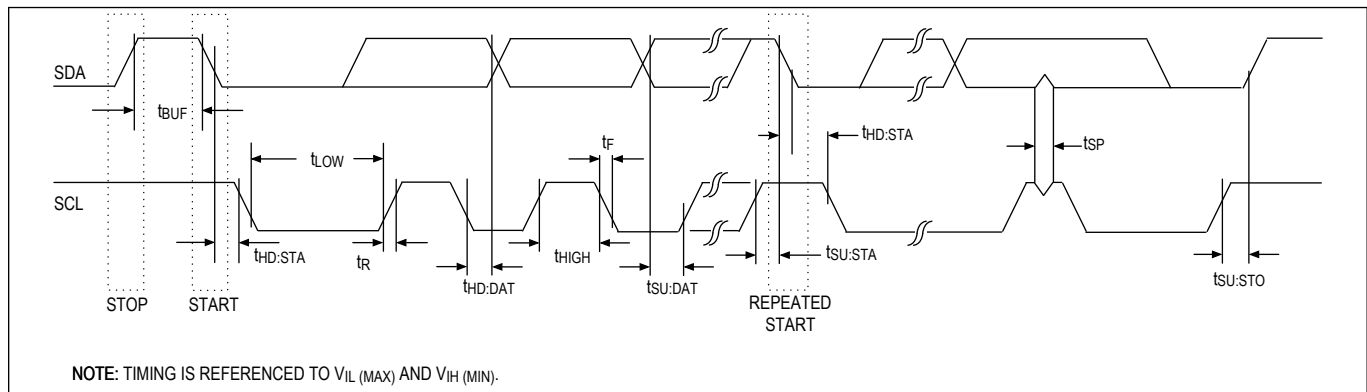
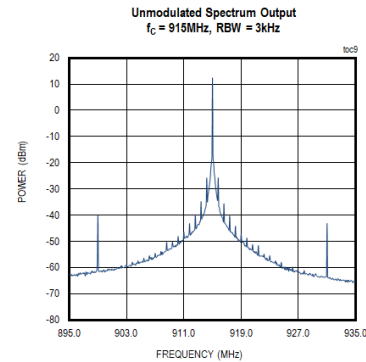
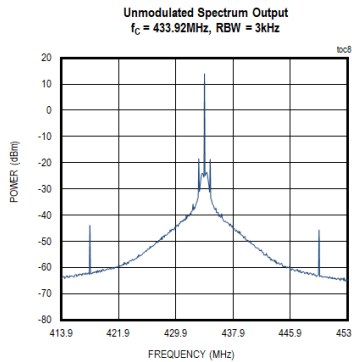
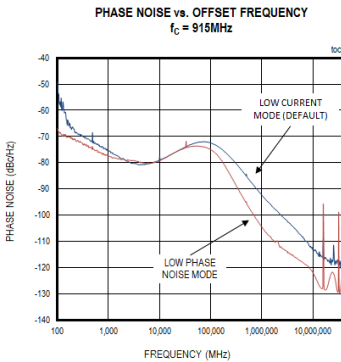
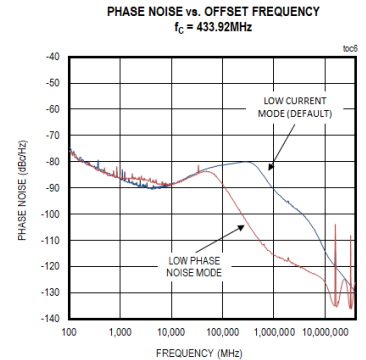
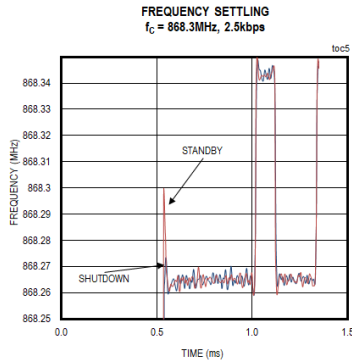
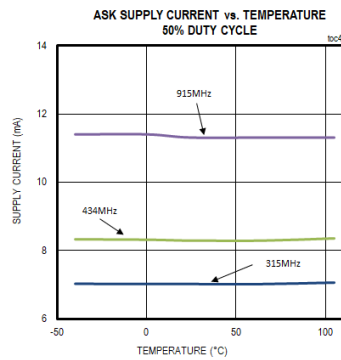
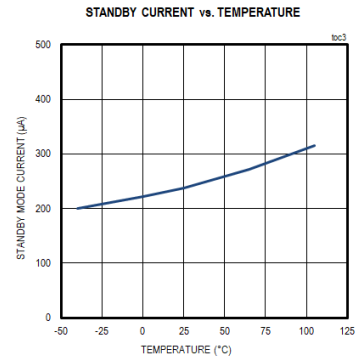
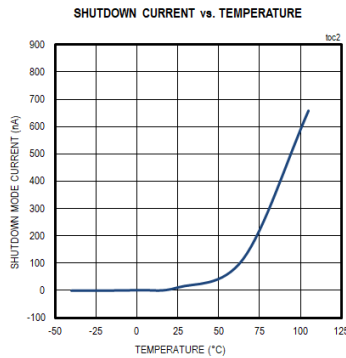
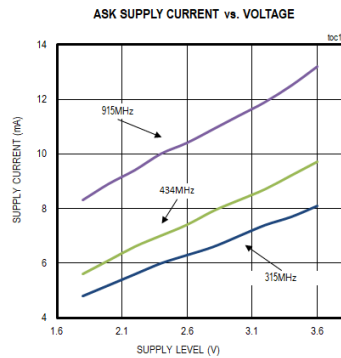

Figure 1. Serial Interface Timing Diagram

Typical Operating Characteristics

(Typical Application Circuit, RF output terminated to 50Ω. Typical values are at V_{DD} = +3V, T_A = +25°C, unless otherwise noted.)



Typical Operating Characteristics (continued)

(Typical Application Circuit, RF output terminated to 50Ω. Typical values are at V_{DD} = +3V, T_A = +25°C, unless otherwise noted.)

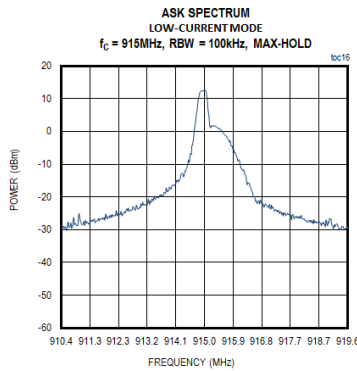
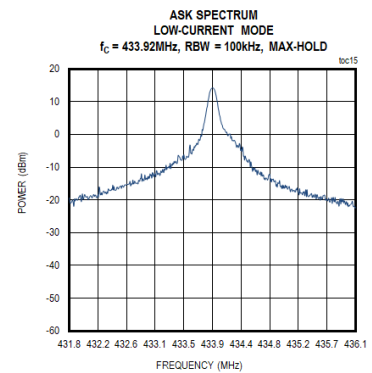
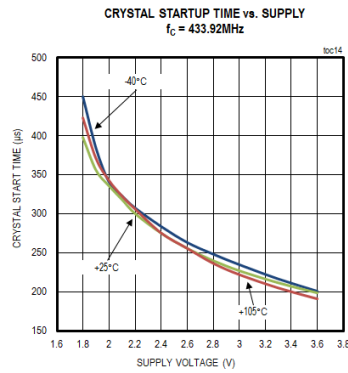
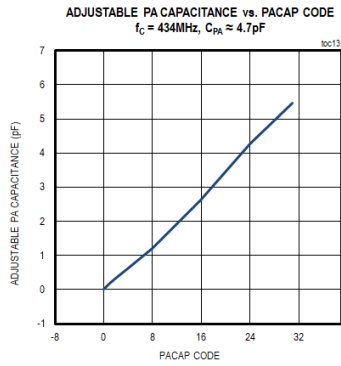
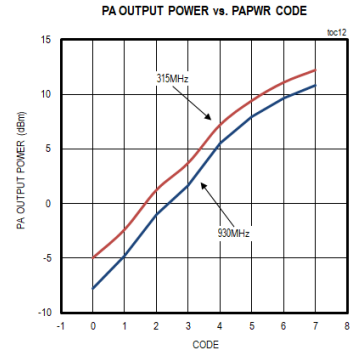
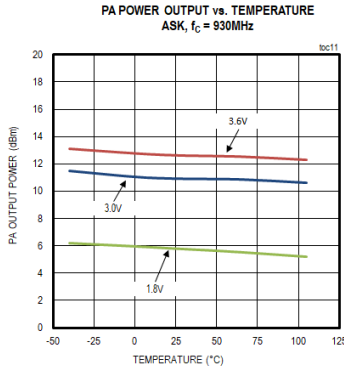
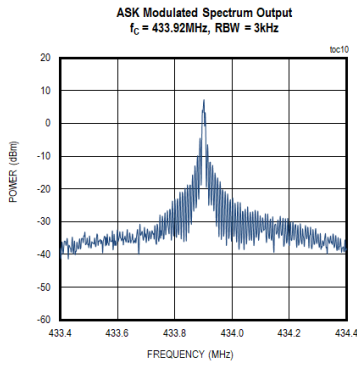

Pin Configurations

10 μ MAX

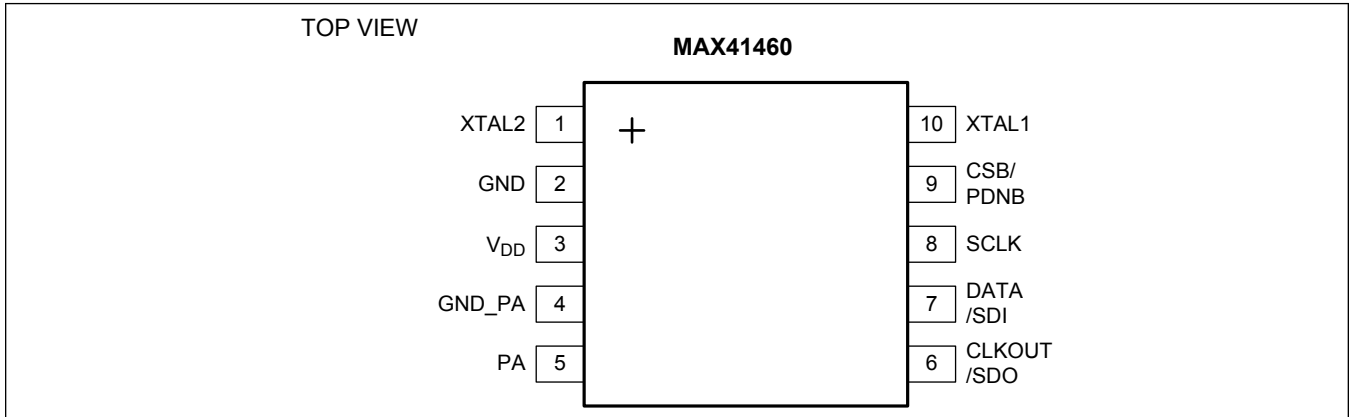

10 μ MAX

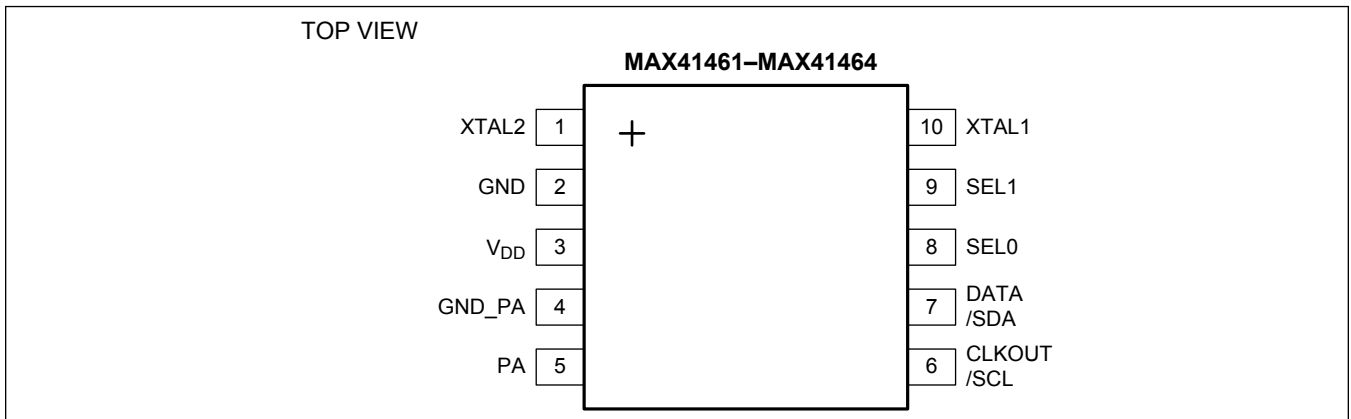

Pin Description

PIN		NAME	FUNCTION
MAX41460	MAX41461–MAX41464		
XTAL2	XTAL2	1	Second Crystal Input. See Crystal Oscillator section.
GND	GND	2	Ground. Connect to system ground.
V _{DD}	V _{DD}	3	Supply Voltage. Bypass to GND with a 100nF capacitor as close to the pin as possible.
GND_PA	GND_PA	4	Ground for the Power Amplifier (PA). Connect to system ground.
PA	PA	5	Power-Amplifier Output. The PA output requires a pullup inductor to the supply voltage, which can be part of the output-matching network to an antenna.
CLKOUT/ SDO	CLKOUT/ SCL	6	MAX41460: Buffered Clock Output or SPI Data Output. MAX41461–MAX41464: Buffered Clock Output. I ² C clock input for register programming when in Serial Interface Mode (SEL0 and SEL1 are unconnected or HIZ). The frequency of CLKOUT is 800kHz when not in Program mode.
DATA/SDI	DATA/ SDA	7	MAX41460: Data Input. SPI bus serial data input for register programming when CSB is at logic-low. MAX41461–MAX41464: Data Input. I ² C serial data input for register programming when in Serial Interface mode (SEL0 and SEL1 are unconnected or HIZ). When not in Program mode, DATA also controls the power-up state (see the <i>Auto-Shutdown in Preset Mode</i> section in the appropriate data sheet).
SCLK	SEL0	8	MAX41460: SPI Bus Serial Clock Input. MAX41461–MAX41464: Three-state Mode Input. See <i>Preset Modes</i> section in the appropriate data sheet for details. For three-state input open, the impedance on the pin must be greater than 1MΩ.
CSB	SEL1	9	MAX41460: SPI Bus Chip Enable. Active Low. MAX41461–MAX41464: Three-state Mode Input. See <i>Preset Modes</i> section in the appropriate data sheet for details. For three-state input open, the impedance on the pin must be greater than 1MΩ.
XTAL1	XTAL1	10	First Crystal Input. See Crystal Oscillator section.

Detailed Description

The MAX41461/MAX41462 is part of the MAX4146x family of UHF sub-GHz ISM/SRD transmitters designed to transmit ASK data in the 286MHz to 960MHz frequency range. The MAX4146x family is available in the following versions.

Table 1. MAX4146x Versions

VERSION	MODULATION AND INTERFACE	PRESET FREQUENCIES (MHz)
MAX41460	ASK/FSK with SPI	No presets, programmable through SPI
MAX41461	ASK (optional I ² C)	315/318/319.51/345/433.42/433.92/908/915
MAX41462	ASK (optional I ² C)	315/433/433.92/434/868/868.3/868.35/868.5
MAX41463	FSK (optional I ² C)	315/433.42/433.92/908/908.42/908.8/915/916
MAX41464	FSK (optional I ² C)	315/433.92/868.3/868.35/868.42/868.5/868.95/869.85

The MAX41460 uses an SPI programming interface. The MAX41461–MAX41464 feature an I²C interface, as well as preset modes (pin-selectable output frequencies using only one crystal frequency). No programming is required in preset modes and only a single-input data interface to an external microcontroller is needed. The MAX41461/MAX41462 parts are identical when put in I²C programming mode. All MAX4146x versions are fully programmable for all output frequencies, as described in the [Electrical Characteristics](#) table. The only frequency-dependent components required are for the external antenna match.

The crystal-based architecture of the MAX41461/MAX41462 provides greater modulation depth, faster frequency settling, higher tolerance of the transmit frequency, and reduced temperature dependence. It integrates a fractional phase-locked-loop (PLL); so a single, low-cost crystal can be used to generate commonly used world-wide sub-GHz frequencies. A buffered clock-out signal make the device compatible with almost any microcontroller or code-hopping generator.

The MAX41461/MAX41462 provides +13dBm output power into a 50Ω load at 315MHz using an integrated high efficiency power amplifier (PA). The output load can be adjusted to increase power up to +16dBm and a PA boost mode can be enabled at frequencies above 850MHz to compensate for losses. The PA output power can also be controlled using programmable register settings. The MAX41461/MAX41462 feature fast oscillator wake-up upon data activity detection and has an auto-shutdown feature to extend battery life.

The MAX41461/MAX41462 operates at a supply voltage of +1.8V to +3.6V and is available in a 10-pin μMAX package that is specified over the -40°C to +105°C extended temperature range.

Preset Modes

The MAX41461/MAX41462 contain preset settings depending on the state of pins SEL1 and SEL0. All presets must use a 16MHz crystal. The frequency of the CLKOUT pin is always 800kHz.

Table 2. Programming and Preset Modes

SEL1 STATE	SEL0 STATE	MAX41461	MAX41462
Ground	Ground	I ² C Mode	I ² C Mode
Ground	Open	315	315
Ground	V _{DD}	318	433.92
Open	Ground	319.51	433
Open	Open	345	434
Open	V _{DD}	908	868.3
V _{DD}	Ground	915	868
V _{DD}	Open	433.92	868.5
V _{DD}	V _{DD}	433.42	868.35

Preset Mode Transmission

The wake-up of the device is as follows:

- 1) The microcontroller sends a wake-up pulse on DATA. The duration of the wake-up pulse should be longer than $t_{XO} + t_{PLL}$.
- 2) After the falling edge of wake-up pulse, the microcontroller should wait for at least t_{TX} time and start data transmission. In preset mode, $t_{TX} = 10\mu s$.
- 3) CLKOUT is generated 80 μs after internal 3.2MHz clock is available.

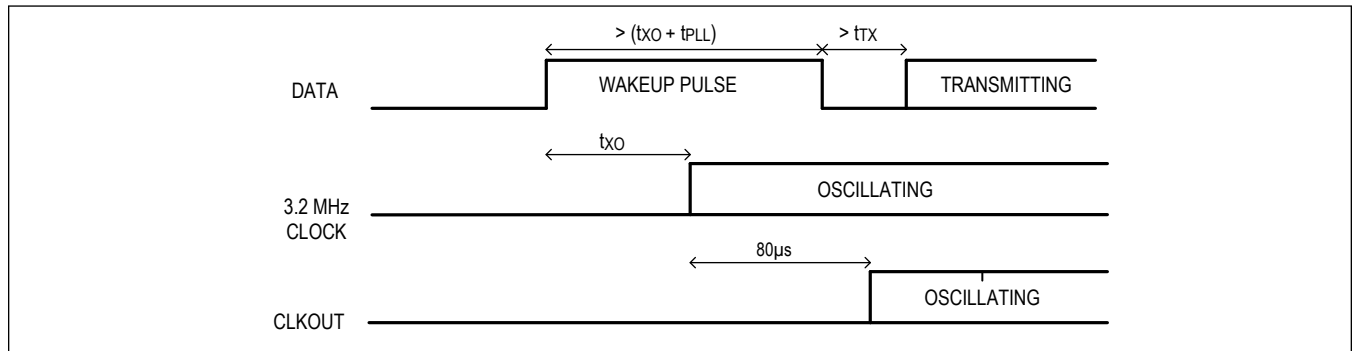

Figure 2. Wake-Up Timing Diagram for Preset Mode

Auto-Shutdown in Preset Mode

The MAX41461/MAX41462 in preset mode has an automatic shutdown feature that places the device in low-power shutdown mode if the DATA input stays at logic 0 for a wait time equal to 2^{14} cycles of the internal 3.2MHz clock. This equates to a wait time of approximately 5.1ms.

When the device is in automatic shutdown, a pulse on DATA initiates the warm up of the crystal and PLL. See [Startup](#) section for requirements on the wake-up pulse.

When the device is operating, each occurrence of logic 1 on the data line resets an internal counter to zero and it begins to count again. If the counter reaches the end-of-count, the device enters shutdown mode.

Power Amplifier

The MAX41461/MAX41462 PA is a high-efficiency, open-drain switching-mode amplifier. In a switching-mode amplifier, the gate of the final-stage FET is driven with a 25% duty-cycle square wave at the transmit frequency. The PA also has an internal set of capacitors that can be switched in and out to present different capacitance values at the PA output using the PACAP[4:0] register values. This allows extra flexibility for tuning the output matching network. When the matching network is tuned correctly, the output FET resonates the attached tank circuit (pullup inductor from PA to V_{DD}) with a minimum amount of power dissipated in the FET. With a proper output-matching network, the PA can drive a wide range of antenna impedances, which include a PCB trace antenna or a 50Ω antenna. The output-matching π -network suppresses the carrier harmonics and transforms the antenna impedance to an optimal impedance at the PA pin. The [Typical Application Circuit](#) can deliver an output power of +13dBm with a +3.0V supply. [Table 3](#) has approximate PA load impedances for desired output powers.

The PAPWR bits in the PA1 register control the output power of the PA. This setting adjust the number of parallel drivers used, which determine the final output power (see [Figure 3](#)).

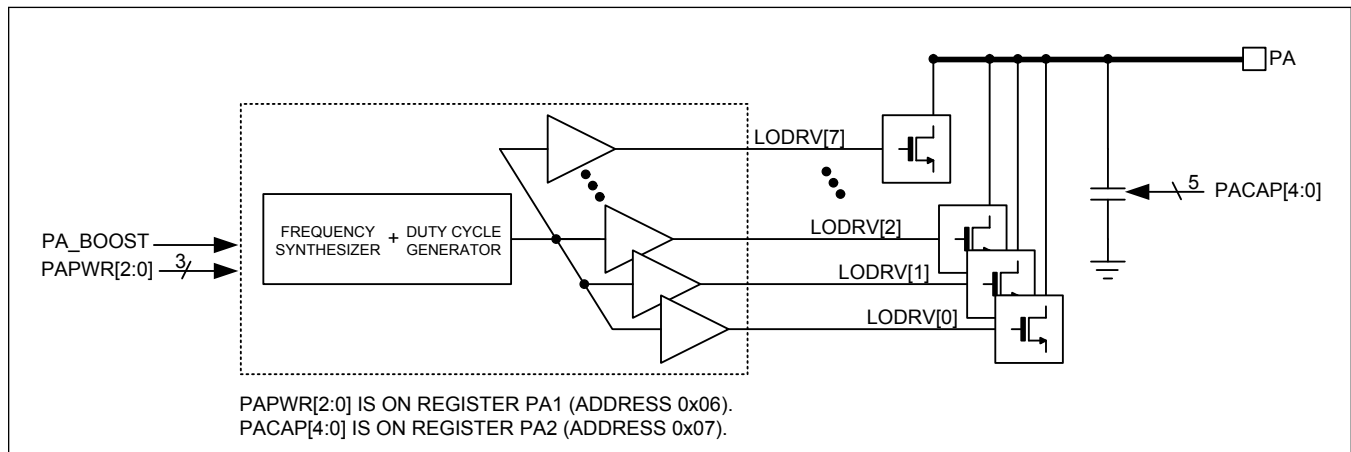

Figure 3. Power Amplifier

Boost Mode

The PA can deliver up to 16dBm of output power.

High output power can be achieved in two ways:

- Lower the load impedance for the PA by adjusting the output matching network,
- For frequencies over 850MHz, change the duty cycle of the square wave driving the PA from 25% to 50% by setting PA_BOOST = 1 in register SHDN (0x05) and adjusting the output matching network.

Note that, when using PA_BOOST = 1, the maximum supply voltage should not exceed 3V. For frequencies under 850MHz, the PA_BOOST bit should remain at 0, the output match can be adjusted to provide higher output power.

Table 3. PA Load Impedance for Desired Output Power

FREQUENCY (MHz)	OUTPUT POWER (dBm)	PA LOAD IMPEDANCE (Ω)
315	13	165
315	16 (PA_BOOST = 0)	45
434	13	180
434	16 (PA_BOOST = 0)	57
863–928	11	190
863–928	16 (PA_BOOST = 1)	34

Refer to the *MAX4146x EV Kit User's Guide* for details.

Programmable Output Capacitance

The MAX41461/MAX41462 has an internal set of capacitors that can be switched in and out to present different capacitor values at the PA output. The capacitors are connected from the PA output to ground. This allows changing the tuning network along with the synthesizer divide ratio each time the transmitted frequency changes, making it possible to maintain maximum transmitter power while moving rapidly from one frequency to another.

The variable capacitor is programmed through register PA2 (0x07) bits 4:0 (PACAP). The tuning capacitor has a nominal resolution of 0.18pF, from 0pF to 5.4pF. In preset mode, the variable capacitor is set to 0pF.

Transmitter Power Control

The transmitter power of the MAX41461/MAX41462 can be set in approximately 2.5dB steps by setting PAPWR[2:0] register bits using the I²C interface. The transmitted power (and the transmitter current) can be lowered by increasing the load impedance on the PA. Conversely, the transmitted power can be increased by lowering the load impedance.

Preset Mode Output Power

The output power of the PA in Preset mode (where both SEL0 and SEL1 pins are not connected to GND) is always set for maximum power level (PAPWR[2:0] = 0x7) for a given load impedance. In order to adjust output power levels in preset mode, the load impedance must be adjusted accordingly.

Crystal (XTAL) Oscillator

The XTAL oscillator in the MAX41461/MAX41462 is designed to present a capacitance of approximately 12pF from the XTAL1 and XTAL2 pins to ground. In most cases, this corresponds to a 6pF load capacitance applied to the external crystal when typical PCB parasitics are included. It is very important to use a crystal with a load capacitance equal to the capacitance of the MAX41461/MAX41462 crystal oscillator plus PCB parasitics. If a crystal designed to oscillate with a different load capacitance is used, the crystal is pulled away from its stated operating frequency introducing an error in the reference frequency. The crystal's natural frequency is typically below its specified frequency. However, when loaded with the specified load capacitance, the crystal is pulled and oscillates at its specified frequency. This pulling is already accounted for in the specification of the load capacitance. Accounting for typical board parasitics, a 16MHz, 12pF crystal is recommended. Please note that adding discrete capacitance on the crystal also increases the startup time and adding too much capacitance could prevent oscillation altogether.

Additional pulling can be calculated if the electrical parameters of the crystal are known. The frequency pulling is given by:

$$f_P = \frac{C_M}{2} \left(\frac{1}{C_{CASE} + C_{LOAD}} - \frac{1}{C_{CASE} + C_{SPEC}} \right) \times 10^6$$

where:

f_P is the amount the crystal frequency pulled in ppm.

C_M is the motional capacitance of the crystal.

C_{CASE} is the case capacitance.

C_{SPEC} is the specified load capacitance.

C_{LOAD} is the load capacitance.

When the crystal is loaded as specified (i.e., $C_{LOAD} = C_{SPEC}$), the frequency pulling equals zero. For additional details on crystal pulling and load capacitance affects, refer to *Maxim Tutorial 5422 – Crystal Calculations for ISM RF Products*.

Turn-On Time of Crystal Oscillator

The turn-on time of crystal oscillator (XO), t_{XO} , is defined as elapsed time from the instant of turning on XO circuit to the first rising edge of XO divider clock output. The external microcontroller turns on the XO by,

1. Sending a wakeup pulse for MAX41461–MAX41464 in the preset mode, or
2. Writing to device I²C address for MAX41461–MAX41464 in the I²C mode, or
3. Pulling CSB pin low on the MAX41460.

Crystal Divider

The recommended crystal frequencies are 13.0MHz, 16.0MHz, and 19.2MHz. An internal clock of 3.2MHz±0.1MHz frequency is required. To maintain the internal 3.2MHz time base, XOCLKDIV[1:0] (register CFG1, 0x00, bit 4) must be programmed, based on the crystal frequency, as shown in [Table 4](#).

Table 4. Required Crystal Divider Programming

CRYSTAL FREQUENCY (MHz)	Crystal Divider Ratio	XOCLKDIV[1:0]
13.0	4	00
16.0	5	01
19.2	6	10

Crystal Frequency in Preset Mode

For MAX41461/MAX41462 in preset mode (where *both* SEL0 and SEL1 pins are *not* connected to GND), crystal frequency must be 16MHz to ensure accurate output frequency.

Phase-Locked Loop (PLL)

The MAX41461/MAX41462 utilizes a fully integrated fractional-N PLL for its frequency synthesizer. All PLL components, including loop filter, are included on-chip. The synthesizer has a 16-bit fractional-N topology with a divide ratio that can be set from 11 to 72, allowing the transmit frequency to be adjusted in increments of $f_{XTAL}/65536$. The fractional-N architecture also allows exact FSK frequency deviations to be programmed. FSK deviations as low as ± 1 kHz and as high as ± 100 kHz can be set by programming the appropriate registers.

The internal VCO can be tuned continuously from 286MHz to 960MHz in normal mode, and from 286MHz–320MHz, 425MHz–480MHz, and 860MHz–960MHz in low phase noise mode.

Frequency Programming

The desired frequency can be programmed by setting bits **FREQ** in registers PLL3, PLL4, and PLL5 (0x0B, 0x0C, 0x0D). To calculate the **FREQ** bits, use:

$$\text{FREQ}[23 : 0] = \text{ROUND}\left(\frac{65536 \times f_C}{f_{XTAL}}\right)$$

See [Table 5](#) to program the **LODIV** bits in register PLL1 (0x08) when choosing a LO frequency. It is recommended to leave bits **CPVAL** and **CPLIN** at factory defaults. If integer-N synthesis is desired, set bit **FRACMODE** = 0 in register PLL1.

Table 5. LODIV Setting

FREQUENCY RANGE (MHz)	LODIV SETTING
286–960, Low Current Mode	0x0
286–320, Low Phase Noise Mode	0x3
425–480, Low Phase Noise Mode	0x2
860–960, Low Phase Noise Mode	0x1

Fractional-N Spurs

The 16-bit fractional-N, delta-sigma modulator can produce spurious that can show up on the power amplifier output spectrum. If slight frequency offsets can be tolerated, set the LSB of **FREQ** (register PLL5, bit 0) to logic-high. Using an odd value (logic 1 at bit 0) of the 24-bit **FREQ** register will produce lower PLL spurious compared to even values (logic 0 at bit 0).

Turn-On Time of PLL

The turn-on time of PLL, t_{PLL} , is defined as the elapsed time from the instant when the XO output is available to the instant when PLL frequency acquisition is complete.

Two-Wire I²C Serial Interface

When pins SEL0 and SEL1 are grounded, the MAX41461/MAX41462 features a 2-wire I²C-compatible serial interface consisting of a serial-data line (SDA) and a serial-clock line (SCL). SDA and SCL facilitate bidirectional communication between the MAX41461/MAX41462 and the master at clock frequencies up to 1MHz. The master device initiates a data transfer on the bus and generates the SCL signal to permit data transfer. The MAX41461/MAX41462 functions as an I²C slave device that transfers and receives data to and from the master. Pull SDA and SCL high with external pullup resistors of 1kΩ or greater, referenced to V_{DD} for proper I²C operation.

One bit transfers during each SCL clock cycle. A minimum of nine clock cycles is required to transfer a byte into or out of the MAX41461/MAX41462 (8 bits and an ACK/NACK). The data on SDA must remain stable during the high period of the SCL clock pulse. Changes in SDA while SCL is high and stable are considered control signals (see the [START and STOP Conditions](#) section). Both SDA and SCL remain high when the bus is not busy.

[Figure 4](#) and [Figure 5](#) show I²C Write transaction and I²C Read transaction protocols, respectively.

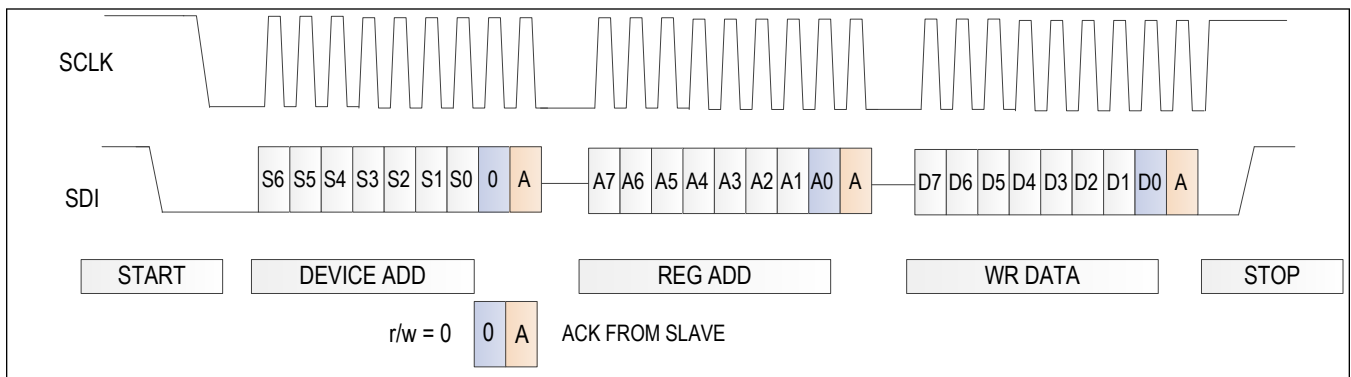

Figure 4. I²C Write

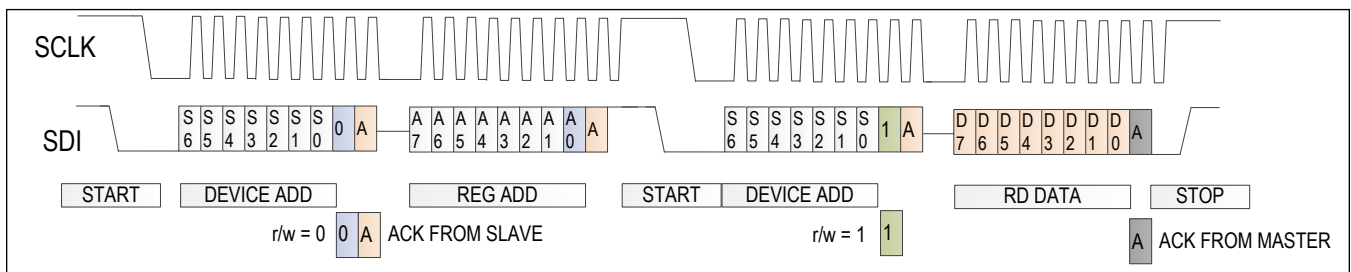

Figure 5. I²C Read

START and STOP Conditions

The master initiates a transmission with a START condition (S), which is a high-to-low transition on SDA while SCL is high. The master terminates a transmission with a STOP condition (P), which is a low-to-high transition on SDA while SCL is high.

Acknowledge and Not-Acknowledge Conditions

Data transfers are framed with an acknowledge bit (ACK) or a not-acknowledge bit (NACK). Both the master and the MAX41461/MAX41462 (slave) generate acknowledge bits. To generate an acknowledge, the receiving device must pull SDA low before the rising edge of the acknowledge-related clock pulse (ninth pulse) and keep it low during the high period of the clock pulse.

To generate a not-acknowledge condition, the receiver allows SDA to be pulled high before the rising edge of the

acknowledge-related clock pulse, and leaves SDA high during the high period of the clock pulse. Monitoring the acknowledge bits allows for detection of unsuccessful data transfers. An unsuccessful data transfer happens if a receiving device is busy or if a system fault has occurred. In the event of an unsuccessful data transfer, the bus master must reattempt communication at a later time.

Slave Address

The MAX41461/MAX41462 has a 7-bit I²C slave address that must be sent to the device following a START condition to initiate communication. The slave address is internally programmed to 0xD2 for WRITE and 0xD3 for READ. The MAX41461/MAX41462 continuously awaits a START condition followed by its slave address. When the device recognizes its slave address, it acknowledges by pulling the SDA line low for one clock period, then it is ready to accept or send data, depending on the R/W bit.

Write Cycle

When addressed with a write command, the MAX41461/MAX41462 allows the master to write to either a single register or to multiple successive registers.

A write cycle begins with the bus master issuing a START condition, followed by the 7 slave address bits and a write bit (R/W = 0). The MAX41461/MAX41462 issues an ACK if the slave address byte is successfully received. The bus master must then send the address of the first register it wishes to write to (see [Register Map](#)). The slave acknowledges the address and the master can then write one byte to the register at the specified address. Data is written beginning with the most significant bit (MSB). The MAX41461/MAX41462 again issues an ACK if the data is successfully written to the register.

The master can continue to write data to the successive internal registers with the MAX41461/MAX41462 acknowledging each successful transfer, or the master can terminate transmission by issuing a STOP condition. The write cycle does not terminate until the master issues a STOP condition.

[Figure 6](#) illustrates I²C Burst Write transaction protocol.

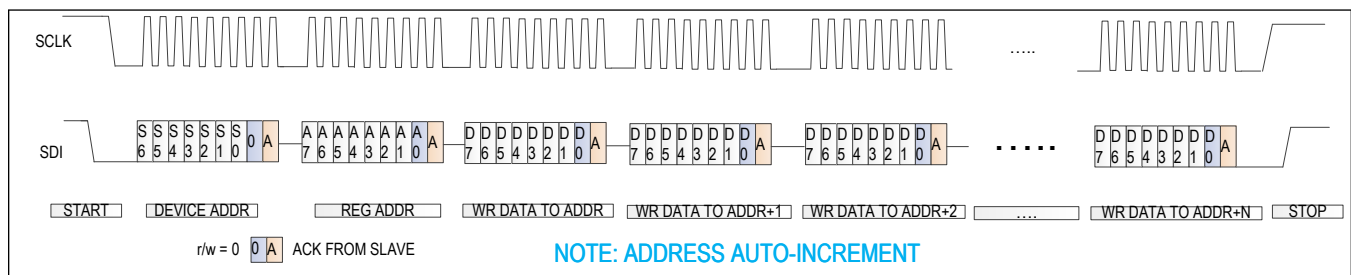

Figure 6. I²C Burst Write

Read Cycle

When addressed with a read command, the MAX41461/MAX41462 allows the master to read back a single register or multiple successive registers.

A read cycle begins with the bus master issuing a START condition, followed by the 7 slave address bits and a write bit (R/W = 0). The device issues an ACK if the slave address is successfully received. The bus master must then send the address of the first register it wishes to read. The slave acknowledges the address. A START condition is then issued by the master, followed by the 7 slave address bits and a read bit (R/W = 1). The device issues an ACK if the slave address byte is successfully received. The device starts sending data MSB first with each SCL clock cycle. At the 9th clock cycle, the master can issue an ACK and continue to read successive registers, or the master can terminate the transmission by issuing a NACK. The read cycle does not terminate until the master issues a STOP condition.

Buffered Clock Output

MAX41461/MAX41462 provides a buffered clock output (CLKOUT) on pin 6 of the chip in the preset mode, and the frequency of CLKOUT is 800 kHz. In I²C mode, MAX41461/MAX41462 uses pin 6 as the SCL line of the I²C interface.

CLKOUT_DELAY[1:0] (register CFG2, address 0x01, bits 7:6) is only used in the preset modes, with a preset value of 0x02. These two register bits are not used in programming mode.

State Diagrams

In the I²C programming mode, the device has four major states: shutdown, standby, programming, and transmitter-enabled. These states describe the power-on or power-off status of the transmitter's three primary internal circuit blocks: the crystal oscillator (XO), the PLL synthesizer, and the power amplifier (PA).

Table 6. State Descriptions

State	XO	PLL	PA
Shutdown	Off	Off	Off
Standby	On	Off	Off
Programming	On	On	Off
Transmitter-Enabled	On	On	On with Ramp-up

Configuration register values are retained in all states unless changed by programming, or if the device is powered off or undergoes a SOFTRESET.

A wake-up byte with 7-bit device address from the I²C bus initiates the warm-up of the XO and PLL.

The device can support two types of I²C transactions: register access only, and register access followed by data transmission. The event trigger of data transmission is a rising edge on I2C_TXEN, which is a special signal with two register-bit aliases I2C_TXEN1 (register CFG6, 0x0A, bit 2) and I2C_TXEN2 (register CFG7, 0x10, bit 2). A rising edge on I2C_TXEN can be generated by clearing I2C_TXEN1 and setting I2C_TXEN2 in a single I²C transaction.

I2C_TXEN is automatically cleared in two cases: 1) wake-up from shutdown, 2) return to programming state from the transmitter-enabled state. In those two cases, a rising edge on I2C_TXEN can be generated by setting I2C_TXEN2 in CFG7, without explicit clearing of I2C_TXEN1.

Data to be transmitted are written into a special register, byte I2C_TX_DATA[7:0] (register I2C3, 0x13, bits 7:0). Automatic incrementing of addresses in I²C burst write are disabled for this special register. Each data byte written into I2C_TX_DATA will be transferred into a FIFO buffer. The device has an internal 1-bit signal FIFO_STOP. At the end of data transmission, FIFO_STOP is set, and the device references the PWDN_MODE[1:0] (register CFG4, 0x03, bits 1:0) to enter shutdown, standby, or programming state. The shutdown and standby states can only be entered after the transmitter-enabled state.

In both the shutdown and standby states, programming through the I²C interface is not allowed. The device will exit the shutdown or standby state once its 7-bit I²C address is received.

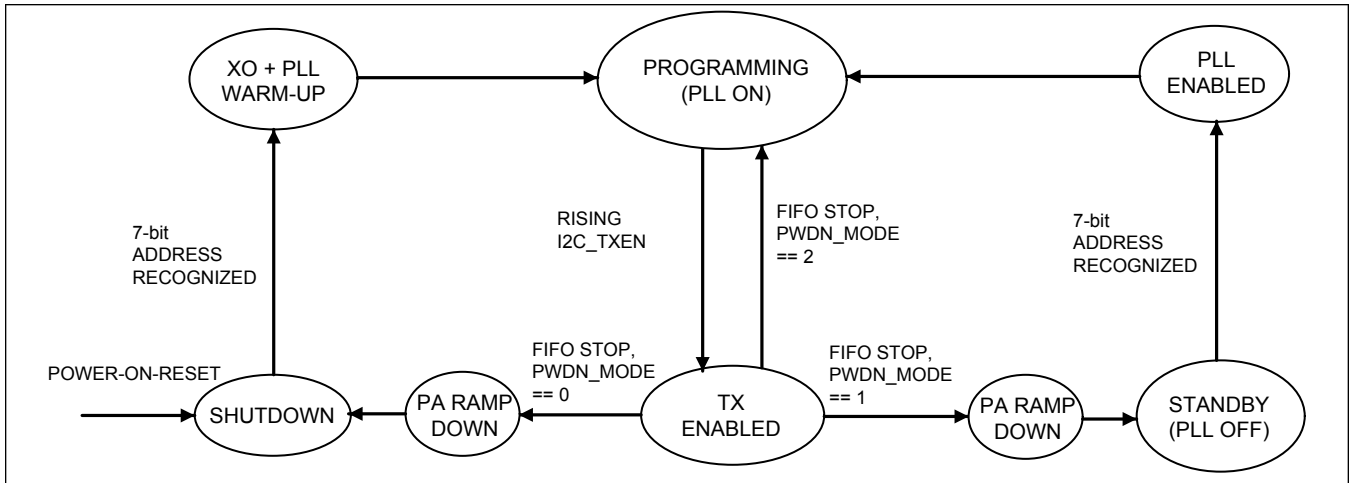

Figure 7. Simplified State Diagram in Programming Mode

In the preset mode, the MAX41461/MAX41462 device has two major states: shutdown, and transmitter-enabled. After power is applied, the device enters the shutdown state, refer to [Initial Programming](#). A rising edge on DATA (pin 7) initiates the warm-up of the XO and PLL. After PLL is locked, a falling edge on DATA enables the transmitter. The device returns to shutdown state when there is no DATA activity, (i.e., DATA stays at 0 for 16384 cycles of the internal 3.2MHz clock).

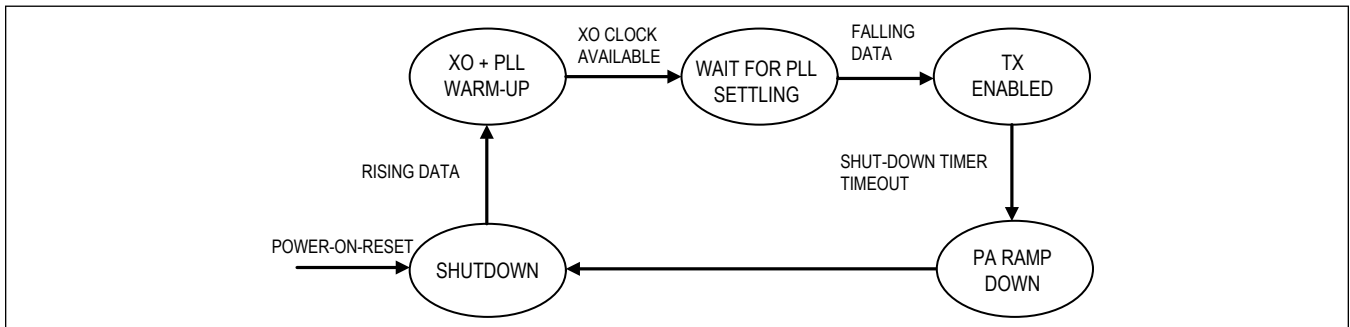

Figure 8. State Diagram in Preset Mode

Initial Programming

After turning on power supply (or a soft reset), two I²C transactions are required to initialize the PLL frequency synthesizer. The first transaction ensures register ADDL2 at address 0x1A is written to its default of 0x80. The second transaction burst-writes 20 consecutive registers from address 0x00 to 0x13.

The device needs to transmit an 8-bit dummy packet for initial programming. The initial programming must clear MODMODE (register CFG1, address 0x00, bit 0), clear I2C_TXEN1 (register CFG6, address 0x0A, bit 2), configure FREQ[23:0] (register PLL3, PLL4 and PLL5) to desired frequency, set I2C_TXEN2 (register CFG7, address 0x10, bit 2), and configure I2C_TX_DATA[7:0] (register I2C3, address 0x13) to 0x00. In addition, BCLK_POSTDIV[2:0], BCLK_PREDIV[7:0], and PKTLEN_MODE should be configured to default values in the register map.

Initial programming cannot be completed by a single burst-write transaction because the I2C_TX_DATA register at address 0x13 is a special register that disables automatic address increment. However, two I²C transactions may be merged to a combined transaction, where each write begins with a START mark and the slave address.

After initial programming, the device will enter the shutdown, standby, or programming state according to the setting of PWDN_MODE[1:0] (register CFG4, address 0x03, bit[1:0]).

Startup

Programming Mode

This section assumes that initial programming is done after power on (or soft reset). Configuration register values are retained in all states unless changed by programming, or if the device is powered off or undergoes a SOFTRESET.

Case 1: Using Two I²C Transactions for Startup from Shutdown

The startup of MAX41461/MAX41462 in programming mode, from shutdown state, uses two I²C transactions: one for configuration update, and the other for data transmission.

In the first I²C transaction, the master device burst-writes consecutive registers that are a portion or all of the 16 registers from address 0x00 to 0x0F. Those consecutive registers may or may not include CFG6. If CFG6 is included, the I2C_TXEN1 bit should be cleared; otherwise, I2C_TXEN1 is automatically cleared in the wake-up from shutdown.

In the second I²C transaction, the master device can set I2C_TXEN2 (register CFG7, address 0x10, bit 2), configure PKTLEN_MODE (register I2C1, address 0x11, bit 7) and PKTLEN[14:0], and write the data to be transmitted into I2C_TX_DATA (register I2C3, address 0x13). Automatic increment of register address during burst write is disabled at address 0x13.

The event-trigger for wake-up is the recognition of I²C address of the MAX41461/MAX41462 device. The event trigger for data transmission is the rising edge I2C_TXEN that has two aliases of I2C_TXEN1 and I2C_TXEN2. The time lag between those two triggers must be longer than $t_{XO} + t_{PLL}$. To meet this requirement, the master device can adjust the waiting time between two I²C transactions.

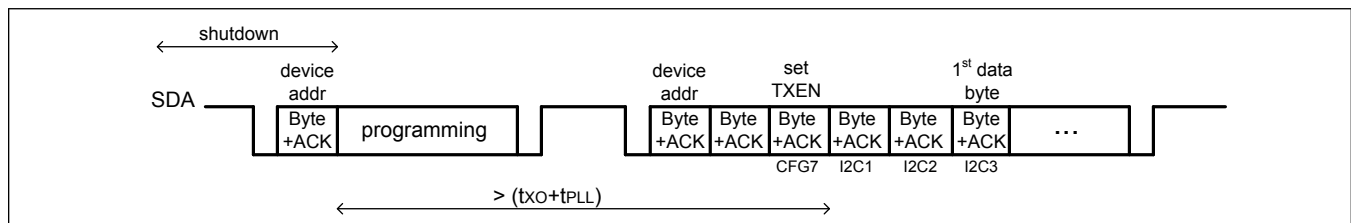

Figure 9. Using Two I²C Transactions to Start Data Transmission From the Shutdown State

Case 2: Using a Single I²C Transactions for Startup from Shutdown (recommended for use with I²C Fast Mode)

From shutdown state, the start-up of device in programming mode may use a single I²C transaction to burst-write consecutive registers starting from address 0x00. Data to be transmitted are written into I2C_TX_DATA (register I2C3, address 0x13). Automatic increment of register address during burst write is disabled at address 0x13. The programming should clear I2C_TXEN1 and set I2C_TXEN2.

The event-trigger for wake-up is the recognition of I²C address of the device. The event-trigger for data transmission is the rising edge of I2C_TXEN that two aliases of I2C_TXEN1 and I2C_TXEN2. The time lag between those two triggers, here 162 cycles of SCL, must be longer than $t_{XO} + t_{PLL}$. To meet this requirement, the fast-mode I²C with 400kHz SCL is recommended.

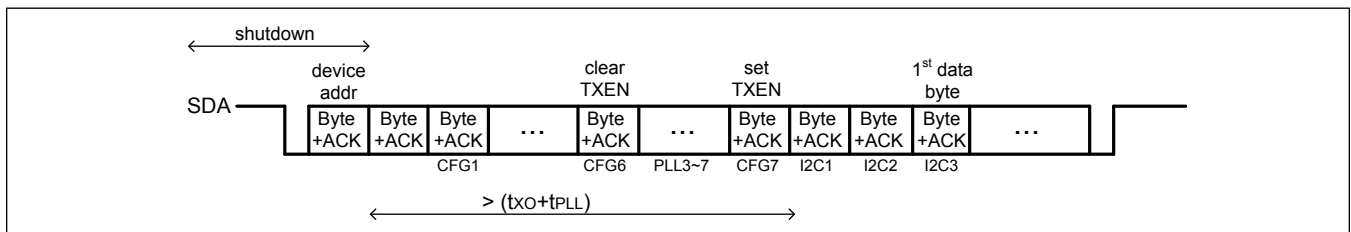

Figure 10. Using a Single I²C Transaction to Start Data Transmission From the Shutdown State

Case 3: Using a Combined I²C Transaction for Startup from Shutdown (recommended for use with most I²C clock rates)

From shutdown state, the startup of MAX41461/MAX41462 in programming mode can use a combined I²C transaction with repeated START marks. In a combined transaction, the master device can do multiple read/write operations without losing control to other master devices on the I²C bus. For example, the combined transaction can have a burst-read operation followed by a burst-write operation.

In the burst-write operation, the master device should write consecutive registers starting from CFG7 (address 0x10) or any register preceding CFG7. Data to be transmitted are written into I2C_TX_DATA (register I2C3, address 0x13). Automatic incrementing of register addresses during burst-write is disabled at address 0x13. The programming should set I2C_TXEN2 (and clear I2C_TXEN1 if CFG6 is included in the registers to write).

The event-trigger for wake-up is the recognition of device address in the burst-read operation. The event-trigger for data transmission is the rising edge of I2C_TXEN that has two aliases of I2C_TXEN1 and I2C_TXEN2. The time lag between those two triggers must be longer than $t_{XO} + t_{PLL}$. To meet this requirement, the master device can adjust the number of registers to read in the burst-read operation.

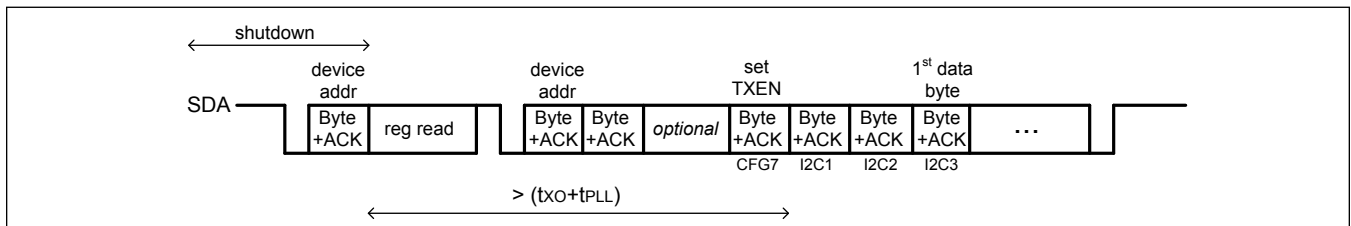

Figure 11. Using a Combined I²C Transaction to Start Data Transmission From the Shutdown State

Case 4: Using a Single I²C Transactions for Startup from Standby (recommended for use with I²C Fast-mode and I²C Fast-mode Plus)

From standby state, the startup of MAX41461/MAX41462 in programming mode can use a single I²C transaction to burst-write consecutive registers starting from CFG6 (address 0x0A) or any register preceding CFG6. Data to be transmitted are written into I2C_TX_DATA (register I2C3, address 0x13). Automatic incrementing of register addresses during burst-write is disabled at address 0x13. The programming should clear I2C_TXEN1 and set I2C_TXEN2.

The event-trigger for wake-up is the recognition of I²C address of the device. The event-trigger for data transmission is the rising edge of I2C_TXEN that two aliases of I2C_TXEN1 and I2C_TXEN2. The time lag between those two triggers, here ≥ 72 cycles of SCL, must be longer than t_{PLL} for startup from standby. This requirement is met for the fast-mode I²C with 400kHz SCL. In the case of Fast-mode Plus I²C with 1MHz SCL, the master device can burst-write registers starting from PLL1.

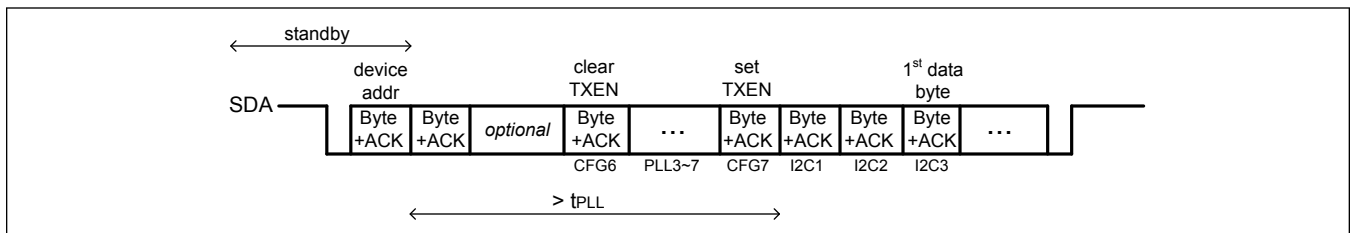

Figure 12. Using a Single I²C Transaction to Start Data Transmission From the Standby State

Case 5: Using a Single I²C Transactions for Startup from Programming

The MAX41461/MAX41462 device can transmit a data packet each time in the transmitter-enabled state. After data transmission, the device refers to the setting of PWDN_MODE[1:0] to enter the shutdown, standby, or programming state. If the next data packet requires fast start-up, PWDN_MODE[1:0] can be configured to 0x10 so that the device returns to the programming state.

Then, the master device can use a single I²C transaction to burst-write consecutive registers starting from CFG7 (address 0x10) or any register preceding CFG7. Data to be transmitted are written into I2C_TX_DATA (register I2C3, address 0x13). Automatic incrementing of register addresses during burst-write is disabled at address 0x13. The programming should set I2C_TXEN2 (and clear I2C_TXEN1 if CFG6 is included in the registers to write). There is no restrictions arising from t_{XO} and t_{PLL} .

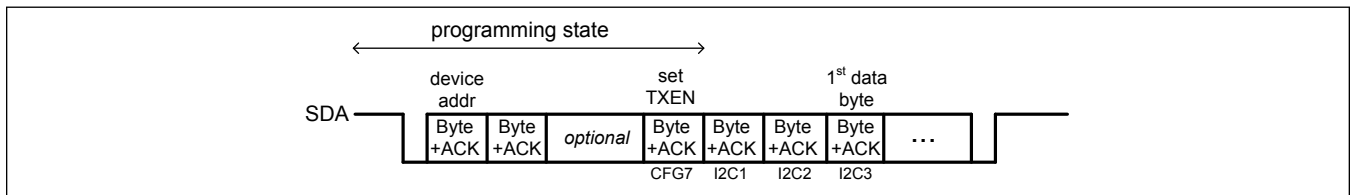

Figure 13. Using a Single I²C Transaction to Start Data Transmission From the Programming State

FIFO Buffer

The I²C interface is a bus connected to multiple master or slave devices. The microcontroller is a master device and the MAX41461/MAX41462 is a slave device. The microcontroller can initiate communication with the slave device by I²C addressing (e.g., sending a START mark followed by 7-bit device address). The slave device is required to acknowledge every byte transferred through I²C.

For data transmission, the microcontroller can burst-write consecutive registers, including CFG7 and I2C3. The purpose of writing CFG7 is to set I2C_TXEN2 and, therefore, generate a trigger to enable the transmitter. Automatic increment of register address in I²C burst-write is disabled for the I2C3 register, which is also named I2C_TX_DATA. Once the transmitter is enabled, all bytes written to I2C_TX_DATA are moved into a FIFO buffer. The buffer size is 4 bytes. The FIFO buffer is enabled only in the transmitter-enabled state.

A programmable baud-rate clock is used for retrieving and transmitting bits from the FIFO buffer. The baud rate is programmable by BCLK_PREDIV[7:0] (register CFG3, 0x02, bits 7:0) and BCLK_POSTDIV[2:0] (register CFG2, 0x01, bits 2:0) as the following expression:

$$\text{BaudRate} = \frac{f_{\text{CLK}}}{2 \times (1 + \text{BCLK_PREDIV}) \times 2^{\text{BCLK_POSTDIV}}}$$

where f_{CLK} is the crystal-divider output clock rate (nominally, 3.2 MHz). Valid values of BCLK_PREDIV are from 3 to 255. Valid values of BCLK_POSTDIV are from 1 to 5.

To avoid underflow of the FIFO buffer, the baud-rate must be lower than 8/9 of the SCL clock rate. The device can support three modes of SCL clock frequencies: 100kHz, 400kHz, and 1MHz. In the 100kHz mode, it is recommended to limit baud-rate to no more than 50kbps.

A FIFO overflow is avoided by utilizing the I²C clock stretching mechanism. Clock stretching is done before the ACK bit. There is no clock-stretching timeout.

Each time before data transmission, the I2C1 and I2C2 registers are configured to specify PKTLEN_MODE and PKTLEN[14:0]. Data transmission stops when PKTLEN_MODE is set and the number of bauds transmitted is equal to PKTLEN[14:0]. Data transmission also stops at FIFO underflow or overflow. An internal 1-bit flag FIFO_STOP is set at the end of data transmission. The rising edge of FIFO_STOP serves as the event trigger to disable the transmitter. See [State Diagrams](#) section.

When the number of bauds to be transmitted is known before data transmission and less than 32768, it is recommended to set PKTLEN_MODE and configure PKTLEN[14:0] as the number of bauds to be transmitted. Otherwise, clear PKTLEN_MODE and utilize FIFO underflow to stop data transmission. Once the microcontroller stops writing I2C_TX_DATA, FIFO underflow will occur after the data stored in FIFO buffer are transmitted.

Read-only register I2C4, I2C5, and I2C6 are provided to report diagnostic information for the FIFO buffer.

Frequency-Hopping

In programming mode, the frequency synthesizer is initialized to a frequency in a selected ISM band by initial programming. After that, for the purpose of frequency dithering or frequency hopping, the `FREQ[23:0]` registers can be updated to a new frequency in the same selected band for each data packet to be transmitted.

Because programming is not allowed in the transmitted-enabled state (see [State Diagrams](#) section), frequency configuration cannot be changed when PA is enabled. See [Startup](#) section for details on how to program the device for data transmission.

After transmitting a data packet, the device enters the shutdown, standby, or programming state according to the setting of `PWDN_MODE[1:0]` register. The three options have different startup time for transmitting the next data packet.

The startup time from shutdown is at least $(t_{XO} + t_{PLL} + t_{TX})$, where t_{XO} is the turn-on time of crystal oscillator, t_{PLL} is the turn-on time of PLL, t_{TX} is the turn-on time of transmitter.

The startup time from standby is at least $(t_{PLL} + t_{TX})$.

The t_{TX} time is 27 cycles of the SCL clock plus 2 cycles of the baud-rate clock. For example, the SCL clock rate is 1MHz, the baud rate is 100kb/s, the value of t_{TX} is 47 μ s. See [Electrical Characteristics](#) table for typical values of t_{XO} and t_{PLL} .

Register Map

Register Map

ADDRESS	NAME	MSB						LSB	
TX									
0x00	CFG1[7:0]	XOCLKDELAY[1:0]		XOCLKDIV[1:0]		–	FSKSHAPE	SYNC	MODMODE
0x01	CFG2[7:0]	CLKOUT_DELAY[1:0]		–	–	–	BCLK_POSTDIV[2:0]		
0x02	CFG3[7:0]	BCLK_PREDIV[7:0]							
0x03	CFG4[7:0]	–	–	–	–	–	PWDN_MODE[1:0]		
0x04	CFG5[7:0]	–	–	RESERVED[5:0]					
0x05	SHDN[7:0]	–	–	–	–	–	RESERVED	RESERVED	PA_BOOST
0x06	PA1[7:0]	RESERVED[2:0]			–	–	PAPWR[2:0]		
0x07	PA2[7:0]	–	–	–	PACAP[4:0]				
0x08	PLL1[7:0]	CPLIN[1:0]		FRACMODE	RESERVED[1:0]		LODIV[1:0]	LOMODE	
0x09	PLL2[7:0]	RESERVED	RESERVED	–	–	–	CPVAL[1:0]		
0x0A	CFG6[7:0]	–	–	–	–	–	I2C_TXEN1	RESERVED	RESERVED
0x0B	PLL3[7:0]	FREQ[23:16]							
0x0C	PLL4[7:0]	FREQ[15:8]							
0x0D	PLL5[7:0]	FREQ[7:0]							
0x0E	PLL6[7:0]	–	DELTAFA[6:0]						
0x0F	PLL7[7:0]	–	–	–	–	DELTAFA_SHAPE[3:0]			
0x10	CFG7[7:0]	–	–	–	–	–	I2C_TXEN2	RESERVED	RESERVED
0x11	I2C1[7:0]	PKTLEN_MODE	PKTLEN[14:8]						
0x12	I2C2[7:0]	PKTLEN[7:0]							
0x13	I2C3[7:0]	I2C_TX_DATA[7:0]							
0x14	I2C4[7:0]	PKTCOMPLETE	TX_PKTLEN[14:8]						
0x15	I2C5[7:0]	TX_PKTLEN[7:0]							
0x16	I2C6[7:0]	UFLOW	OFLOW	FIFO_EMPTY	FIFO_FULL	–	FIFO_WORDS[2:0]		
0x17	CFG8[7:0]	–	–	–	–	–	–	SOFTRESET	
0x18	CFG9[7:0]	RESERVED[4:0]					RESERVED	RESERVED	RESERVED
0x19	ADDL1[7:0]	RESERVED[1:0]		RESERVED[1:0]		RESERVED[1:0]		RESERVED[1:0]	
0x1A	ADDL2[7:0]	RESERVED	RESERVED[6:0]						

Register Details

CFG1 (0x00)

BIT	7	6	5	4	3	2	1	0
Field	<u>XOCLKDELAY[1:0]</u>		<u>XOCLKDIV[1:0]</u>		–	<u>FSKSHAPE</u>	<u>SYNC</u>	<u>MODMODE</u>
Reset	0x2		0x1		–	0b0	0b0	0b0
Access Type	Write, Read		Write, Read		–	Write, Read	Write, Read	Write, Read

BITFIELD	BITS	DESCRIPTION	DECODE
XOCLKDELAY	7:6	Start delay before enabling XO clock to digital block	0x0: No delay. XO clock is immediately enabled to rest of digital block 0x1: XO clock is enabled after 16 cycles to rest of digital block 0x2: XO clock is enabled after 32 cycles to rest of digital block 0x3: XO clock is enabled after 64 cycles to rest of digital block
XOCLKDIV	5:4	XO clock division ratio for digital block	0x0: Divide XO clock by 4 for digital clock 0x1: Divide XO clock by 5 for digital clock. High time is 2 cycles, low time is 3 cycles 0x2: Divide XO clock by 6 for digital clock 0x3: Divide XO clock by 7 for digital clock. High time is 3 cycles, and low time is 4 cycles
FSKSHAPE	2	Sets the state of FSK Gaussain Shaping	0x0: FSK Shaping disabled 0x1: FSK Shaping enabled
SYNC	1	Controls if clock output acts as an input. When an input, it will sample the DATA pin.	0x0 0x1
MODMODE	0	Configures modulator mode	0x0: ASK Mode 0x1: FSK Mode

CFG2 (0x01)

BIT	7	6	5	4	3	2	1	0
Field	<u>CLKOUT_DELAY[1:0]</u>		–	–	–	<u>BCLK_POSTDIV[2:0]</u>		
Reset	0x2		–	–	–	0x1		
Access Type	Write, Read		–	–	–	Write, Read		

BITFIELD	BITS	DESCRIPTION	DECODE
CLKOUT_DELAY	7:6	Selects the delay when CLKOUT starts toggling upon exiting SHUTDOWN mode, in divided XO clock cycles	0x0: CLKOUT will start toggling after 64 cycles whenever moving into normal mode from shutdown mode 0x1: CLKOUT will start toggling after 128 cycles whenever moving into normal mode from shutdown mode 0x2: CLKOUT will start toggling after 256 cycles whenever moving into normal mode from shutdown mode

BITFIELD	BITS	DESCRIPTION	DECODE
			0x3: CLKOUT will start toggling after 512 cycles whenever moving into normal mode from shutdown mode
BCLK_POST DIV	2:0	Baud clock post-divider setting.	0x0: RESERVED 0x1: Divide by 1 0x2: Divide by 2 0x3: Divide by 3 0x4: Divide by 4 0x5: Divide by 5 0x6: RESERVED 0x7: RESERVED

CFG3 (0x02)

BIT	7	6	5	4	3	2	1	0
Field	BCLK_PREDIV[7:0]							
Reset	0x3							
Access Type	Write, Read							

BITFIELD	BITS	DESCRIPTION	DECODE
BCLK_PRED IV	7:0	Baud clock predivision ratio. Valid values are from 3 to 255.	0x00: RESERVED 0x01: RESERVED 0x02: RESERVED 0x03: Divide by 3 ... 0xFF: Divide by 255

CFG4 (0x03)

BIT	7	6	5	4	3	2	1	0
Field	–	–	–	–	–	–	PWDN_MODE[1:0]	
Reset	–	–	–	–	–	–	0x0	
Access Type	–	–	–	–	–	–	Write, Read	

BITFIELD	BITS	DESCRIPTION	DECODE
PWDN_MODE	1:0	Power Down Mode Select	0x0: SHUTDOWN low power state is enabled. While entering low power state, XO, PLL, and PA are shutdown. 0x1: STANDBY low power state is enabled. While entering low power state, XO is enabled. PLL and PA are shutdown 0x2: FAST WAKEUP low power state is enabled. While entering low power state, XO and PLL are enabled. PA is shutdown. 0x3: Will revert to 0x2

CFG5 (0x04)

BIT	7	6	5	4	3	2	1	0
Field	–	–	RESERVED[5:0]					
Reset	–	–	0x00					
Access Type	–	–	Write, Read					

BITFIELD	BITS	DESCRIPTION
RESERVED	5:0	Write to 00 hex.

SHDN (0x05)

BIT	7	6	5	4	3	2	1	0
Field	–	–	–	–	–	RESERVED	RESERVED	PA_BOOST
Reset	–	–	–	–	–	0x1	0x0	0x0
Access Type	–	–	–	–	–	Write, Read	Write, Read	Write, Read

BITFIELD	BITS	DESCRIPTION	DECODE
RESERVED	2	Write to 1 binary.	1
RESERVED	1	Write to 0 binary.	0
PA_BOOST	0	Enables a boost in PA output power for frequencies above 850MHz. This requires a different PA match compared to normal operation.	0x0: PA Output power in normal operation. 0x1: PA Output power in boost mode for more output power.

PA1 (0x06)

BIT	7	6	5	4	3	2	1	0
Field	RESERVED[2:0]			–	–	PAPWR[2:0]		
Reset	0x4			–	–	0x0		
Access Type	Write, Read			–	–	Write, Read		

BITFIELD	BITS	DESCRIPTION	DECODE
RESERVED	7:5	Write to 100 binary.	100
PAPWR	2:0	Controls the PA output power by enabling parallel drivers.	0x0: Minimum, 1 driver 0x1: 2 Drivers 0x2: 3 Drivers 0x3: 4 Drivers 0x4: 5 Drivers 0x5: 6 Drivers 0x6: 7 Drivers 0x7: 8 Drivers

PA2 (0x07)

BIT	7	6	5	4	3	2	1	0
Field	–	–	–	PACAP[4:0]				
Reset	–	–	–	0x0				
Access Type	–	–	–	Write, Read				

BITFIELD	BITS	DESCRIPTION	DECODE
PACAP	4:0	Controls shunt capacitance on PA output in fF.	0x00: 0 0x01: 175 0x02: 350 0x03: 525 0x04: 700 0x05: 875 0x06: 1050 0x07: 1225 0x08: 1400 0x09: 1575 0x0A: 1750 0x0B: 1925 0x0C: 2100 0x0D: 2275 0x0E: 2450 0x0F: 2625 0x10: 2800 0x11: 2975 0x12: 3150 0x13: 3325 0x14: 3500 0x15: 3675 0x16: 3850 0x17: 4025 0x18: 4200 0x19: 4375 0x1A: 4550 0x1B: 4725 0x1C: 4900 0x1D: 5075 0x1E: 5250 0x1F: 5425

PLL1 (0x08)

BIT	7	6	5	4	3	2	1	0
Field	CPLIN[1:0]		FRACMODE	RESERVED[1:0]		LODIV[1:0]		LOMODE
Reset	0x1		0x1	0x00		0x0		0b0
Access Type	Write, Read		Write, Read	Write, Read		Write, Read		Write, Read

BITFIELD	BITS	DESCRIPTION	DECODE
CPLIN	7:6	Sets the level of charge pump offset current for fractional N mode to improve close in phase noise. Set to 'DISABLED' for integer N	0x0: No extra current 0x1: 5% of charge pump current 0x2: 10% of charge pump current

BITFIELD	BITS	DESCRIPTION	DECODE
		mode.	0x3: 15% of charge pump current
FRACMODE	5	Sets PLL between fractional-N and integer-N mode.	0x0: Integer N Mode 0x1: Fractional N Mode
RESERVED	4:3	Write to 00 binary.	00
LODIV	2:1		0x0: Disabled 0x1: LC VCO divided by 4 0x2: LC VCO divided by 8 0x3: LC VCO divided by 12
LOMODE	0	Sets LO generation. For lower power, choose LOWCURRENT. For higher performance, choose LOWNOISE.	0x0: Ring Oscillator Mode 0x1: LC VCO Mode

PLL2 (0x09)

BIT	7	6	5	4	3	2	1	0
Field	RESERVED	RESERVED	–	–	–	–	CPVAL[1:0]	
Reset	0x0	0b0	–	–	–	–	0x0	
Access Type	Write, Read	Write, Read	–	–	–	–	Write, Read	

BITFIELD	BITS	DESCRIPTION	DECODE
RESERVED	7	Write to 0 binary.	0
RESERVED	6	Write to 0 binary.	0
CPVAL	1:0	Sets Charge Pump Current	0x0: 5µA 0x1: 10µA 0x2: 15µA 0x3: 20µA

CFG6 (0x0A)

BIT	7	6	5	4	3	2	1	0
Field	–	–	–	–	–	I2C_TXEN1	RESERVED	RESERVED
Reset	–	–	–	–	–	0x0	0x0	0x0
Access Type	–	–	–	–	–	Write, Read	Write, Read	Write, Read

BITFIELD	BITS	DESCRIPTION	DECODE
I2C_TXEN1	2	Enables DATA transmission in I ² C mode. Aliased address for I2C_TXEN1.	0x0: Data transmission not enabled in I ² C mode. 0x1: Data transmission enabled in I ² C mode.
RESERVED	1	Write to 0 binary.	
RESERVED	0	Write to 0 binary.	

PLL3 (0x0B)

BIT	7	6	5	4	3	2	1	0
Field	FREQ[23:16]							
Reset	0x13							
Access Type	Write, Read							

BITFIELD	BITS	DESCRIPTION
FREQ	7:0	FREQ value to PLL. LO frequency= FREQ<23:0>/2 ¹⁶ *fXTAL

PLL4 (0x0C)

BIT	7	6	5	4	3	2	1	0
Field	FREQ[15:8]							
Reset	0xB0							
Access Type	Write, Read							

BITFIELD	BITS	DESCRIPTION
FREQ	7:0	FREQ value to PLL

PLL5 (0x0D)

BIT	7	6	5	4	3	2	1	0
Field	FREQ[7:0]							
Reset	0x00							
Access Type	Write, Read							

BITFIELD	BITS	DESCRIPTION
FREQ	7:0	FREQ value to PLL

PLL6 (0x0E)

BIT	7	6	5	4	3	2	1	0
Field	–	DELTA[6:0]						
Reset	–	0x28						
Access Type	–	Write, Read						

BITFIELD	BITS	DESCRIPTION
DELTA	6:0	For FSK mode, MODMODE=1 and FSKSHAPE=0, sets the frequency deviation from the space frequency for the mark frequency. fDELTA = DELTA[6:0] * fXTAL / 8192

PLL7 (0x0F)

BIT	7	6	5	4	3	2	1	0
Field	–	–	–	–	DELTA_SHAPE[3:0]			
Reset	–	–	–	–	0x4			
Access Type	–	–	–	–	Write, Read			

BITFIELD	BITS	DESCRIPTION
DELTA_SHAPE	3:0	For FSK mode, MODMODE = 1 and FSKSHAPE = 1, sets the frequency deviation from the space frequency for the mark frequency. $f_{DELTA} = DELTA_SHAPE[3:0] * f_{XTAL} / 81920$

CFG7 (0x10)

BIT	7	6	5	4	3	2	1	0
Field	–	–	–	–	–	I2C_TXEN2	RESERVED	RESERVED
Reset	–	–	–	–	–	0x0	0x0	0x0
Access Type	–	–	–	–	–	Write, Read	Write, Read	Write, Read

BITFIELD	BITS	DESCRIPTION	DECODE
I2C_TXEN2	2	Enables DATA transmission in I ² C mode. Aliased address for I2C_TXEN1	0x0: Data transmission not enabled in I ² C mode. 0x1: Data transmission enabled in I ² C mode.
RESERVED	1		
RESERVED	0	Write to 0 binary.	

I2C1 (0x11)

BIT	7	6	5	4	3	2	1	0
Field	PKTLEN_MODE	PKTLEN[14:8]						
Reset	0x0	0x0						
Access Type	Write, Read	Write, Read						

BITFIELD	BITS	DESCRIPTION	DECODE
PKTLEN_MODE	7	Packet Length Mode	0x0: PKTLEN[14:0] need not be programmed. FIFO underflow event will be treated as end of packet event. For cases where actual packet length is greater than 32767 bits, it is expected that the μ C will pad such a packet to make it an integral multiple of 8-bits 0x1: PKTLEN[14:0] will provide the length of packet. Once FIFO is read for PKTLEN[14:0] bits, or if FIFO underflow, MAX4146x will consider that as an end of packet event.
PKTLEN	6:0	Packet Length	

I²C2 (0x12)

BIT	7	6	5	4	3	2	1	0
Field	PKTLEN[7:0]							
Reset	0xFF							
Access Type	Write, Read							

BITFIELD	BITS	DESCRIPTION
PKTLEN	7:0	Packet Length

I²C3 (0x13)

BIT	7	6	5	4	3	2	1	0
Field	I²C_TX_DATA[7:0]							
Reset	0x0							
Access Type	Write, Read							

BITFIELD	BITS	DESCRIPTION
I ² C_TX_DATA	7:0	Transmit data to be written into FIFO for I ² C mode of operation. At this address, I ² C register address will not auto increment within an I ² C transaction burst, and subsequent writes will keep going to FIFO

I²C4 (0x14)

BIT	7	6	5	4	3	2	1	0
Field	PKTCOMPL ETE	TX_PKTLEN[14:8]						
Reset	0x0	0x0						
Access Type	Read Only	Read Only						

BITFIELD	BITS	DESCRIPTION	DECODE
PKTCOMPL ETE	7	Indicates if Packet transmission is completed	0x0: Packet transmission is not completed 0x1: Packet transmission is completed
TX_PKTLEN	6:0	Provides status information of bits transmitted for the current packet	

I²C5 (0x15)

BIT	7	6	5	4	3	2	1	0
Field	TX_PKTLEN[7:0]							
Reset	0x0							
Access Type	Read Only							

BITFIELD	BITS	DESCRIPTION
TX_PKTLEN	7:0	Provides status information of bits transmitted for the current packet

I2C6 (0x16)

BIT	7	6	5	4	3	2	1	0
Field	UFLOW	OFLOW	FIFO_EMPTY	FIFO_FULL	–	FIFO_WORDS[2:0]		
Reset	0x0	0x0	0x1	0x0	–	0x0		
Access Type	Read Only	Read Only	Read Only	Read Only	–	Read Only		

BITFIELD	BITS	DESCRIPTION
UFLOW	7	FIFO Underflow status
OFLOW	6	FIFO Overflow status
FIFO_EMPTY	5	FIFO Empty Status
FIFO_FULL	4	FIFO Full Status
FIFO_WORDS	2:0	This field captures the number of locations currently filled in FIFO. Each location corresponds to 8-bit data word

CFG8 (0x17)

BIT	7	6	5	4	3	2	1	0
Field	–	–	–	–	–	–	–	SOFTRESET
Reset	–	–	–	–	–	–	–	0b0
Access Type	–	–	–	–	–	–	–	Write, Read

BITFIELD	BITS	DESCRIPTION	DECODE
SOFTRESET	0	Places DUT into software reset.	0x0: Deassert the reset 0x1: Resets the entire digital, until this bit is set to 0

CFG9 (0x18)

BIT	7	6	5	4	3	2	1	0
Field	RESERVED[4:0]					RESERVED	RESERVED	RESERVED
Reset	0x0					0x0	0x0	0x0
Access Type	Write, Read					Write, Read	Write, Read	Write, Read

BITFIELD	BITS	DESCRIPTION	DECODE
RESERVED	7:3	Write to 0_0000 binary.	00000
RESERVED	2	Write to 0 binary.	0
RESERVED	1	Write to 0 binary.	0
RESERVED	0	Write to 0 binary.	0

ADDL1 (0x19)

BIT	7	6	5	4	3	2	1	0
Field	RESERVED[1:0]		RESERVED[1:0]		RESERVED[1:0]		RESERVED[1:0]	
Reset	0x0		0x0		0x0		0x0	
Access Type	Write, Read		Write, Read		Write, Read		Write, Read	

BITFIELD	BITS	DESCRIPTION	DECODE
RESERVED	7:6	Write to 00 binary.	00
RESERVED	5:4	Write to 00 binary.	00
RESERVED	3:2	Write to 00 binary.	00
RESERVED	1:0	Write to 00 binary.	00

ADDL2 (0x1A)

BIT	7	6	5	4	3	2	1	0
Field	RESERVED	RESERVED[6:0]						
Reset	0x1	0x0						
Access Type	Write, Read	Write, Read						

BITFIELD	BITS	DESCRIPTION	DECODE
RESERVED	7	Write to 1 binary.	1
RESERVED	6:0	Write to 000_0000 binary.	0000000

Applications Information

Power-On Programming

Preset Mode

To ensure the MAX41461/MAX41462 device enters shutdown state after power-on, the DATA pin must be held low at power-on. If the DATA pin cannot be guaranteed low at power-on, then a high-value pulldown resistor is recommended. After V_{DD} has settled, a logic-low-high-low transition on DATA must occur in the preset mode. If the pulse duration of low-high-low transition is longer than t_{XO} + t_{PLL}, it is a valid wake-up pulse before data transmission. It is also allowed to have a short pulse duration between 5μs and 20μs. The short pulse will not wake up the device.

Programming Mode

After turning on power supply in I²C mode, a logic-high-low-high transition on SDA must occur to minimize leakage current in shutdown state. It is highly recommended that the I²C resistors are connected to the MAX41461/MAX41462 V_{DD}.

Two I²C transactions are required to initialize the PLL frequency synthesizer. The first transaction ensures register ADDL2 at address 0x1A is written to its default of 0x80. The second transaction burst-writes 20 consecutive registers from address 0x00 to 0x13. The device is programmed to transmit a dummy packet with 8 zero bits in ASK mode. There is no RF emission at PA output. See [Initial Programming](#) section.

For example, the crystal frequency is 16MHz, the RF frequency is 315MHz, the 20 consecutive registers from address 0x00 to 0x13 can be configured as:

[0x90, 0x81, 0x03, 0x00, 0x00, 0x04, 0x80, 0x80, 0x60, 0x00, 0x00, 0xC4, 0xDE, 0x98, 0x28, 0x04, 0x04, 0x00, 0xFF, 0x00]

After initial programming, the device will enter the shutdown, standby, or programming state according to the setting of PWDN_MODE[1:0] (register CFG4, address 0x03, bit[1:0]). Configuration register values are retained in all states unless changed by programming, or if the device is powered off or undergoes a SOFTRESET. See [Startup](#) section for directions to program the device for data transmission.

ASK Carrier Frequency

The ASK carrier frequency is set by the FREQ bits in registers 0x0B, 0x0C, and 0x0D. The user calculates the divide ratio based on the carrier frequency and crystal frequency. The following equation shows how to determine the correct value to be loaded into the FREQ registers.

$$FREQ = \left(\frac{f_{RF}}{f_{XTAL}} \right) \times 65536$$

For example, the desired ASK transmit frequency is 315MHz and the crystal frequency is 16MHz. 315/16 is 19.6875. 19.6875 x 65536 is 1290240. Converted into hex, the value is 0x13B000. This value is loaded into FREQ[23:0]. In the case where the value is non-integer, the value may be rounded to the nearest integer.

Tuning Capacitor Settings

The internal variable shunt capacitor, which can be used to match the PA to the antenna with changing transmitter frequency, is controlled by setting the 5-bit cap variable in the registers. This allows for 32 levels of shunt capacitance control. Since the control of these 5 bits is independent of the other settings, any capacitance value can be chosen at any frequency, making it possible to maintain maximum transmitter efficiency while moving rapidly from one frequency to another. The internal tuning capacitor adds 0 to 5.425pF to the PA output in 0.175pF steps.

Crystal Frequency Selection

In order to avoid integer boundary spurs in fractional-N PLL synthesizers, the crystal should be selected so that the RF carrier frequency is more than 0.4MHz apart from the nearest integer multiple of crystal frequency.

For example, the 16±0.002MHz crystals can be selected for the 433.92MHz RF carrier, which is more than 0.4MHz apart from the nearest integer multiple of crystal frequency at 432±0.054MHz. However, the 16±0.002MHz crystals are not suitable for a RF carrier at 912MHz or 928MHz.

In the programming mode, the crystal divider ratio is programmable. The crystal divider ratio should be configured so that the divided clock frequency is 3.2±0.1MHz. In addition, the PLL synthesizer requires a reference frequency (same as crystal frequency) between 12.8MHz and 19.2MHz. Therefore, when crystal divider ratio is 4, 5, or 6, allowed range of crystal frequency is 12.8MHz~13.2MHz, 15.5MHz~16.5MHz, or 18.6MHz~19.2MHz.

In another example, desired RF frequencies are 319.5MHz, 345.0MHz, and 433.92MHz, and recommended crystal selection is 13±0.002MHz so that integer boundary spurs are completely suppressed for three desired RF frequencies. Nevertheless, the 16±0.002MHz and 19.2±0.002MHz crystals are also acceptable.

In the preset mode, the crystal divider ratio is preset at 5. When the RF carrier frequency is very close to an integer multiple of 16MHz, the crystal selection can change to 16.384MHz or 16.128MHz, and the RF carrier frequency should be preset through OTP memory in production.

Typical Application Circuit

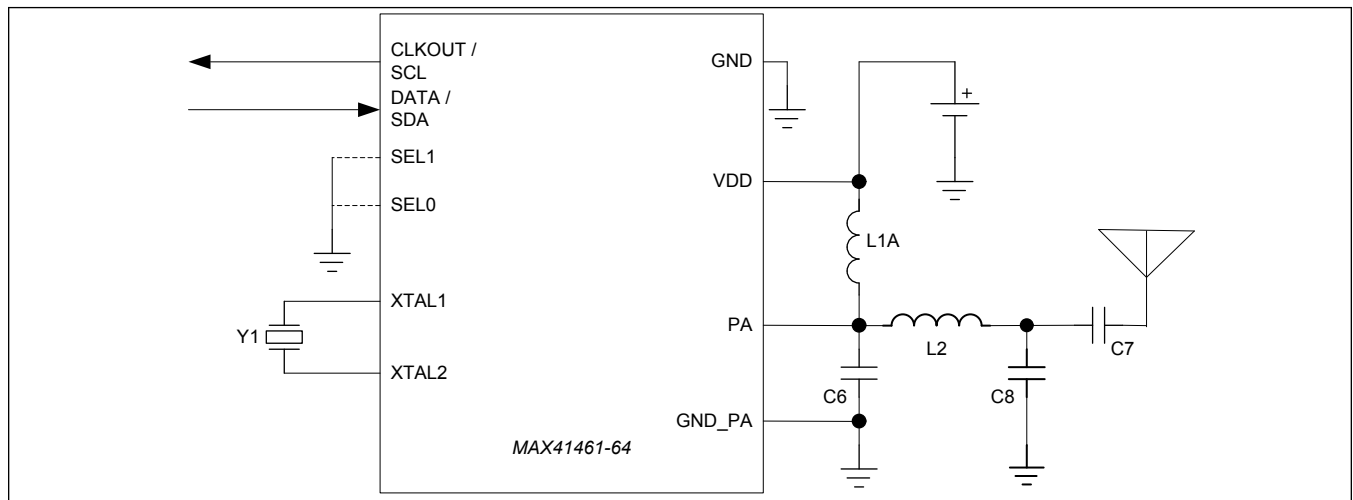

Ordering Information

PART NUMBER	TEMPERATURE RANGE	PIN-PACKAGE
MAX41461GUB+	-40°C to +105°C	10 μMAX
MAX41461GUB+T	-40°C to +105°C	10 μMAX
MAX41462GUB+	-40°C to +105°C	10 μMAX
MAX41462GUB+T	-40°C to +105°C	10 μMAX

+Denotes a lead(Pb)-free/RoHS-compliant package.

T = Tape-and-reel.

Revision History

REVISION NUMBER	REVISION DATE	DESCRIPTION	PAGES CHANGED
0	10/18	Initial release	—
1	3/19	Updated TSSOP references to μ MAX	1, 2, 9, 11, 38

For pricing, delivery, and ordering information, please visit Maxim Integrated's online storefront at <https://www.maximintegrated.com/en/storefront/storefront.html>.

Maxim Integrated cannot assume responsibility for use of any circuitry other than circuitry entirely embodied in a Maxim Integrated product. No circuit patent licenses are implied. Maxim Integrated reserves the right to change the circuitry and specifications without notice at any time. The parametric values (min and max limits) shown in the Electrical Characteristics table are guaranteed. Other parametric values quoted in this data sheet are provided for guidance.

X-ON Electronics

Largest Supplier of Electrical and Electronic Components

Click to view similar products for [RF Transmitter](#) category:

Click to view products by [Maxim](#) manufacturer:

Other Similar products are found below :

[AX5031-1-TW30](#) [TDK5100FHTMA1](#) [MICRF405YML-TR](#) [MICRF112YMM-TR](#) [SI4063-C2A-GM](#) [ADF5901WCCPZ](#) [ADF5901ACPZ](#)
[ADF5902WCCPZ](#) [HMC6300BG46](#) [HMC8200LP5ME](#) [SX1243IULTRT](#) [TDA7100HTMA1](#) [MICRF114T-I/OT](#) [MAX1479ATE+](#)
[MAX2902ETI+](#) [MAX2903ETI+](#) [MAX41464GUB+](#) [MAX7044AKA+T](#) [MAX1472AKA+T](#) [MICRF113YM6 TR](#) [MAQRF112YMM](#)
[MICRF102YM](#) [MICRF112YMM](#) [CMX998Q1](#) [SI4063-B1B-FM](#) [TDA7110FHTMA1](#) [CC1150RGVR](#) [TL851CDR](#) [ATA8402C-6AQY-66](#)
[MAX7057ASE+](#) [SQUIDBOARD-868](#) [HORNETPRO-8S1](#) [HORNETPRO-8S3](#) [ATA5757C-6DQY-66](#) [AFE7070IRGZT](#) [AFE7071IRGZT](#)
[CC115LRGPT](#) [CC2550RSTR](#) [TL851CD](#) [TL851CN](#) [TL851CNE4](#)