

## General Description

The MAX44246 evaluation kit (EV kit) provides a proven design to evaluate the MAX44246 ultra-precision, low-noise, low-drift dual-operational amplifiers (op amps) in an 8-pin  $\mu$ MAX<sup>®</sup> package. The EV kit circuit is preconfigured as noninverting amplifiers, but can be adapted to other topologies by changing a few components.

The EV kit comes with a MAX44246AUA+ installed.

## Features

- Accommodates Multiple Op-Amp Configurations
- Component Pads Allow for Sallen-Key Filter
- Accommodates Easy-to-Use Components
- Proven PCB Layout
- Fully Assembled and Tested

[Ordering Information](#) appears at end of data sheet.

## Component List

DESIGNATION	QTY	DESCRIPTION
C1, C17	2	0.1 $\mu$ F $\pm$ 10%, 50V X7R ceramic capacitors (0603) Murata GRM21BR71H104K
C2, C18	2	4.7 $\mu$ F $\pm$ 10%, 50V X7R ceramic capacitors (1206) Murata GRM31CR71H475K
C3–C16	0	Not installed, ceramic capacitors (0603) C3, C6, C7, C8, C10, C13–C15 are open; C4, C5, C9, C11, C12, C16 are short (PC trace)
INMA, INMB, INPA, INPB, OUTA, OUTB	6	Red multipurpose test points
JU1–JU5	5	2-pin headers

DESIGNATION	QTY	DESCRIPTION
R1, R2, R9, R10	4	1k $\Omega$ $\pm$ 1% resistors (0603)
R3, R4, R7, R11, R12, R15	0	Not installed, resistors (0603)
R5, R13	2	10k $\Omega$ $\pm$ 1% resistors (0603)
R6, R8, R14, R16	4	0 $\Omega$ $\pm$ 5% resistors (0603)
TP1, TP2	0	Not installed, miniature test points
U1	1	Low-noise, precision, dual op amp (8 $\mu$ MAX) Maxim MAX44246AUA+
—	5	Shunts
—	1	PCB: MAX44246 EVALUATION KIT

## Component Supplier

SUPPLIER	PHONE	WEBSITE
Murata Electronics North America Inc.	770-436-1300	www.murata-northamerica.com

**Note:** Indicate that you are using the MAX44246 when contacting this component supplier.

$\mu$ MAX is a registered trademark of Maxim Integrated Products, Inc.



## Quick Start

### Required Equipment

- MAX44246 EV kit
- +36V, 10mA DC power supply (PS1)
- Two precision voltage sources
- Two digital multimeters (DMMs)

### Procedure

The EV kit is fully assembled and tested. Follow the steps below to verify board operation:

- 1) Verify that all jumpers (JU1–JU5) are in their default positions, as shown in Table 1.
- 2) Connect the positive terminal of the +36V supply to VCC and the negative terminal to GND and VEE.
- 3) Connect the positive terminal of the precision voltage source to INPA. Connect the negative terminal of the precision voltage source to GND. INMA is already connected to GND through jumper JU1.
- 4) Connect the positive terminal of the second precision voltage source to the INPB PCB pad. Connect the negative terminal of the precision voltage source to GND. INMB is already connected to GND through jumper JU3.
- 5) Connect the DMMs to monitor the voltages on OUTA and OUTB. With the 10kΩ feedback resistors and 1kΩ series resistors, the gain of each noninverting amplifier is +11.
- 6) Turn on the +36V power supply.
- 7) Apply 100mV from the precision voltage sources. Observe the output at OUTA and OUTB on the DMMs. Both should read approximately +1.1V.
- 8) Apply 400mV from the precision voltage sources. Both OUTA and OUTB should read approximately +4.4V.

**Note:** For dual-supply operation, a ±2.7V to ±18V can be applied to VDD and VEE, respectively. In this case, remove the shunt on jumper JU5. The rest of the procedure remains the same as that of the single-supply operation.

## Detailed Description of Hardware

The MAX44246 EV kit provides a proven layout for the MAX44246 ultra-precision, low-noise, low-drift, dual op amp. The device is a single/dual-supply, dual op amp (op amp A and op amp B) that is ideal for ADC buffers.

The default configuration for the device in the EV kit is single-supply operation in noninverting configuration. However, the device can operate with a dual supply as long as the voltage across the VDD and GND pins of the IC do not exceed the absolute maximum ratings. When

operating with a single supply, short VEE to GND using jumper JU5.

### Op-Amp Configurations

The device is a single/dual-supply dual op amp that is ideal for differential sensing, noninverting amplification, buffering, and filtering. A few common configurations are shown in the next few sections.

The following sections explain how to configure one of the device's op amps (op amp A). To configure the device's second op amp (op amp B), the same equations can be used after modifying the component reference designators.

#### Noninverting Configuration

The EV kit comes preconfigured as a noninverting amplifier. The gain is set by the ratio of R5 and R1. The EV kit comes preconfigured for a gain of +11. The output voltage for the noninverting configuration is given by the equation below:

$$V_{OUTA} = \left(1 + \frac{R5}{R1}\right) [V_{INPA} \pm V_{OS}]$$

#### Inverting Configuration

To configure the EV kit as an inverting amplifier, remove the shunt on jumper JU1 and install a shunt on jumper JU2 and feed an input signal on the INMA PCB pad.

#### Differential Amplifier

To configure the EV kit as a differential amplifier, replace R1–R3 and R5 with appropriate resistors. When R1 = R2 and R3 = R5, the CMRR of the differential amplifier is determined by the matching of the resistor ratios R1/R2 and R3/R5.

$$V_{OUTA} = \text{GAIN}(V_{INPA} - V_{INMA})$$

where:

$$\text{GAIN} = \frac{R5}{R1} = \frac{R3}{R2}$$

#### Sallen-Key Configuration

The Sallen-Key topology is ideal for filtering sensor signals with a second-order filter and acting as a buffer. Schematic complexity is reduced by combining the filter and buffer operations. The EV kit can be configured in a Sallen-Key topology by replacing and populating a few components. The Sallen-Key topology can be configured as a unity-gain buffer by replacing R5 with 0Ω resistor and removing resistor R1. The signal is noninverting and applied to INPA. The filter component pads are R2–R4 and R8, where some have to be populated with resistors and others with capacitors.

**Lowpass Sallen-Key Filter:** To configure the Sallen-Key as a lowpass filter, remove the shunt from jumper JU1, populate the R2 and R8 pads with resistors, and populate the R3 and R4 pads with capacitors. The corner frequency and Q are then given by:

$$f_C = \frac{1}{2\pi\sqrt{R_{R2}R_{R8}C_{R3}C_{R4}}}$$

$$Q = \frac{\sqrt{R_{R2}R_{R8}C_{R3}C_{R4}}}{C_{R3}(R_{R2} + R_{R8})}$$

**Highpass Sallen-Key Filter:** To configure the Sallen-Key as a highpass filter, remove the shunt from jumper JU1, populate the R3 and R4 pads with resistors, and populate the R2 and R8 pads with capacitors. The corner frequency and Q are then given by:

$$f_C = \frac{1}{2\pi\sqrt{R_{R3}R_{R4}C_{R2}C_{R8}}}$$

$$Q = \frac{\sqrt{R_{R3}R_{R4}C_{R2}C_{R8}}}{R_{R4}(C_{R2} + C_{R8})}$$

**Bandpass Sallen-Key Filter:** To configure the Sallen-Key as a bandpass filter, remove the shunt from jumper JU1, replace R8, populate the R3 and R4 pads with resistors, and populate the C8 and R2 pads with capacitors. The corner frequency and Q are then given by:

$$f_C = \frac{1}{2\pi\sqrt{C_{C8}C_{R2}R_{R8}R_{R3}R_{R4}}}$$

$$Q = \frac{\sqrt{(R_{R4} + R_{R8})C_{C8}C_{R2}R_{R8}R_{R3}R_{R4}}}{R_{R4}R_{R8}(C_{C8} + C_{R2}) + R_{R3}C_{R2}(R_{R4} - \frac{R_{R5}R_{R8}}{R_{R1}})}$$

**Transimpedance Amplifier (TIA)**

To configure the MAX44246 EV kit as a TIA, place a shunt on jumper JU2 and replace R1 and R2 with 0Ω resistors. The output voltage of the TIA is the input current multiplied by the feedback resistor:

$$V_{OUT} = (I_{IN} + I_{BIAS}) \times R_{R5} \pm V_{OS}$$

where

$I_{IN}$  is the input current source applied at the INPA test point

$I_{BIAS}$  is the input bias current

$V_{OS}$  is the input offset voltage of the op amp

Use capacitor C7 (and C8, if applicable) to stabilize the op amp by rolling off high-frequency gain due to a large cable capacitance.

**Capacitive Loads**

Some applications require driving large capacitive loads. The EV kit provides C8 and R6 pads for optional capacitive-load driving circuit. C8 simulates the capacitive load while R6 acts as an isolation resistor to improve the op-amp’s stability at higher capacitive loads. To improve the stability of the amplifier in such cases, replace R6 with a suitable resistor value to improve amplifier phase margin.

**Table 1. Jumper Descriptions (JU1–JU5)**

JUMPER	SHUNT POSITION	DESCRIPTION
JU1	Pin 1	Disconnects INMA from GND.
	1-2*	Connects INA- to GND through R1 for noninverting configuration.
JU2	Pin 1*	Disconnects INPA from GND.
	1-2	Connects INA+ to GND through R2.
JU3	Pin 1	Disconnects INMB from GND.
	1-2*	Connects INB- to GND through R9 for noninverting configuration.
JU4	Pin 1*	Disconnects INPB from GND.
	1-2	Connects INB+ to GND through R10.
JU5	Pin 1	VEE and GND are independently supplied for dual-supply operation.
	1-2*	Connects VEE to GND for single-supply operation.

\*Default position.

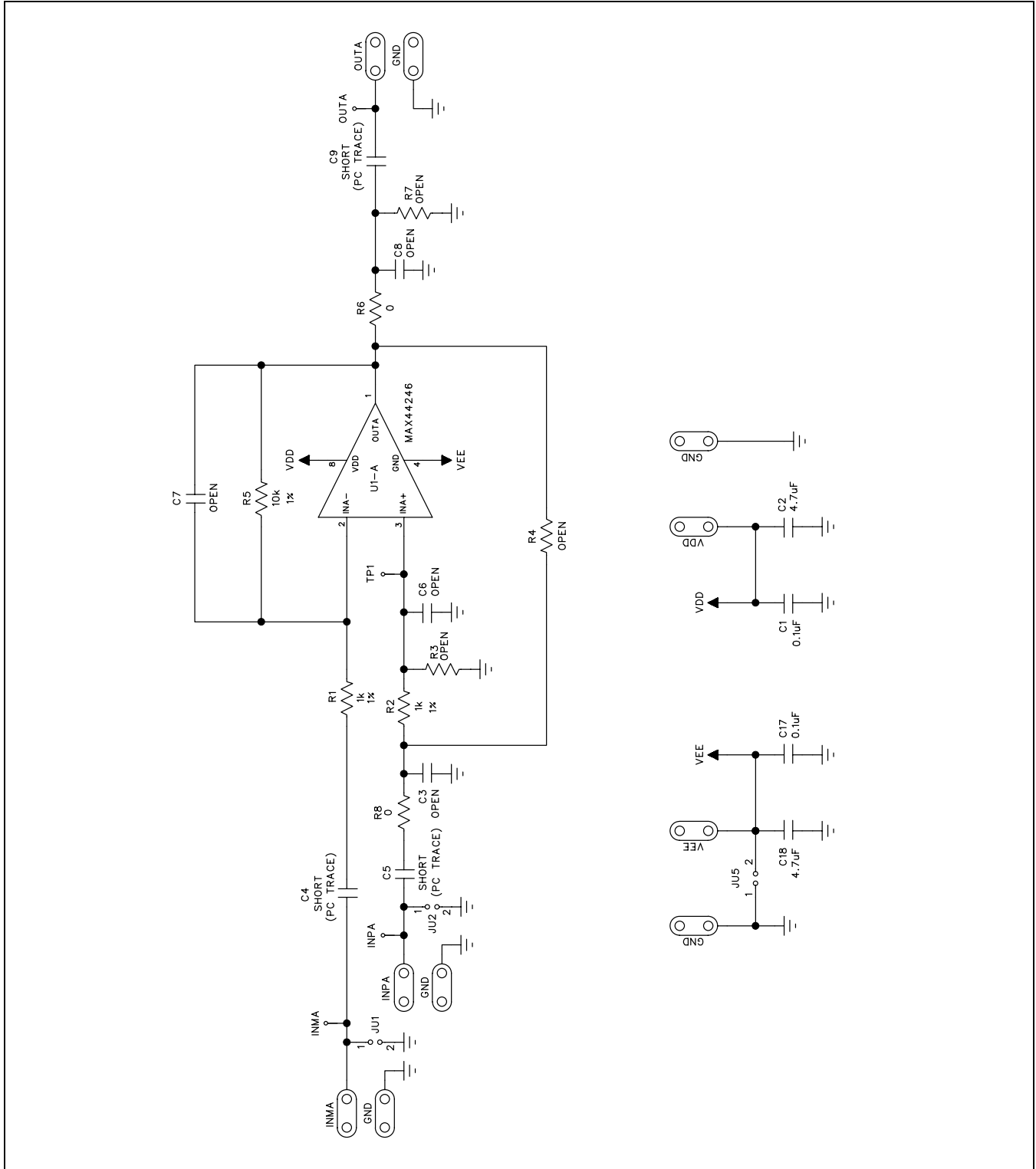

Figure 1a. MAX44246 EV Kit Schematic (Sheet 1 of 2)

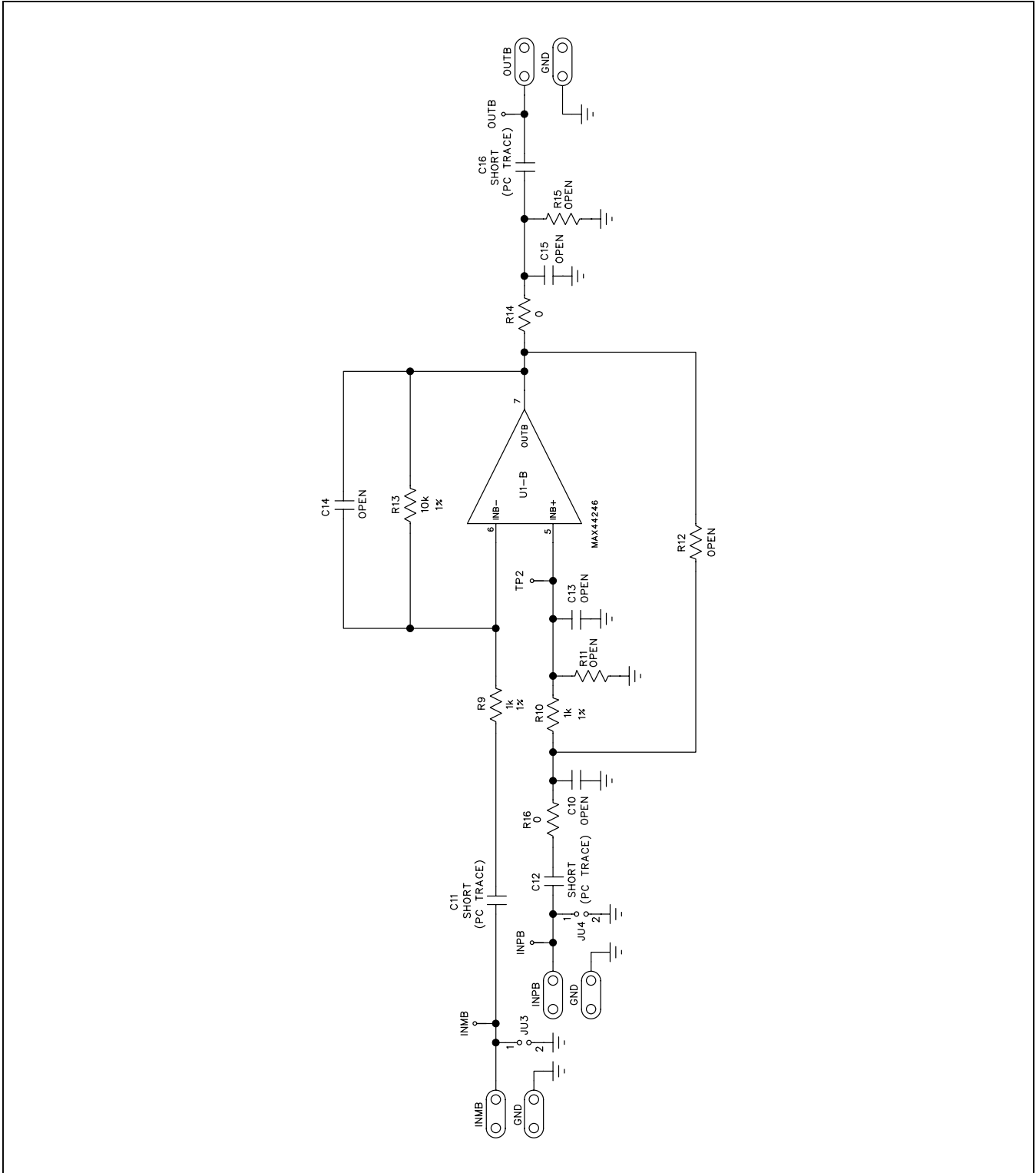

Figure 1b. MAX44246 EV Kit Schematic (Sheet 2 of 2)

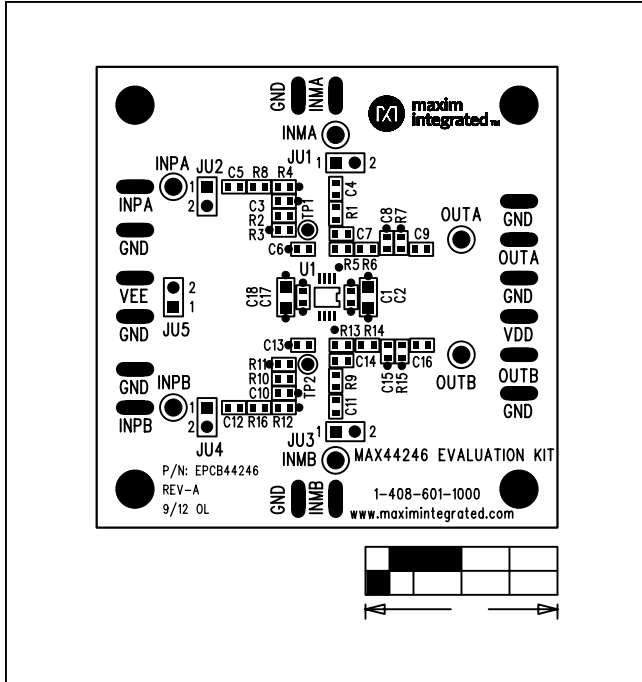

Figure 2. MAX44246 EV Kit Component Placement Guide—Component Side

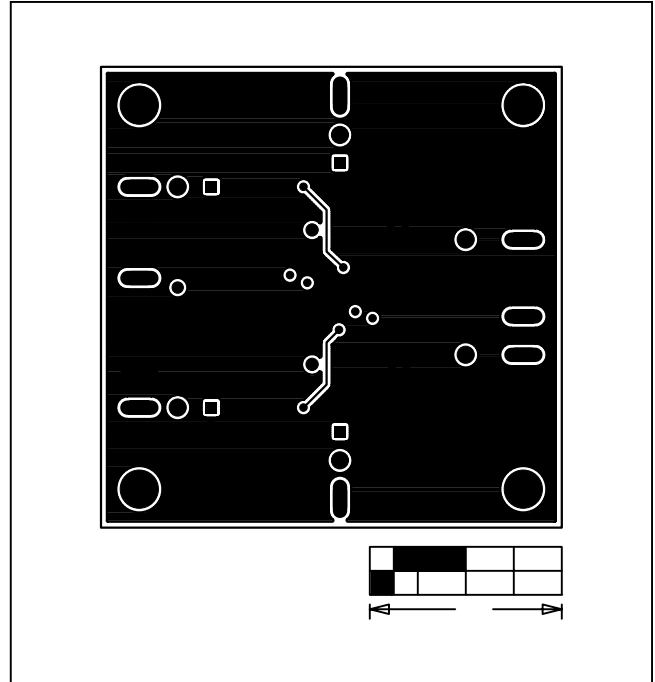

Figure 4. MAX44246 EV Kit PCB Layout—Solder Side

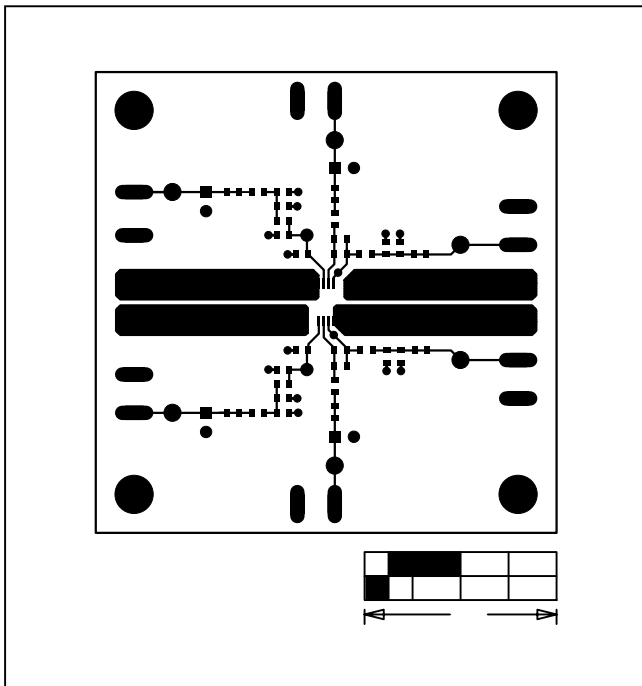

Figure 3. MAX44246 EV Kit PCB Layout—Component Side

### Ordering Information

PART	TYPE
MAX44246EVKIT#	EV Kit

*#Denotes RoHS compliant.*

## Revision History

REVISION NUMBER	REVISION DATE	DESCRIPTION	PAGES CHANGED
0	12/12	Initial release	—

For pricing, delivery, and ordering information, please contact Maxim Direct at 1-888-629-4642, or visit Maxim's website at [www.maximintegrated.com](http://www.maximintegrated.com).

*Maxim Integrated cannot assume responsibility for use of any circuitry other than circuitry entirely embodied in a Maxim Integrated product. No circuit patent licenses are implied. Maxim Integrated reserves the right to change the circuitry and specifications without notice at any time. The parametric values (min and max limits) shown in the Electrical Characteristics table are guaranteed. Other parametric values quoted in this data sheet are provided for guidance.*



## X-ON Electronics

Largest Supplier of Electrical and Electronic Components

*Click to view similar products for [Amplifier IC Development Tools](#) category:*

*Click to view products by [Maxim](#) manufacturer:*

Other Similar products are found below :

[AD8033AKS-EBZ](#) [AD8044AR-EBZ](#) [AD744JR-EBZ](#) [AD8023AR-EBZ](#) [AD848JR-EBZ](#) [ADA4922-1ACP-EBZ](#) [EVAL-ADCMP553BRMZ](#)  
[EVAL-ADCMP608BKSZ](#) [MIOP 42109](#) [EVAL-ADCMP609BRMZ](#) [ADA4950-1YCP-EBZ](#) [MAX2634EVKIT](#) [ISL28158EVAL1Z](#) [MADL-](#)  
[011014-001SMB](#) [AD8137YCP-EBZ](#) [EVAL-ADA4523-1ARMZ](#) [EVAL01-HMC1013LP4E](#) [MCP6XXXEV-AMP3](#) [MCP6XXXEV-AMP4](#)  
[MCP6XXXEV-AMP2](#) [ISL28006FH-100EVAL1Z](#) [551012922-001/NOPB](#) [EVAL-ADCMP603BCPZ](#) [AMC1200EVM](#) [AD8417RM-EVALZ](#)  
[DEM-OPA-SOT-1A](#) [DEM-OPA-SO-1C](#) [DEM-BUF-SOT-1A](#) [OPA2836IDGSEVM](#) [AD633-EVALZ](#) [AD8418R-EVALZ](#)  
[ISL28433SOICEVAL1Z](#) [ISL28233SOICEVAL1Z](#) [ISL28208SOICEVAL2Z](#) [ISL28207SOICEVAL2Z](#) [ISL28006FH-50EVAL1Z](#)  
[ISL28005FH-50EVAL1Z](#) [120257-HMC613LC4B](#) [DC1591A](#) [DC1150A](#) [DC1115A](#) [DC954A-C](#) [DC306A-A](#) [DC1192A](#) [131679-](#)  
[HMC813LC4B](#) [OPA2835IDGSEVM](#) [LMH730220/NOPB](#) [MAAP-011246-1SMB](#) [118329-HMC627ALP5](#) [125932-HMC874LC3C](#)