

General Description

The MAX44286 evaluation kit (EV kit) provides a proven design to evaluate the MAX44286 zero-drift, high-side, current-sense amplifier that offers precision and low supply current. This EV kit demonstrates the MAX44286 in an ultra-small, 0.78mm x 0.78mm x 0.35mm, 4-bump wafer-level package (WLP).

The EV kit PCB comes with a MAX44286FAZS+ installed, which is the 50V/V gain version. Other gain options are available. Contact the factory for free samples of the pin-compatible MAX44286TAZS+ (25V/V gain), MAX44286HAZS+ (100V/V gain), and MAX44286WAZS+ (200V/V gain).

EV Kit Contents

- MAX44286 EV Kit Board

Features and Benefits

- Precision Real-Time Current Monitoring
- +1.8V to +5.5V Input Common-Mode Range
- Proven PCB Layout
- RoHS Compliant

[Ordering Information](#) appears at end of data sheet.

Quick Start

Required Equipment

The following items are required for operation:

- MAX44286 EV kit
- +3.3V, 1.5A DC power supply
- Electronic load capable of sinking 1A (i.e., HP6060B)
- Two digital voltmeters (DVMs)

Procedure

The EV kit is fully assembled and tested. Follow the steps below to verify the board operation. **Caution: Do not turn on power supply or the electronic load until all connections are made.**

- 1) Connect the positive terminal of the +3.3V supply to the VBATT PCB pad and the negative terminal of the supply to the GND PCB pad closest to the VBATT PCB pad.
- 2) Set the electronic load to 1A.
- 3) Connect the electronic load's positive terminal to the LOAD PCB pad and the negative terminal to the nearest GND PCB pad on the EV kit.
- 4) Connect the first voltmeter across the RS+ and RS- test points.
- 5) Connect the second voltmeter across VOUT and the nearest GND PCB pad on the EV kit.
- 6) Enable the power supply.
- 7) Enable the electronic load.
- 8) Verify that the first DVM displays 60mV and the second DVM displays 3.0V.

Detailed Description of Hardware

The MAX44286 EV kit provides a proven design to evaluate the MAX44286 zero-drift, high-side, current-sense amplifier that offers precision accuracy specifications of V_{OS} less than $7\mu V$ (max) and gain error less than 0.2% (max).

Applying the V_{RS+} Supply and the Load

The EV kit is installed with a MAX44286FAZS+, which has a 50V/V gain. The current-sense resistor (R_{SENSE}) value is 0.05Ω with $\pm 0.5\%$ tolerance. The V_{OUT} is given by:

$$V_{OUT} = I_{LOAD} \times R_{SENSE} \times A_V$$

where A_V is the gain and I_{LOAD} is the current load applied to the device. Normal operating V_{RS+} and V_{RS-} range is +1.8V to +5.5V.

Measuring the Load Current

The load current is measured as a voltage drop (V_{SENSE}) across an external sense resistor. This voltage is then amplified by the current-sense amplifier and presented at its OUT pin. Like all differential amplifiers, the output voltage has two components of error (an offset error and a gain error). The offset error affects accuracy at low currents and a gain error affects accuracy at large currents—both errors affect accuracy at intermediate currents. By minimizing both offset and gain errors, accuracy can be optimized over a wide dynamic range.

Evaluating Other Gain Versions

The MAX44286 EV kit can be used to evaluate other gain versions of the MAX44286 (25V/V, 50V/V, 100V/V, 200V/V = T, F, H, Z suffix). Replace U1 of the MAX44286 EV kit with the appropriate version of the MAX44286.

Component List

Refer to file "evkit_build_bom_max44286_evkit_a.csv" attached to this PDF for component information.

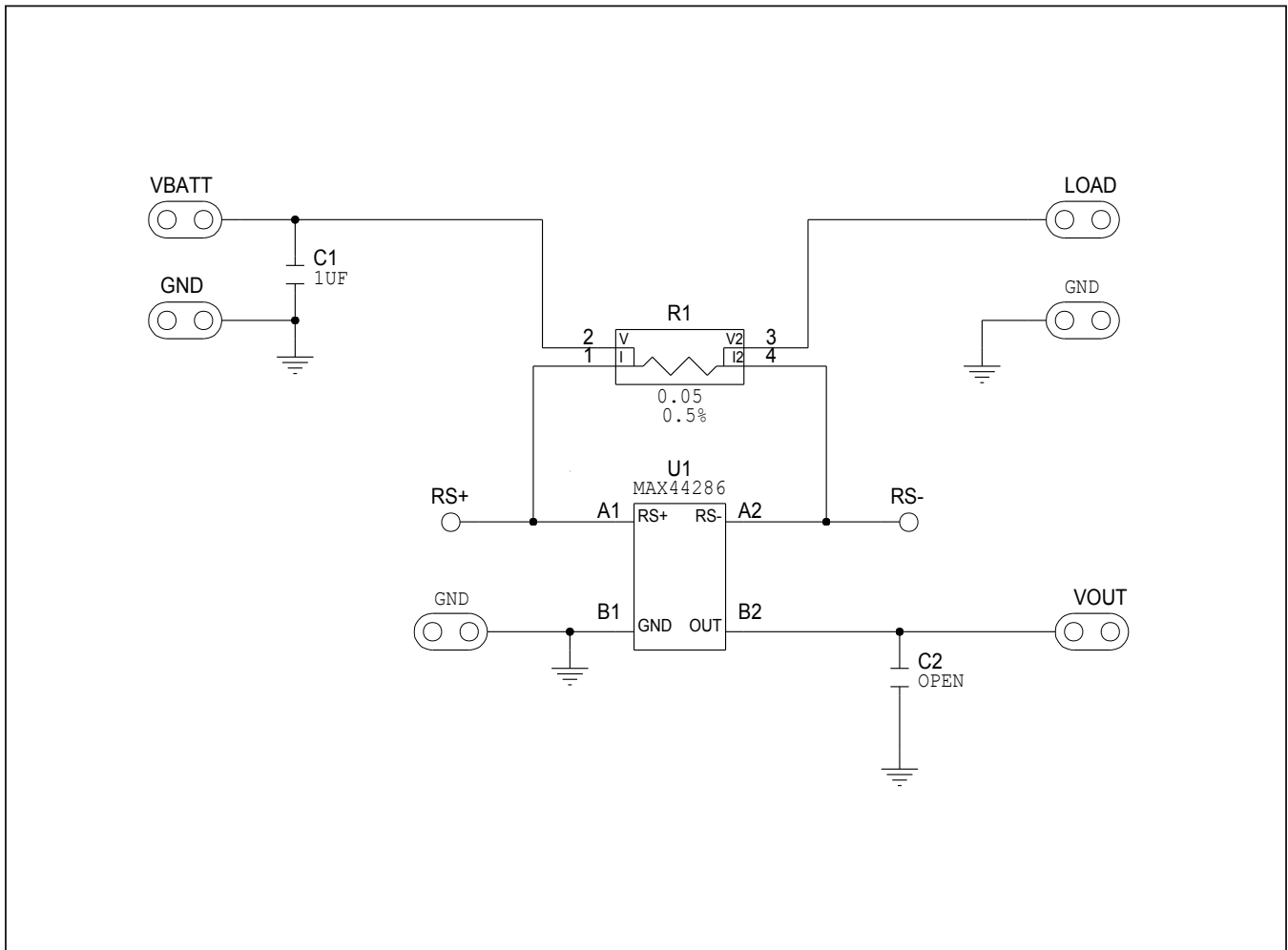

Figure 1. MAX44286 EV Kit Schematic

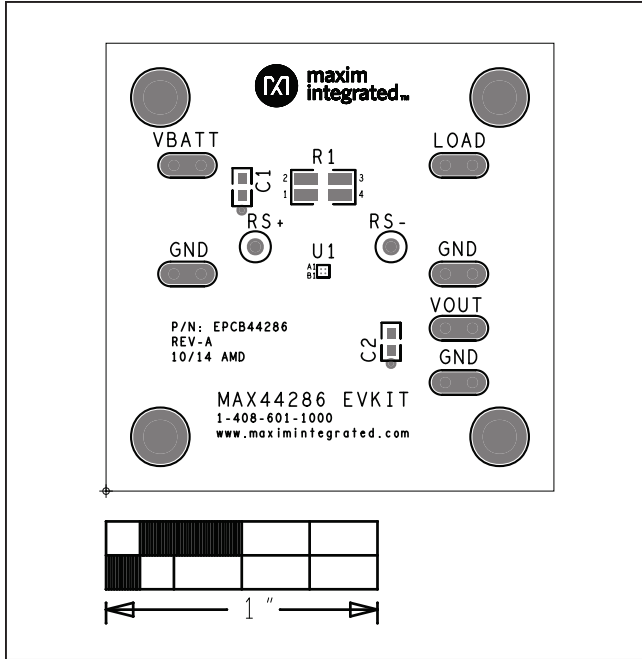

Figure 2. MAX44286 EV Kit Component Placement Guide—Component Side

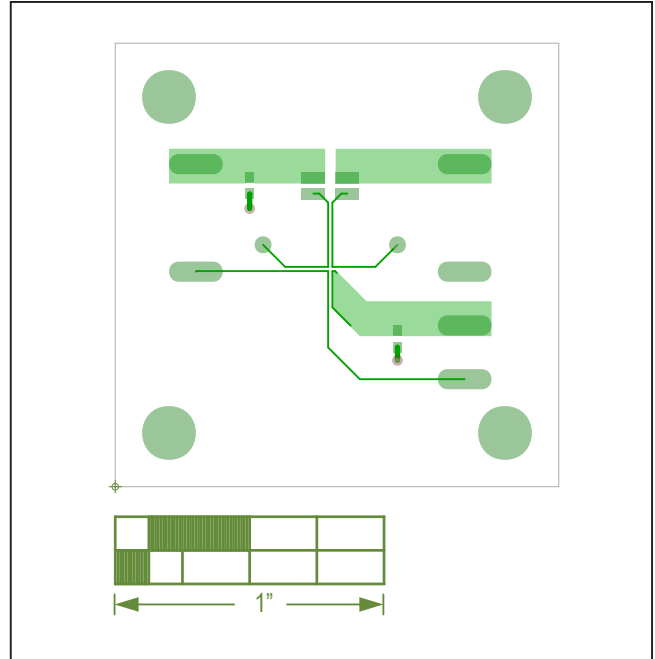

Figure 3. MAX44286 EV Kit PCB Layout—Component Side

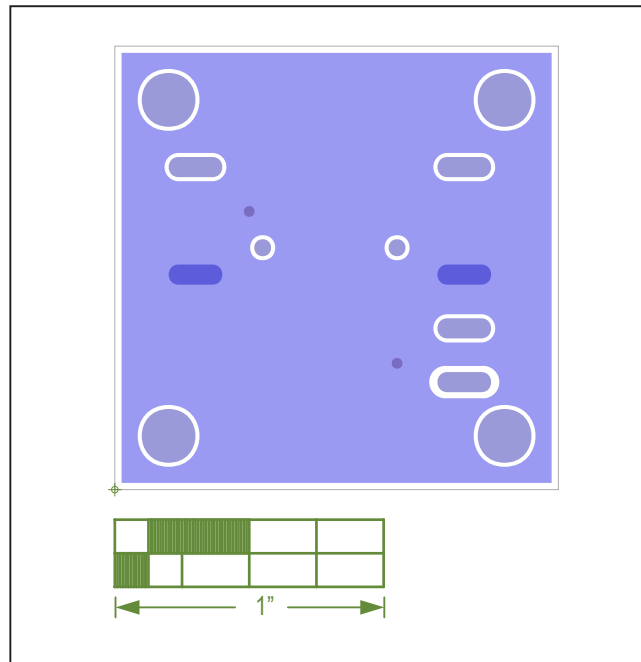

Figure 4. MAX44286 EV Kit PCB Layout—Solder Side

Ordering Information

PART	TYPE
MAX44286EVKIT#	EV Kit

#RoHS compliant.

Revision History

REVISION NUMBER	REVISION DATE	DESCRIPTION	PAGES CHANGED
0	10/14	Initial release	—

For pricing, delivery, and ordering information, please contact Maxim Direct at 1-888-629-4642, or visit Maxim Integrated's website at www.maximintegrated.com.

Maxim Integrated cannot assume responsibility for use of any circuitry other than circuitry entirely embodied in a Maxim Integrated product. No circuit patent licenses are implied. Maxim Integrated reserves the right to change the circuitry and specifications without notice at any time.

X-ON Electronics

Largest Supplier of Electrical and Electronic Components

Click to view similar products for [Amplifier IC Development Tools](#) category:

Click to view products by [Maxim](#) manufacturer:

Other Similar products are found below :

[AD8033AKS-EBZ](#) [AD8044AR-EBZ](#) [AD744JR-EBZ](#) [AD8023AR-EBZ](#) [AD848JR-EBZ](#) [ADA4922-1ACP-EBZ](#) [EVAL-ADCMP553BRMZ](#)
[EVAL-ADCMP608BKSZ](#) [MIOP 42109](#) [EVAL-ADCMP609BRMZ](#) [ADA4950-1YCP-EBZ](#) [MAX2634EVKIT](#) [ISL28158EVAL1Z](#) [MADL-](#)
[011014-001SMB](#) [AD8137YCP-EBZ](#) [EVAL-ADA4523-1ARMZ](#) [EVAL01-HMC1013LP4E](#) [MCP6XXXEV-AMP3](#) [MCP6XXXEV-AMP4](#)
[MCP6XXXEV-AMP2](#) [ISL28006FH-100EVAL1Z](#) [551012922-001/NOPB](#) [EVAL-ADCMP603BCPZ](#) [AMC1200EVM](#) [AD8417RM-EVALZ](#)
[DEM-OPA-SOT-1A](#) [DEM-OPA-SO-1C](#) [DEM-BUF-SOT-1A](#) [OPA2836IDGSEVM](#) [AD633-EVALZ](#) [AD8418R-EVALZ](#)
[ISL28433SOICEVAL1Z](#) [ISL28233SOICEVAL1Z](#) [ISL28208SOICEVAL2Z](#) [ISL28207SOICEVAL2Z](#) [ISL28006FH-50EVAL1Z](#)
[ISL28005FH-50EVAL1Z](#) [120257-HMC613LC4B](#) [DC1591A](#) [DC1150A](#) [DC1115A](#) [DC954A-C](#) [DC306A-A](#) [DC1192A](#) [131679-](#)
[HMC813LC4B](#) [OPA2835IDGSEVM](#) [LMH730220/NOPB](#) [MAAP-011246-1SMB](#) [118329-HMC627ALP5](#) [125932-HMC874LC3C](#)