

MAX4599

Low-Voltage, Single-Supply, SPDT Analog Switch in SC70

General Description

The MAX4599 single-pole/double-throw (SPDT) switch operates from a +2.0V to +5.5V single supply. It offers 60Ω max on-resistance (R_{ON}) at +5V and fast switching times ($t_{ON} = 30\text{ns}$ max, $t_{OFF} = 25\text{ns}$ max).

The MAX4599 features excellent R_{ON} flatness (4Ω max) and matching (1Ω max) between channels. This device also offers 5pC max charge injection.

The MAX4599 is available in tiny 6-pin SC70, μDFN , and SOT23 packages.

Applications

- Battery-Operated Equipment
- Audio and Video Signal Routing
- Cellular Phones
- Low-Voltage Data-Acquisition Systems
- Sample-and-Hold Circuits
- Communications Circuits

Features

- Available in 6-Pin SC70 Package
- 60Ω max (40Ω typ) On-Resistance
- 1Ω max (0.2Ω typ) R_{ON} Matching Between Channels
- 4Ω max (2.5Ω typ) R_{ON} Flatness
- Fast Switching: $t_{ON} = 30\text{ns}$ (max)
 $t_{OFF} = 25\text{ns}$ (max)
- Guaranteed 5pC max Charge Injection
- +2.0V to +5.5V Single-Supply Operation
- 200MHz -3dB Bandwidth
- Low $\pm 0.5\text{nA}$ Leakage Current at +25°C
- Break-Before-Make Switching
- TTL/CMOS-Logic Compatible
- -76dB Off-Isolation at 1MHz
- 0.12% Total Harmonic Distortion

Pin Configuration/Functional Diagram/Truth Table

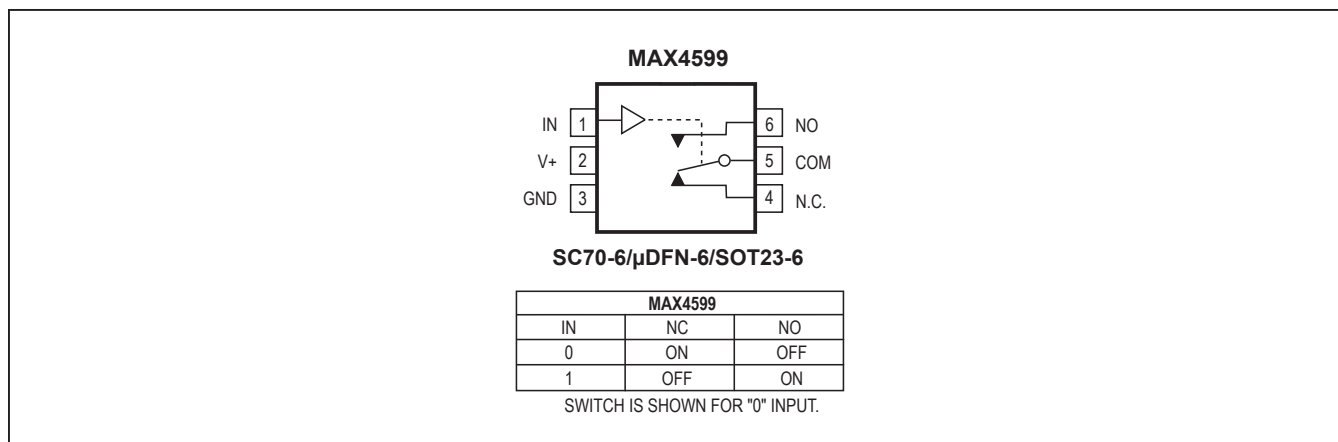

Absolute Maximum Ratings

Voltage Referenced to GND

V+	-0.3V to +6V
IN, COM, NO, NC (Note 1)	-0.3V to (V+ + 0.3V)
Continuous Current (any terminal)	±20mA
Peak Current, COM, NO, N.C. (pulsed at 1ms, 10% duty cycle)	±40mA

Continuous Power Dissipation (T_A = +70°C)

6-Pin SC70-6 (derate 3.1mW/°C above +70°C).....	245mW
6-Pin µDFN-6 (derate 2.1mW/°C above +70°C).....	168mW
6-Pin SOT23-6 (derate 7.1mW/°C above +70°C).....	571mW
Operating Temperature Range	
MAX4599E_T	-40°C to +85°C
Storage Temperature Range	-65°C to +150°C
Lead Temperature (soldering, 10s)	+300°C

Note 1: Signals on NO, NC, COM, or IN exceeding V+ or GND are clamped by internal diodes. Limit forward-diode current to maximum current rating.

Stresses beyond those listed under "Absolute Maximum Ratings" may cause permanent damage to the device. These are stress ratings only, and functional operation of the device at these or any other conditions beyond those indicated in the operational sections of the specifications is not implied. Exposure to absolute maximum rating conditions for extended periods may affect device reliability.

Electrical Characteristics—Single +5V Supply

(V+ = +4.5V to +5.5V, V_{INH} = +2.4V, V_{INL} = +0.8V, T_A = T_{MIN} to T_{MAX}, unless otherwise noted.) (Notes 2, 3)

PARAMETER	SYMBOL	CONDITIONS	MIN	TYP	MAX	UNITS	
ANALOG SWITCH							
Analog Signal Range	V _{COM} , V _{NO} , V _{NC}		0		V+	V	
On-Resistance	R _{ON}	V+ = 4.5V, I _{COM} = 1mA, V _{NO} or V _{NC} = 3.5V	T _A = +25°C	40	60	Ω	
			T _A = T _{MIN} to T _{MAX}		65		
On-Resistance Match Between Channels (Note 4)	ΔRON	V+ = 4.5V, I _{COM} = 1A, V _{NO} or V _{NC} = 3.5V	T _A = +25°C	0.2	1	Ω	
			T _A = T _{MIN} to T _{MAX}		2		
On-Resistance Flatness (Note 5)	R _{FLAT(ON)}	V+ = 4.5V; I _{COM} = 1mA; V _{NO} or V _{NC} = 1V, 2.0V, 3.5V	T _A = +25°C	2.5	4	Ω	
			T _A = T _{MIN} to T _{MAX}		5		
NO, NC Off-Leakage Current (Note 6)	I _{NO(OFF)} , I _{NC(OFF)}	V+ = 5.5V; V _{COM} = 1V, 4.5V; V _{NO} or V _{NC} = 4.5V, 1V	T _A = +25°C	-0.5	0.01	0.5	nA
			T _A = T _{MIN} to T _{MAX}	-5		5	
COM On-Leakage Current (Note 6)	I _{COM(ON)}	V+ = 5.5V; V _{COM} = 1V, 4.5V; V _{NO} or V _{NC} = 1V, 4.5V, or floating	T _A = +25°C	-1	0.01	1	nA
			T _A = T _{MIN} to T _{MAX}	-10		10	
DIGITAL I/O							
Input Logic High	V _{IH}		2.4			V	
Input Logic Low	V _{IL}				0.8	V	
DYNAMIC							
Turn-On Time	t _{ON}	V _{NO} , V _{NC} = 3V; R _L = 1kΩ; C _L = 35pF; Figure 2	T _A = +25°C	25	30	ns	
			T _A = T _{MIN} to T _{MAX}		40		

Electrical Characteristics—Single +5V Supply (continued)(V+ = +4.5V to +5.5V, V_{INH} = +2.4V, V_{INL} = +0.8V, T_A = T_{MIN} to T_{MAX}, unless otherwise noted.) (Notes 2, 3)

PARAMETER	SYMBOL	CONDITIONS	MIN	TYP	MAX	UNITS
Turn-Off Time	t _{OFF}	V _{NO} , V _{NC} = 3V; R _L = 1kΩ; C _L = 35pF; Figure 2	T _A = +25°C	20	25	ns
			T _A = T _{MIN} to T _{MAX}		30	
Break-Before-Make	t _{BBM}	V _{NO} , V _{NC} = 3V; R _L = 1kΩ; C _L = 35pF; Figure 3	T _A = +25°C	10		ns
			T _A = T _{MIN} to T _{MAX}	1		
On-Channel -3dB Bandwidth	BW	Signal = 0dBm, 50Ω in and out, Figure 5	T _A = +25°C	200		MHz
Off-Isolation (Note 7)	V _{ISO}	C _L = 5pF; R _L = 50Ω; f = 1MHz; V _{NO} , V _{NC} = 1V _{RMS} ; Figure 5	T _A = +25°C	-76		dB
Charge Injection (Note 6)	Q	V _{GEN} = 0, R _{GEN} = 0, C _L = 1.0nF, Figure 4	T _A = +25°C	3	5	pC
NO, NC Off-Capacitance	C _{NO(OFF)} , C _{NC(OFF)}	V _{NO} , V _{NC} = GND; f = 1MHz; Figure 6	T _A = +25°C	8		pF
COM Off-Capacitance	C _{COM(OFF)}	V _{COM} = GND, f = 1MHz, Figure 6	T _A = +25°C	8		pF
Switch On-Capacitance	C _(ON)	V _{COM} = V _{NO} , V _{NC} = GND, f = 1MHz, Figure 6	T _A = +25°C	20		pF
Total Harmonic Distortion	THD	R _L = 600Ω, V _{IN} = 5Vp-p, f = 20Hz to 20kHz	T _A = +25°C	0.12		%
SUPPLY						
Power-Supply Range	V+		2.0		5.5	V
Positive Supply Current	I+	V+ = 5.5V, V _{IN} = 0 or V+	-1	0.001	1	μA

Electrical Characteristics—Single +3V Supply(V+ = +2.7V to +3.6V, V_{INH} = +2.0V, V_{INL} = +0.8V, T_A = T_{MIN} to T_{MAX}, unless otherwise noted.) (Notes 2, 3)

PARAMETER	SYMBOL	CONDITIONS	MIN	TYP	MAX	UNITS
ANALOG SWITCH						
Analog Signal Range	V _{COM} , V _{NO} , V _{NC}		0		V+	V
On-Resistance	R _{ON}	V+ = 2.7V, I _{COM} = 1mA, V _{NO} or V _{NC} = 1V	T _A = +25°C	60	95	Ω
			T _A = T _{MIN} to T _{MAX}		105	
DIGITAL I/O						
Input Logic High	V _{IH}		2.0			V
Input Logic Low	V _{IL}				0.8	V

Electrical Characteristics—Single +3V Supply (continued)(V+ = +2.7V to +3.6V, V_{INH} = +2.0V, V_{INL} = +0.8V, T_A = T_{MIN} to T_{MAX}, unless otherwise noted.) (Notes 2, 3)

PARAMETER	SYMBOL	CONDITIONS	MIN	TYP	MAX	UNITS
DYNAMIC						
Turn-On Time	t _{ON}	V _{NO} , V _{NC} = 2V; R _L = 1kΩ; C _L = 35pF; Figure 2	T _A = +25°C	40	45	ns
			T _A = T _{MIN} to T _{MAX}		55	
Turn-Off Time	t _{OFF}	V _{NO} , V _{NC} = 2V; R _L = 1kΩ; C _L = 35pF; Figure 2	T _A = +25°C	30	35	ns
			T _A = T _{MIN} to T _{MAX}		40	
Break-Before-Make	t _{BBM}	V _{NO} , V _{NC} = 2V; R _L = 1kΩ; C _L = 35pF; Figure 3	T _A = +25°C	13		ns
			T _A = T _{MIN} to T _{MAX}	1		
Charge Injection (Note 6)	Q	V _{GEN} = 0, R _{GEN} = 0, C _L = 1.0nF, Figure 4	T _A = +25°C	2	5	pC
SUPPLY						
Positive Supply Current	I+	V+ = 3.6V, V _{IN} = 0 or V+	-1	0.001	1	μA

Electrical Characteristics—Single +2.5V Supply(V+ = +2.5V, V_{INH} = +2.0V, V_{INL} = +0.6V, T_A = T_{MIN} to T_{MAX}, unless otherwise noted.) (Notes 2, 3)

PARAMETER	SYMBOL	CONDITIONS	MIN	TYP	MAX	UNITS
ANALOG SWITCH						
Analog Signal Range	V _{COM} , V _{NO} , V _{NC}		0		V+	V
On-Resistance	R _{ON}	V+ = 2.5V, I _{COM} = 1mA, V _{NO} or V _{NC} = 1V	T _A = +25°C	65	110	Ω
			T _A = T _{MIN} to T _{MAX}		120	
Input Logic High	V _{IH}		2.0			V
Input Logic Low	V _{IL}				0.6	V
DYNAMIC						
Turn-On Time	t _{ON}	V _{NO} , V _{NC} = 2V; R _L = 1kΩ; C _L = 35pF; Figure 3	T _A = +25°C	45	50	ns
			T _A = T _{MIN} to T _{MAX}		60	
Turn-Off Time	t _{OFF}	V _{NO} , V _{NC} = 3V; R _L = 1kΩ; C _L = 35pF; Figure 3	T _A = +25°C	30	35	ns
			T _A = T _{MIN} to T _{MAX}		45	

Note 2: Parameters are 100% tested at +25°C only and guaranteed by correlation at the full rated temperature.**Note 3:** The algebraic convention, where the most negative value is a minimum and the most positive value a maximum, is used in this data sheet.**Note 4:** ΔR_{ON} = R_{ON}(MAX) - R_{ON}(MIN).**Note 5:** Flatness is defined as the difference between the maximum and minimum value of on-resistance as measured over the specified analog signal ranges.**Note 6:** Guaranteed by design.**Note 7:** Off-Isolation = 20log₁₀ (V_{COM} / V_{NO}), V_{COM} = output, V_{NO} = input to off switch.

Typical Operating Characteristics

($T_A = +25^\circ\text{C}$, unless otherwise noted.)

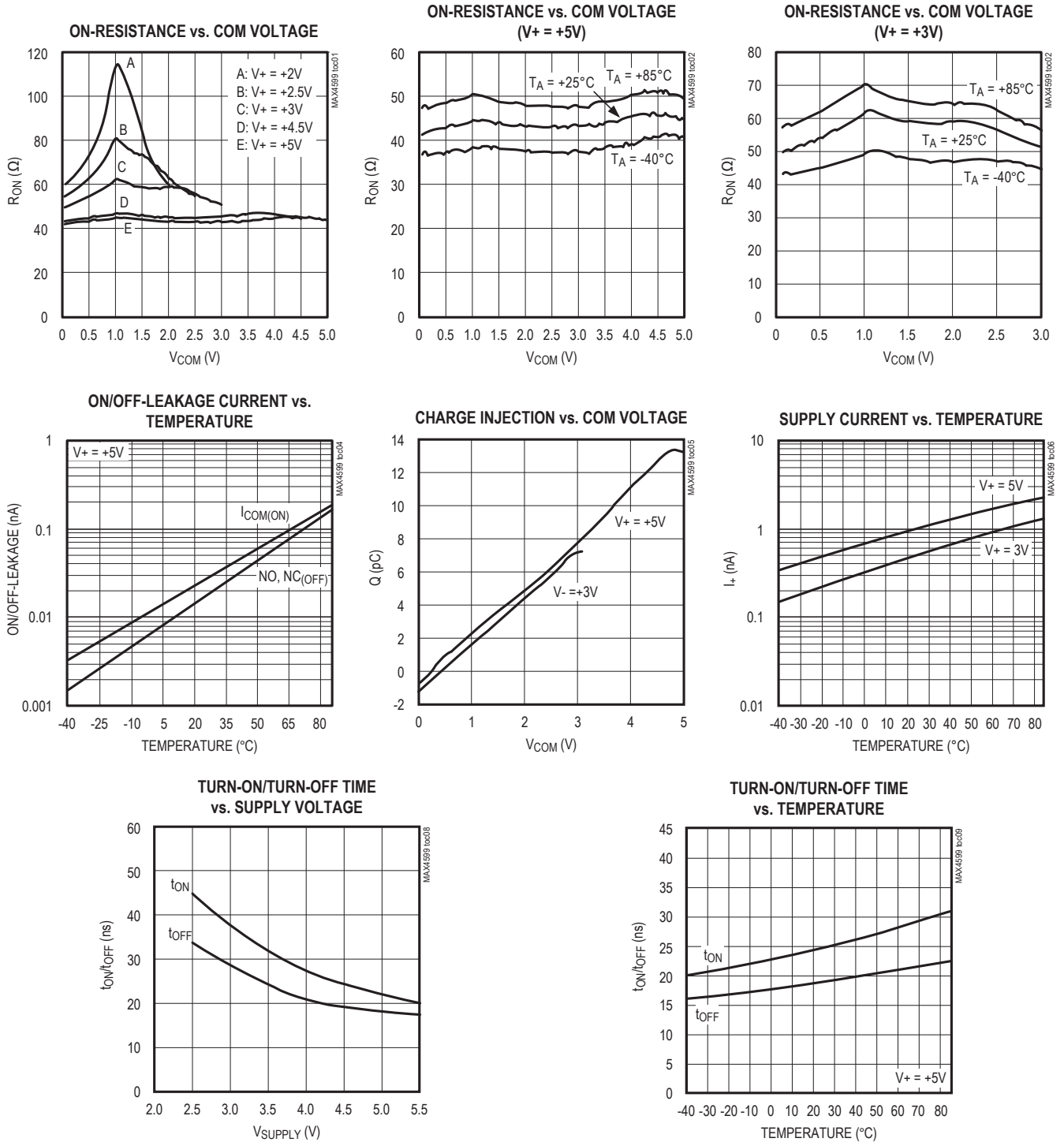

Typical Operating Characteristics (continued)

(T_A = +25°C, unless otherwise noted.)

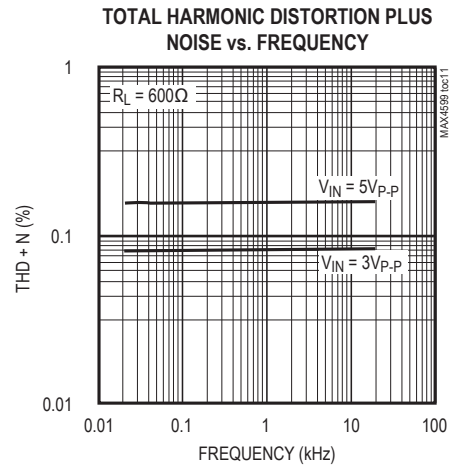
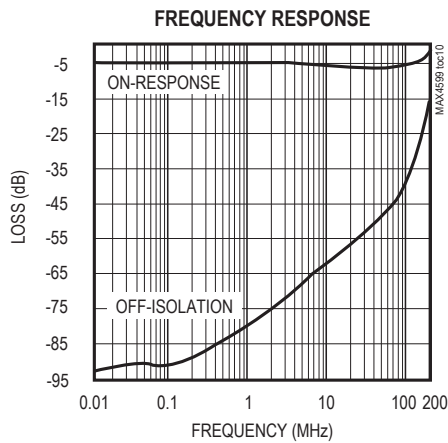

Pin Description

PIN	NAME	FUNCTION
1	IN	Digital Control Input
2	V+	Positive Supply Voltage
3	GND	Ground
4	N.C.	Analog Switch Normally Closed
5	COM	Analog Switch Common
6	NO	Analog Switch Normally Open

Applications Information

Analog Signal Levels

Analog signals can range over the supply voltage (V+ to GND) with on-resistance changing very little over the entire range (see *Typical Operating Characteristics*). The MAX4599 is bidirectional, so the NO, NC, and COM pins can be used either as inputs or outputs.

Power-Supply Sequencing and Overvoltage Protection

Proper power-supply sequencing is recommended for all CMOS devices. Always apply V+ before applying analog signals or logic inputs, especially if the analog or logic signals are not current limited. If this sequencing is not possible, and if the analog or logic inputs are not current limited to < 20mA, add a small-signal diode (D1) as shown in Figure 1. If the analog signal can dip below GND, add D2.

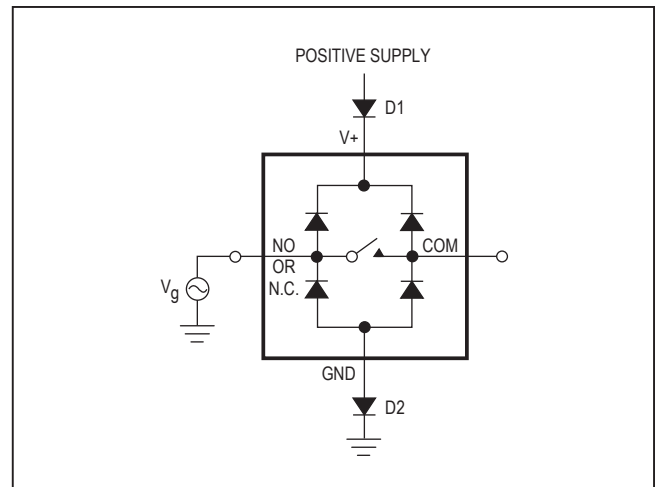

Figure 1. Overvoltage Protection Using Two External Blocking Diodes

Adding protection diodes reduces the analog signal range to a diode drop (about 0.7V) below V+ for D1 or to a diode drop above ground for D2. The addition of diodes does not affect leakage. On-resistance increases by a small amount at low supply voltages. Maximum supply voltage (V+) must not exceed 6V.

Protection diodes D1 and D2 also protect against some overvoltage situations. A fault voltage up to the absolute maximum rating at an analog signal input does not damage the device, even if the supply voltage is below the signal voltage.

Test Circuits/Timing Diagrams

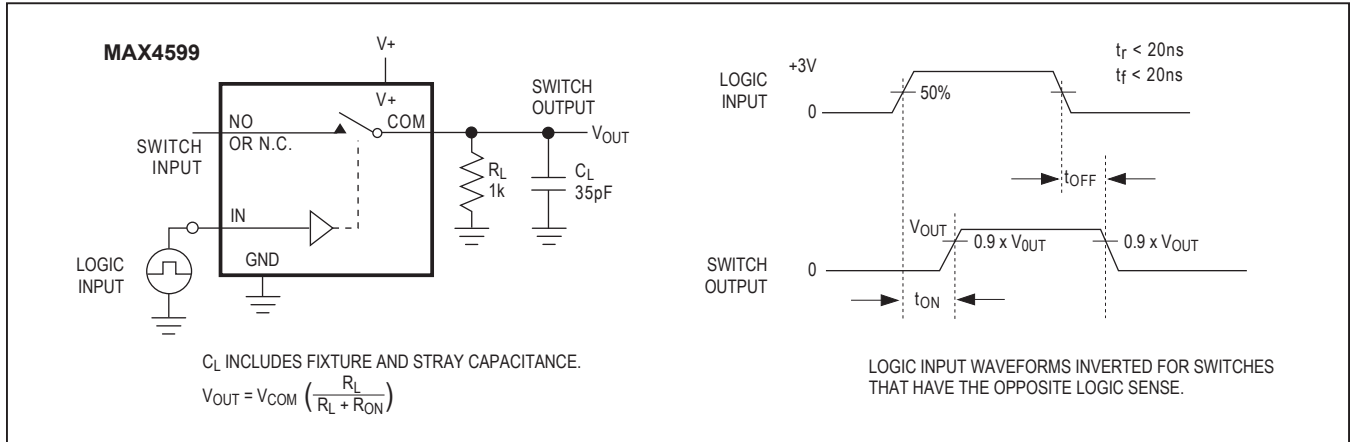

Figure 2. Switching Time

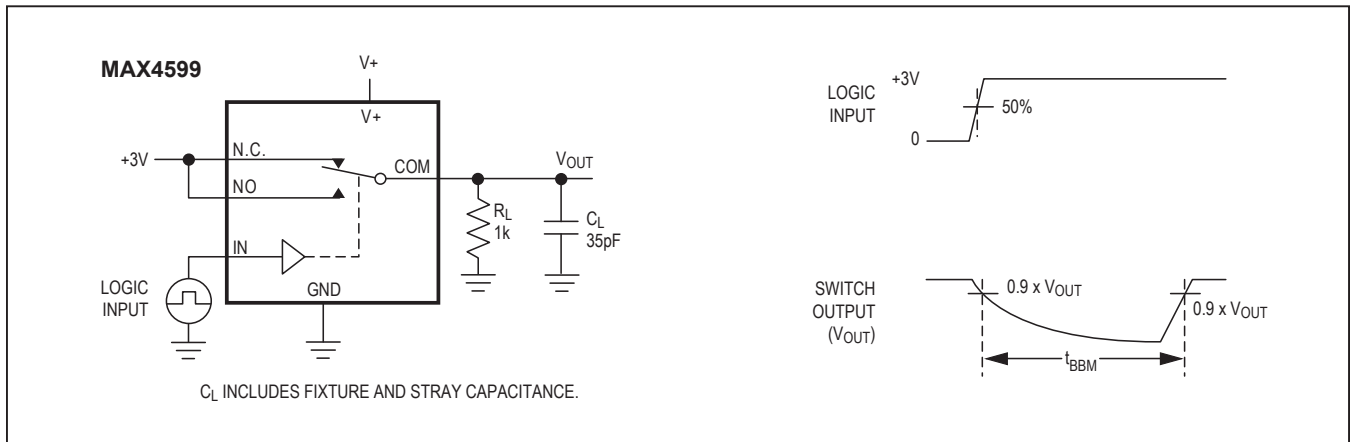

Figure 3. Break-Before-Make Interval

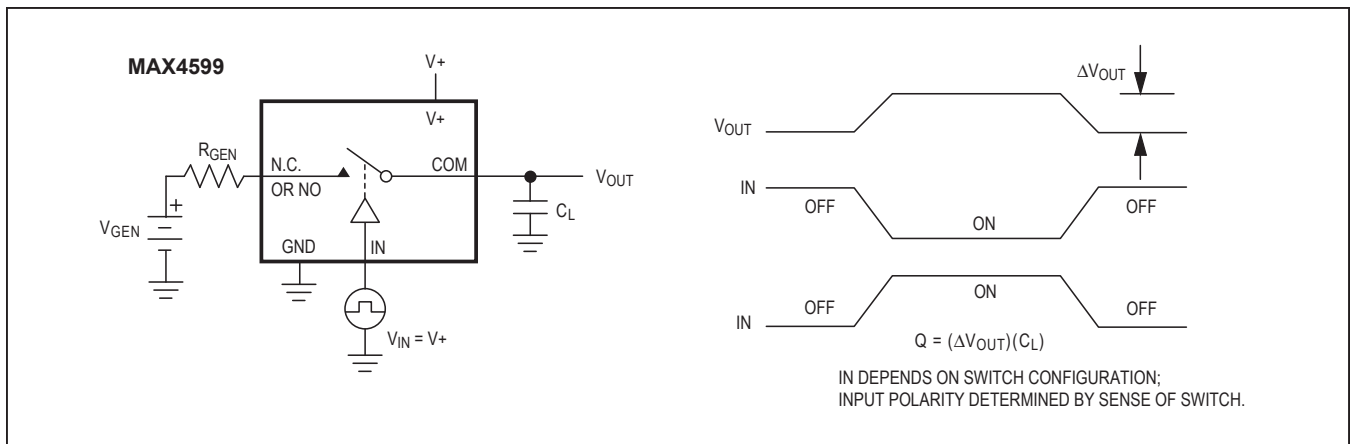

Figure 4. Charge Injection

Test Circuits/Timing Diagrams (continued)

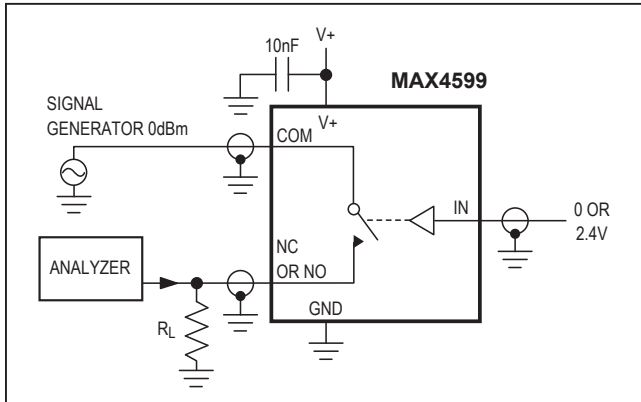

Figure 5. Off-Isolation/On-Channel Bandwidth

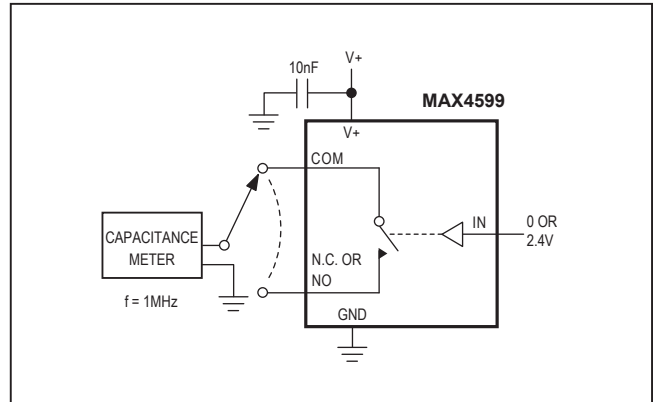

Figure 6. Channel On/Off-Capacitance

Ordering Information

PART	TEMP RANGE	PIN-PACKAGE	TOP MARK
MAX4599EXT+T	-40°C to +85°C	6 SC70-6	AAF
MAX4599EUT+T	-40°C to +85°C	6 SOT23-6	AAHC
MAX4599ELT+T	-40°C to +85°C	6 μ DFN-6	AA

Chip Information

TRANSISTOR COUNT: 89

Package Information

For the latest package outline information and land patterns (footprints), go to www.maximintegrated.com/packages. Note that a "+", "#", or "-" in the package code indicates RoHS status only. Package drawings may show a different suffix character, but the drawing pertains to the package regardless of RoHS status.

PACKAGE TYPE	PACKAGE CODE	OUTLINE NO.	LAND PATTERN NO.
6 SC70	X6SN-1	21-0077	90-0189
6 μ DFN	L611-1	21-0147	90-0080
6 SOT23	U6SN+1	21-0058	90-0175

Revision History

REVISION NUMBER	REVISION DATE	DESCRIPTION	PAGES CHANGED
3	2/18	Updated <i>Ordering Information</i> table and created <i>Packaging Information</i> table	
4	2/21	Updated <i>Package Information</i> table for 6-SOT23.	8

For pricing, delivery, and ordering information, please contact Maxim Direct at 1-888-629-4642, or visit Maxim Integrated's website at www.maximintegrated.com.

Maxim Integrated cannot assume responsibility for use of any circuitry other than circuitry entirely embodied in a Maxim Integrated product. No circuit patent licenses are implied. Maxim Integrated reserves the right to change the circuitry and specifications without notice at any time. The parametric values (min and max limits) shown in the Electrical Characteristics table are guaranteed. Other parametric values quoted in this data sheet are provided for guidance.

X-ON Electronics

Largest Supplier of Electrical and Electronic Components

Click to view similar products for [Analogue Switch ICs](#) category:

Click to view products by [Maxim](#) manufacturer:

Other Similar products are found below :

[FSA3051TMX](#) [NLAS4684FCTCG](#) [NLAS5223BLMNR2G](#) [NLVAS4599DTT1G](#) [NLX2G66DMUTCG](#) [425541DB](#) [425528R](#) [099044FB](#)
[NLAS5123MNR2G](#) [PI5A4157CEX](#) [NLAS4717EPFCT1G](#) [PI5A3167CCEX](#) [SLAS3158MNR2G](#) [PI5A392AQE](#) [PI5A4157ZUEX](#)
[PI5A3166TAEX](#) [FSA634UCX](#) [XS3A1T3157GMX](#) [TC4066BP\(N,F\)](#) [DG302BDJ-E3](#) [PI5A100QEX](#) [HV2605FG-G](#) [HV2301FG-G](#)
[RS2117YUTQK10](#) [RS2118YUTQK10](#) [RS2227XUTQK10](#) [ADG452BRZ-REEL7](#) [MAX4066ESD+](#) [MAX391CPE+](#) [MAX4730EXT+T](#)
[MAX314CPE+](#) [BU4066BCFV-E2](#) [MAX313CPE+](#) [BU4S66G2-TR](#) [NLASB3157MTR2G](#) [TS3A4751PWR](#) [NLAS4157DFT2G](#)
[NLAST4599DFT2G](#) [NLAST4599DTT1G](#) [DG419LDY+T](#) [DG300BDJ-E3](#) [DG2503DB-T2-GE1](#) [TC4W53FU\(TE12L,F\)](#) [HV2201FG-G](#)
[74HC2G66DC.125](#) [DG3257DN-T1-GE4](#) [ADG1611BRUZ-REEL7](#) [DG2535EDQ-T1-GE3](#) [LTC201ACN#PBF](#) [74LV4066DB,118](#)