



Push-Pull FET Driver with Integrated Oscillator and Programmable Clock Output

MAX5077

General Description

The MAX5077 is a +4.5V to +15V push-pull, current-fed topology driver subsystem with an integrated oscillator used in telecom module power supplies. The device drives two MOSFETs connected to a center-tapped transformer primary providing secondary-side, isolated, negative or positive voltages. The MAX5077 features a programmable accurate integrated oscillator with a synchronizing clock output to synchronize an external PWM regulator. A single external resistor programs the internal oscillator frequency from 50kHz to 1.5MHz.

The MAX5077 incorporates dual MOSFET drivers with $\pm 3A$ peak drive currents and 50% duty cycle. The MOSFET drivers generate complementary signals to drive external ground-referenced n-channel MOSFETs.

The MAX5077 clock output frequency is programmable by logic inputs to set the clock output to 1x, 2x, or 4x the MOSFET's driver frequency.

The MAX5077 is available in a 14-pin exposed pad TSSOP package and is specified over the $-40^{\circ}C$ to $+125^{\circ}C$ operating temperature range.

Applications

Current-Fed Power Supplies
Power-Supply Building Subsystems
Push-Pull Driver Subsystems

Features

- ◆ Dedicated Current-Fed, Push-Pull Driver Subsystem
- ◆ Oscillator Frequency Programmable from 50kHz to 1.5MHz
- ◆ Single +4.5V to +15V Supply Voltage Range
- ◆ $\pm 3A$ Peak Gate-Drive Current
- ◆ 1mA Operating Current at 250kHz with No Capacitive Load
- ◆ Selectable Synchronizing Clock Frequency for a Preceding PWM Stage
- ◆ Thermally Enhanced 14-Pin TSSOP
- ◆ $-40^{\circ}C$ to $+125^{\circ}C$ Operating Temperature Range

Ordering Information

PART	TEMP RANGE	PIN-PACKAGE	PKG CODE
MAX5077AUD	$-40^{\circ}C$ to $+125^{\circ}C$	14 TSSOP-EP*	U14E-3

*EP = Exposed paddle.

Pin Configuration appears at end of data sheet.

Typical Operating Circuit

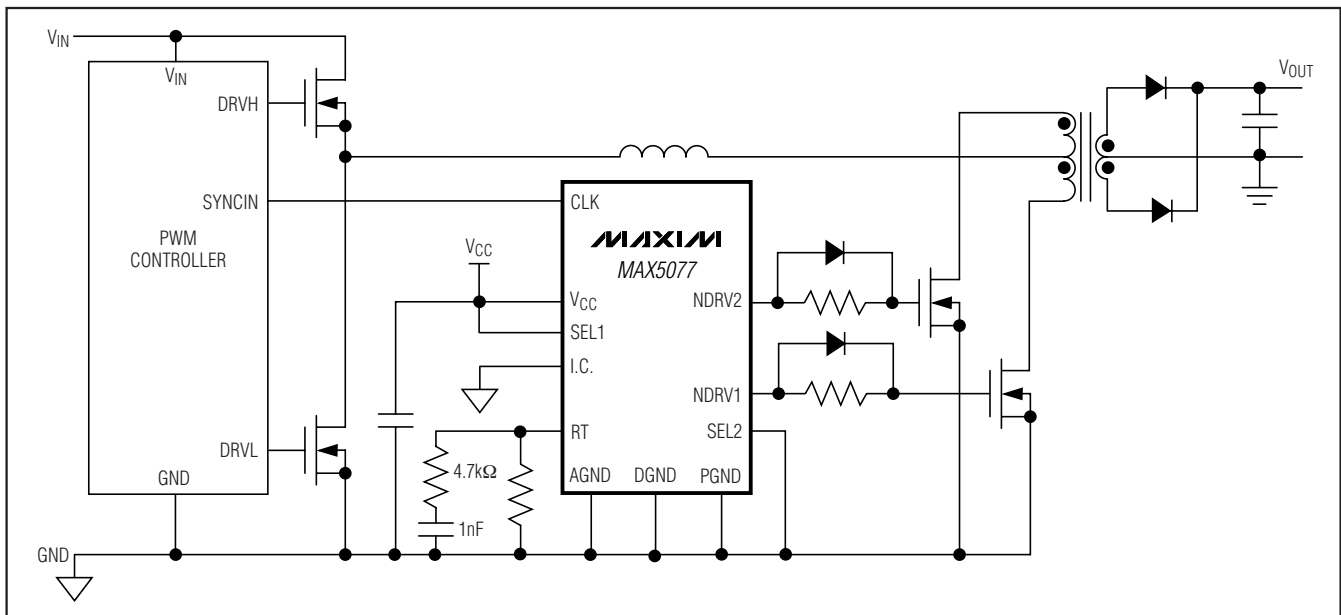

Push-Pull FET Driver with Integrated Oscillator and Programmable Clock Output

ABSOLUTE MAXIMUM RATINGS

V _{CC} to AGND, DGND, PGND	-0.3V to +18V
PGND, DGND to AGND	-0.3V to +0.3V
SEL1, SEL2 to DGND	-0.3V to +18V
CLK, RT to AGND	-0.3V to +6V
NDRV1, NDRV2 to PGND	-0.3V to (V _{CC} + 0.3V)
CLK Current	±20mA
NDRV1, NDRV2 Peak Current (200ns)	±5A
NDRV1, NDRV2 Reverse Current (Latchup Current)	±500mA

Continuous Power Dissipation (T_A = +70°C)

14-Pin TSSOP (derate 20.8mW/°C above +70°C)	1667mW
Operating Temperature Range	-40°C to +125°C
Maximum Junction Temperature	+150°C
Storage Temperature Range	-60°C to +150°C
Lead Temperature (soldering, 10s)	+300°C

Stresses beyond those listed under "Absolute Maximum Ratings" may cause permanent damage to the device. These are stress ratings only, and functional operation of the device at these or any other conditions beyond those indicated in the operational sections of the specifications is not implied. Exposure to absolute maximum rating conditions for extended periods may affect device reliability.

ELECTRICAL CHARACTERISTICS

(V_{CC} = +12V, SEL1 = V_{CC}, SEL2 = DGND, R_{RT} = 124kΩ, NDRV1 = NDRV2 = open, T_A = T_J = -40°C to +125°C, unless otherwise noted. Typical values are at T_A = +25°C.) (Note 1)

PARAMETER	SYMBOL	CONDITIONS	MIN	TYP	MAX	UNITS
SUPPLY						
Input Voltage Supply Range	V _{CC}		4.5		15.0	V
Static Supply Current	I _{CCST}	SEL2 = SEL1 = DGND, drivers not switching		150	320	μA
Switching Supply Current	I _{CCSW}	SEL2 = DGND, SEL1 = V _{CC} , f _{OSC} = 250kHz		1	3	mA
Undervoltage Lockout	V _{UVLO}	V _{CC} rising	3	3.5	4	V
UVLO Hysteresis				300		mV
OSCILLATOR						
Frequency Range	f _{OSC}	(Note 2)	50		1500	kHz
Accuracy		f _{OSC} = 250kHz, 6V ≤ V _{CC} ≤ 15V (Note 3)	-8		+10	%
Oscillator Jitter				±0.6		%
CLK Output High Voltage	I _{CLK} = 1mA	7V ≤ V _{CC} ≤ 15V	3.9		5.0	V
		4.5V ≤ V _{CC} ≤ 7V	3.35		5.0	
CLK Output Low Voltage	I _{CLK} = -1mA				50	mV
CLK Output Rise Time		C _{CLK} = 30pF		35		ns
CLK Output Fall Time		C _{CLK} = 30pF		10		ns
GATE DRIVERS (NDRV1, NDRV2)						
Output High Voltage	V _{OH}	I _{NDRV1} = I _{NDRV2} = 100mA	V _{CC} - 0.3			V
Output Low Voltage	V _{OL}	I _{NDRV1} = I _{NDRV2} = -100mA			0.3	V
Output Peak Current	I _P	Sourcing and sinking		3		A
Driver Output Impedance		NDRV_ sourcing 100mA		1.8	3	Ω
		NDRV_ sinking 100mA		1.6	2.6	
Latchup Current Protection		Reverse current at NDRV1/NDRV2		400		mA
Rise Time	t _R	C _{LOAD} = 2nF		10		ns
Fall Time	t _F	C _{LOAD} = 2nF		10		ns

Push-Pull FET Driver with Integrated Oscillator and Programmable Clock Output

ELECTRICAL CHARACTERISTICS (continued)

($V_{CC} = +12V$, $SEL1 = V_{CC}$, $SEL2 = DGND$, $R_{RT} = 124k\Omega$, $NDRV1 = NDRV2 = open$, $T_A = T_J = -40^{\circ}C$ to $+125^{\circ}C$, unless otherwise noted. Typical values are at $T_A = +25^{\circ}C$.) (Note 1)

PARAMETER	SYMBOL	CONDITIONS	MIN	TYP	MAX	UNITS
SEL_INPUTS						
Input Current		$0V \leq V_{SEL_} \leq V_{CC}$			1	μA
Input High Voltage	V_{IH}		3	2.5		V
Input Low Voltage	V_{IL}			2	1.5	V

Note 1: The MAX5077 is 100% tested at $T_A = T_J = +125^{\circ}C$. All limits over temperature are guaranteed by design.

Note 2: Use the following formula to calculate the MAX5077 oscillator frequency: $f_{OSC} = 10^{12} / (32 \times R_{RT})$.

Note 3: The accuracy of the oscillator's frequency is lower at frequencies greater than 1MHz.

Typical Operating Characteristics

($V_{CC} = +12V$, $SEL1 = V_{CC}$, $SEL2 = DGND$, $R_{RT} = 124k\Omega$, $NDRV1 = NDRV2 = open$, $CLK = open$.)

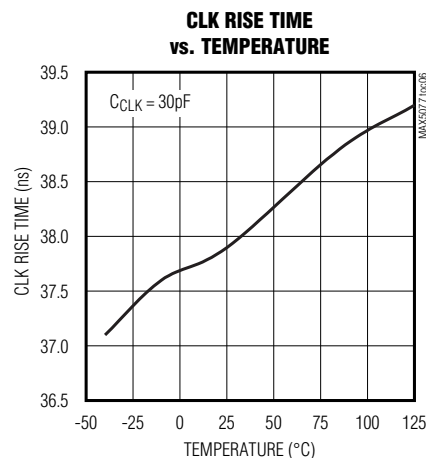
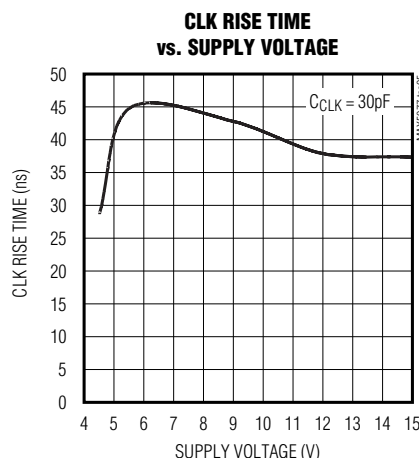
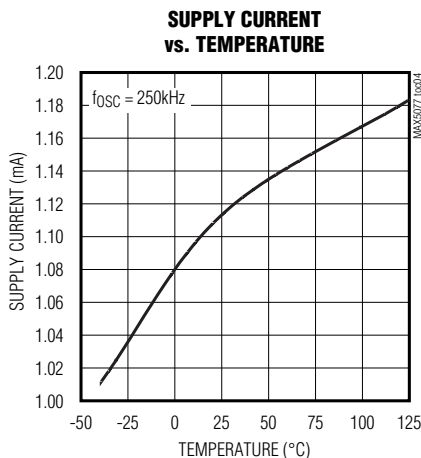
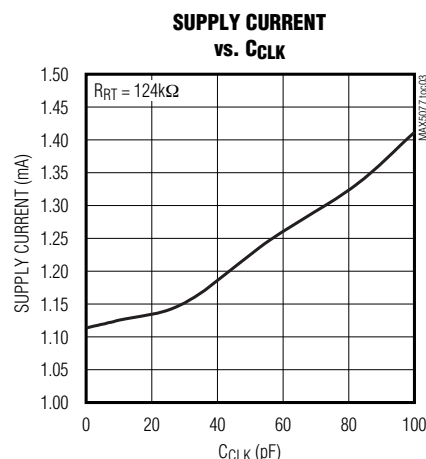
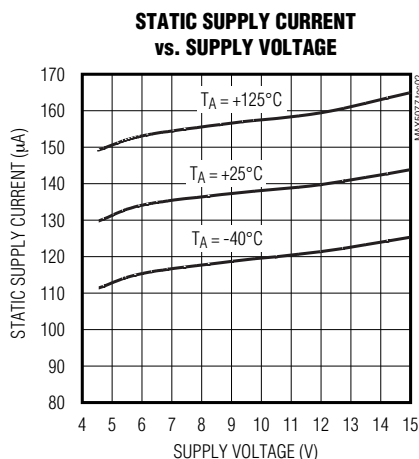
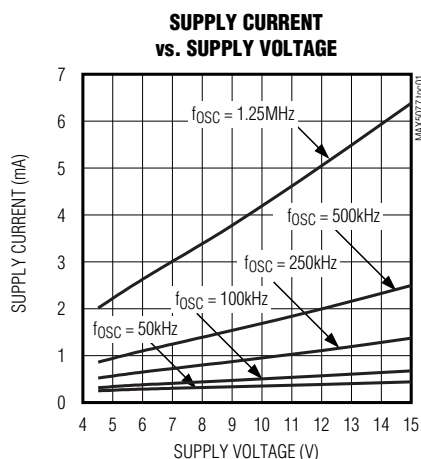

Push-Pull FET Driver with Integrated Oscillator and Programmable Clock Output

Typical Operating Characteristics (continued)

($V_{CC} = +12V$, $SEL1 = V_{CC}$, $SEL2 = DGND$, $R_{RT} = 124k\Omega$, $NDRV1 = NDRV2 = open$, $CLK = open$.)

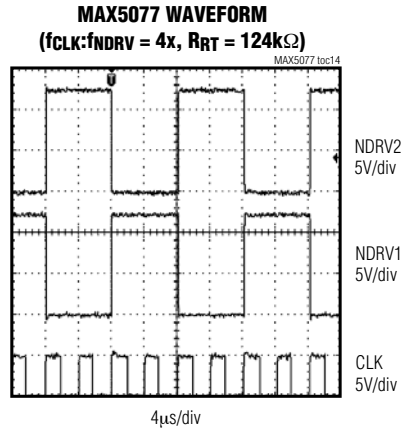
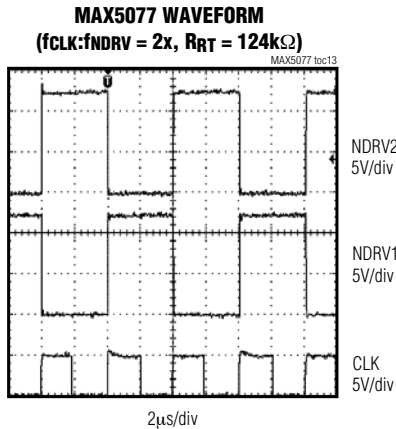
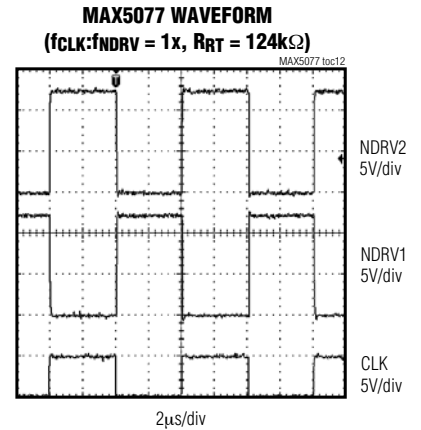
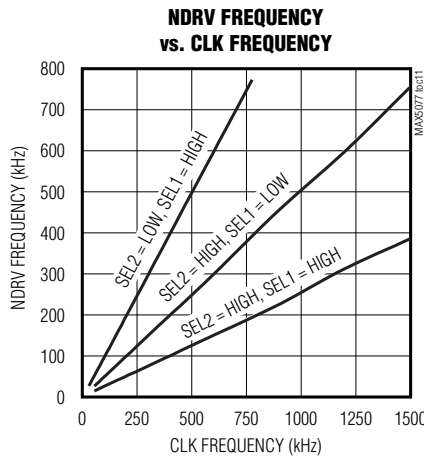
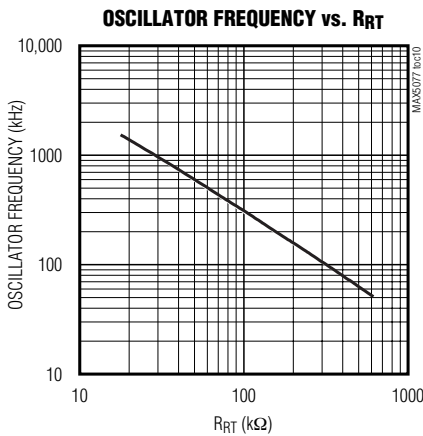
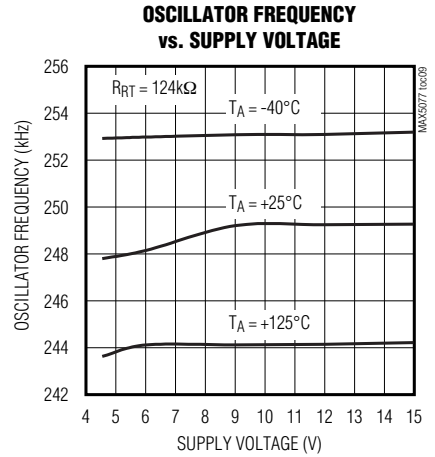
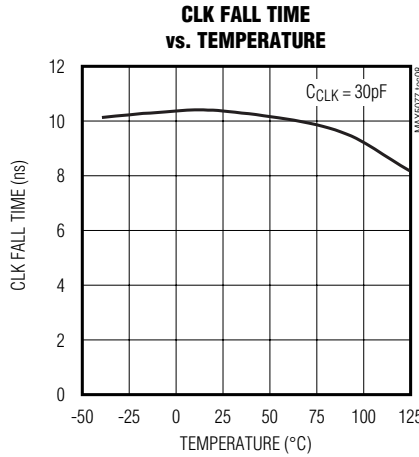
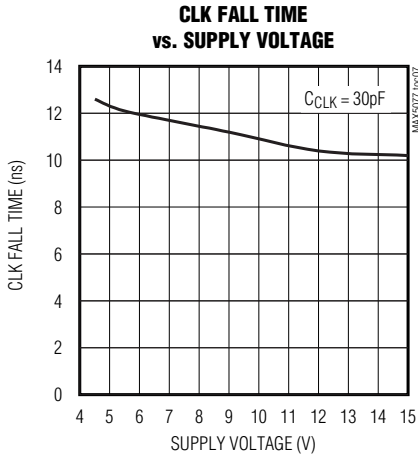

Push-Pull FET Driver with Integrated Oscillator and Programmable Clock Output

Pin Description

PIN	NAME	FUNCTION
1, 8	N.C.	No Connection. Must be left unconnected.
2	SEL1	CLK Frequency Ratio Select Input. Use SEL1 and SEL2 to set f_{CLK} to $f_{NDRV_}$ frequency ratio (see Table 1).
3	CLK	Synchronizing Clock Output. Clock output with a $\pm 10\text{mA}$ peak current drive that can be used to synchronize an external PWM regulator. CLK/NDRV_ frequency has a 1x, 2x, or 4x ratio (see the <i>Synchronizing Clock Output</i> section).
4, 14	I.C.	Connect to ground. Internal function.
5	RT	Oscillator Timing Resistor Connection. Bypass RT with a series of a $4.7\text{k}\Omega$ resistor and a 1nF capacitor to AGND. Connect a resistor from RT to AGND to set the internal oscillator frequency.
6	AGND	Analog Ground. Connect AGND to ground plane.
7	DGND	Digital Ground. Connect DGND to ground plane.
9	PGND	Power Ground. Connect to ground plane.
10	NDRV1	Gate Driver 1. Connect NDRV1 to the gate of an external n-channel FET.
11	NDRV2	Gate Driver 2. Connect NDRV2 to the gate of an external n-channel FET.
12	VCC	Power-Supply Input. Bypass VCC to PGND with $0.1\mu\text{F}/1\mu\text{F}$ ceramic capacitors.
13	SEL2	CLK Frequency Divisor Input. Use SEL1 and SEL2 to set f_{CLK} to $f_{NDRV_}$ frequency ratio (see Table 1).
EP	EP	Exposed Pad. Internally connected to DGND. Connect exposed pad to ground plane.

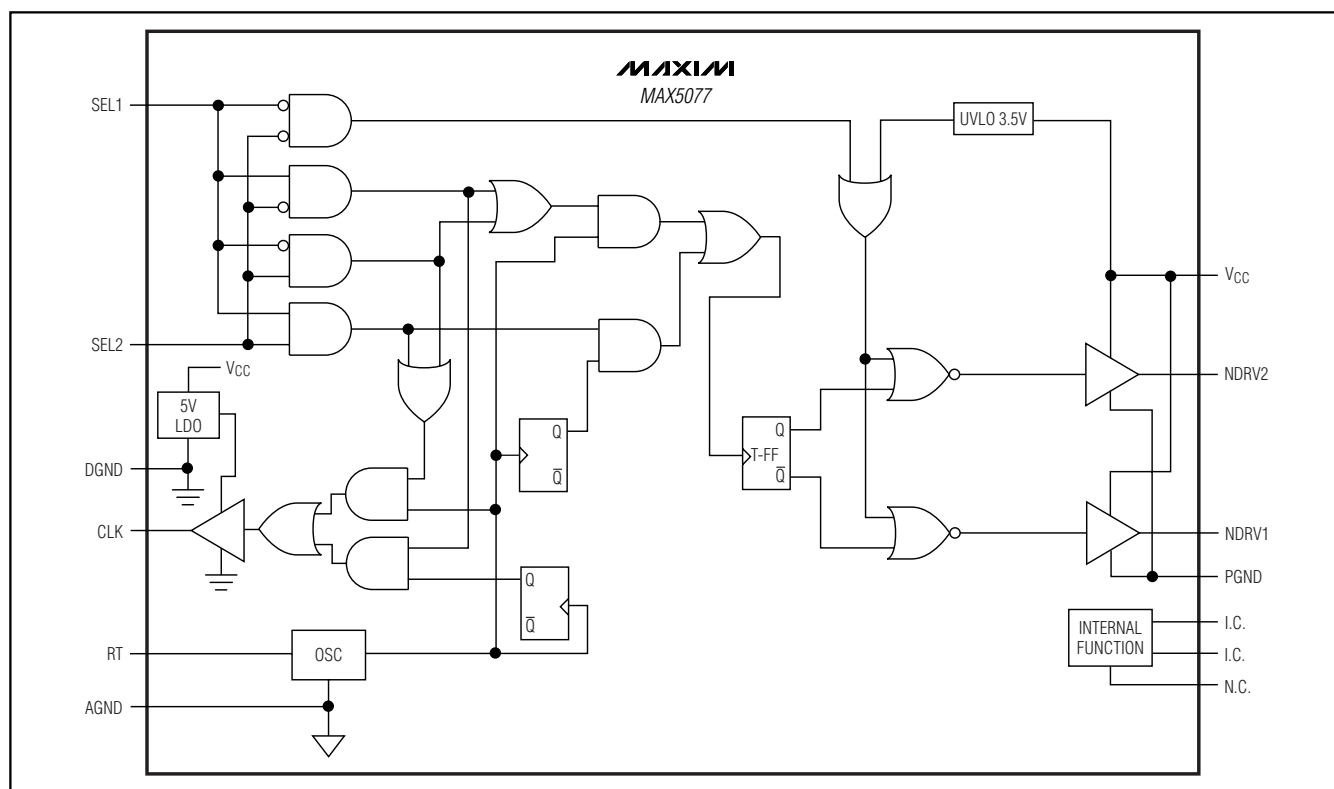

Figure 1. MAX5077 Functional Diagram

Push-Pull FET Driver with Integrated Oscillator and Programmable Clock Output

Detailed Description

The MAX5077 is a +4.5V to +15V push-pull, current-fed topology driver subsystem with an integrated oscillator for use in 48V module power supplies.

The MAX5077 features a programmable accurate integrated oscillator with a synchronizing clock output that can be used to synchronize an external PWM stage. A single external resistor programs the internal oscillator frequency from 50kHz to 1.5MHz.

The MAX5077 incorporates dual MOSFET drivers with $\pm 3A$ peak drive currents and a 50% duty cycle. The MOSFET drivers generate complementary signals to drive external ground-referenced n-channel MOSFETs.

The MAX5077 CLK output frequency is programmable through logic inputs that set the $f_{CLK}:f_{NDRV_}$ ratio to 1x, 2x, or 4x.

Internal Oscillator

An external resistor at RT programs the MAX5077's internal oscillator frequency from 50kHz to 1.5MHz. The MAX5077 NDRV1 and NDRV2 switching frequencies are one-half or one-fourth the programmed oscillator frequency with a nominal 50% duty cycle.

Use the following formula to calculate the internal oscillator frequency:

$$f_{OSC} = \frac{10^{12}}{32 \times R_{RT}}$$

where f_{OSC} is the oscillator frequency and R_{RT} is a resistor connected from RT to AGND in ohms.

Place a series combination of a 4.7k Ω resistor and a 1nF capacitor from RT to AGND for stability and to filter out noise.

When the $f_{CLK}:f_{NDRV_}$ ratio is set to 4, the NDRV1 and NDRV2 switching frequency is limited to one-fourth f_{OSC} . When operating the MAX5077 with the $f_{CLK}:f_{NDRV_}$ ratios set to 1 or 2 (see the *Synchronizing Clock Output* section), the NDRV1 and NDRV2 switching frequency is set to one-half f_{OSC} .

Synchronizing Clock Output

The MAX5077 provides a buffered clock output that can be used to synchronize the oscillator input of a PWM controller. CLK is powered from an internal 5V regulator and sources/sinks up to 10mA. Two logic inputs (SEL2, SEL1) select CLK output frequency to 1x, 2x, or 4x with respect to NDRV1 and NDRV2 switching frequency (see Table 1 and Figure 2). Drive SEL2 and SEL1 low to disable NDRV1, NDRV2, and CLK outputs. There is a typical 30ns delay from CLK to NDRV₁ output.

Table 1. CLK Output Frequency Selection

SEL2	SEL1	f _{CLK}	f _{NDRV₋}	f _{CLK} to f _{NDRV₋} RATIO
Low	Low	NDRV1, NDRV2, and CLK disabled		
Low	High	$f_{OSC} / 2$	$f_{OSC} / 2$	1
High	Low	f_{OSC}	$f_{OSC} / 2$	2
High	High	f_{OSC}	$f_{OSC} / 4$	4

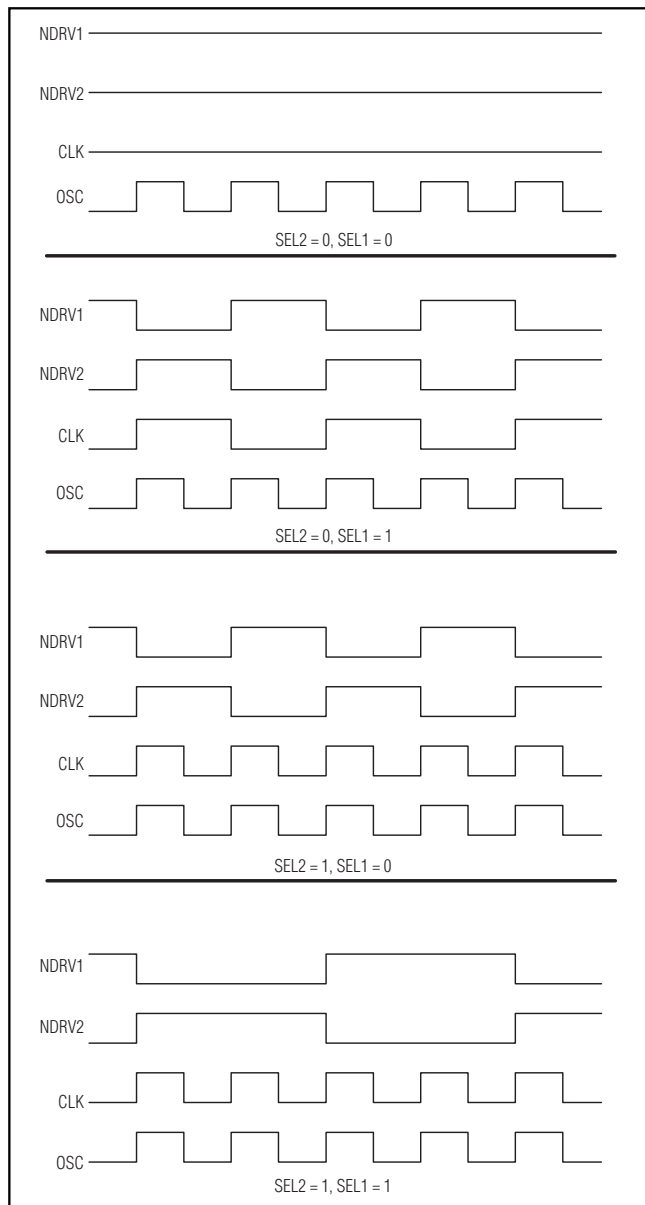

Figure 2. MAX5077 CLK Timing Diagram

Push-Pull FET Driver with Integrated Oscillator and Programmable Clock Output

Applications Information

Supply Bypassing

Pay careful attention to bypassing and grounding the MAX5077. Peak supply and output currents may exceed 3A when driving large MOSFETs. Ground shifts due to insufficient device grounding may also disturb other circuits sharing the same ground-return path. Any series inductance in the V_{CC} , NDRV1, NDRV2, and/or GND paths can cause noise due to the very high di/dt when switching the MAX5077 with any capacitive load. Place one or more 0.1 μ F ceramic capacitors in parallel as close to the device as possible to bypass V_{CC} to PGND. Use a ground plane to minimize ground-return resistance and inductance. Place the external MOSFETs as close as possible to the MAX5077 to further minimize board inductance and AC path impedance.

Power Dissipation

Power dissipation of the MAX5077 is a function of the sum of the quiescent current and the output current (either capacitive or resistive load). Maintain the sum of the currents so the maximum power dissipation limit is not exceeded. The power dissipation (P_{DISS}) due to the quiescent switching supply current (I_{CCSW}) can be calculated as:

$$P_{DISS} = V_{CC} \times I_{CCSW}$$

For capacitive loads, use the following equation to estimate the power dissipation:

$$P_{LOAD} = 2 \times C_{LOAD} \times V_{CC}^2 \times f_{NDRV_}$$

where C_{LOAD} is the capacitive load at NDRV1 and NDRV2, V_{CC} is the supply voltage, and $f_{NDRV_}$ is the MAX5077 NDRV_ switching frequency.

Calculate the total power dissipation (P_T) as follows:

$$P_T = P_{DISS} + P_{LOAD}$$

Layout Recommendations

The MAX5077 drivers source and sink large currents that can create very fast rise and fall edges at the gate of the switching MOSFETs. The high di/dt can cause unacceptable ringing if the trace lengths and impedances are not well controlled. Use the following PC board layout guidelines when designing with the MAX5077:

- Place one or more 0.1 μ F decoupling ceramic capacitors from V_{CC} to PGND as close to the device as possible. Connect V_{CC} and all ground pins to large copper areas. Place one bulk capacitor of 10 μ F on the PC board with a low-impedance path to the V_{CC} input and PGND of the MAX5077.
- Two AC current loops form between the device and the gates of the driven MOSFETs. The MOSFET looks like a large capacitance from gate to source when the gate pulls low. The current loop is from the MOSFET gate to NDRV1/NDRV2 of the MAX5077, to PGND, and to the source of the MOSFETs. When the gate of the MOSFET is pulled high, the current is from the V_{CC} terminal of the decoupling capacitor, to V_{CC} of the MAX5077, to NDRV1/NDRV2, to the MOSFET gate and source. Both charging current and discharging current loops are important. Minimize the physical distance and the impedance in these AC current paths.
- Keep the device as close to the MOSFET as possible.

Push-Pull FET Driver with Integrated Oscillator and Programmable Clock Output

Pin Configuration

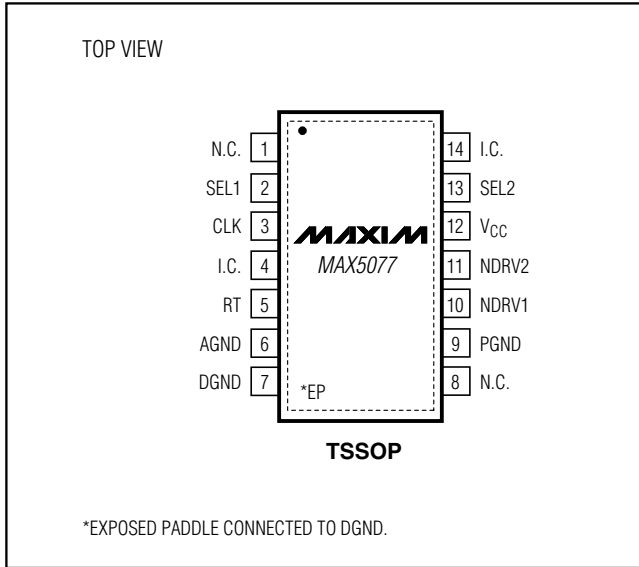

Chip Information

TRANSISTOR COUNT: 1335
PROCESS: BICMOS

Push-Pull FET Driver with Integrated Oscillator and Programmable Clock Output

Package Information

(The package drawing(s) in this data sheet may not reflect the most current specifications. For the latest package outline information go to www.maxim-ic.com/packages.)

MAX5077

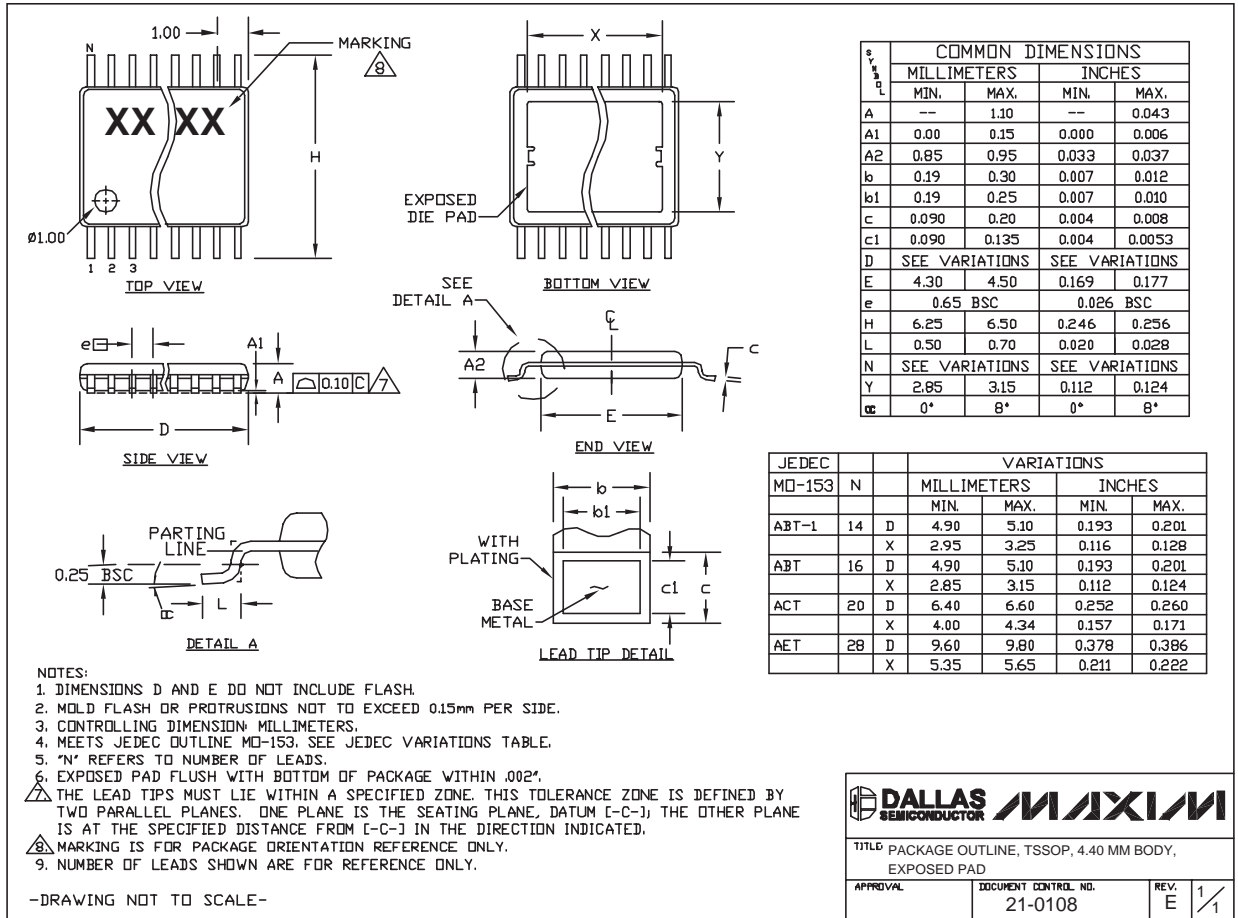

TSSOP 4.4mm BODY:EPS

Revision History

Pages changed at Rev 1: 1, 2, 5, 6, 9

Maxim cannot assume responsibility for use of any circuitry other than circuitry entirely embodied in a Maxim product. No circuit patent licenses are implied. Maxim reserves the right to change the circuitry and specifications without notice at any time.

Maxim Integrated Products, 120 San Gabriel Drive, Sunnyvale, CA 94086 408-737-7600 9

X-ON Electronics

Largest Supplier of Electrical and Electronic Components

Click to view similar products for [Gate Drivers](#) category:

Click to view products by [Maxim](#) manufacturer:

Other Similar products are found below :

[89076GBEST](#) [00053P0231](#) [56956](#) [57.404.7355.5](#) [LT4936](#) [57.904.0755.0](#) [5882900001](#) [00600P0005](#) [00-9050-LRPP](#) [00-9090-RDPP](#)
[5951900000](#) [01-1003W-10/32-15](#) [0131700000](#) [00-2240](#) [LTP70N06](#) [LVP640](#) [5J0-1000LG-SIL](#) [LY1D-2-5S-AC120](#) [LY2-US-AC240](#) [LY3-](#)
[UA-DC24](#) [00576P0020](#) [00600P0010](#) [LZN4-UA-DC12](#) [LZNQ2M-US-DC5](#) [LZNQ2-US-DC12](#) [LZP40N10](#) [00-8196-RDPP](#) [00-8274-RDPP](#)
[00-8275-RDNP](#) [00-8722-RDPP](#) [00-8728-WHPP](#) [00-8869-RDPP](#) [00-9051-RDPP](#) [00-9091-LRPP](#) [00-9291-RDPP](#) [0207100000](#) [0207400000](#)
[01312](#) [0134220000](#) [60713816](#) [M15730061](#) [61161-90](#) [61278-0020](#) [6131-204-23149P](#) [6131-205-17149P](#) [6131-209-15149P](#) [6131-218-17149P](#)
[6131-220-21149P](#) [6131-260-2358P](#) [6131-265-11149P](#)