



# +3V/+5V, 13-Bit, Serial Voltage-Output DACs with Internal Reference

## General Description

The MAX5130/MAX5131 are low-power, 13-bit, voltage-output digital-to-analog converters (DACs) with an internal precision bandgap reference and output amplifier. The MAX5130 operates on a single +5V supply with an internal reference of +2.5V, and is capable of a +4.0955V full-scale output. If necessary, the user can override the on-chip, <math><10\text{ppm}/^\circ\text{C}</math> voltage reference with an external reference. The MAX5131, operating on +3V, delivers its +2.04775V full-scale output with an internal precision reference of +1.25V. Both devices draw only 500 $\mu\text{A}$  of supply current, which reduces to 3 $\mu\text{A}$  in power-down mode. In addition, their power-up reset feature allows for a user-selectable initial output state of either 0V or midscale and minimizes output voltage glitches during power-up.

The serial interface is compatible with SPI™, QSPI™, and MICROWIRE™, which makes the MAX5130/MAX5131 suitable for cascading multiple devices. Each DAC has a double-buffered input organized as an input register followed by a DAC register. A 16-bit shift register loads data into the input register. The DAC register may be updated independently or simultaneously with the input register.

Both devices are available in a 16-pin QSOP package and are specified for the extended-industrial (-40°C to +85°C) temperature range. For pin-compatible 14-bit upgrades, see the MAX5170/MAX5172 data sheet; for pin-compatible 12-bit versions, see the MAX5120/MAX5121 data sheet.

## Applications

Industrial Process Control  
Automatic Test Equipment (ATE)  
Digital Offset and Gain Adjustment  
Motion Control  
 $\mu\text{P}$ -Controlled Systems

## Pin Configuration

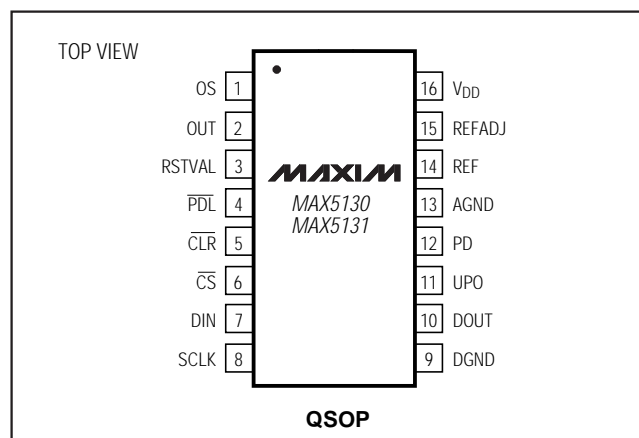

## Features

- ◆ **Single-Supply Operation**  
+5V (MAX5130)  
+3V (MAX5131)
- ◆ **Full-Scale Output Range**  
+4.0955V (MAX5130)  
+2.04775V (MAX5131)
- ◆ **Built-In 10ppm/°C (max) Precision Bandgap Reference**  
+2.5V (MAX5130)  
+1.25V (MAX5131)
- ◆ **Adjustable Output Offset**
- ◆ **SPI/QSPI/MICROWIRE-Compatible, 3-Wire Serial Interface**
- ◆ **Pin-Programmable Shutdown Mode and Power-Up Reset (0V or Midscale Output Voltage)**
- ◆ **Buffered Output Capable of Driving 5k $\Omega$  || 100pF or 4–20mA Loads**
- ◆ **Space-Saving 16-Pin QSOP Package**
- ◆ **Pin-Compatible Upgrades to the 12-Bit MAX5120/MAX5121**
- ◆ **Pin-Compatible 14-Bit Upgrades Available (MAX5170/MAX5172)**

## Ordering Information

PART	TEMP. RANGE	PIN-PACKAGE	INL (LSB)
MAX5130AEEE	-40°C to +85°C	16 QSOP	$\pm 0.5$
MAX5130BEEE	-40°C to +85°C	16 QSOP	$\pm 1$
MAX5131AEEE	-40°C to +85°C	16 QSOP	$\pm 1$
MAX5131BEEE	-40°C to +85°C	16 QSOP	$\pm 2$

SPI and QSPI are trademarks of Motorola, Inc.

MICROWIRE is a trademark of National Semiconductor Corp.



Maxim Integrated Products 1

For free samples & the latest literature: <http://www.maxim-ic.com>, or phone 1-800-998-8800.  
For small orders, phone 1-800-835-8769.

# +3V/+5V, 13-Bit, Serial Voltage-Output DACs with Internal Reference

## ABSOLUTE MAXIMUM RATINGS

V <sub>DD</sub> to AGND, DGND	-0.3V to +6V	Maximum Current into Any Pin	50mA
AGND to DGND	-0.3V to +0.3V	Continuous Power Dissipation (T <sub>A</sub> = +70°C)	
Digital Inputs to DGND	-0.3V to +6V	OSOP (derate 8.00mW/°C above +70°C)	667mW
Digital Outputs (DOUT, UPO) to DGND	-0.3V to (V <sub>DD</sub> + 0.3V)	Operating Temperature Range	-40°C to +85°C
OUT to AGND	-0.3V to (V <sub>DD</sub> + 0.3V)	Storage Temperature Range	-65°C to +150°C
OS to AGND	(AGND - 4V) to (V <sub>DD</sub> + 0.3V)	Lead Temperature (soldering, 10sec)	+300°C
REF, REFADJ to AGND	-0.3V to (V <sub>DD</sub> + 0.3V)		

Stresses beyond those listed under "Absolute Maximum Ratings" may cause permanent damage to the device. These are stress ratings only, and functional operation of the device at these or any other conditions beyond those indicated in the operational sections of the specifications is not implied. Exposure to absolute maximum rating conditions for extended periods may affect device reliability.

## ELECTRICAL CHARACTERISTICS—MAX5130 (+5V)

(V<sub>DD</sub> = +5V ±10%, OS = AGND = DGND = 0V, 33nF capacitor at REFADJ, internal reference, R<sub>L</sub> = 5kΩ, C<sub>L</sub> = 100pF, T<sub>A</sub> = T<sub>MIN</sub> to T<sub>MAX</sub>, unless otherwise noted. Typical values are at T<sub>A</sub> = +25°C.)

PARAMETER	SYMBOL	CONDITIONS	MIN	TYP	MAX	UNITS
<b>STATIC PERFORMANCE</b>						
Resolution	N		13			Bits
Integral Nonlinearity (Note 1)	INL	MAX5130A	-0.5		0.5	LSB
		MAX5130B	-1		1	
Differential Nonlinearity	DNL		-1		1	LSB
Offset Error (Note 2)	V <sub>OS</sub>		-10		10	mV
Gain Error	GE		-3	-0.2	3	mV
Full-Scale Voltage	V <sub>FS</sub>	Code = 1FFF hex, T <sub>A</sub> = +25°C	4.0463	4.0955	4.1447	V
Full-Scale Temperature Coefficient (Note 3)	TCV <sub>FS</sub>	MAX5130A		3	30	ppm/°C
		MAX5130B		10	50	
Power-Supply Rejection Ratio	PSRR	4.5V ≤ V <sub>DD</sub> ≤ 5.5V		20	250	μV/V
<b>REFERENCE</b>						
Output Voltage	V <sub>REF</sub>	T <sub>A</sub> = +25°C		2.5		V
Output Voltage Temperature Coefficient	TCV <sub>REF</sub>	MAX5130A		16		ppm/°C
		MAX5130B		24		
Reference External Load Regulation	V <sub>OUT</sub> /I <sub>OUT</sub>	0 ≤ I <sub>OUT</sub> ≤ 100μA (sourcing)		0.1	1	μV/μA
Reference Short-Circuit Current				4		mA
REFADJ Current		REFADJ = V <sub>DD</sub>		3.3	7	μA
<b>DIGITAL INPUT</b>						
Input High Voltage	V <sub>IH</sub>		3			V
Input Low Voltage	V <sub>IL</sub>				0.8	V
Input Hysteresis	V <sub>HYS</sub>			200		mV
Input Leakage Current	I <sub>IN</sub>	V <sub>IN</sub> = 0 or V <sub>DD</sub>	-1	0.001	1	μA
Input Capacitance	C <sub>IN</sub>			8		pF
<b>DIGITAL OUTPUTS</b>						
Output High Voltage	V <sub>OH</sub>	I <sub>SOURCE</sub> = 2mA	V <sub>DD</sub> - 0.5			V
Output Low Voltage	V <sub>OL</sub>	I <sub>SINK</sub> = 2mA		0.13	0.4	V

# +3V/+5V, 13-Bit, Serial Voltage-Output DACs with Internal Reference

MAX5130/MAX5131

## ELECTRICAL CHARACTERISTICS—MAX5130 (+5V) (continued)

( $V_{DD} = +5V \pm 10\%$ , OS = AGND = DGND = 0V, 33nF capacitor at REFADJ, internal reference,  $R_L = 5k\Omega$ ,  $C_L = 100pF$ ,  $T_A = T_{MIN}$  to  $T_{MAX}$ , unless otherwise noted. Typical values are at  $T_A = +25^\circ C$ .)

PARAMETER	SYMBOL	CONDITIONS	MIN	TYP	MAX	UNITS
<b>DYNAMIC PERFORMANCE</b>						
Voltage Output Slew Rate	SR			0.6		V/ $\mu$ s
Output Settling Time		To $\pm 0.5LSB$ , $V_{STEP} = 4V$		20		$\mu$ s
Output Voltage Swing (Note 4)				0 to $V_{DD}$		V
OS Input Resistance	$R_{OS}$		83	121		$k\Omega$
Time Required to Exit Shutdown				2		ms
Digital Feedthrough		$\overline{CS} = V_{DD}$ , $f_{SCLK} = 100kHz$ , $V_{SCLK} = 5Vp-p$		5		nV-s
<b>POWER REQUIREMENTS</b>						
Power-Supply Voltage (Note 5)	$V_{DD}$		4.5		5.5	V
Power-Supply Current (Note 5)	$I_{DD}$			500	600	$\mu$ A
Power-Supply Current in Shutdown	$I_{SHDN}$			3	20	$\mu$ A

## ELECTRICAL CHARACTERISTICS—MAX5131 (+3V)

( $V_{DD} = +3V \pm 10\%$ , OS = AGND = DGND = 0V, 33nF capacitor at REFADJ, internal reference,  $R_L = 5k\Omega$ ,  $C_L = 100pF$ ,  $T_A = T_{MIN}$  to  $T_{MAX}$ , unless otherwise noted. Typical values are at  $T_A = +25^\circ C$ .)

PARAMETER	SYMBOL	CONDITIONS	MIN	TYP	MAX	UNITS
<b>STATIC PERFORMANCE</b>						
Resolution	N		13			Bits
Integral Nonlinearity (Note 1)	INL	MAX5131A	-1		1	LSB
		MAX5131B	-2		2	
Differential Nonlinearity	DNL		-1		1	LSB
Offset Error (Note 2)	$V_{OS}$		-10		10	mV
Gain Error	GE	$R_L = \infty$	-5	-0.2	5	mV
Full-Scale Voltage	$V_{FS}$	Data = 1FFF hex, $T_A = +25^\circ C$	2.02317	2.04775	2.07232	V
Full-Scale Temperature Coefficient (Note 3)	$TCV_{FS}$	MAX5131A		3	10	ppm/ $^\circ C$
		MAX5131B		10	30	
Power-Supply Rejection Ratio	PSRR	$2.7V \leq V_{DD} \leq 3.3V$		20	250	$\mu$ V/V
<b>REFERENCE</b>						
Output Voltage	$V_{REF}$	$T_A = +25^\circ C$		1.25		V
Output Voltage Temperature Coefficient	$TCV_{REF}$	MAX5131A		3		ppm/ $^\circ C$
		MAX5131B		10		
Reference External Load Regulation	$V_{OUT}/I_{OUT}$	$0 \leq I_{OUT} \leq 100\mu A$ (sourcing)		0.1	1	$\mu$ V/ $\mu$ A
Reference Short-Circuit Current				4		mA
REFADJ Current		REFADJ = $V_{DD}$		3.3	7	$\mu$ A
<b>DIGITAL INPUT</b>						
Input High Voltage	$V_{IH}$		2.2			V
Input Low Voltage	$V_{IL}$				0.8	V
Input Hysteresis	$V_{HYS}$			200		mV

## +3V/+5V, 13-Bit, Serial Voltage-Output DACs with Internal Reference

### ELECTRICAL CHARACTERISTICS—MAX5131 (+3V) (continued)

( $V_{DD} = +3V \pm 10\%$ , OS = AGND = DGND = 0V, 33nF capacitor at REFADJ, internal reference,  $R_L = 5k\Omega$ ,  $C_L = 100pF$ ,  $T_A = T_{MIN}$  to  $T_{MAX}$ , unless otherwise noted. Typical values are at  $T_A = +25^\circ C$ .)

PARAMETER	SYMBOL	CONDITIONS	MIN	TYP	MAX	UNITS
Input Leakage Current	$I_{IN}$	$V_{IN} = 0$ or $V_{DD}$	-1	0.001	1	$\mu A$
Input Capacitance	$C_{IN}$			8		pF
<b>DIGITAL OUTPUTS</b>						
Output High Voltage	$V_{OH}$	$I_{SOURCE} = 2mA$	$V_{DD} - 0.5$			V
Output Low Voltage	$V_{OL}$	$I_{SINK} = 2mA$		0.13	0.4	V
<b>DYNAMIC PERFORMANCE</b>						
Voltage Output Slew Rate	SR			0.6		V/ $\mu s$
Output Settling Time		$T_O \pm 0.5LSB$ , $V_{STEP} = 2V$		20		$\mu s$
Output Voltage Swing (Note 4)				0 to $V_{DD}$		V
OS Input Resistance	$R_{OS}$		83	121		$k\Omega$
Time Required to Exit Shutdown				2		ms
Digital Feedthrough		$\overline{CS} = V_{DD}$ , $f_{SCLK} = 100kHz$ , $V_{SCLK} = 3Vp-p$		5		nV-s
<b>POWER REQUIREMENTS</b>						
Power-Supply Voltage (Note 5)	$V_{DD}$		2.7		3.6	V
Power-Supply Current (Note 5)	$I_{DD}$			500	60	$\mu A$
Power-Supply Current in Shutdown	$I_{SHDN}$			3	20	$\mu A$

### TIMING CHARACTERISTICS—MAX5130 (+5V)

( $V_{DD} = +5V \pm 10\%$ , OS = AGND = DGND = 0V, 33nF capacitor at REFADJ, internal reference,  $R_L = 5k\Omega$ ,  $C_L = 100pF$ ,  $T_A = T_{MIN}$  to  $T_{MAX}$ , unless otherwise noted. Typical values are at  $T_A = +25^\circ C$ .)

PARAMETER	SYMBOL	CONDITIONS	MIN	TYP	MAX	UNITS
SCLK Clock Period	$t_{CP}$		100			ns
SCLK Pulse Width High	$t_{CH}$		40			ns
SCLK Pulse Width Low	$t_{CL}$		40			ns
$\overline{CS}$ Fall to SCLK Rise Setup Time	$t_{CSS}$		40			ns
SCLK Rise to $\overline{CS}$ Rise Hold Time	$t_{CSH}$		0			ns
SDI Setup Time	$t_{DS}$		40			ns
SDI Hold Time	$t_{DH}$		0			ns
SCLK Rise to DOUT Valid Propagation Delay Time	$t_{DO1}$	$C_{LOAD} = 200pF$			80	ns
SCLK Fall to DOUT Valid Propagation Delay Time	$t_{DO2}$	$C_{LOAD} = 200pF$			80	ns
SCLK Rise to $\overline{CS}$ Fall Delay Time	$t_{CS0}$		10			ns
$\overline{CS}$ Rise to SCLK Rise Hold Time	$t_{CS1}$		40			ns
$\overline{CS}$ Pulse Width High	$t_{CSW}$		100			ns

# +3V/+5V, 13-Bit, Serial Voltage-Output DACs with Internal Reference

MAX5130/MAX5131

## TIMING CHARACTERISTICS—MAX5131 (+3V)

( $V_{DD} = +3V \pm 10\%$ , OS = AGND = DGND = 0V, 33nF capacitor at REFADJ, internal reference,  $R_L = 5k\Omega$ ,  $C_L = 100pF$ ,  $T_A = T_{MIN}$  to  $T_{MAX}$ , unless otherwise noted. Typical values are at  $T_A = +25^\circ C$ .)

PARAMETER	SYMBOL	CONDITIONS	MIN	TYP	MAX	UNITS
SCLK Clock Period	$t_{CP}$		150			ns
SCLK Pulse Width High	$t_{CH}$		75			ns
SCLK Pulse Width Low	$t_{CL}$		75			ns
$\overline{CS}$ Fall to SCLK Rise Setup Time	$t_{CSS}$		60			ns
SCLK Rise to $\overline{CS}$ Rise Hold Time	$t_{CSH}$		0			ns
SDI Setup Time	$t_{DS}$		60			ns
SDI Hold Time	$t_{DH}$		0			ns
SCLK Rise to DOUT Valid Propagation Delay Time	$t_{DO1}$	$C_{LOAD} = 200pF$			200	ns
SCLK Fall to DOUT Valid Propagation Delay Time	$t_{DO2}$	$C_{LOAD} = 200pF$			200	ns
SCLK Rise to $\overline{CS}$ Fall Delay Time	$t_{CS0}$		10			ns
$\overline{CS}$ Rise to SCLK Rise Hold Time	$t_{CS1}$		75			ns
$\overline{CS}$ Pulse Width High	$t_{CSW}$		150			ns

**Note 1:** Accuracy is guaranteed as shown in the following table:

$V_{DD}$ (V)	Accuracy Guaranteed	
	From Code:	To Code:
5	20	8191
3	40	8191

**Note 2:** Offset is measured at the code closest to 10mV.

**Note 3:** The temperature coefficient is determined by the "box" method in which the maximum  $\Delta V_{OUT}$  over the temperature range is divided by  $\Delta T$ .

**Note 4:** Accuracy is better than 1.0LSB for  $V_{OUT} = 10mV$  to  $(V_{DD} - 180mV)$ . Guaranteed by PSR test on end points.

**Note 5:**  $R_{LOAD} = \infty$  and digital inputs are at either  $V_{DD}$  or DGND.

## Typical Operating Characteristics

( $V_{DD} = +5V$  (MAX5130),  $V_{DD} = +3V$  (MAX5131),  $R_L = 5k\Omega$ ,  $C_L = 100pF$ , OS = AGND,  $T_A = +25^\circ C$ , unless otherwise noted.)

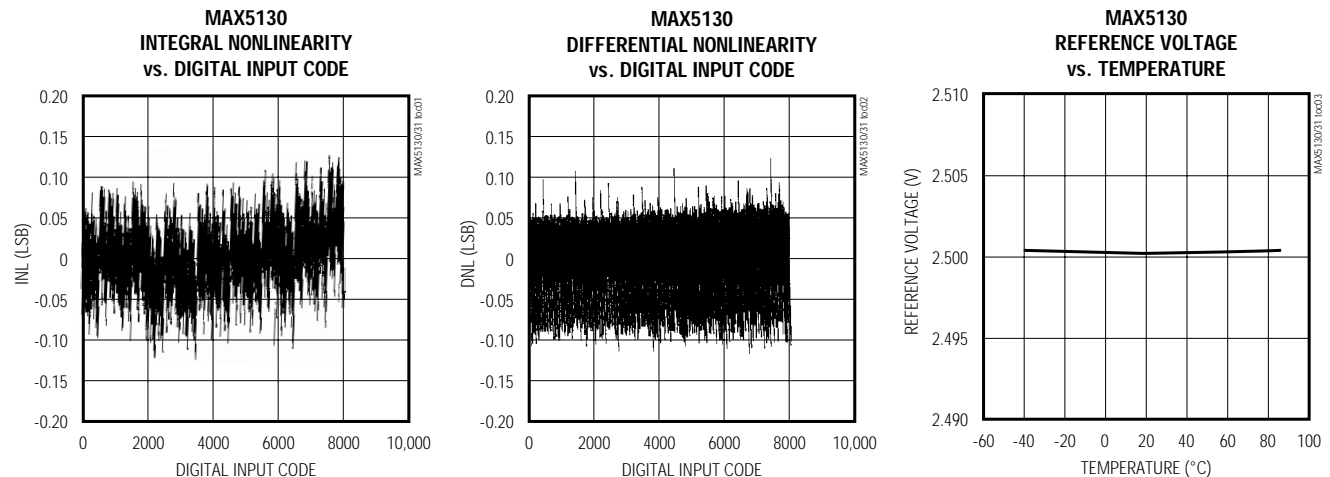

# +3V/+5V, 13-Bit, Serial Voltage-Output DACs with Internal Reference

## Typical Operating Characteristics (continued)

(V<sub>DD</sub> = +5V (MAX5130), V<sub>DD</sub> = +3V (MAX5131), R<sub>L</sub> = 5k $\Omega$ , C<sub>L</sub> = 100pF, OS = AGND, T<sub>A</sub> = +25°C, unless otherwise noted.)

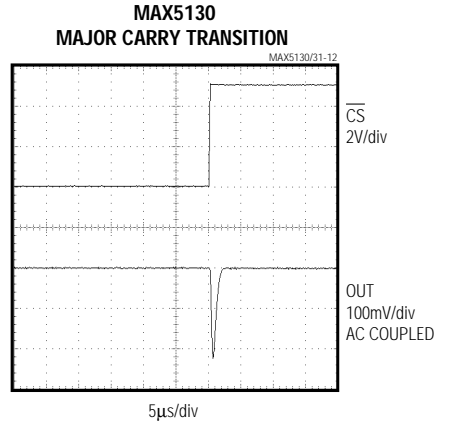
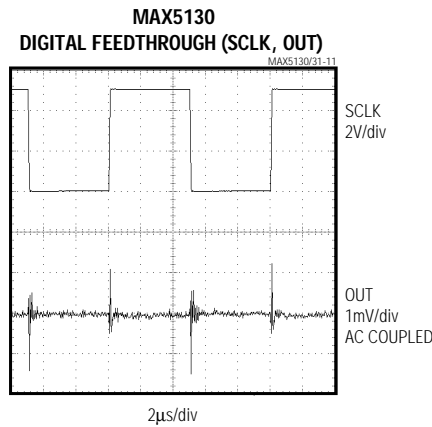
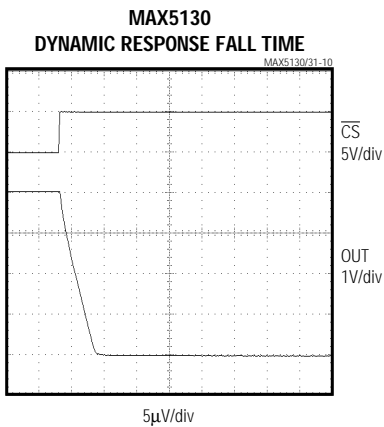
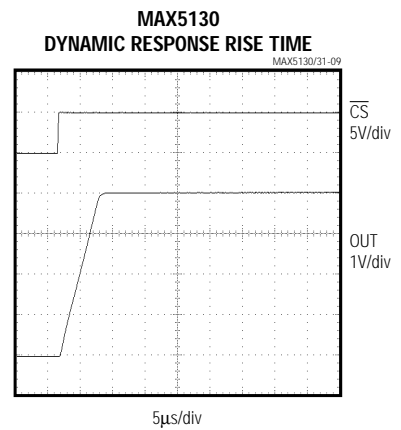
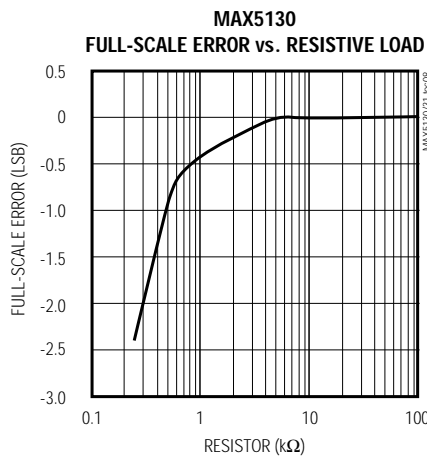
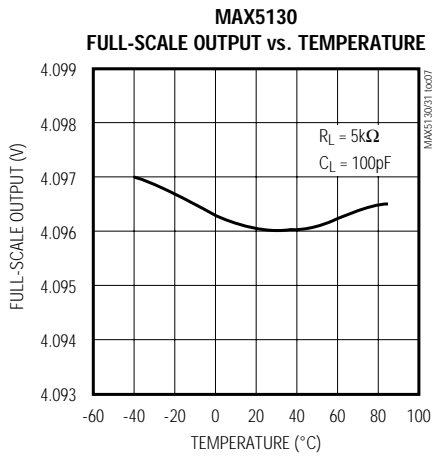
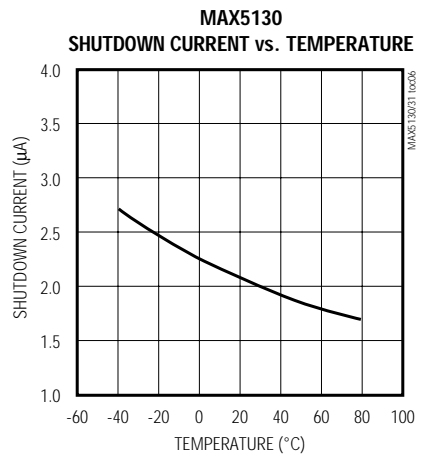
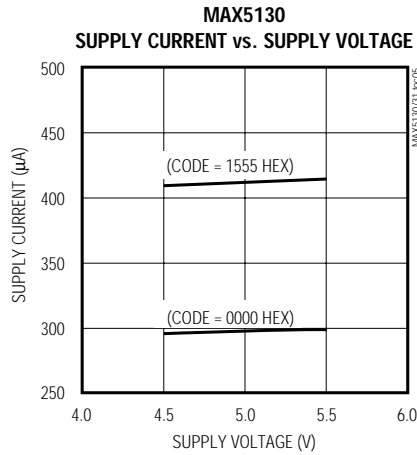
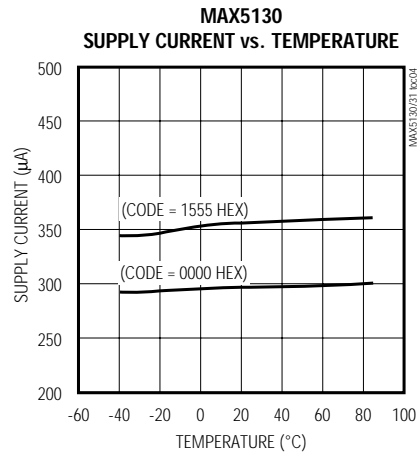

# +3V/+5V, 13-Bit, Serial Voltage-Output DACs with Internal Reference

## Typical Operating Characteristics (continued)

( $V_{DD} = +5V$  (MAX5130),  $V_{DD} = +3V$  (MAX5131),  $R_L = 5k\Omega$ ,  $C_L = 100pF$ , OS = AGND,  $T_A = +25^\circ C$ , unless otherwise noted.)

MAX5130/MAX5131

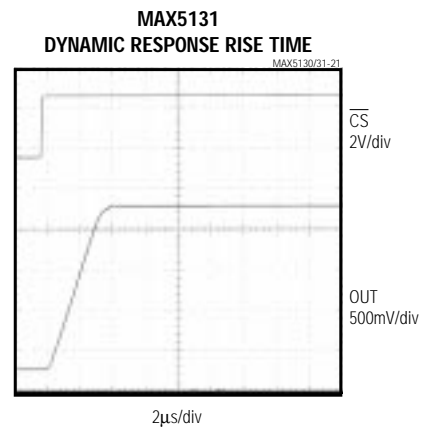
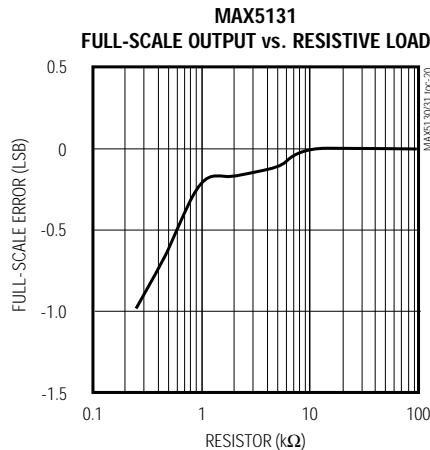
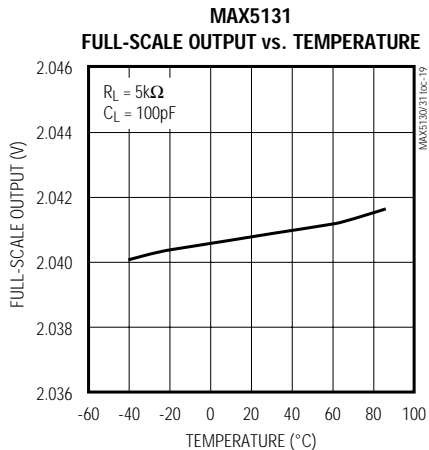
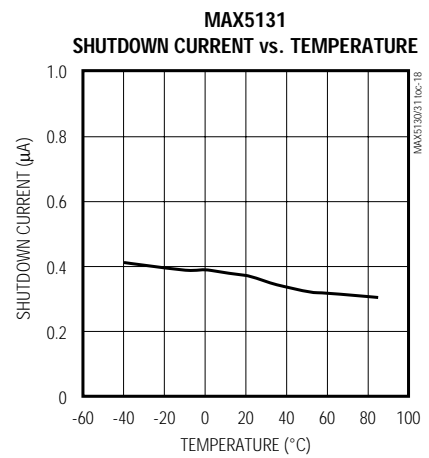
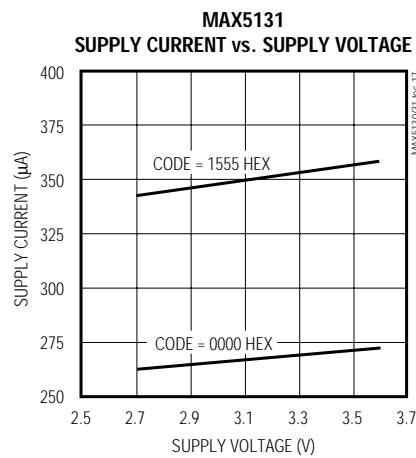
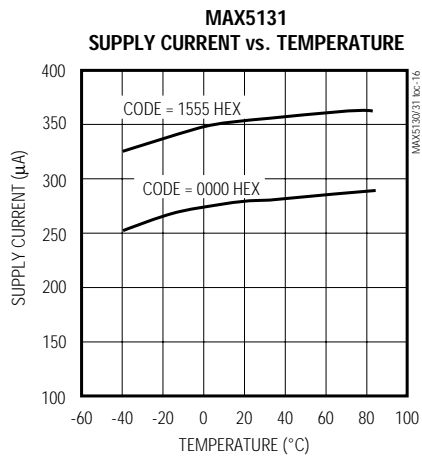
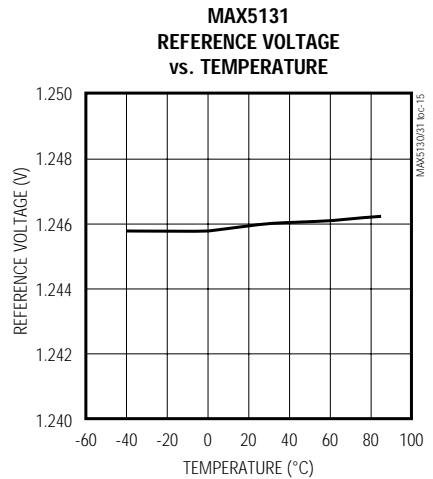
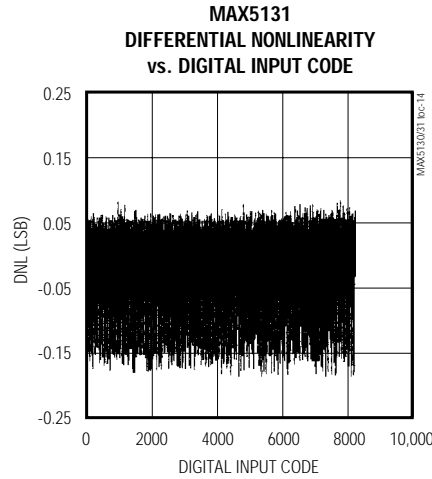
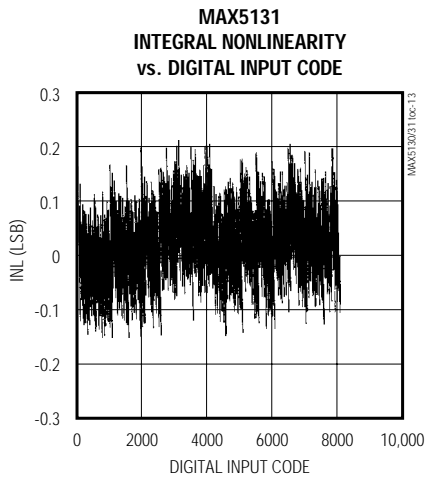

# +3V/+5V, 13-Bit, Serial Voltage-Output DACs with Internal Reference

## Typical Operating Characteristics (continued)

( $V_{DD} = +5V$  (MAX5130),  $V_{DD} = +3V$  (MAX5131),  $R_L = 5k\Omega$ ,  $C_L = 100pF$ ,  $OS = AGND$ ,  $T_A = +25^\circ C$ , unless otherwise noted.)

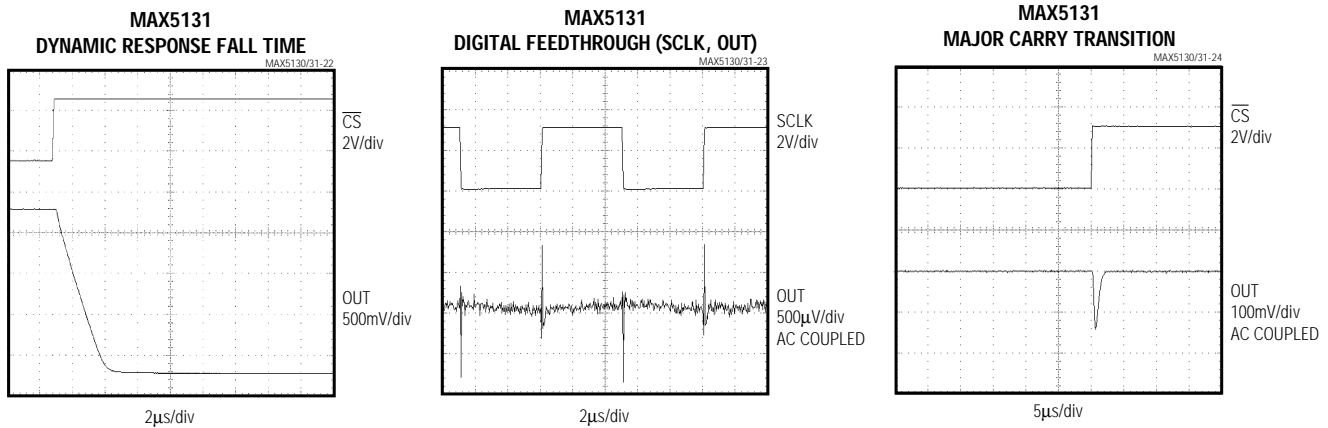

## Pin Description

PIN	NAME	FUNCTION
1	OS	Offset Adjust (Analog Input)
2	OUT	Analog Output Voltage. High impedance if part is in shutdown.
3	RSTVAL	Reset Value Input (Digital Input) 1: Tie to $V_{DD}$ to select midscale as the output reset value. 0: Tie to DGND to select 0V as the output reset value.
4	$\overline{PDL}$	Power-Down Lockout (Digital Input) 1: Normal operation. 0: Disallows shutdown (device cannot be powered down).
5	$\overline{CLR}$	Reset DAC Input (Digital Input). Clears the DAC to its predetermined (RSTVAL) output state. Clearing the DAC will cause it to exit a software shutdown state.
6	$\overline{CS}$	Active-Low Chip-Select Input (Digital Input)
7	DIN	Serial Data Input. Data is clocked in on the rising edge of SCLK.
8	SCLK	Serial Clock Input
9	DGND	Digital Ground
10	DOUT	Serial Data Output
11	UPO	User-Programmable Output (Digital Output)
12	PD	Power-Down Input (Digital Input). Pulling PD high when $\overline{PDL} = V_{DD}$ places the IC into shutdown with a maximum shutdown current of 20µA.
13	AGND	Analog Ground
14	REF	Buffered Reference Output/Input. In internal reference mode, the reference buffer provides a +2.5V (MAX5130) or +1.25V (MAX5131) nominal output, externally adjustable at REFADJ. In external reference mode, disable the internal reference by pulling REFADJ to $V_{DD}$ and applying the external reference to REF.
15	REFADJ	Analog Reference Adjust Input. Bypass with a 33nF capacitor to AGND. Connect to $V_{DD}$ when using an external reference.
16	$V_{DD}$	Positive Power Supply. Bypass with a 0.1µF capacitor in parallel with a 4.7µF capacitor to AGND.



# +3V/+5V, 13-Bit, Serial Voltage-Output DACs with Internal Reference

MAX5130/MAX5131

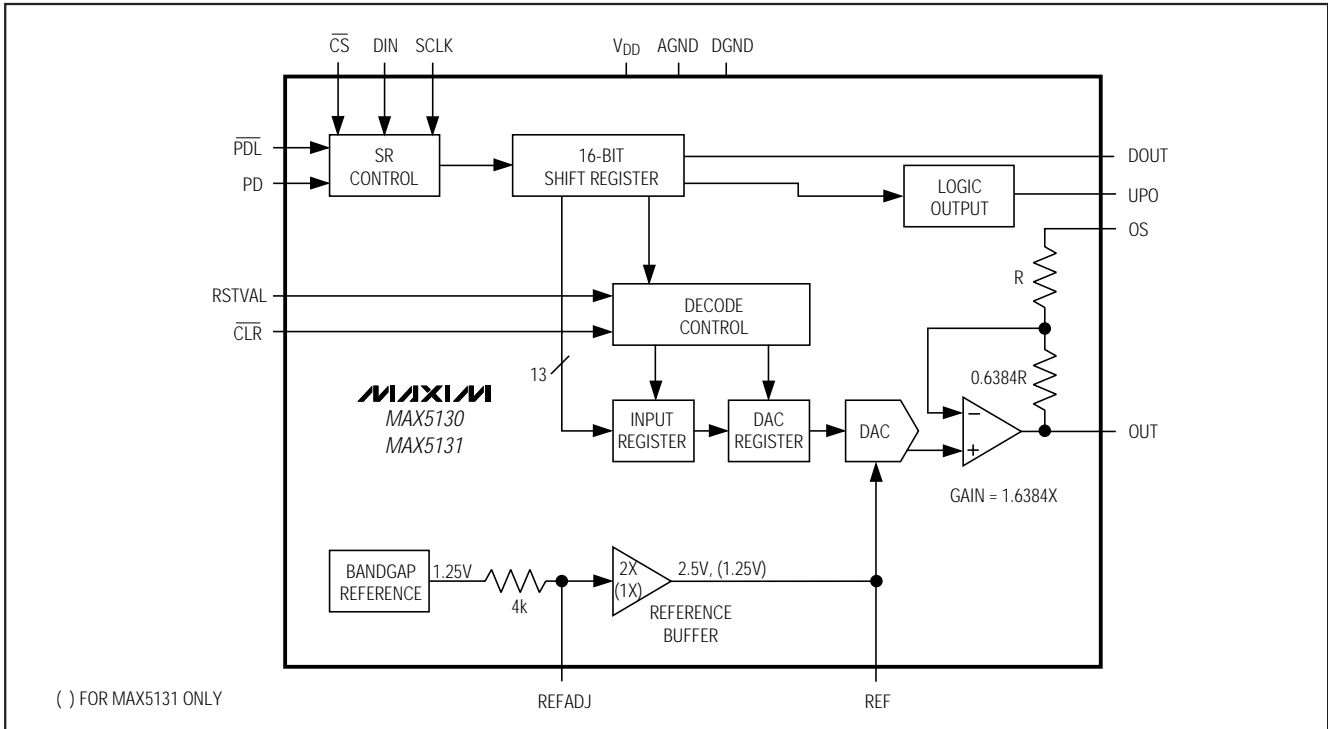

Figure 1. Simplified Functional Block Diagram

## Detailed Description

The MAX5130/MAX5131 13-bit, voltage-output DACs are easily configured with a 3-wire serial interface. They include a 16-bit data-in/data-out shift register and have a double-buffered input consisting of an input register and a DAC register. In addition, these devices employ precision bandgap references and trimmed internal resistors to produce a gain of 1.6384V/V, maximizing the output voltage swing (Figure 1). The MAX5130/MAX5131 output amplifier's offset-adjust pin allows for a DC shift in the DAC outputs. The full-scale output voltage is +4.0955V for the MAX5130 and +2.04775V for the MAX5131. These DACs are designed with an inverted R-2R ladder network (Figure 2) that produces a weighted output voltage proportional to the digital input code.

### Internal Reference

Both the MAX5130 and MAX5131 use an on-board precision bandgap reference to generate an output voltage of +2.5V (MAX5130) or +1.25V (MAX5131). With a low temperature coefficient of only 10ppm/°C (max), the REF pin can source up to 100µA and may become unstable with capacitive loads exceeding 100pF. REFADJ can be used for minor adjustments (1%) to the

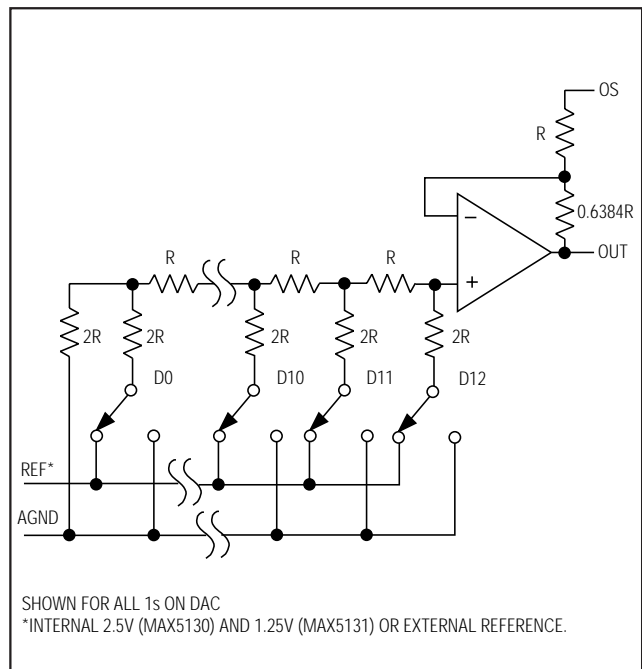

Figure 2. Simplified Inverted R-2R DAC Structure

## +3V/+5V, 13-Bit, Serial Voltage-Output DACs with Internal Reference

reference voltage. Use the circuits shown in Figure 3a (MAX5130) and Figure 3b (MAX5131) to achieve these adjustments. Connect a 33nF capacitor from REFADJ to AGND to establish low-noise operation of the DAC. Larger capacitor values may be used, but will result in increased start-up delay. The time constant ( $\tau$ ) for the start-up delay is determined by the REFADJ input impedance of 4k $\Omega$  and CREFADJ:

$$\tau = 4\text{k}\Omega \cdot \text{CREFADJ}$$

### External Reference

An external reference may be applied to the REF pin. Disable the internal reference by pulling REFADJ to VDD. This allows an external reference signal (AC- or DC-based) to be fed into the REF pin. For proper operation, **do not** exceed the input voltage range limits of 0V to (VDD - 1.4V) for VREF.

Determine the output voltage using the following equation (REFADJ = VDD; OS = AGND):

$$V_{\text{OUT}} = [V_{\text{REF}} \cdot (\text{NB} / 8192)] \cdot 1.6384\text{V/V}$$

where NB is the numeric value of the MAX5130/MAX5131 input code (0 to 8191), VREF is the external reference voltage, and 1.6384V/V is the gain of the internal output amplifier. The REF pin has a minimum input resistance of 40k $\Omega$  and is code-dependent.

### Output Amplifier

The output amplifier of the MAX5130/MAX5131 employs a trimmed resistor-divider to set a gain of +1.6384V/V and minimize the gain error. With its on-board laser-trimmed +1.25V reference and the output

buffer gain, the MAX5131 achieves a full-scale output of +2.04775V, while the MAX5130 provides a +4.0955V full-scale output with a +2.5V reference.

The output amplifier has a typical slew rate of 0.6V/ $\mu$ s and settles to  $\pm 0.5\text{LSB}$  within 20 $\mu$ s, with a load of 5k $\Omega$  in parallel with 100pF. Loads less than 1k $\Omega$  may result in degraded performance.

The OS pin may be used to adjust the output offset voltage. For instance, to achieve a +1V offset, apply -1.566V (Offset = -[Output Buffer Gain - 1]  $\cdot$  VOS) to OS to produce an output voltage range from +1V to (1V + VREF  $\cdot$  1.6384V/V). Note that the DAC's output range is still limited by the maximum output voltage specification.

### Power-Down Mode

The MAX5130/MAX5131 feature software- and hardware-programmable (PD pin) shutdown modes that reduce the typical supply current to 3 $\mu$ A. To enter software shutdown mode, program the control sequence for the DAC as shown in Table 1.

In shutdown mode, the amplifier output becomes high-impedance and the serial interface remains active. Data in the input registers is saved, allowing the MAX5130/MAX5131 to recall the output state prior to entering shutdown when returning to normal operation mode. To exit shutdown mode, load both input and DAC registers simultaneously or update the DAC register from the input register. When returning from shutdown mode, wait 2ms for the reference to settle. When using an external reference, the DAC requires only 20 $\mu$ s for the output to stabilize.

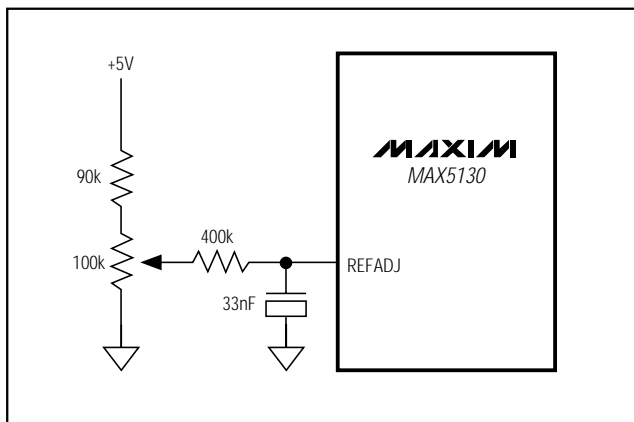

Figure 3a. MAX5130 Reference Adjust Circuit

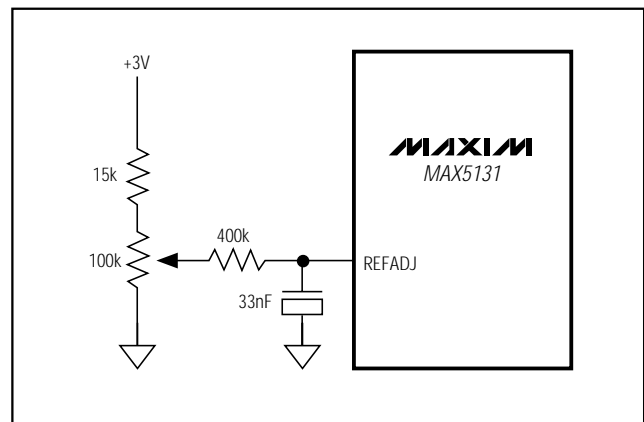

Figure 3b. MAX5131 Reference Adjust Circuit

# +3V/+5V, 13-Bit, Serial Voltage-Output DACs with Internal Reference

**Table 1. Serial-Interface Programming Commands**

16-BIT SERIAL WORD				FUNCTION
C2	C1	C0	D12 ..... D0	
0	0	0	XXXXXXXXXXXX	No operation.
0	0	1	13-Bit DAC Data	Load input register; DAC register unchanged.
0	1	0	13-Bit DAC Data	Simultaneously load input and DAC registers; exit shutdown.
0	1	1	XXXXXXXXXXXX	Update DAC register from input register; exit shutdown.
1	0	1	XXXXXXXXXXXX	Shutdown DAC (provided $\overline{PDL} = 1$ ).
1	0	0	XXXXXXXXXXXX	UPO goes low (default).
1	1	0	XXXXXXXXXXXX	UPO goes high.
1	1	1	1XXXXXXXXXXXX	Mode 1; DOUT clocked out on SCLK's rising edge.
1	1	1	0XXXXXXXXXXXX	Mode 0; DOUT clocked out on SCLK's falling edge (default).

X = Don't care

### Power-Down Lockout Input ( $\overline{PDL}$ )

The power-down lockout pin ( $\overline{PDL}$ ) disables shutdown when low. When in shutdown mode, a high-to-low transition on  $\overline{PDL}$  will wake up the DAC with its output still set to the state prior to power-down.  $\overline{PDL}$  can also be used to wake up the device asynchronously.

### Power-Down Input (PD)

Pulling PD high places the MAX5130/MAX5131 in shutdown mode. Pulling PD low will not return the MAX5130/MAX5131 to normal operation. A high-to-low transition on  $\overline{PDL}$  or appropriate commands (Table 1) via the serial interface are required to exit power-down.

### Serial-Interface Configuration (SPI/QSPI/MICROWIRE/PIC16/PIC17)

The MAX5130/MAX5131 3-wire serial interface is compatible with SPI, QSPI, PIC16/PIC17 (Figure 4) and MICROWIRE (Figure 5) interface standards. The 2-byte-long serial input word contains three control bits and 13 data bits in MSB-first format (Table 2).

The MAX5130/MAX5131's digital inputs are double buffered, which allows the user to:

- Load the input register without updating the DAC register,
- Update the DAC register with data from the input register,
- Update the input and DAC registers concurrently.

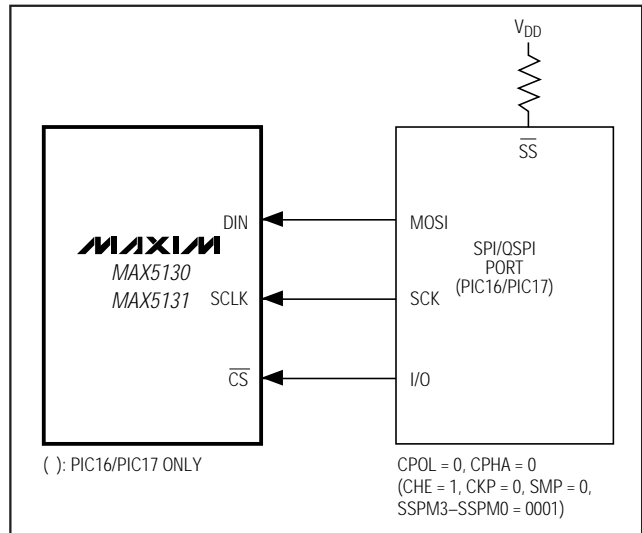

Figure 4. SPI/QSPI Interface Connections (PIC16/PIC17)

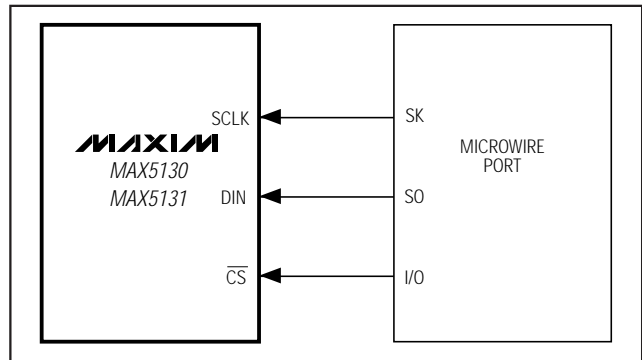

Figure 5. MICROWIRE Interface Connections

# +3V/+5V, 13-Bit, Serial Voltage-Output DACs with Internal Reference

The 16-bit input word may be sent in two 1-byte packets (SPI-, MICROWIRE- and PIC16/PIC17-compatible), with  $\overline{CS}$  low during this period. The control bits C2, C1, and C0 (Table 1) determine:

- The clock edge on which DOUT is to be clocked out via the serial interface,
- The state of the user-programmable logic output,
- The configuration of the device after shutdown.

The general timing diagram in Figure 6 illustrates how data is acquired.  $\overline{CS}$  must be low for the part to receive data. With  $\overline{CS}$  low, data at DIN is clocked into the register on the rising edge of SCLK. When  $\overline{CS}$  transitions high, data is latched into the input and/or DAC registers, depending on the setting of the three control bits C2, C1, and C0. The maximum serial clock frequency guaranteed for proper operation is 10MHz for the MAX5130 and 6.6MHz for the MAX5131. Figure 7 depicts a more detailed timing diagram of the serial interface.

## PIC16 with SSP Module and PIC17 Interface

The MAX5130/MAX5131 are compatible with a PIC16/PIC17 microcontroller ( $\mu C$ ), using the synchronous serial port (SSP) module. To establish SPI communication, connect the controller as shown in Figure 4 and configure the PIC16/PIC17 as system master by initializing its synchronous serial port control register (SSPCON) and synchronous serial port status register (SSPSTAT) to the bit patterns shown in Tables 3 and 4.

In SPI mode, the PIC16/PIC17  $\mu C$ s allow 8 bits of data to be transmitted synchronously and received simultaneously. Two consecutive 8-bit writings (Figure 6) are necessary to feed the DAC with three control bits and 13 data bits. DIN data transitions on the serial clock's falling edge and is clocked into the DAC on SCLK's rising edge. The first 8 bits on DIN contain the three control bits (C2, C1, and C0) and the first five data bits (D12–D8). The second 8-bit word contains the remaining bits (D7–D0).

**Table 2. Serial Data Format**

MSB ..... LSB	
← 16 BITS OF SERIAL DATA →	
Control Bits	MSB ..... Data Bits ..... LSB
C2, C1, C0	D12.....D0

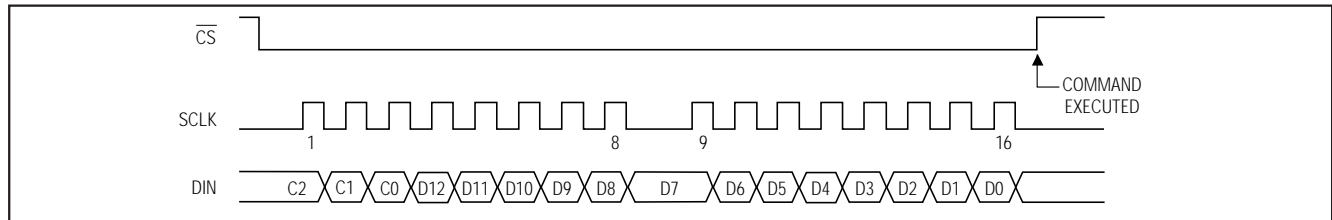

Figure 6. Serial-Interface Timing

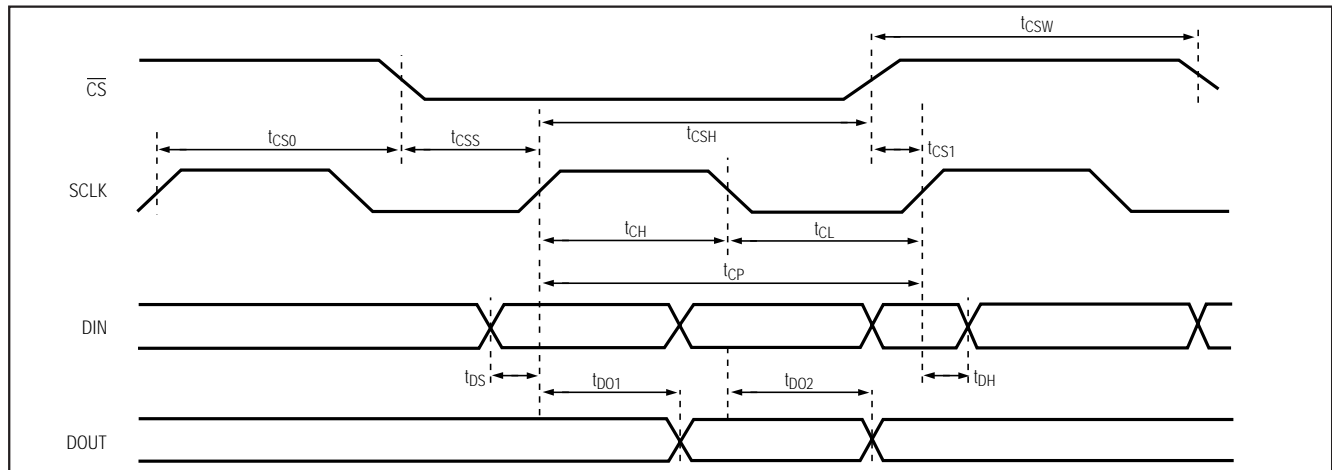

Figure 7. Detailed Serial-Interface Timing

# +3V/+5V, 13-Bit, Serial Voltage-Output DACs with Internal Reference

**Table 3. Detailed SSPCON Register Contents**

CONTROL BIT		MAX5130/MAX5131 SETTING	SYNCHRONOUS SERIAL-PORT CONTROL REGISTER (SSPCON)
WCOL	BIT7	X	Write Collision Detection Bit
SSPOV	BIT6	X	Receive Overflow Detection Bit
SSPEN	BIT5	1	Synchronous Serial Port Enable Bit 0: Disables serial port and configures these pins as I/O port pins. 1: Enables serial port and configures SCK, SDO and SCl as serial-port pins.
CKP	BIT4	0	Clock Polarity Select Bit. CKP = 0 for SPI master-mode selection.
SSPM3	BIT3	0	Synchronous Serial Port Mode Select Bit. Sets SPI master mode and selects $f_{CLK} = f_{OSC} / 16$ .
SSPM2	BIT2	0	
SSPM1	BIT1	0	
SSPM0	BIT0	1	

X = Don't care

**Table 4. Detailed SSPSTAT Register Contents**

CONTROL BIT		MAX5130/MAX5131 SETTINGS	SYNCHRONOUS SERIAL-PORT CONTROL REGISTER (SSPSTAT)
SMP	BIT7	0	SPI Data Input Sample Phase. Input data is sampled at the middle of the data output time.
CKE	BIT6	1	SPI Clock Edge Select Bit. Data will be transmitted on the rising edge of the serial clock.
D/A	BIT5	X	Data Address Bit
P	BIT4	X	Stop Bit
S	BIT3	X	Start Bit
R/W	BIT2	X	Read/Write Bit Information
UA	BIT1	X	Update Address
BF	BIT0	X	Buffer Full Status Bit

X = Don't care

### Serial Data Output

The contents of the internal shift register are output serially on DOUT, allowing for daisy-chaining (see *Applications Information*) of multiple devices as well as data readback. The MAX5130/MAX5131 may be programmed to shift data out on DOUT on the serial clock's rising edge (Mode 1) or falling edge (Mode 0). The latter is the default during power-up and provides a lag of 16 clock cycles, maintaining SPI, QSPI, MICROWIRE, and PIC16/PIC17 compatibility. In Mode 1, the output data lags DIN by 15.5 clock cycles. During power-down, DOUT retains its last digital state prior to shutdown.

### User-Programmable Output (UPO)

The UPO feature allows an external device to be controlled through the serial-interface setup (Table 1), thereby reducing the number of microcontroller I/O ports required. During power-down, this output will retain the last digital state before shutdown. With  $\overline{CLR}$  pulled low, UPO will reset to the default state after wake-up.

# +3V/+5V, 13-Bit, Serial Voltage-Output DACs with Internal Reference

## Applications Information

### Definitions

#### Integral Nonlinearity (INL)

Integral nonlinearity (Figure 8a) is the deviation of the values on an actual transfer function from a straight line. This straight line can be either a best-straight-line fit (closest approximation to the actual transfer curve) or a line drawn between the endpoints of the transfer function, once offset and gain errors have been nullified. For a DAC, the deviations are measured at every single step.

#### Differential Nonlinearity (DNL)

Differential nonlinearity (Figure 8b) is the difference between an actual step height and the ideal value of

1LSB. If the magnitude of the DNL is less than 1LSB, the DAC guarantees no missing codes and is monotonic.

#### Offset Error

The offset error (Figure 8c) is the difference between the ideal and the actual offset point. For a DAC, the offset point is the step value when the digital input is zero. This error affects all codes by the same amount and can usually be compensated for by trimming.

#### Gain Error

Gain error (Figure 8d) is the difference between the ideal and the actual full-scale output voltage on the transfer curve, after nullifying the offset error. This error alters the slope of the transfer function and corresponds to the same percentage error in each step.

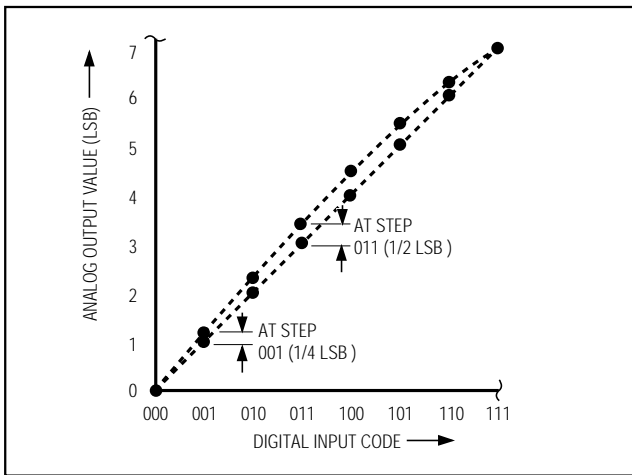

Figure 8a. Integral Nonlinearity

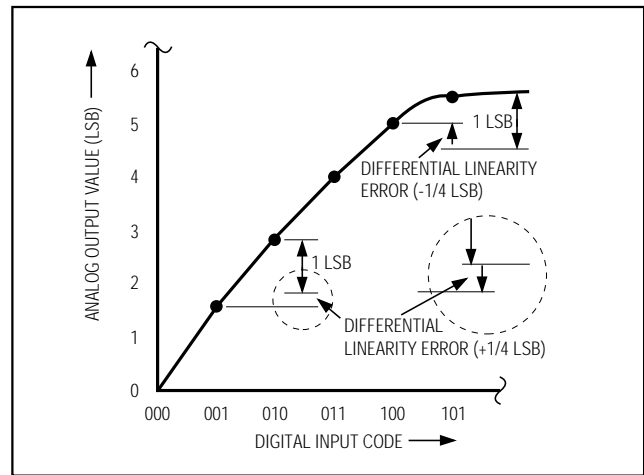

Figure 8b. Differential Nonlinearity

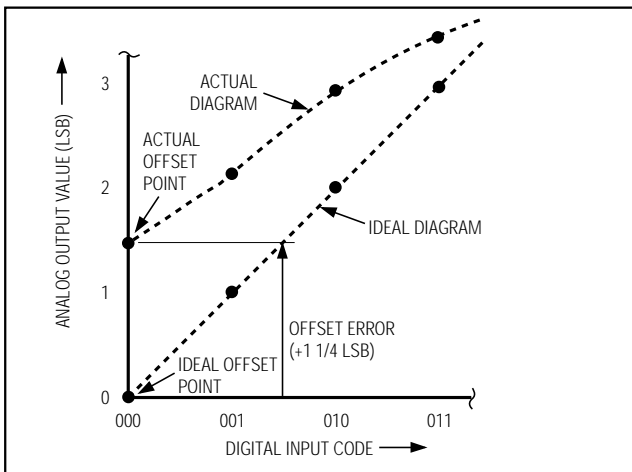

Figure 8c. Offset Error

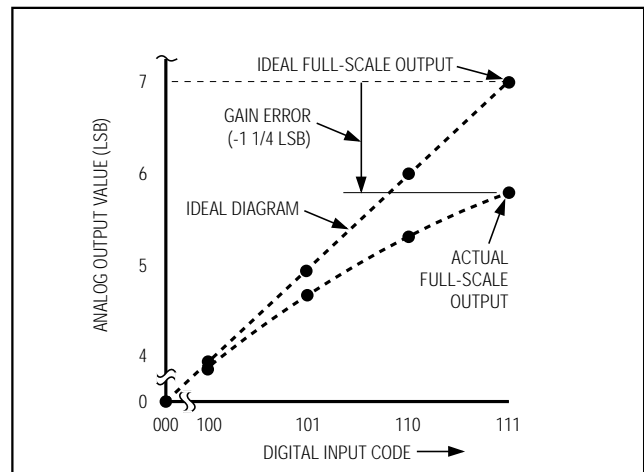

Figure 8d. Gain Error

# +3V/+5V, 13-Bit, Serial Voltage-Output DACs with Internal Reference

### Settling Time

The settling time is the amount of time required from the start of a transition until the DAC output settles to its new output value within the converter's specified accuracy.

### Digital Feedthrough

Digital feedthrough is noise generated on the DAC's output when any digital input transitions. Proper board layout and grounding will significantly reduce this noise, but there will always be some feedthrough caused by the DAC itself.

### Unipolar Output

Figure 9 shows the MAX5130/MAX5131 setup for unipolar, Rail-to-Rail® operation with a gain of 1.6384V/V. With its +2.5V internal reference, the MAX5130 can generate a unipolar output range of 0 to +4.0955V. The MAX5131 produces a range of 0 to +2.04775V with its on-board +1.25V reference. Table 5 lists example codes for unipolar output voltages. An offset to the output voltage can be achieved by simply connecting the appropriate voltage to the OS pin, as shown in Figure 10.

### Bipolar Output

The MAX5130/MAX5131 can be configured for unity-gain bipolar operation (OS = OUT) using the circuit shown in Figure 11. The output voltage  $V_{OUT}$  is thereby given by the following equation:

$$V_{OUT} = V_{REF} \cdot \{ [G \cdot (NB / 8192)] - 1 \}$$

where NB is the numeric value of the DAC's binary input code,  $V_{REF}$  is the voltage of the internal (or external) precision reference, and G is the overall gain. The application circuit in Figure 11 uses a low-cost operational amplifier (MAX4162) external to the MAX5130/MAX5131 in a unity-gain configuration. This provides an overall circuit gain of 2V/V. Table 6 lists example codes for bipolar output voltages.

### Reset (RSTVAL) and Clear (CLR) Functions

The MAX5130/MAX5131 DACs offer a clear pin ( $\overline{CLR}$ ), which resets the output to a certain value, depending upon how RSTVAL is set. RSTVAL = DGND sets the output to 0, and RSTVAL =  $V_{DD}$  sets the output to mid-scale when  $\overline{CLR}$  is pulled low.

The  $\overline{CLR}$  pin has a minimum input resistance of 40k $\Omega$  in series with a diode to the supply voltage ( $V_{DD}$ ). If the digital voltage is higher than the supply voltage for the part, a small input current may flow, but this current will be limited to  $(V_{\overline{CLR}} - V_{DD} - 0.5V) / 40k\Omega$ .

**Note:** Clearing the DAC will also cause the part to exit software shutdown (PD = 0).

Rail-to-Rail is a registered trademark of Nippon Motorola, Ltd.

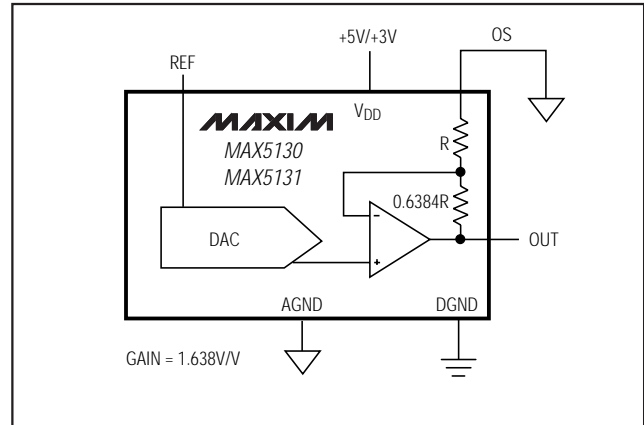

Figure 9. Unipolar Output Circuit (OS = AGND) Using Internal (+1.25V/+2.5V) or External Reference. With external reference, pull REFADJ to  $V_{DD}$ .

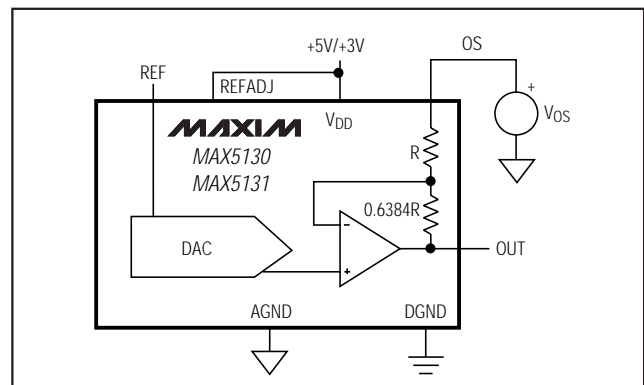

Figure 10. Circuit for Adding Offset to the DAC's Output

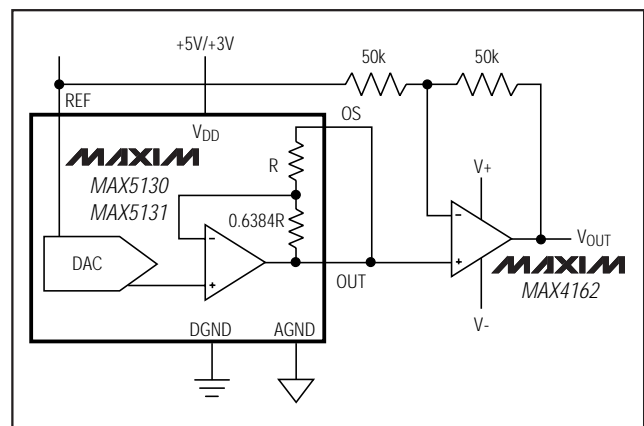

Figure 11. Unity-Gain Bipolar Output Circuit Using Internal (+1.25V/+2.5V) or External Reference. With external reference, pull REFADJ to  $V_{DD}$ .

# +3V/+5V, 13-Bit, Serial Voltage-Output DACs with Internal Reference

**Table 5. Unipolar Code Table (Gain = +1.6384V/V)**

DAC CONTENTS MSB      LSB		ANALOG OUTPUT		
		INTERNAL REFERENCE		EXTERNAL REFERENCE
		MAX5130	MAX5131	
1	1111 1111 1111	+4.0955V	+2.04775V	+VREF (8191 / 8192) • 1.6384
1	0000 0000 0001	+2.0485V	+1.02425V	+VREF (4097 / 8192) • 1.6384
1	0000 0000 0000	+2.0480V	+1.02400V	+VREF (4096 / 8192) • 1.6384
0	1111 1111 1111	+2.0475V	+1.02375V	+VREF (4095 / 8192) • 1.6384
0	0000 0000 0001	+0.5mV	+0.25mV	+VREF (1 / 8192) • 1.6384
0	0000 0000 0000	0V	0V	0V

**Table 6. Bipolar Code Table for Figure 11**

DAC CONTENTS MSB      LSB		ANALOG OUTPUT		
		INTERNAL REFERENCE		EXTERNAL REFERENCE
		MAX5130	MAX5131	
1	1111 1111 1111	+2.49939V	+1.24969V	VREF • [ {2 • (8191 / 8192)} - 1]
1	0000 0000 0001	+610.35µV	+305.18µV	VREF • [ {2 • (4097 / 8192)} - 1]
1	0000 0000 0000	0V	0V	VREF • [ {2 • (4096 / 8192)} - 1]
0	1111 1111 1111	-610.35µV	-305.18µV	VREF • [ {2 • (4095 / 8192)} - 1]
0	0000 0000 0001	-2.49939V	-1.24969V	VREF • [ {2 • (1 / 8192)} - 1]
0	0000 0000 0000	-2.5V	-1.25V	-VREF

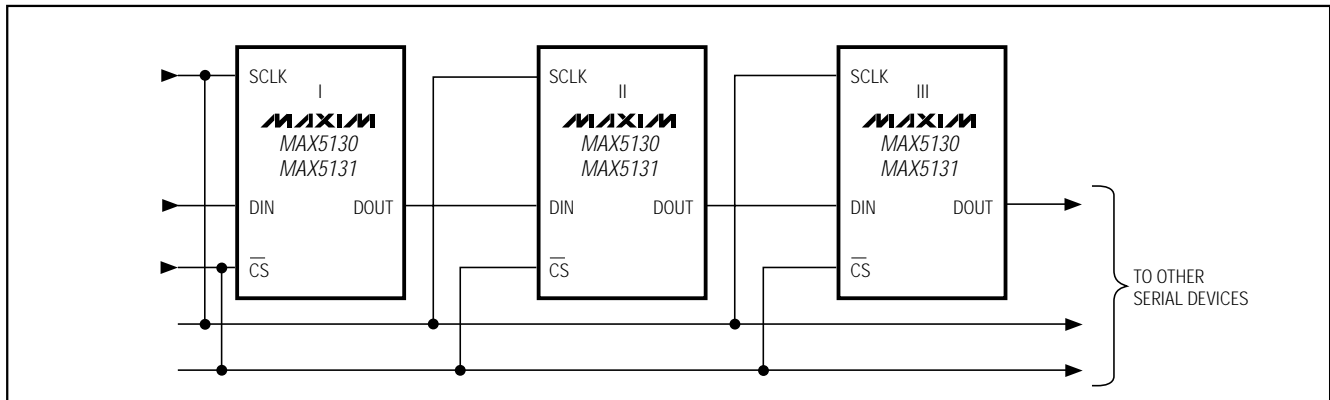

Figure 12. Daisy-Chaining Multiple Devices with the Digital I/Os DIN/DOUT

### Daisy-Chaining Devices

Any number of MAX5130/MAX5131s can be daisy-chained simply by connecting the serial data output pin (DOUT) of one device to the digital input pin (DIN) of the following device in the chain (Figure 12).

Another configuration allows several MAX5130/MAX5131 DACs to share one common DIN signal line (Figure 13). In this configuration, the data bus is common to all devices; data is not shifted through a daisy-chain. However, more I/O lines are required in this configuration, because each IC needs a dedicated CS line.



# +3V/+5V, 13-Bit, Serial Voltage-Output DACs with Internal Reference

## Using an External Reference with AC Components

The MAX5130/MAX5131 have multiplying capabilities within the reference input voltage range specifications. Figure 14 shows a technique for applying a sinusoidal input to REF, where the AC signal is offset before being applied to the reference input.

## Power-Supply and Bypassing Considerations

On power-up, the input and DAC registers are cleared to either zero (RSTVAL = DGND) or midscale (RSTVAL

=  $V_{DD}$ ). Bypass the power supply with a  $4.7\mu\text{F}$  capacitor in parallel with a  $0.1\mu\text{F}$  capacitor to AGND. Minimize lead lengths to reduce lead inductance.

## Layout Considerations

Digital and AC transient signals coupling to AGND can create noise at the output. Connect AGND to the highest quality ground available. Use proper grounding techniques, such as a multilayer board with a low-inductance ground plane. Wire-wrapped boards and sockets are not recommended. If noise becomes an issue, shielding may be required.

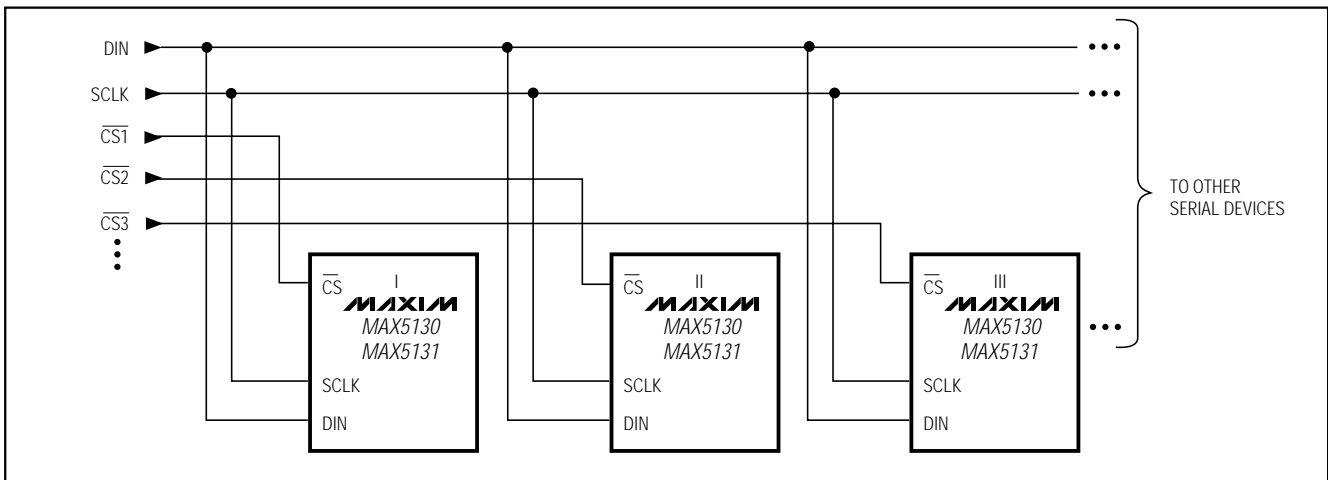

Figure 13. Multiple Devices Share One Common Digital Input (DIN)

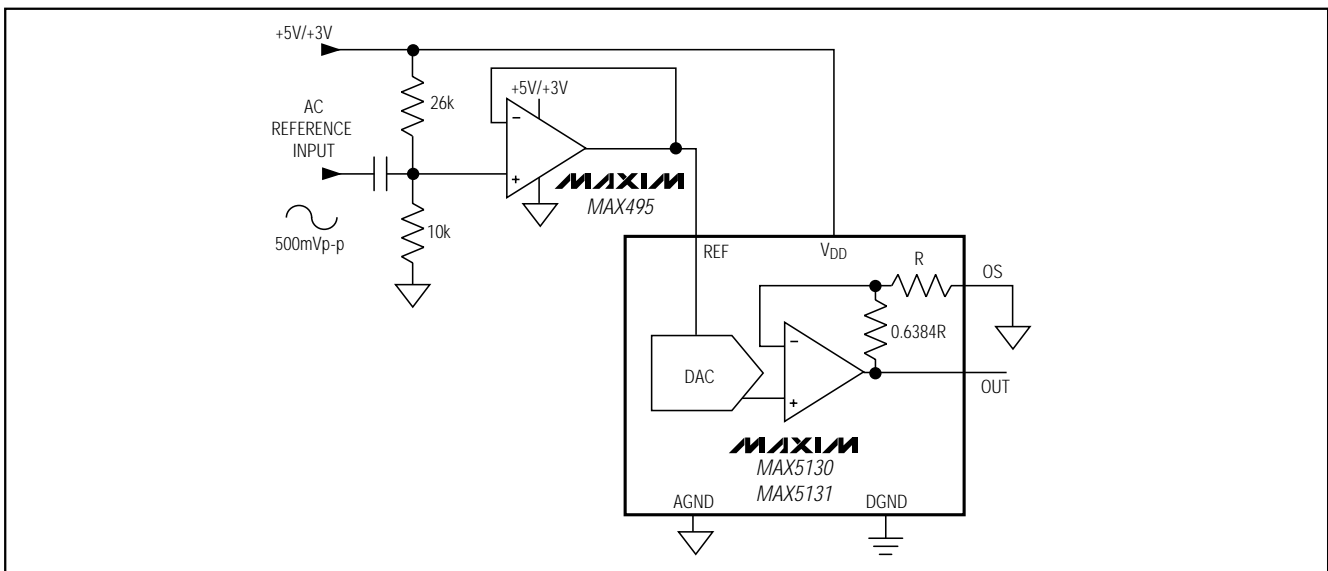

Figure 14. External Reference with AC Components

# +3V/+5V, 13-Bit, Serial Voltage-Output DACs with Internal Reference

## Chip Information

TRANSISTOR COUNT: 3308  
 SUBSTRATE CONNECTED TO AGND

## Package Information

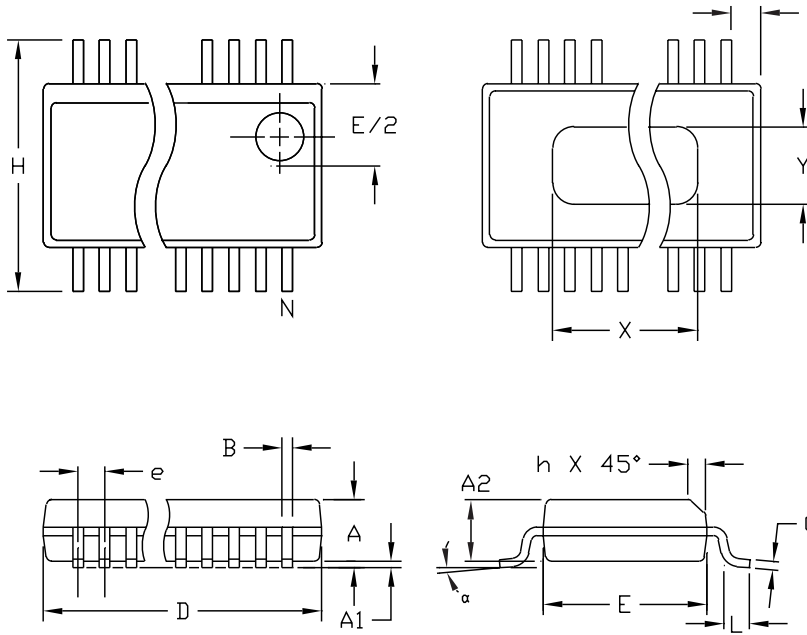

DIM	INCHES		MILLIMETERS	
	MIN	MAX	MIN	MAX
A	.061	.068	1.55	1.73
A1	.004	.0098	0.102	0.249
A2	.055	.061	1.40	1.55
B	.008	.012	0.20	0.31
C	.0075	.0098	0.191	0.249
D	SEE VARIATIONS			
E	.150	.157	3.81	3.99
e	.025 BSC		0.635 BSC	
H	.230	.244	5.84	6.20
h	.010	.016	0.25	0.41
L	.016	.035	0.41	0.89
N	SEE VARIATIONS			
X	SEE VARIATIONS			
Y	.071	.087	1.803	2.209
α	0°	8°	0°	8°

VARIATIONS:

DIM	INCHES		MILLIMETERS		N
	MIN.	MAX.	MIN.	MAX.	
D	.189	.196	4.80	4.98	16   AA
S	.0020	.0070	0.05	0.18	
X	.107	.123	2.72	3.12	
D	.337	.344	8.56	8.74	20   AB
S	.0500	.0550	1.270	1.397	
D	.337	.344	8.56	8.74	24   AC
S	.0250	.0300	0.635	0.762	
D	.386	.393	9.80	9.98	28   AD
S	.0250	.0300	0.635	0.762	
X	.271	.287	6.88	7.29	

- NOTES:
1. D & E DO NOT INCLUDE MOLD FLASH OR PROTRUSIONS
  2. MOLD FLASH OR PROTRUSIONS NOT TO EXCEED .006" PER SIDE.
  3. HEAT SLUG DIMENSIONS X AND Y APPLY ONLY TO 16 AND 28 LEAD POWER-QSOP PACKAGES.
  4. CONTROLLING DIMENSIONS: INCHES.

**MAXIM**  
 PROPRIETARY INFORMATION  
 TITLE: PACKAGE OUTLINE, QSOP, .150", .025" LEAD PITCH  
 APPROVAL: DOCUMENT CONTROL NO: 21-0055 REV: B 1/1

OSOP:EPS

*+3V/+5V, 13-Bit, Serial Voltage-Output DACs  
with Internal Reference*

NOTES

MAX5130/MAX5131

# +3V/+5V, 13-Bit, Serial Voltage-Output DACs with Internal Reference

## NOTES

*Maxim cannot assume responsibility for use of any circuitry other than circuitry entirely embodied in a Maxim product. No circuit patent licenses are implied. Maxim reserves the right to change the circuitry and specifications without notice at any time.*

**20** \_\_\_\_\_ Maxim Integrated Products, 120 San Gabriel Drive, Sunnyvale, CA 94086 408-737-7600

## X-ON Electronics

Largest Supplier of Electrical and Electronic Components

*Click to view similar products for [Digital to Analog Converters - DAC category](#):*

*Click to view products by [Maxim manufacturer](#):*

Other Similar products are found below :

[5962-8871903MYA](#) [5962-8876601LA](#) [AD5311BRMZ-REEL7](#) [AD664AJ](#) [AD7534JPZ](#) [TCC-103A-RT](#) [057536E](#) [5962-89657023A](#)  
[702423BB](#) [TCC-202A-RT](#) [AD664BE](#) [TCC-303A-RT](#) [TCC-206A-RT](#) [AD5770RBCBZ-RL7](#) [DAC8229FSZ-REEL](#) [AD5673RBCPZ-2](#)  
[MCP48FVB24-20E/ST](#) [MCP48FVB28-E/MQ](#) [MCP48FEB18-20E/ST](#) [MCP48FEB18-E/MQ](#) [MCP48FEB24-E/MQ](#) [MCP48FEB28T-20E/ST](#)  
[MCP47FVB04T-E/MQ](#) [MCP48FEB28T-E/MQ](#) [MCP48FVB28T-20E/ST](#) [MCP47FVB28T-20E/ST](#) [MCP47FEB24T-E/MQ](#) [MCP48FVB18T-](#)  
[20E/ST](#) [MCP47FEB14T-E/MQ](#) [MCP47FEB08T-E/MQ](#) [MCP48FVB08T-20E/ST](#) [MCP47FEB04T-E/MQ](#) [MCP47FVB04T-20E/ST](#)  
[AD7524JRZ-REEL](#) [LTC1664CGN](#) [LTC1664IGN](#) [LTC7545ACSW](#) [MCP47DA1T-A1E/OT](#) [MCP4921-E/MC](#) [UC3910D](#) [DAC39J84IAAV](#)  
[DAC8218SPAG](#) [DAC8562TDGSR](#) [MAX551ACUB+](#) [MAX545BCPD+](#) [MAX531BCPD+](#) [DAC7641YB/250](#) [DAC7611PB](#) [DAC0800LCM](#)  
[TLV5638CDR](#)