



MAX5389 Evaluation Kit

Evaluates: MAX5389

General Description

The MAX5389 evaluation kit (EV kit) is an assembled and tested PCB that features the MAX5389M 50k Ω dual digital potentiometer. The EV kit provides a mechanical pushbutton-controlled interface or a user-supplied digital interface for the IC digital inputs for changing the potentiometer wipers.

The EV kit operates from an external 2.8V to 5.5V power supply applied at the VIN and GND PCB pads. The MAX5389 operates from a 2.6V to 5.5V VDD supply. Additional LDO regulators are provided to operate the MAX5389 VDD input at 2.6V or 3.3V. The on-board regulators require a 200mV overhead above their respective outputs.

Features

- ◆ 2.8V to 5.5V Single-Supply Operation
- ◆ 2.6V or 3.3V MAX5389 VDD input
- ◆ Supports Pushbutton or Stand-Alone Digital Input Interfacing

Ordering Information

PART	TYPE
MAX5389EVKIT+	EV Kit

+Denotes lead(Pb)-free and RoHS compliant.

Component List

DESIGNATION	QTY	DESCRIPTION
C1, C3, C5	3	10 μ F \pm 10%, 6.3V X5R ceramic capacitors (0805) Murata GRM21BR60J106K TDK C2012X5R0J106K
C2, C4, C6	3	1 μ F \pm 10%, 16V X5R ceramic capacitors (0603) TDK C1608X5R1C105K
C7	1	0.1 μ F \pm 10%, 10V X7R ceramic capacitor (0603) Murata GRM188R71H104K TDK C1608X7R1H104K
C8	0	Not installed, ceramic capacitor (0603)
J1	1	2 x 8-pin header
JU1	1	4-pin header
JU2–JU11	10	2-pin headers
R1–R6	6	100k Ω \pm 5% resistors (0603)

DESIGNATION	QTY	DESCRIPTION
SW1–SW6	6	Momentary pushbutton switches
U1	1	Dual 50k Ω potentiometer (14 TSSOP) Maxim MAX5389MAUD+
U2	1	3.3V LDO regulator (5 SC70) Maxim MAX8511EXK33+ (Top Mark: AEI)
U3	1	2.6V LDO regulator (5 SC70) Maxim MAX8511EXK26+ (Top Mark: AEG)
U4	1	Octal switch debouncer (20 SSOP) Maxim MAX6818EAP+
—	11	Shunts (JU1–JU11)
—	1	PCB: MAX5389 EVALUATION KIT+

Component Suppliers

SUPPLIER	PHONE	WEBSITE
Murata Electronics North America, Inc.	770-436-1300	www.murata-northamerica.com
TDK Corp.	847-803-6100	www.component.tdk.com

Note: Indicate that you are using the MAX5389 when contacting these component suppliers.



MAX5389 Evaluation Kit

Quick Start

Required Equipment

- MAX5389 EV kit
- 5V, 100mA power supply
- Two multimeters

Procedure

The MAX5389 EV kit is fully assembled and tested. Follow the steps below to verify board operation:

- 1) Verify that shunts are configured in the EV kit default state for proper startup operation (see Table 1).
- 2) Apply a 5V power source across the VIN and GND PCB pads.
- 3) Connect the multimeters to measure voltage across the WA and LA PCB pads and WB and LB PCB pads

Table 1. Jumper Configuration (JU1–JU11)

JUMPER	SHUNT POSITION	EV KIT FUNCTION
JU1	1-2	VDD = 3.3V
	1-3*	VDD = 2.6V
	1-4	VDD = Voltage applied at the VIN PCB pad
	Not installed	VDD not powered or VDD signal applied at header J1-1
JU2	Installed	$\overline{\text{CSA}}$ input pushbutton controlled
	Not installed*	$\overline{\text{CSA}}$ input logic-low or signal applied at header J1-3
JU3	Installed*	UDA input pushbutton controlled
	Not installed	UDA input connects to the VIN supply or power applied at header J1-5
JU4	Installed*	$\overline{\text{INCA}}$ input pushbutton controlled
	Not installed	$\overline{\text{INCA}}$ input connects to the VIN supply or power applied at header J1-7
JU5	Installed	$\overline{\text{CSB}}$ input pushbutton controlled
	Not installed*	$\overline{\text{CSB}}$ input logic-low or signal applied at header J1-9
JU6	Installed*	UDB input pushbutton controlled
	Not installed	UDB input connects to the VIN supply or power applied at header J1-11
JU7	Installed*	$\overline{\text{INCB}}$ input pushbutton controlled
	Not installed	$\overline{\text{INCB}}$ input connects to the VIN supply or power applied at header J1-13
JU8	Installed*	HA connected to the VDD voltage source
	Not installed	HA disconnected from the VDD voltage source
JU9	Installed*	LA connected to GND
	Not installed	LA disconnected from GND
JU10	Installed*	HB connected to the VDD voltage source
	Not installed	HB disconnected from the VDD voltage source
JU11	Installed*	LB connected to GND
	Not installed	LB disconnected from GND

*Default position.

MAX5389 Evaluation Kit

Evaluates: MAX5389

Detailed Description of Hardware

The MAX5389 EV kit is an assembled and tested PCB that features the MAX5389M 50kΩ dual digital potentiometer. Each potentiometer has an end-to-end resistance of 50kΩ. Each 256-tap wiper position can be controlled independently using pushbutton switches. The EV kit uses a MAX5389M IC in a 14-pin TSSOP package on a proven two-layer PCB design.

The EV kit supports both mechanical and digital inputs to control the potentiometer wiper positions using jumpers JU2–JU7. Install shunts across jumpers JU2–JU7 to control the MAX5389 logic inputs using pushbutton switches SW1–SW6, respectively. See the *Potentiometer A Control* and *Potentiometer B Control* sections for additional information.

The EV kit provides connector J1 to interface the MAX5389 CSA, CSB, INCA, INCB, UDA, and UDB signals directly to a user-supplied signal. Connector J1 also provides a connection to the MAX5389 VDD input.

EV Kit Power Source

The EV kit operates from a 2.8V to 5.5V power supply applied at the VIN and GND PCB pads. VIN powers the MAX5389M (U1), two MAX8511 LDO regulators (U2, U3), and the MAX6818 debouncer switch (U4). Regulators U2 and U3 are used to set the MAX5389 VDD input to 3.3V or 2.6V, respectively.

Jumper JU1 selects the voltage applied at the MAX5389 VDD input. See Table 2 for proper jumper configuration for setting the MAX5389 VDD input.

Note that the EV kit VIN input operates down to 2.6V. However, a minimum 2.7V, 2.8V, and 3.5V is required when operating debouncer U4, LDO U3, and LDO U2, respectively.

Table 2. MAX5389 VDD Input (JU1)

SHUNT POSITION	MAX5389 VDD Voltage
1-2	3.3V (LDO U2)
1-3	2.6V (LDO U3)
1-4	Voltage applied at the VIN and GND PCB pads
Not installed	VDD not powered or power applied at header J1-1

Digital Interface

Wiper WA positioning can be controlled through momentary pushbutton switches SW1 (POTA_CSA), SW2 (POTA_UDA), and SW3 (POTA_INCA) by installing shunts across jumpers JU2, JU3, and JU4, respectively. Wiper WB positioning can be controlled through momentary pushbutton switches SW4 (POTB_CSB), SW5 (POTB_UDB), and SW6 (POTB_INCB) by installing shunts across jumpers JU5, JU6, and JU7 respectively. The debouncer (U4) eliminates the “contact bounce” that SW1–SW6 can exhibit and is not required if using a digital interface.

The EV kit also provides connector J1 to interface the MAX5389 CSA, CSB, INCA, INCB, UDA, and UDB inputs directly to user-supplied digital signals. See Table 3 for header J1 pin assignments. Refer to the *Up/Down Interface* section in the MAX5389 IC data sheet for a more detailed description.

Potentiometer A Control

Jumpers JU2, JU3, and JU4 configure the EV kit operation for pushbutton control of the MAX5389 CSA, UDA, and INCA digital inputs, respectively. Install shunts across jumpers JU2, JU3, and JU4 for wiper WA positioning using pushbutton switches SW1, SW2, and SW3. SW1 sets chip-select input CSA low. SW2 configures the wiper for incrementing or decrementing operation (UDA). SW3 controls the wiper position (INCA). The MAX5389 increments or decrements wiper WA position on a high-to-low transition at INCA.

Remove the shunts at JU2, JU3, and JU4 to position wiper WA using digital signals at header J1 (pins J1-3, J1-5, and J1-7). See Table 1 for proper JU2, JU3, and JU4 jumper configurations.

Table 3. Header J1 Pin Assignments

PIN	SIGNAL
J1-1	VDD
J1-2, J1-4, J1-6, J1-8, J1-10, J1-12, J1-14, J1-16	GND
J1-3	CSA
J1-5	UDA
J1-7	INCA
J1-9	CSB
J1-11	UDB
J1-13	INCB

MAX5389 Evaluation Kit

To increment wiper WA position:

- 1) Press SW1 and hold ($\overline{\text{CSA}} = \text{low}$), or remove the shunt at jumper JU2.
- 2) Press, then release SW3 ($\overline{\text{INCA}}$ high-to-low transition).

To decrement wiper WA position:

- 1) Press SW1 and hold ($\overline{\text{CSA}} = \text{low}$), or remove the shunt at jumper JU2.
- 2) Press SW2 and hold ($\text{UDA} = \text{low}$).
- 3) Press, then release SW3 ($\overline{\text{INCA}}$ high-to-low transition).

Potentiometer B Control

Jumpers JU5, JU6, and JU7 configure the EV kit operation for pushbutton control of the MAX5389 $\overline{\text{CSB}}$, UDB, and $\overline{\text{INCB}}$ digital inputs, respectively. Install shunts across jumpers JU5, JU6, and JU7 for wiper WB positioning using pushbutton switches SW4, SW5, and SW6. SW4 sets chip-select input $\overline{\text{CSB}}$ low. SW5 configures the wiper for incrementing or decrementing operation (UDB). SW6 controls the wiper position. The MAX5389 increments or decrements the wiper WB position on a high-to-low transition at $\overline{\text{INCB}}$.

Remove the shunts at JU5, JU6, and JU7 to position WB using digital signals at header J1 (pins J1-9, J1-11, and J1-13). See Table 1 for proper JU5, JU6, and JU7 jumper configurations.

To increment wiper WB position:

- 1) Press SW4 and hold ($\overline{\text{CSB}} = \text{low}$), or remove the shunt at jumper JU5.

- 2) Press, then release SW6 ($\overline{\text{INCB}}$ high-to-low transition).

To decrement wiper WB position:

- 1) Press SW4 and hold ($\overline{\text{CSB}} = \text{low}$), or remove the shunt at jumper JU5.
- 2) Press SW5 and hold ($\text{UDA} = \text{low}$).
- 3) Press, then release SW6 ($\overline{\text{INCB}}$ high-to-low transition).

Potentiometer, Voltage-Divider or Variable Resistor, with Ground Reference

The EV kit provides an option to configure the MAX5389 as a potentiometer or a voltage-divider open-ended or with ground reference, respectively. Use jumpers JU8 and JU9 for potentiometer A and jumpers JU10 and JU11 for potentiometer B configuration. Tables 4 and 5 list the jumper options for configuring potentiometers A and B.

The MAX5389 can also be configured as a variable resistor by shorting the H_ and W_ pads using a wire. When operating as a variable resistor, any power source connected to the H_, W_, or L_ pad must be voltage and current limited to the maximum conditions stated in the MAX5389 IC data sheet.

Note that to test the device in resistor mode, the ohmmeter must be GND referenced to the MAX5389. This can be accomplished by connecting the L_ pad to GND or the H_ pad to VDD. Resistance is then measured between the W_ and L_ or W_ and H_ PCB pads.

Table 4. JU8 and JU9 Jumper Functions (Potentiometer A)

SHUNT POSITION		HA PAD	LA PAD	MAX5389 FUNCTION
JU8	JU9			
Not installed*	Not installed	Not connected	Not connected	Potentiometer open-ended
	Installed*		Connected to GND	Potentiometer with GND reference
Installed	Not installed	Connected to VDD	Not connected	Voltage-divider open-ended
	Installed		Connected to GND	Voltage-divider with GND reference

*Default position.

Table 5. JU10 and JU11 Jumper Functions (Potentiometer B)

SHUNT POSITION		HB PAD	LB PAD	MAX5389 FUNCTION
JU10	JU11			
Not installed*	Not installed	Not connected	Not connected	Potentiometer open-ended
	Installed*		Connected to GND	Potentiometer with GND reference
Installed	Not installed	Connected to VDD	Not connected	Voltage-divider open-ended
	Installed		Connected to GND	Voltage-divider with GND reference

*Default position.

MAX5389 Evaluation Kit

Evaluates: **MAX5389**

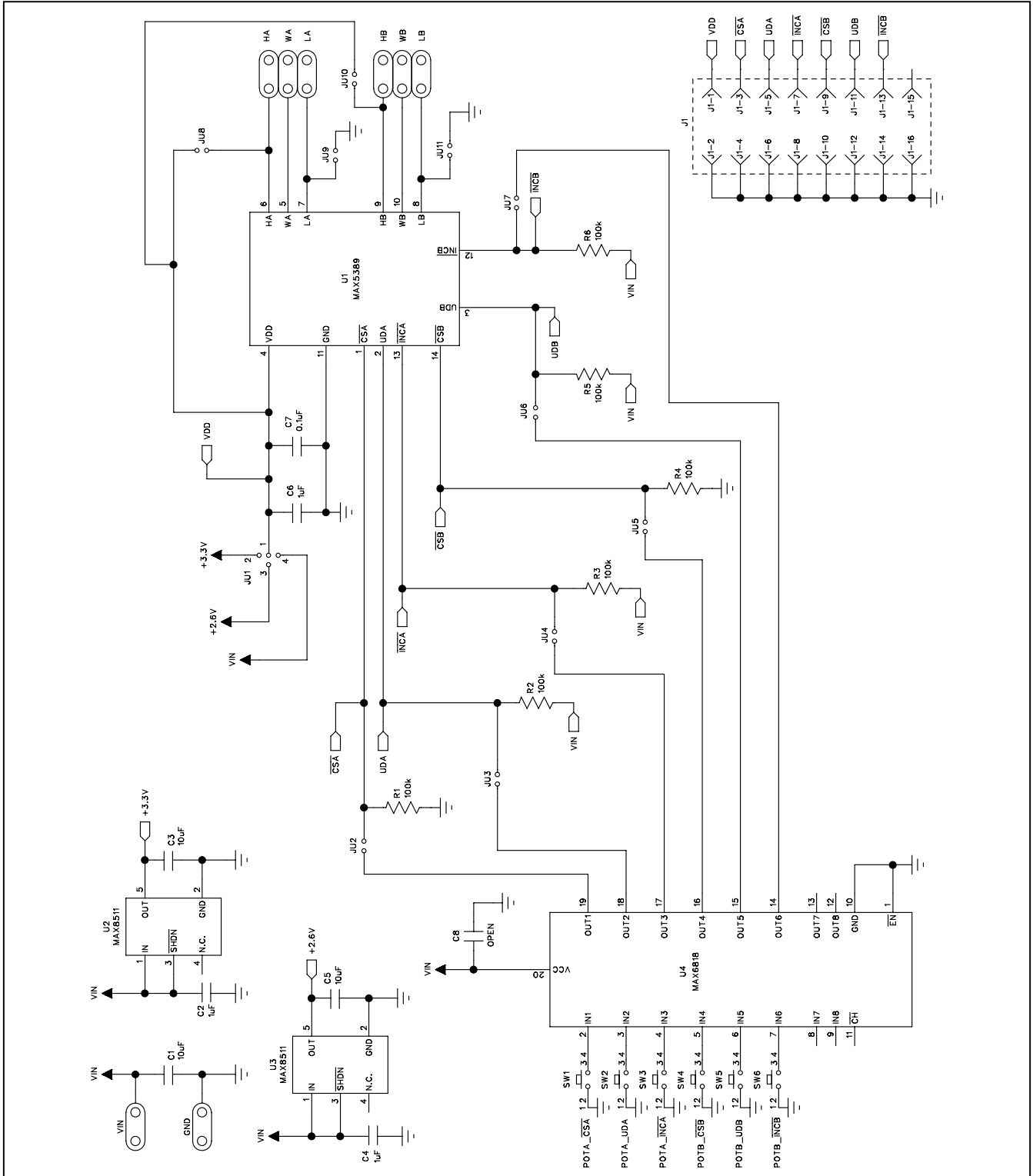

Figure 1. MAX5389 EV Kit Schematic

MAX5389 Evaluation Kit

Evaluates: MAX5389

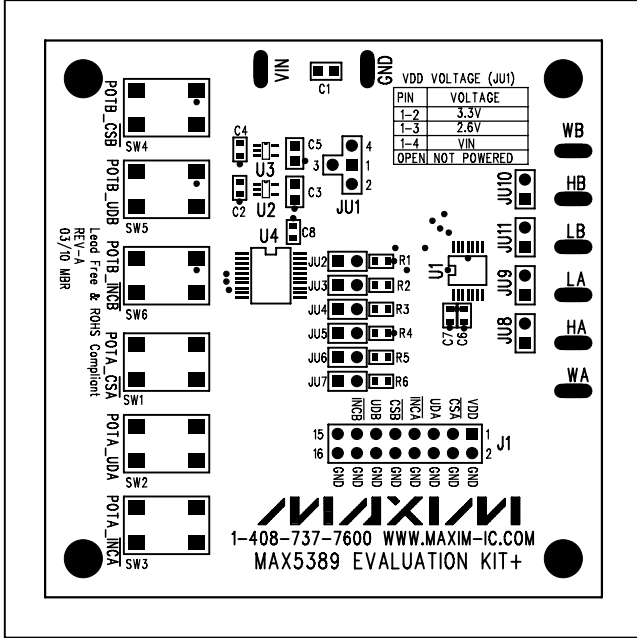

Figure 2. MAX5389 EV Kit Component Placement Guide—Component Side

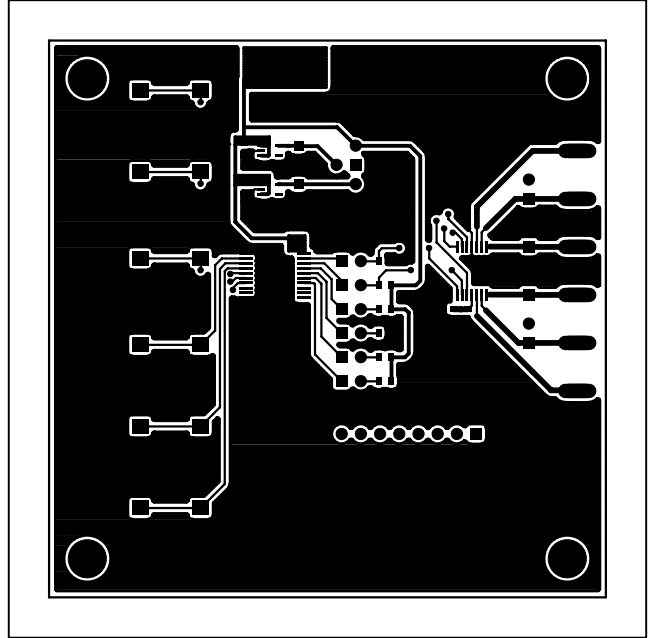

Figure 3. MAX5389 EV Kit PCB Layout—Component Side

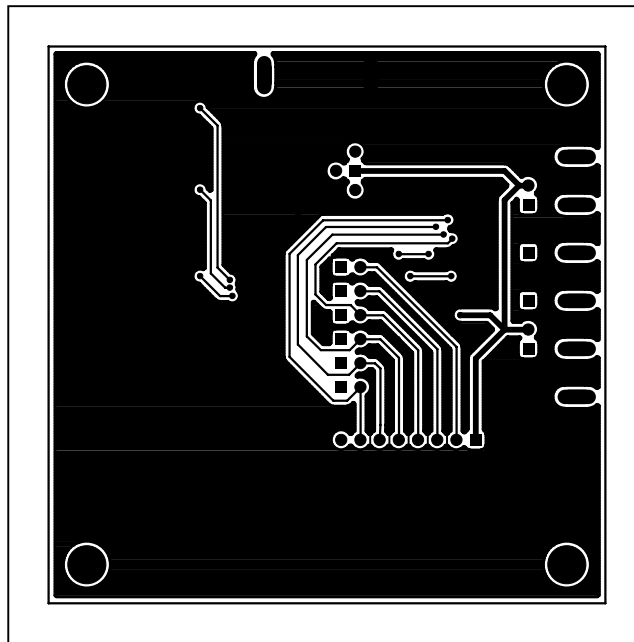

Figure 4. MAX5389 EV Kit PCB Layout—Solder Side

MAX5389 Evaluation Kit

Revision History

REVISION NUMBER	REVISION DATE	DESCRIPTION	PAGES CHANGED
0	4/10	Initial release	—

Evaluates: MAX5389

Maxim cannot assume responsibility for use of any circuitry other than circuitry entirely embodied in a Maxim product. No circuit patent licenses are implied. Maxim reserves the right to change the circuitry and specifications without notice at any time.

Maxim Integrated Products, 120 San Gabriel Drive, Sunnyvale, CA 94086 408-737-7600 _____ 7

X-ON Electronics

Largest Supplier of Electrical and Electronic Components

Click to view similar products for [Digital Potentiometer Development Tools](#) category:

Click to view products by [Maxim](#) manufacturer:

Other Similar products are found below :

[EVAL-AD5162SDZ](#) [EVAL-AD5232SDZ](#) [EVAL-AD5246DBZ](#) [EVAL-AD5258DBZ](#) [EVAL-AD5204SDZ](#) [EVAL-AD5259DBZ](#) [PIM523](#)
[MCP43XXEV](#) [MCP401XEV](#) [356](#) [2273](#) [4219](#) [4271](#) [4272](#) [4286](#) [4493](#) [4570](#) [EVAL-AD5111SDZ](#) [EVAL-AD5116EBZ](#) [EVAL-](#)
[AD5142ADBZ](#) [EVAL-AD5161DBZ](#) [EVAL-AD5242DBZ](#) [EVAL-AD5243SDZ](#) [EVAL-AD5270SDZ](#) [MAX5487PMB1#](#) [MCP402XEV](#)
[MCP42XXEV](#) [MCP46XXEV](#) [MIKROE-3402](#) [MIKROE-3691](#) [MIKROE-4110](#) [MIKROE-198](#) [MIKROE-2332](#) [MIKROE-2702](#) [MIKROE-](#)
[2863](#) [MIKROE-2873](#) [MIKROE-316](#) [MIKROE-3301](#) [MIKROE-923](#) [PRT-13144](#) [101020036](#) [EVAL-AD5110SDZ](#) [EVAL-AD5141DBZ](#)
[EVAL-AD5142DBZ](#) [EVAL-AD5143DBZ](#) [EVAL-AD5144DBZ](#) [EVAL-AD8403SDZ](#) [EVAL-AD5160DBZ](#) [EVAL-AD5245DBZ](#) [EVAL-](#)
[AD5254SDZ](#)