

MAX6078 Evaluation Kit

Evaluates: MAX6078A

General Description

The MAX6078 evaluation kit (EV kit) is a fully assembled and tested circuit board for evaluating the MAX6078 family of low-power, low-noise, low-drift voltage references. The EV kit features footprints for both 6-bump WLP and 8-pin TDFN-EP surface-mount packages to evaluate any part in the reference family. These references operate from a single 2.3V to 5.5V supply and provide output options of 1.25V, 2.048V, 2.5V, 3.0V, 3.3V, 4.096V, and 5.0V.

The EV kit comes with a 6-bump WLP, 2.5V output (MAX6078AMWT25+) installed on the U1 footprint, while the TDFN-EP U2 (MAX6078AMTA25+) is a future product. This EV kit can also be used to evaluate any devices in the MAX6078 family.

Features

- 2.3V to 5.5V Input Supply Range
- Output Options: 1.25V, 2.048V, 2.5V, 3.0V, 3.3V, 4.096V, and 5.0V.
- Proven PCB Layout
- Fully Assembled and Tested
- Evaluate any Devices of the MAX6078 Family

Ordering Information appears at end of data sheet.

MAX6078 EV Kit Photo

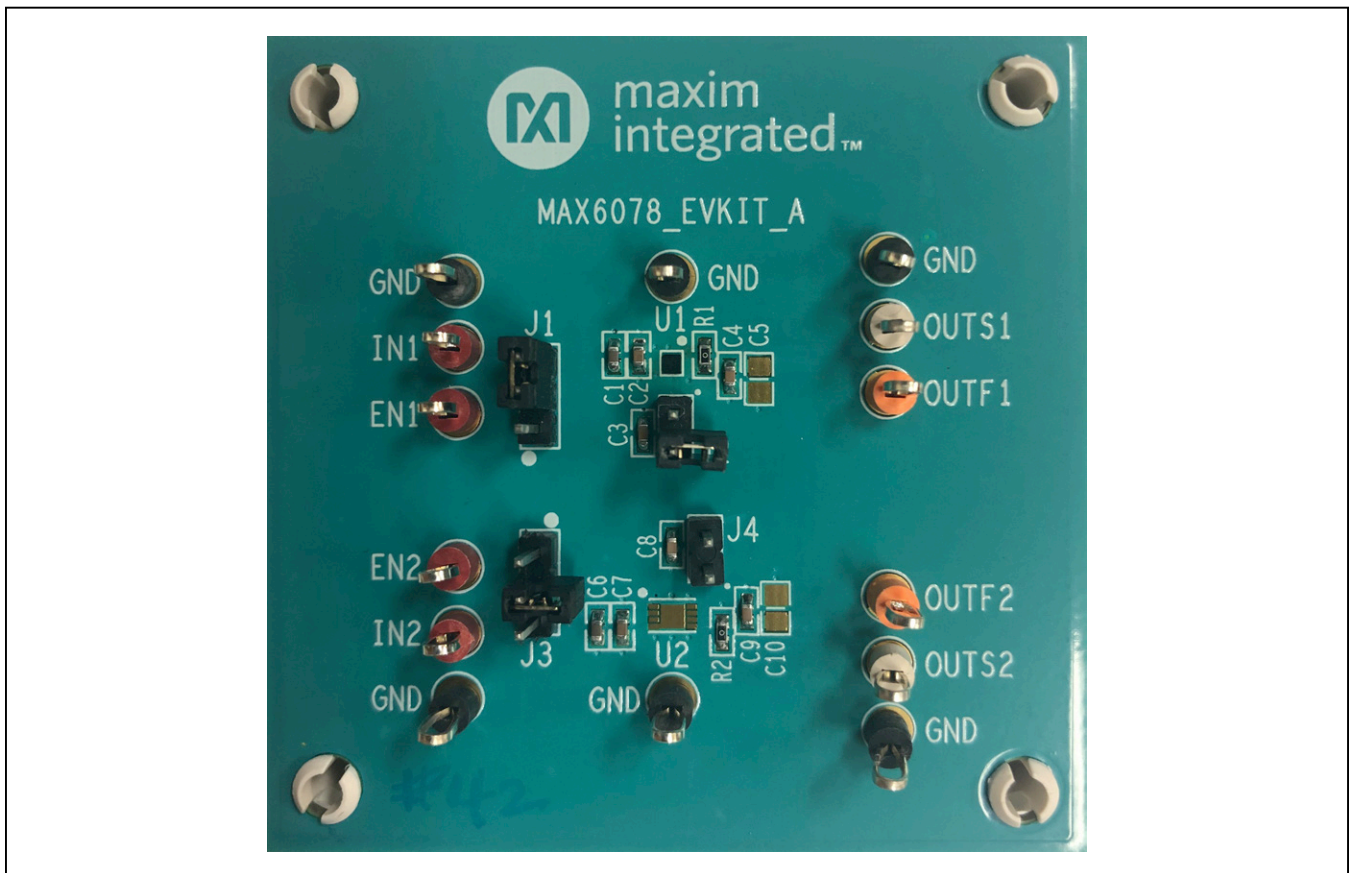

Quick Start

Required Equipment

- MAX6078 EV kit
- +5V DC Power supply
- Voltmeter

Procedure

The EV kit is fully assembled and tested. Follow the steps below to verify board operation:

- 1) Verify that jumpers J1, J2, J3, and J4 are in their default position, as shown in [Table 1](#) and [Table 2](#).
- 2) **To evaluate U1:** set the DC power supply to +5V. Connect the positive terminal to the IN1 test point and the negative terminal to GND test point.
- 3) Connect the voltmeter between OUTF1 and GND test point.
- 4) Turn on the DC power supply.
- 5) Verify that the voltmeter displays $V_{OUTF1} = 2.5V$.
- 6) **To evaluate U2:** repeat step 2 to step 5 above for the U2 section. U2 (MAX6078AMTA25+) is a future product.

Table 1. Jumper Description for U1

JUMPER	SHUNT POSITION	DESCRIPTION
J1	2-1	Connect EN1 to GND to Place U1 in Shutdown Mode (U1)
	2-3*	Connect EN1 to IN1 for Normal Operation (U1)
J2	Installed	Connect C3 to NR Input (U1) for Output Noise Reduction
	Not installed*	C3 not connected to NR Input (U1)

*Default position.

General Description of Hardware

The MAX6078 EV kit demonstrates the MAX6078 family of very low-power, low-noise, low-drift voltage references in both available footprints: a 6-bump WLP and an 8-pin TDFN-EP package. The EV kit requires an input supply voltage range from 2.3V to +5.5V at the IN_ pin for normal operation.

EN Input

Drive the EN_ pin high or connect to IN_ to enable the MAX6078. Drive the EN_ pin low or connect it to ground to disable the device. J1 (U1) and J3 (U2) are used for enabling or disabling the devices.

Noise Reduction (NR) Input

The MAX6078 EV kit has jumpers available for evaluating the MAX6078's noise reduction feature. Install the jumper J2 (U1) and J4 (U2) to connect an external capacitor to the noise reduction input pins (NR) to use this feature.

Table 2. Jumper Description for U2

JUMPER	SHUNT POSITION	DESCRIPTION
J3	2-1	Connect EN2 to GND to Place U2 in Shutdown Mode (U2)
	2-3*	Connect EN2 to IN2 for Normal Operation (U2)
J4	Installed	Connect C8 to NR Input (U2) for Output Noise Reduction
	Not installed*	C8 not connected to NR Input (U2)

*Default position.

Ordering Information

PART	TYPE
MAX6078EVKIT#	EV KIT

#Denotes RoHS compliant.

MAX6078 EV Kit Bill of Materials

ITEM	REF_DES	DNI/DNP	QTY	MFG PART #	MANUFACTURER	VALUE	DESCRIPTION
1	C1, C6	—	2	GRM188R71E105KA12; CGA3E1X7R1E105K; TMK107B7105KA; 06033C105KAT2A; GCM188R71E105KA64	MURATA;TDK; TAIYO YUDEN; AVX;MURATA	1UF	CAPACITOR; SMT (0603); CERAMIC CHIP; 1µF; 25V; TOL = 10%; TG = -55°C TO +125°C; TC = X7R
2	C2, C4, C7, C9	—	4	C1608X7R1E104K080AA	TDK	0.1UF	CAPACITOR; SMT (0603); CERAMIC CHIP; 0.1µF; 25V; TOL = 10%; MODEL = C SERIES; TG = -55°C TO +125°C; TC = X7R
3	C3, C8	—	2	GRM188R71E103KA01	MURATA	0.01UF	CAPACITOR; SMT (0603); CERAMIC CHIP; 0.01µF; 25V; TOL = 10%; TG = -55°C TO +125°C
4	EN1, EN2, IN1, IN2	—	4	5010	KEYSTONE	N/A	TEST POINT; PIN DIA = 0.125IN; TOTAL LENGTH = 0.445IN; BOARD HOLE = 0.063IN; RED; PHOSPHOR BRONZE WIRE SIL;
5	GND1-GND6	—	6	5011	KEYSTONE	N/A	TEST POINT; PIN DIA = 0.125IN; TOTAL LENGTH = 0.445IN; BOARD HOLE = 0.063IN; BLACK; PHOSPHOR BRONZE WIRE SILVER PLATE FINISH;
6	J1, J3	—	2	PEC03SAAN	SULLINS	PEC03SAAN	CONNECTOR; MALE; THROUGH HOLE; BREAKAWAY; STRAIGHT; 3PINS
7	J2, J4	—	2	PEC02SAAN	SULLINS	PEC02SAAN	CONNECTOR; MALE; THROUGH HOLE; BREAKAWAY; STRAIGHT; 2PINS
8	MH1-MH4	—	4	9032	KEYSTONE	9032	MACHINE FABRICATED; ROUND-THRU HOLE SPACER; NO THREAD; M3.5; 5/8IN; NYLON
9	OUTF1, OUTF2	—	2	5013	KEYSTONE	N/A	TEST POINT; PIN DIA = 0.125IN; TOTAL LENGTH = 0.445IN; BOARD HOLE = 0.063IN; ORANGE; PHOSPHOR BRONZE WIRE SILVER PLATE FINISH;
10	OUTS1, OUTS2	—	2	5012	KEYSTONE	N/A	TEST POINT; PIN DIA = 0.125IN; TOTAL LENGTH = 0.445IN; BOARD HOLE = 0.063IN; WHITE; PHOSPHOR BRONZE WIRE SILVER PLATE FINISH;
11	R1, R2	—	2	CRCW06030000ZS; MCR03EZPJ000; ERJ-3GEY0R00	VISHAY DALE;ROHM; PANASONIC	0	RESISTOR; 0603; 0Ω; 0%; JUMPER; 0.10W; THICK FILM
12	SU1, SU2	—	2	S1100-B;SX1100-B; STC02SYAN	KYCON;KYCON; SULLINS ELECTRONICS CORP.	SX1100-B	TEST POINT; JUMPER; STR; TOTAL LENGTH = 0.24IN; BLACK; INSULATION = PBT;PHOSPHOR BRONZE CONTACT = GOLD PLATED
13	U1	—	1	MAX6078AMWT25+	MAXIM	MAX6078AMWT25+	EVKIT PART-IC; MAX6078AMWT25+; PACKAGE OUTLINE DRAWING: 21-100365; PACKAGE LAND PATTERN: USE APPLICATION NOTE 1981
14	U2	*	*	MAX6078AMTA25+	MAXIM	MAX6078AMTA25+	EVKIT PART-IC; MAX6078AMTA25+; PACKAGE OUTLINE DRAWING: 21-0174; PACKAGE LAND PATTERN: 90-0091
15	PCB	—	1	MAX6078	MAXIM	PCB	PCB:MAX6078
16	C5, C10	DNP	0	GRM21BR71C475KA73; 0805YC475KAT2A	MURATA;AVX	4.7UF	CAPACITOR; SMT (0805); CERAMIC CHIP; 4.7µF; 16V; TOL = 10%; MODEL = GRM SERIES; TG = -55°C TO +125°C; TC = X7R
TOTAL			37				

*U2 is a future product.

MAX6078 EV Kit Schematic

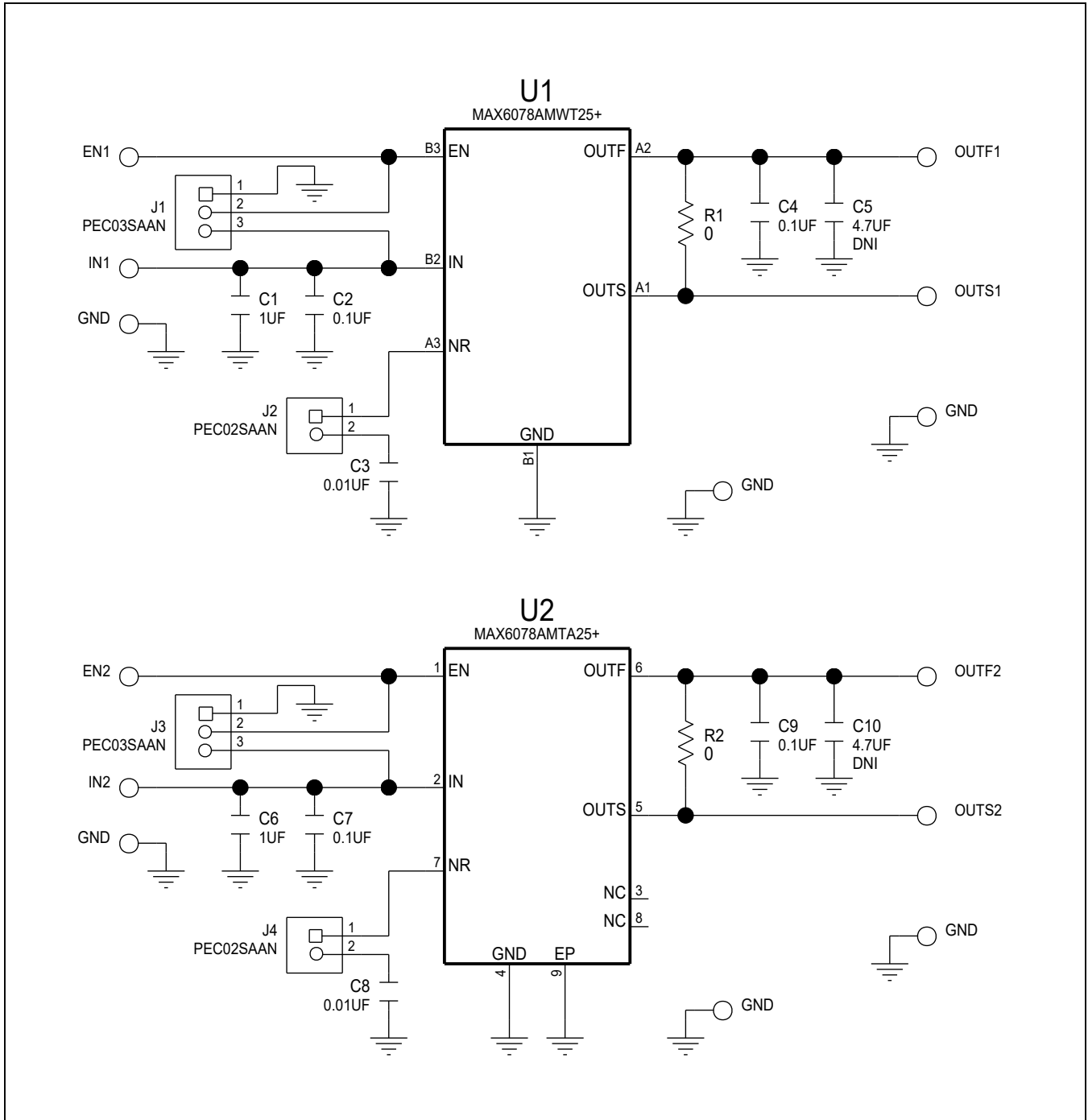

MAX6078 EV Kit PCB Layout Diagrams

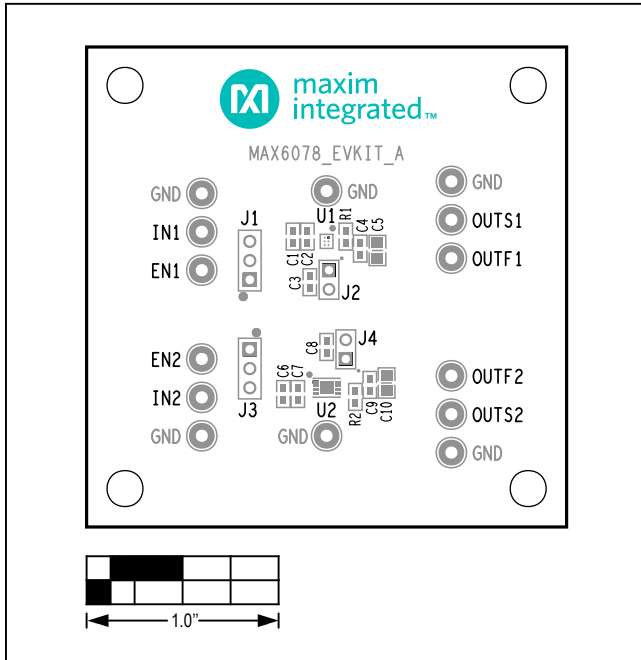

MAX6078 EV Kit Component Placement Guide—Top Silkscreen

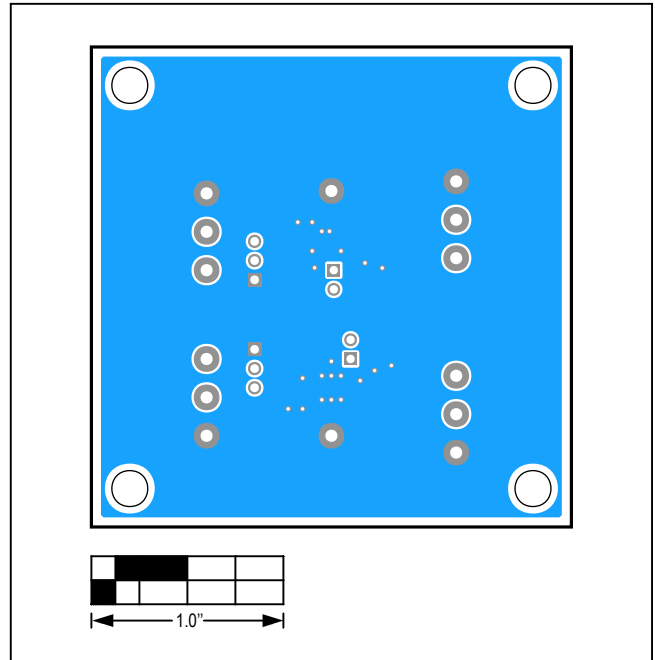

MAX6078 EV Kit PCB Layout—Bottom View

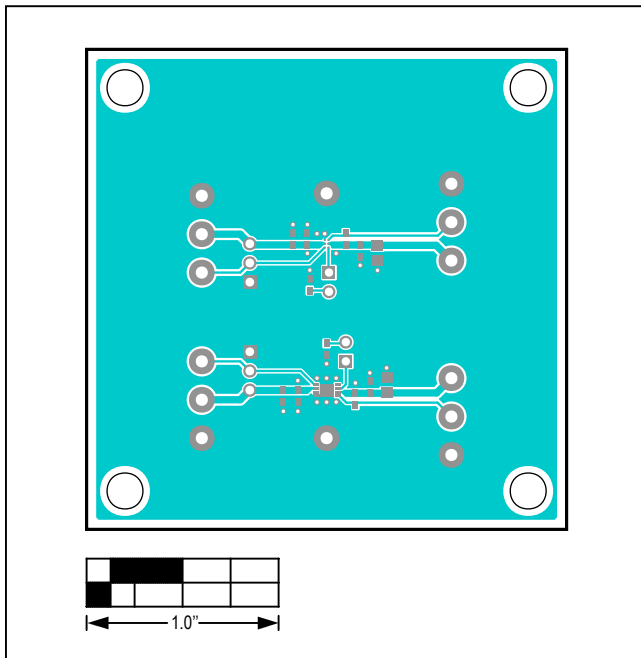

MAX6078 EV Kit PCB Layout—Top View

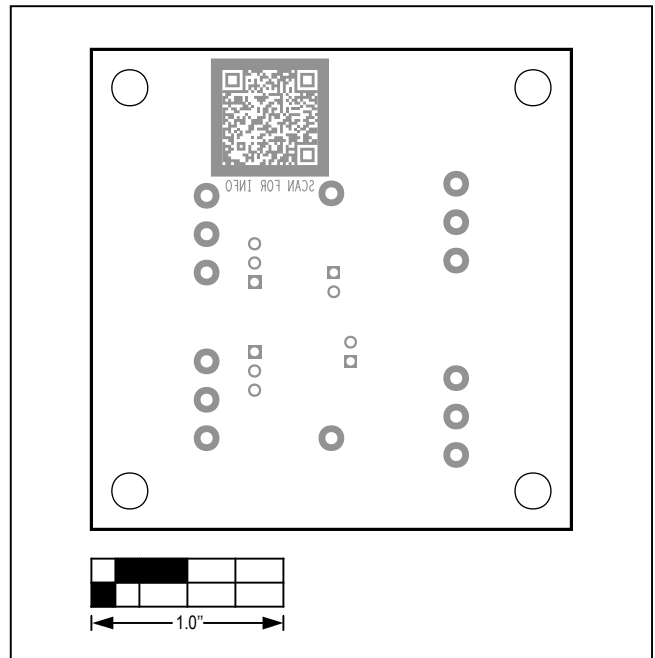

MAX6078 EV Kit Component Placement Guide—Bottom Silkscreen

Revision History

REVISION NUMBER	REVISION DATE	DESCRIPTION	PAGES CHANGED
0	6/19	Initial release	—

For pricing, delivery, and ordering information, please visit Maxim Integrated's online storefront at <https://www.maximintegrated.com/en/storefront/storefront.html>.

Maxim Integrated cannot assume responsibility for use of any circuitry other than circuitry entirely embodied in a Maxim Integrated product. No circuit patent licenses are implied. Maxim Integrated reserves the right to change the circuitry and specifications without notice at any time.

X-ON Electronics

Largest Supplier of Electrical and Electronic Components

Click to view similar products for [Power Management IC Development Tools](#) category:

Click to view products by [Maxim](#) manufacturer:

Other Similar products are found below :

[EVB-EP5348UI](#) [MIC23451-AAAYFL EV](#) [MIC5281YMME EV](#) [124352-HMC860LP3E](#) [DA9063-EVAL](#) [ADP122-3.3-EVALZ](#) [ADP130-0.8-EVALZ](#) [ADP130-1.8-EVALZ](#) [ADP1740-1.5-EVALZ](#) [ADP1870-0.3-EVALZ](#) [ADP1874-0.3-EVALZ](#) [ADP199CB-EVALZ](#) [ADP2102-1.25-EVALZ](#) [ADP2102-1.875EVALZ](#) [ADP2102-1.8-EVALZ](#) [ADP2102-2-EVALZ](#) [ADP2102-3-EVALZ](#) [ADP2102-4-EVALZ](#) [AS3606-DB](#) [BQ25010EVM](#) [BQ3055EVM](#) [ISLUSBI2CKIT1Z](#) [LP38512TS-1.8EV](#) [EVAL-ADM1186-1MBZ](#) [EVAL-ADM1186-2MBZ](#) [ADP122UJZ-REDYKIT](#) [ADP166Z-REDYKIT](#) [ADP170-1.8-EVALZ](#) [ADP171-EVALZ](#) [ADP1853-EVALZ](#) [ADP1873-0.3-EVALZ](#) [ADP198CP-EVALZ](#) [ADP2102-1.0-EVALZ](#) [ADP2102-1-EVALZ](#) [ADP2107-1.8-EVALZ](#) [ADP5020CP-EVALZ](#) [CC-ACC-DBMX-51](#) [ATPL230A-EK](#) [MIC23250-S4YMT EV](#) [MIC26603YJL EV](#) [MIC33050-SYHL EV](#) [TPS60100EVM-131](#) [TPS65010EVM-230](#) [TPS71933-28EVM-213](#) [TPS72728YFFEVM-407](#) [TPS79318YEQEVM](#) [UCC28810EVM-002](#) [XILINXPWR-083](#) [LMR22007YMINI-EVM](#) [LP38501ATJ-EV](#)