

Evaluates: MAX6226

MAX6226 Evaluation Kit

General Description

The MAX6226 evaluation kit (EV kit) provides a proven design to evaluate the MAX6226 low-noise precision ceramic voltage reference. The output voltage is set at 2.5V.

The EV kit comes installed with a MAX6226ALA25+ in 8-pin ceramic Leadless Chip Carrier (LCC) package. To evaluate other output voltage options, replace the U1 IC preinstalled with the desired part.

Features

- Configurable for Precision Current Source
- Proven PCB Layout
- Fully Assembled and Tested

[Ordering Information](#) appears at end of data sheet.

Quick Start

Required Equipment

- MAX6226 EV kit
- +5V DC power supply
- Voltmeter

Procedure

The EV kit is fully assembled and tested. Follow the steps below to verify board operation:

- 1) Set the DC power supply to +5V. Connect the positive terminal to the IN test point and the negative terminal to GND test point.
- 2) Connect the voltmeter between OUTF and GND test point.
- 3) Turn on the DC power supply.
- 4) Verify that the voltmeter displays 2.5V.

MAX6226 EV Kit Photo

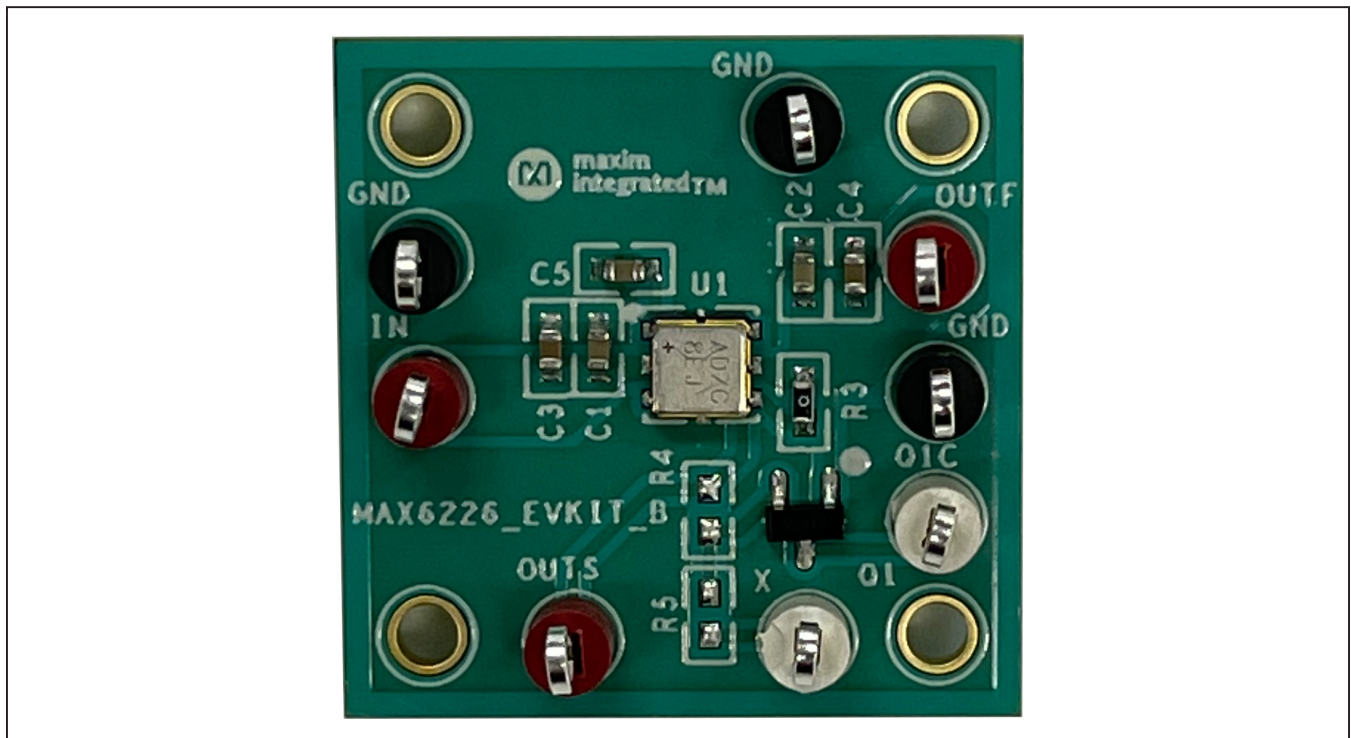

General Description of Hardware

The MAX6226 EV kit demonstrates the MAX6226, a very low noise and low-drift voltage reference in a small 8-pin LCC package. The EV kit requires a +2.7V to +12.6V input supply voltage at the IN pin for normal operation.

Precision Current Source

To use the EV kit as a precision current source, remove the resistor at R3, install a 0Ω resistor at location R4, and connect the X test point to GND. Install an appropriate resistor at location R5 to determine the current by using the following equation.

$$I_{SOURCE} = \frac{V_{OUT(NOMINAL)}}{R5}$$

Ordering Information

PART	TYPE
MAX6226EVKIT#	EV Kit

#Denotes RoHS compliant.

MAX6226 EV Kit Bill of Materials

ITEM	REF_DES	QTY	MFG PART #	MANUFACTURER	VALUE	DESCRIPTION
1	C1, C2, C5	3	C0603C104K5RAC;C1608X7R1H104K; ECJ-1VB1H104K;GRM188R71H104KA93; CGJ3E2X7R1H104K080AA; C1608X7R1H104K080AA; CL10B104KB8NHN;CL10B104KB8NFN	KEMET;TDK;PANASONIC; MURATA; TDK; TDK; SAMSUNG ELECTRO-MECHANICS; SAMSUNG ELECTRONICS	0.1UF	CAPACITOR; SMT (0603); CERAMIC CHIP; 0.1UF; 50V; TOL=10%; TG=-55 DEGC TO +125 DEGC; TC=X7R;
2	C3, C4	2	C0603C105K4RAC;GRM188R71C105KA12; C1608X7R1C105K080AC;EMK107B7105KA; GCM188R71C105KA64; CGA3E1X7R1C105K080AC;0603YC105KAT2A	KEMET;MURATA;TDK; TAIYO YUDEN; MURATA;TDK;AVX	1UF	CAPACITOR; SMT (0603); CERAMIC CHIP; 1UF; 16V; TOL=10%; MODEL=; TG=-55 DEGC TO +125 DEGC; TC=X7R
3	GND, TP1, TP2	3	5006	KEYSTONE	N/A	TEST POINT; PIN DIA=0.125IN; TOTAL LENGTH=0.35IN; BOARD HOLE=0.063IN; BLACK; PHOSPHOR BRONZE WIRE SILVER PLATE FINISH;
4	IN, OUTF, OUTS	3	5005	KEYSTONE	N/A	TEST POINT; PIN DIA=0.125IN; TOTAL LENGTH=0.35IN; BOARD HOLE=0.063IN; RED; PHOSPHOR BRONZE WIRE SILVER PLATE FINISH;
5	Q1	1	MMBT3904LT3G	ON SEMICONDUCTOR	MMBT3904	TRANSISTOR, NPN, SOT-23, PD=0.225W, IC=0.2A, VCEO=40V
6	Q1C, X	2	5007	KEYSTONE	N/A	TEST POINT; PIN DIA=0.125IN; TOTAL LENGTH=0.35IN; BOARD HOLE=0.063IN; WHITE; PHOSPHOR BRONZE WIRE SILVER PLATE FINISH;
7	R3	1	CRCW06030000Z5;MCR03EZPJ000; ERJ-3GEY0R00	VISHAY DALE;ROHM; PANASONIC	0	RESISTOR; 0603; 0 OHM; 0%; JUMPER; 0.10W; THICK FILM
8	U1	1	MAX6226ALA25+	MAXIM	MAX6226ALA25+	IC; VREF; ULTRA-HIGH-PRECISION; ULTRA-LOW-NOISE; SERIES VOLTAGE REFERENCE VOLTAGE REFERENCE; LCC7
9	PCB	1	MAX6226	MAXIM	PCB	PCB:MAX6226
10	R4, R5	DNP	N/A	N/A	OPEN	PACKAGE OUTLINE 0603 RESISTOR
TOTAL		17				

MAX6226 EV Kit Schematic (*)

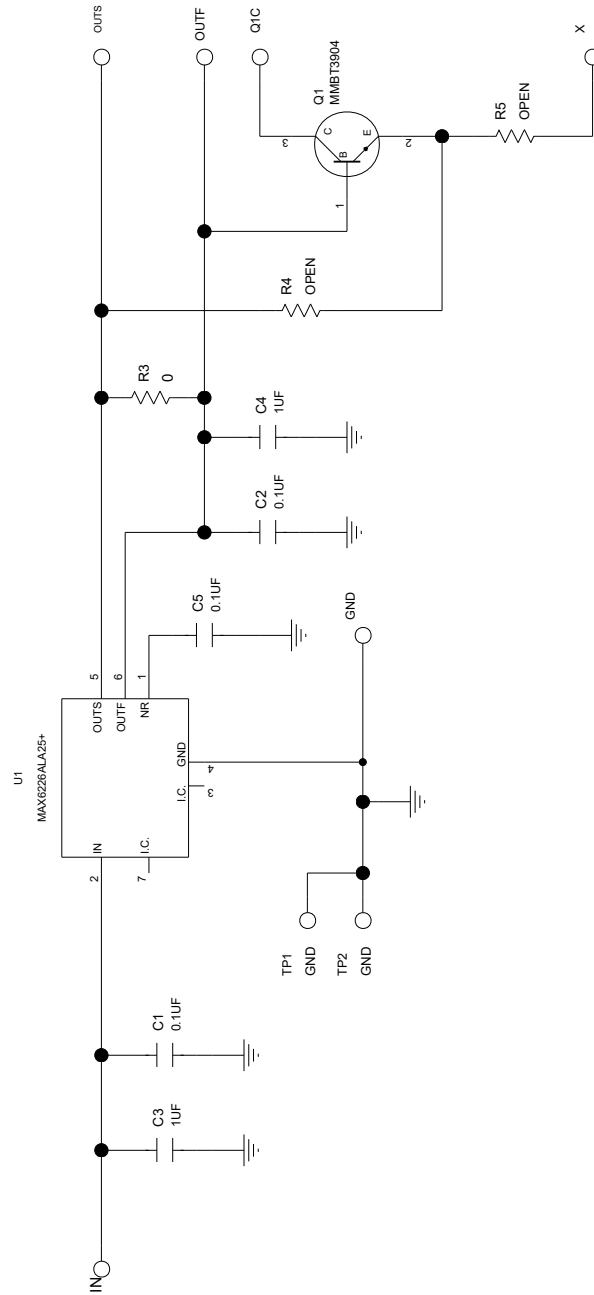

(*) Pin 8 (I.C.) should not be connected to anything for best performance, so it is not shown in the schematic. Pin 8 must be clear of any mechanical and electrical contact. Neither copper nor solder/paste mask must be placed underneath its land pattern. The absence of mechanical contact eliminates the possibility of paddle induced stress to the die. The absence of electrical contact eliminates the possibility of any ground current redistribution.

MAX6226 EV Kit PCB Layouts

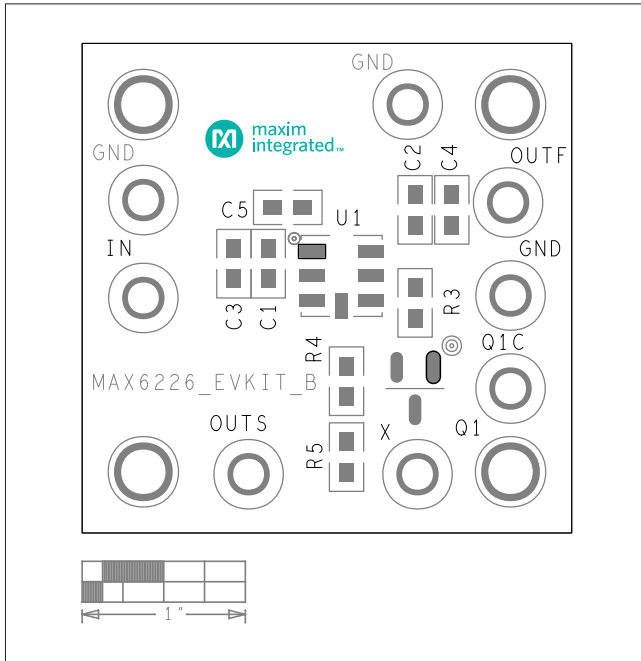

MAX6226 EV Kit Component Placement Guide—Top Silkscreen

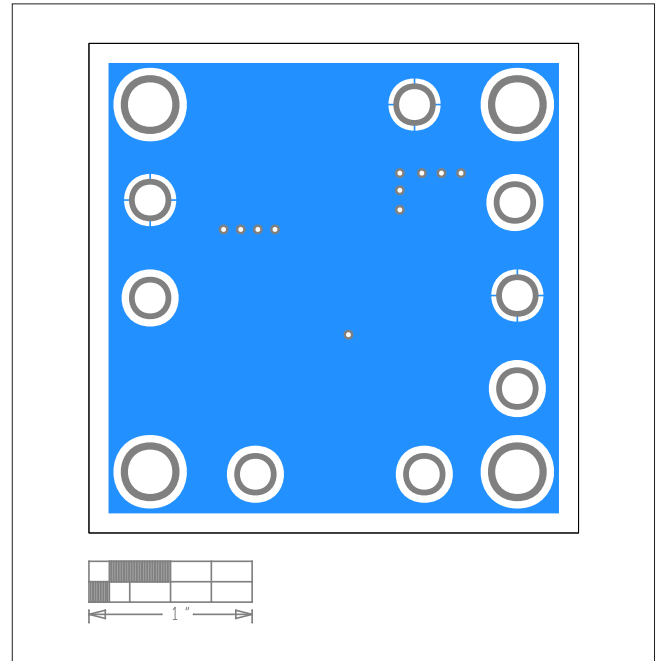

MAX6226 EV Kit PCB Layout—Bottom Layer

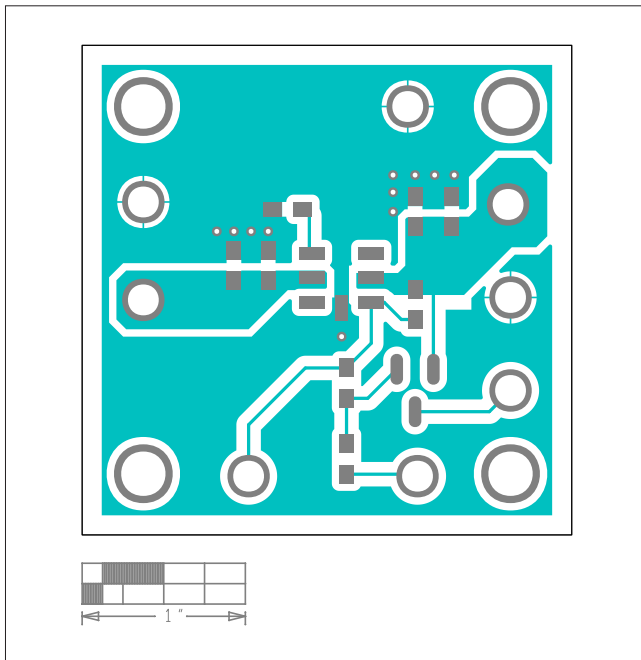

MAX6226 EV Kit PCB Layout—Top Layer

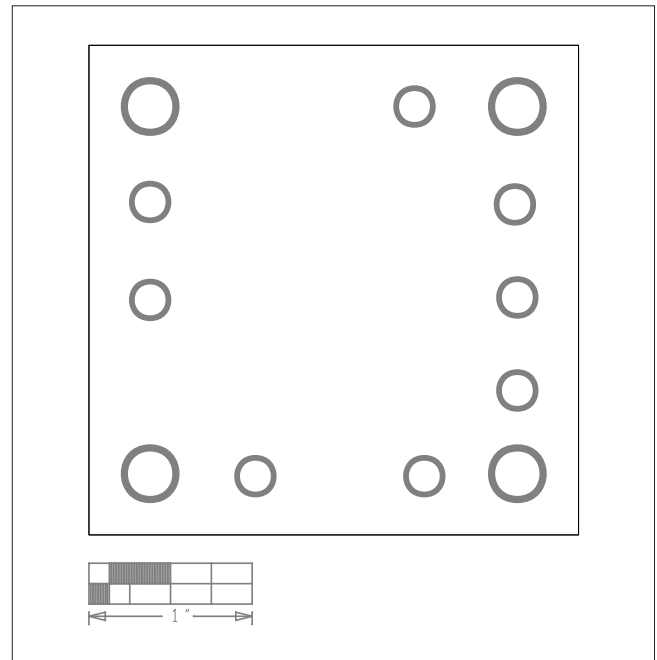

MAX6226 EV Kit Component Placement Guide—Bottom Silkscreen

Revision History

REVISION NUMBER	REVISION DATE	DESCRIPTION	PAGES CHANGED
0	12/18	Initial release	—
1	11/21	Updated <i>General Description</i> , <i>EV Kit Photo</i> , <i>MAX6226 EV Kit Bill of Materials</i> , <i>MAX6226 EV Kit Schematic</i> , and <i>MAX6226 EV Kit PCB Layouts</i>	1–4



Information furnished by Analog Devices is believed to be accurate and reliable. However, no responsibility is assumed by Analog Devices for its use, nor for any infringements of patents or other rights of third parties that may result from its use. Specifications subject to change without notice. No license is granted by implication or otherwise under any patent or patent rights of Analog Devices. Trademarks and registered trademarks are the property of their respective owners.

X-ON Electronics

Largest Supplier of Electrical and Electronic Components

Click to view similar products for [Power Management IC Development Tools](#) category:

Click to view products by [Maxim](#) manufacturer:

Other Similar products are found below :

[EVB-EP5348UI](#) [MIC23451-AAAYFL EV](#) [MIC5281YMME EV](#) [124352-HMC860LP3E](#) [DA9063-EVAL](#) [ADP122-3.3-EVALZ](#) [ADP130-0.8-EVALZ](#) [ADP130-1.8-EVALZ](#) [ADP1740-1.5-EVALZ](#) [ADP1870-0.3-EVALZ](#) [ADP1874-0.3-EVALZ](#) [ADP199CB-EVALZ](#) [ADP2102-1.25-EVALZ](#) [ADP2102-1.875EVALZ](#) [ADP2102-1.8-EVALZ](#) [ADP2102-2-EVALZ](#) [ADP2102-3-EVALZ](#) [ADP2102-4-EVALZ](#) [AS3606-DB](#) [BQ25010EVM](#) [BQ3055EVM](#) [ISLUSBI2CKIT1Z](#) [LP38512TS-1.8EV](#) [EVAL-ADM1186-1MBZ](#) [EVAL-ADM1186-2MBZ](#) [ADP122UJZ-REDYKIT](#) [ADP166Z-REDYKIT](#) [ADP170-1.8-EVALZ](#) [ADP171-EVALZ](#) [ADP1853-EVALZ](#) [ADP1873-0.3-EVALZ](#) [ADP198CP-EVALZ](#) [ADP2102-1.0-EVALZ](#) [ADP2102-1-EVALZ](#) [ADP2107-1.8-EVALZ](#) [ADP5020CP-EVALZ](#) [CC-ACC-DBMX-51](#) [ATPL230A-EK](#) [MIC23250-S4YMT EV](#) [MIC26603YJL EV](#) [MIC33050-SYHL EV](#) [TPS60100EVM-131](#) [TPS65010EVM-230](#) [TPS71933-28EVM-213](#) [TPS72728YFFEVM-407](#) [TPS79318YEQEVM](#) [UCC28810EVM-002](#) [XILINXPWR-083](#) [LMR22007YMINI-EVM](#) [LP38501ATJ-EV](#)