

MAX6394

High-Accuracy μ P Reset Circuit

General Description

The MAX6394 low-power CMOS microprocessor (μ P) supervisory circuit is designed to monitor power supplies in μ P and digital systems. It offers excellent circuit reliability by providing 1% accurate thresholds over temperature and by eliminating external components and adjustments. The MAX6394 also provides a debounced manual reset input.

This device performs a single function: it asserts a reset signal whenever the V_{CC} supply voltage falls below a preset threshold or whenever manual reset is asserted. $\overline{\text{RESET}}$ remains asserted for an internally programmed interval (reset timeout period) after V_{CC} has risen above the reset threshold or manual reset is deasserted. The MAX6394's open-drain $\overline{\text{RESET}}$ output can be pulled up to a voltage higher than V_{CC} .

The MAX6394 comes with factory-trimmed reset threshold voltages from 2.4V to 4.8V. Preset timeout periods of 0.7ms, 14ms, 105ms, and 826ms are also available. The device comes in a SOT143 package.

Applications

- Computers
- Controllers
- Intelligent Instruments
- Critical μ P and μ C Power Monitoring
- Portable/Battery-Powered Equipment

Benefits and Features

- $\pm 0.6\%$ Threshold Accuracy at $T_A = +25^\circ\text{C}$
- $\pm 1.0\%$ Threshold Accuracy from -40°C to $+125^\circ\text{C}$
- Small SOT143 Package
- Open-Drain $\overline{\text{RESET}}$ Output Can Exceed V_{CC}
- Precision, Factory-Set V_{CC} Reset Thresholds: Nine Options from 2.4V to 4.8V
- Four Reset Timeout Periods Available: 0.7ms, 14ms, 105ms, and 826ms (minimum)
- Immune to Short V_{CC} Transients
- 5 μ A Supply Current
- AEC-Q100 Qualified, Refer to [Ordering Information](#) for Specific I/V Part

[Ordering Information](#) appears at end of data sheet.

Pin Configuration

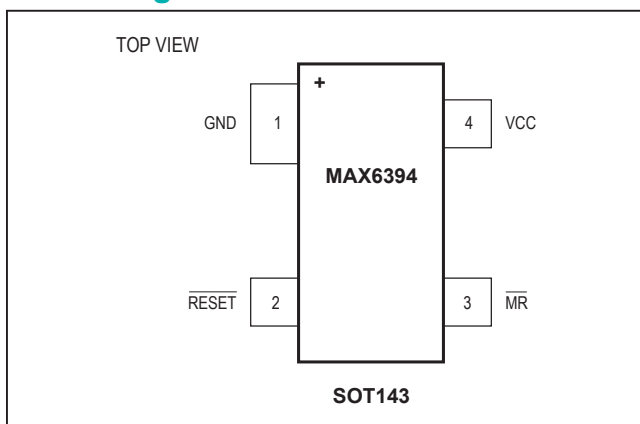

Typical Operating Circuit

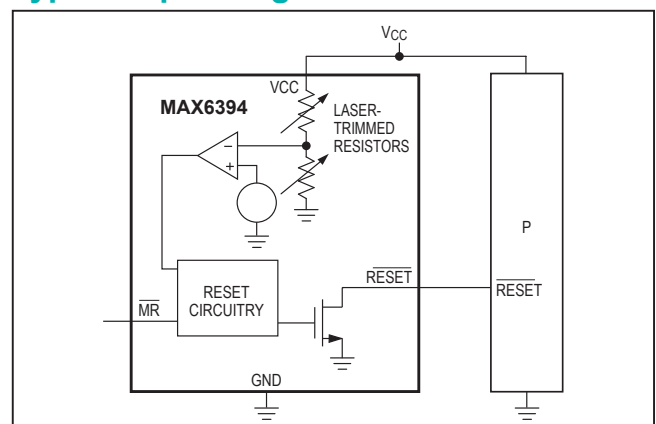

Absolute Maximum Ratings

VCC.....	-0.3V to +6.0V	Continuous Power Dissipation ($T_A = +70^\circ\text{C}$)	
RESET.....	-0.3V to +6.0V	SOT143 (derate 3.4mW/ $^\circ\text{C}$ above $+70^\circ\text{C}$).....	275.9mW
All Other Pins.....	-0.3V to ($V_{CC} + 0.3\text{V}$)	Operating Temperature Range.....	-40°C to $+125^\circ\text{C}$
Input Current (V_{CC}).....	20mA	Storage Temperature Range.....	-65°C to $+160^\circ\text{C}$
Output Current (RESET).....	20mA	Lead Temperature (soldering, 10s).....	$+300^\circ\text{C}$
Rate of Rise (V_{CC}).....	100V/ μs		

Stresses beyond those listed under "Absolute Maximum Ratings" may cause permanent damage to the device. These are stress ratings only, and functional operation of the device at these or any other conditions beyond those indicated in the operational sections of the specifications is not implied. Exposure to absolute maximum rating conditions for extended periods may affect device reliability.

Package Information

4 SOT23

PACKAGE CODE	U4+1/U4+1A
Outline Number	21-0052
Land Pattern Number	90-0183
Thermal Resistance, Single-Layer Board	
Junction to Ambient (θ_{JA})	N/A
Junction to Case (θ_{JC})	N/A
Thermal Resistance, Four-Layer Board	
Junction to Ambient (θ_{JA})	290
Junction to Case (θ_{JC})	100

For the latest package outline information and land patterns (footprints), go to www.maximintegrated.com/packages. Note that a "+", "#", or "-" in the package code indicates RoHS status only. Package drawings may show a different suffix character, but the drawing pertains to the package regardless of RoHS status.

Package thermal resistances were obtained using the method described in JEDEC specification JESD51-7, using a four-layer board. For detailed information on package thermal considerations, refer to www.maximintegrated.com/thermal-tutorial.

Electrical Characteristics

($V_{CC} = +2.4V$ to $+5.5V$, $T_A = -40^\circ C$ to $+125^\circ C$, unless otherwise noted. Typical values are at $T_A = +25^\circ C$.)

PARAMETER	SYMBOL	CONDITIONS	MIN	TYP	MAX	UNITS
Operating Voltage Range	V_{CC}	$T_A = -40^\circ C$ to $+125^\circ C$	1.0		5.5	V
V_{CC} Supply Current	I_{CC}	$V_{CC} = 5.5V$, no load ($-40^\circ C$ to $+85^\circ C$)		5	12	μA
		$V_{CC} = 5.5V$, no load ($-40^\circ C$ to $+125^\circ C$)			15	
		$V_{CC} = 3.6V$, no load ($-40^\circ C$ to $+85^\circ C$)		4	10	
		$V_{CC} = 3.6V$, no load ($-40^\circ C$ to $+125^\circ C$)			12	
Reset Threshold (Note 1)	V_{TH}	$T_A = +25^\circ C$ (see Table 1)	$V_{TH} - 0.6\%$	V_{TH}	$V_{TH} + 0.6\%$	V
		$T_A = -40^\circ C$ to $+125^\circ C$ (see Table 2)	$V_{TH} - 1.0\%$		$V_{TH} + 1.0\%$	
Reset Threshold Tempco	$\Delta V_{TH}/^\circ C$			60		ppm/ $^\circ C$
V_{CC} to Reset Delay		$V_{CC} =$ falling at $1mV/\mu s$		35		μs
Reset Timeout Period	t_{RP}	MAX6394US__D1+T	0.7	1.4	2.0	ms
		MAX6394US__D2-T	14	28	40	
		MAX6394US__D3-T	105	200	280	
		MAX6394US__D4-T	826	1570	2240	
MANUAL RESET INPUT						
\overline{MR} Input Threshold	V_{IL}	$V_{TH} > 4.0V$	0.8			V
	V_{IH}			2.4		
	V_{IL}	$V_{TH} < 4.0V$	$0.3 \times V_{CC}$			
	V_{IH}			$0.7 \times V_{CC}$		
\overline{MR} Minimum Input Pulse			1			μs
\overline{MR} Glitch Rejection				100		ns
\overline{MR} to Reset Delay				500		ns
\overline{MR} Pullup Resistance			32	63	100	k Ω
\overline{RESET} Output Voltage	V_{OL}	$V_{CC} > 4.25V$, $I_{SINK} = 3.2mA$			0.4	V
		$V_{CC} > 2.5V$, $I_{SINK} = 1.2mA$			0.3	
		$V_{CC} > 1.2V$, $I_{SINK} = 0.5mA$			0.3	
		$V_{CC} > 1.0V$, $I_{SINK} = 80\mu A$			0.3	
\overline{RESET} Output Leakage Current		$V_{CC} > V_{TH}$, \overline{RESET} deasserted			1	μA

Note 1: The MAX6394 monitors V_{CC} through an internal factory-trimmed voltage-divider that programs the nominal reset threshold. Other thresholds may be available. Contact factory for availability.

Typical Operating Characteristics

($T_A = +25^\circ\text{C}$, unless otherwise noted.)

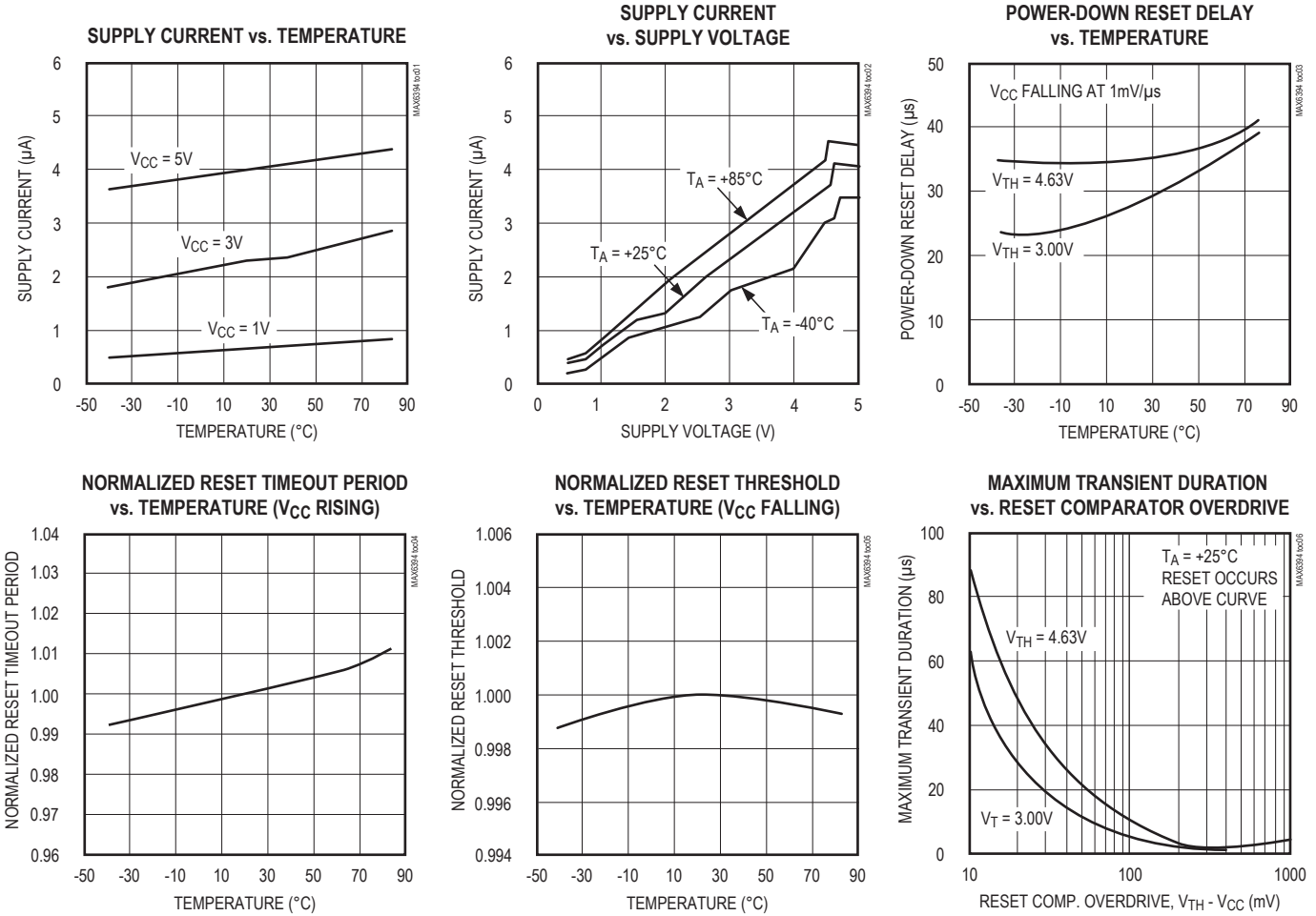

Pin Description

PIN	NAME	FUNCTION
1	GND	Ground
2	$\overline{\text{RESET}}$	Active-Low Open-Drain Output. Connect to an external pullup resistor. Can be pulled up to a voltage higher than V_{CC} , but less than 6V .
3	$\overline{\text{MR}}$	Manual Reset Input. A logic-low on $\overline{\text{MR}}$ asserts reset. Reset remains asserted as long as $\overline{\text{MR}}$ is low, and for the reset timeout period (t_{RP}) after the reset conditions are terminated. Connect to V_{CC} if not used.
4	VCC	Supply Voltage and Reset Threshold Monitor Input

Detailed Description

Reset Output

A microprocessor's (μ P's) reset input starts the μ P in a known state. The MAX6394 asserts a reset signal to prevent code-execution errors during power-up, power-down, or brownout conditions. $\overline{\text{RESET}}$ is guaranteed to be a logic-low for $V_{\text{CC}} > 1\text{V}$ (see the *Electrical Characteristics* table). Once V_{CC} exceeds the reset threshold, the internal timer keeps $\overline{\text{RESET}}$ asserted for the reset timeout period (t_{RP}); after this interval $\overline{\text{RESET}}$ goes high. If a brownout condition occurs (monitored voltage dips below its programmed reset threshold), $\overline{\text{RESET}}$ goes low. Any time V_{CC} dips below the reset threshold, the internal timer resets to zero and $\overline{\text{RESET}}$ goes low. The internal timer starts when V_{CC} returns above the reset threshold, and $\overline{\text{RESET}}$ remains low for the reset timeout period.

The MAX6394's $\overline{\text{RESET}}$ output structure is a simple open-drain n-channel MOSFET switch. Connect a pullup resistor to any supply in the 0 to +6V range. Select a resistor value large enough to register a logic-low when $\overline{\text{RESET}}$ is asserted (see the *Electrical Characteristics* table), and small enough to register a logic-high while supplying all input current and leakage paths connected to the $\overline{\text{RESET}}$ line. A 10k Ω pullup is sufficient in most applications.

Often, the pullup connected to the MAX6394's $\overline{\text{RESET}}$ output connects to the supply voltage monitored at the IC's V_{CC} pin. However, some systems may use the open-drain output to level-shift from the monitored supply to reset circuitry powered by some other supply (Figure 1). This is one useful feature of an open-drain output. Keep in mind that as the MAX6394's V_{CC} decreases below 1V, so does the IC's ability to sink current at $\overline{\text{RESET}}$. Finally, with any pullup, $\overline{\text{RESET}}$ is pulled high as V_{CC} decays toward 0V. The voltage where this occurs depends on the pullup resistor value and the voltage to which it connects (see the *Electrical Characteristics* table).

Manual-Reset Input

Many μ P-based products require manual-reset capability, allowing the operator, a test technician, or external logic circuitry to initiate a reset. A logic-low on $\overline{\text{MR}}$ asserts reset. $\overline{\text{RESET}}$ remains asserted while $\overline{\text{MR}}$ is low, and for the reset active timeout period after $\overline{\text{MR}}$ returns high.

$\overline{\text{MR}}$ has an internal 63k Ω pullup resistor, so it can be left open if not used. Connect a normally open momentary

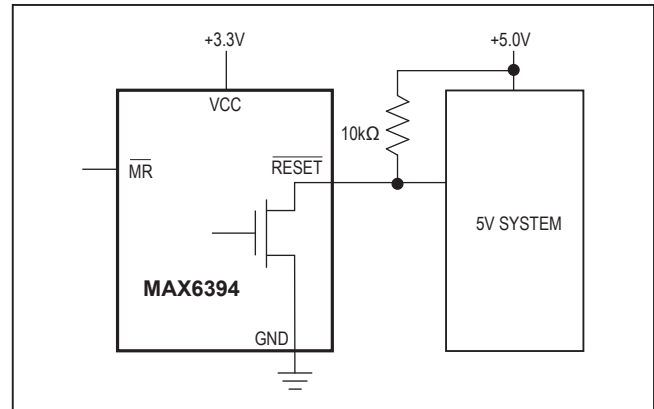

Figure 1. MAX6394 Open-Drain $\overline{\text{RESET}}$ Output Allows Use with Multiple Supplies

switch from $\overline{\text{MR}}$ to GND to create a manual reset function; external debounce circuitry is not required. If $\overline{\text{MR}}$ is driven from long cables or if the device is used in a noisy environment, connecting a 0.1 μ F capacitor from $\overline{\text{MR}}$ to ground provides additional noise immunity.

Applications Information

Negative-Going V_{CC} Transients

In addition to issuing a reset to the μ P during power-up, power-down, and brownout conditions, these devices are relatively immune to short-duration negative-going transients (glitches). The *Typical Operating Characteristics* show the Maximum Transient Duration vs. Reset Threshold Overdrive, for which reset pulses are not generated. The graph was produced using negative-going pulses, starting at $V_{\text{RST max}}$ and ending below the programmed reset threshold by the magnitude indicated (reset threshold overdrive). The graph shows the maximum pulse width that a negative-going V_{CC} transient may typically have without causing a reset pulse to be issued. As the transient amplitude increases (i.e., goes farther below the reset threshold), the maximum allowable pulse width decreases. A 0.1 μ F bypass capacitor mounted close to V_{CC} provides additional transient immunity.

Chip Information

TRANSISTOR COUNT: 529

Table 1. $\pm 0.6\%$ of Thresholds

$\pm 0.6\%$ OF THRESHOLD (V)			
SUFFIX	MIN	TYP	MAX
480	4.771	4.800	4.829
470	4.672	4.700	4.728
455	4.523	4.550	4.577
445	4.423	4.450	4.477
317	3.149	3.168	3.187
310	3.083	3.102	3.121
300	2.985	3.003	3.021
294	2.919	2.937	2.955
240	2.386	2.400	2.414

Timeout Options

SUFFIX	MIN (ms)	TYP (ms)	MAX (ms)
D1	0.7	1.4	2
D2	14	28	40
D3	105	200	280
D4	826	1570	2240

Table 2. $\pm 1\%$ of Thresholds

$\pm 1\%$ OF THRESHOLD (V)			
SUFFIX	MIN	TYP	MAX
480	4.752	4.800	4.848
470	4.653	4.700	4.747
455	4.505	4.550	4.596
445	4.406	4.450	4.495
317	3.136	3.168	3.200
310	3.071	3.102	3.133
300	2.973	3.003	3.033
294	2.908	2.937	2.966
240	2.376	2.400	2.424

**Standard Versions
Selector Guide**

STANDARD VERSIONS	
480	D3
455	
310	
240	

Note: Samples are generally available in standard versions. Contact factory for availability of nonstandard versions.

Ordering Information

PART	TEMPERATURE RANGE	PIN-PACKAGE
MAX6394US__D_+T	-40°C to +125°C	4 SOT143-4
MAX6394US__D_/V+T	-40°C to +125°C	4 SOT143-4
MAX6394US317D2/V+T	-40°C to +125°C	4 SOT143-4
MAX6394US480D1/V+T	-40°C to +125°C	4 SOT143-4
MAX6394US480D3/V+T	-40°C to +125°C	4 SOT143-4

Note: This device is specified over the -40°C to +125°C operating temperature range.

+Denotes a lead-free package.

Note: The “__” is a placeholder for the input voltage thresholds. Nine threshold options are available. See Tables 1 and 2 for more information.

Note: The “_” is a placeholder for the timeout option. Four options are available. See the Timeout Options section for more information.

Four standard versions are available (see the Standard Versions Selector Guide section). Samples are generally available in standard versions. Contact factory for availability of nonstandard versions.

Note: All devices are available in tape-and-reel only. Tape and reel is offered in 2.5k increments.

Revision History

REVISION NUMBER	REVISION DATE	DESCRIPTION	PAGES CHANGED
0	1/08	Initial release	—
1	12/15	Added lead-free part numbers and added MAX6394US___/V+T	1, 2
2	3/18	Added Package Information section	2
3	3/18	Updated <i>Ordering Information</i> and <i>Benefits and Features</i>	1, 6
4	8/19	Updated <i>Package Information</i> section	2
5	12/19	Updated <i>Chip Information</i>	5

For pricing, delivery, and ordering information, please visit Maxim Integrated's online storefront at <https://www.maximintegrated.com/en/storefront/storefront.html>.

Maxim Integrated cannot assume responsibility for use of any circuitry other than circuitry entirely embodied in a Maxim Integrated product. No circuit patent licenses are implied. Maxim Integrated reserves the right to change the circuitry and specifications without notice at any time. The parametric values (min and max limits) shown in the Electrical Characteristics table are guaranteed. Other parametric values quoted in this data sheet are provided for guidance.

X-ON Electronics

Largest Supplier of Electrical and Electronic Components

Click to view similar products for [Supervisory Circuits](#) category:

Click to view products by [Maxim](#) manufacturer:

Other Similar products are found below :

[CAT1161LI-25-G](#) [CAT853STBI-T3](#) [CAT1026LI-30-G](#) [CAT1320LI-25-G](#) [TC54VN2402EMB713](#) [MCP1316T-44NE/OT](#) [MCP1316MT-45GE/OT](#) [MCP1316MT-23LI/OT](#) [MAX8997EWW+](#) [MAX6725AKASYD3-LF-T](#) [DS1232L](#) [NCV302HSN45T1G](#) [PT7M6130NLTA3EX](#) [PT7M7811STBEX-2017](#) [S-1000N28-I4T1U](#) [CAT1161LI-28-G](#) [MCP1321T-29AE/OT](#) [MCP1319MT-47QE/OT](#) [S-1000N23-I4T1U](#) [S-1000N19-I4T1U](#) [CAT824UTDI-GT3](#) [TC54VC2502ECB713](#) [PT7M6133NLTA3EX](#) [PT7M6127NLTA3EX](#) [AP0809ES3-r](#) [HG811RM4/TR](#) [MD7030C](#) [MD7033C](#) [MD7019](#) [MD7020](#) [MD7021](#) [MD7023](#) [MD7024](#) [MD7027](#) [MD7030](#) [MD7033](#) [MD7035](#) [MD7036](#) [MD7039](#) [MD7040](#) [MD7044](#) [MD7050](#) [MD7015](#) [MD7022](#) [MD7028](#) [MD7031](#) [MD7042](#) [MD7043](#) [MD7047](#) [MD7060](#)