

MAX6576/MAX6577

SOT Temperature Sensors with Period/Frequency Output

General Description

The MAX6576/MAX6577 are low-cost, low-current temperature sensors with a single-wire output. The MAX6576 converts the ambient temperature into a square wave with a period proportional to absolute temperature ($^{\circ}\text{K}$). The MAX6577 converts the ambient temperature into a square wave with a frequency proportional to absolute temperature. The MAX6576 offers accuracy of $\pm 3^{\circ}\text{C}$ at $+25^{\circ}\text{C}$, $\pm 4.5^{\circ}\text{C}$ at $+85^{\circ}\text{C}$, and $\pm 5^{\circ}\text{C}$ at $+125^{\circ}\text{C}$. The MAX6577 offers accuracy of $\pm 3^{\circ}\text{C}$ at $+25^{\circ}\text{C}$, $\pm 3.5^{\circ}\text{C}$ at $+85^{\circ}\text{C}$, and $\pm 4.5^{\circ}\text{C}$ at $+125^{\circ}\text{C}$.

Both devices feature a single-wire output that minimizes the number of pins necessary to interface with a microprocessor. The period/frequency range of the output square wave can be selected by hard-wiring the two time-select pins (TS0, TS1) to either V_{DD} or GND. The MAX6576/MAX6577 are available in space-saving 6-pin SOT23 packages.

Applications

- Critical μP and μC Temperature Monitoring
- Portable Battery-Powered Equipment
- Cell Phones
- Battery Packs
- Hard Drives/Tape Drives
- Networking and Telecom Equipment
- Medical Equipment

Pin Configuration

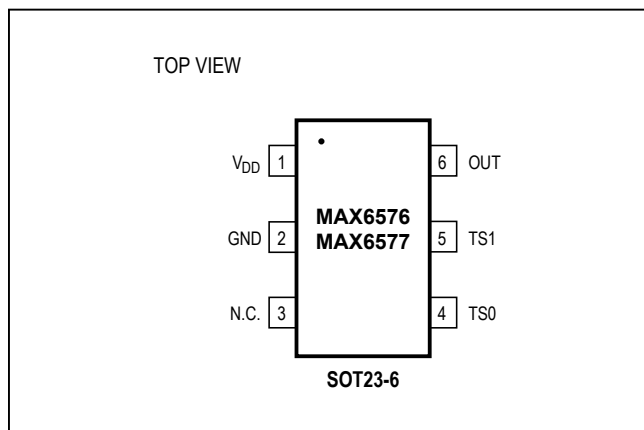

Features

- Simple Single-Wire Output
- Two Output Types Available
 - Temperature to Period (μs) (MAX6576)
 - Temperature to Frequency (Hz) (MAX6577)
- $\pm 0.8^{\circ}\text{C}$ Accuracy at $+25^{\circ}\text{C}$ ($\pm 3^{\circ}\text{C}$ max)
- No External Components
- Operates from $+2.7\text{V}$ to $+5.5\text{V}$ Supply Voltage
- Low $140\mu\text{A}$ Typical Supply Current
- Standard Operating Temperature Range: -40°C to $+125^{\circ}\text{C}$
- Small 6-Pin SOT23 Package

Ordering Information

PART	TEMP. RANGE	PIN-PACKAGE	SOT TOP MARK
MAX6576ZUT	-40°C to $+125^{\circ}\text{C}$	6 SOT23	AABI
MAX6577ZUT	-40°C to $+125^{\circ}\text{C}$	6 SOT23	AABJ

Typical Operating Circuit

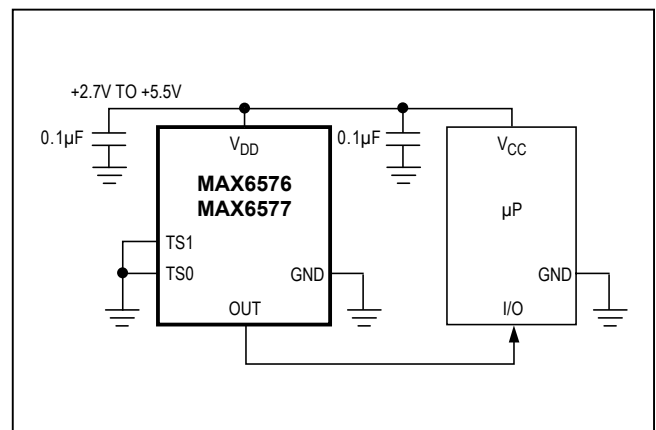

Absolute Maximum Ratings

Terminal Voltage (with respect to GND)
 V_{DD}.....-0.3V to +6V
 TS1, TS0, OUT.....-0.3V to (V_{DD} + 0.3V)
 Input/Output Current, All Pins.....±20mA
 Continuous Power Dissipation (T_A = +70°C)
 6-pin SOT23 (derate 7.10mW/°C above +70°C).....571mW

Operating Temperature Range.....-40°C to +125°C
 Storage Temperature Range.....-65°C to +150°C
 Lead Temperature (soldering, 10sec).....+300°C

Stresses beyond those listed under "Absolute Maximum Ratings" may cause permanent damage to the device. These are stress ratings only, and functional operation of the device at these or any other conditions beyond those indicated in the operational sections of the specifications is not implied. Exposure to absolute maximum rating conditions for extended periods may affect device reliability.

Electrical Characteristics

(V_{DD} = +2.7V to +5.5V, T_A = -40°C to +125°C, unless otherwise noted. Typical values are specified at T_A = +25°C and V_{DD} = +5V, unless otherwise noted.)

PARAMETER	SYMBOL	CONDITIONS		MIN	TYP	MAX	UNITS
V _{DD} Range	V _{DD}			2.7		5.5	V
Supply Current	I _{DD}	V _{DD} = 5.5V	T _A = -40°C to +85°C		140	250	µA
			T _A = -40°C to +125°C			400	
Temperature Sensor Error (Note 1)		MAX6576	T _A = -20°C	-7.5	±1.1	+7.5	°C
			T _A = 0°C	-5.5	±0.9	+5.5	
			T _A = +25°C	-3.0	±0.8	+3.0	
			T _A = +85°C	-4.5	±0.5	+4.5	
			T _A = +125°C	-5.0	±0.5	+5.0	
		MAX6577	T _A = -20°C	-7.5	±1.1	+7.5	°C
			T _A = 0°C	-6.5	±0.9	+6.5	
			T _A = +25°C	-3.0	±0.8	+3.0	
			T _A = +85°C	-3.5	±0.5	+3.5	
			T _A = +125°C	-4.5	±0.5	+4.5	
Output Clock Period	t _{OUT}	MAX6576, T (temp) in °K, Figure 1	V _{TS1} = GND, V _{TS0} = GND		10T	µs	
			V _{TS1} = GND, V _{TS0} = V _{DD}		40T		
			V _{TS1} = V _{DD} , V _{TS0} = GND		160T		
			V _{TS1} = V _{DD} , V _{TS0} = V _{DD}		640T		
Output Clock Frequency	f _{OUT}	MAX6577, T (temp) in °K, Figure 2	V _{TS1} = GND, V _{TS0} = GND		4T	Hz	
			V _{TS1} = GND, V _{TS0} = V _{DD}		1T		
			V _{TS1} = V _{DD} , V _{TS0} = GND		T/4		
			V _{TS1} = V _{DD} , V _{TS0} = V _{DD}		T/16		
OUT Duty Cycle (Note 2)					0.5		
Time-Select Pin Logic Levels	V _{IL}					0.8	V
	V _{IH}			2.3			
OUT Voltage	V _{OL}		V _{DD} > 4.5V, I _{SINK} = 3.2mA			0.4	V
			V _{DD} > 2.7V, I _{SINK} = 1.2mA			0.3	
	V _{OH}		V _{DD} > 4.5V, I _{SRC} = 800µA	V _{DD} - 1.5			
			V _{DD} > 2.7V, I _{SRC} = 500µA	0.8V _{DD}			

Note 1: See the Temperature Accuracy histograms in the *Typical Operating Characteristics*.

Note 2: The output duty cycle is guaranteed to be 50% by an internal flip-flop.

Typical Operating Characteristics

($V_{DD} = +5V$, $T_A = +25^\circ C$, unless otherwise noted.)

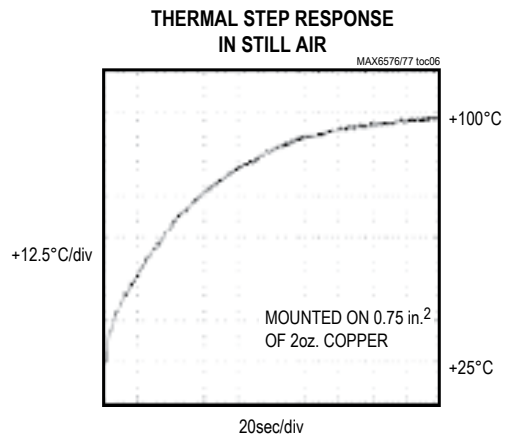
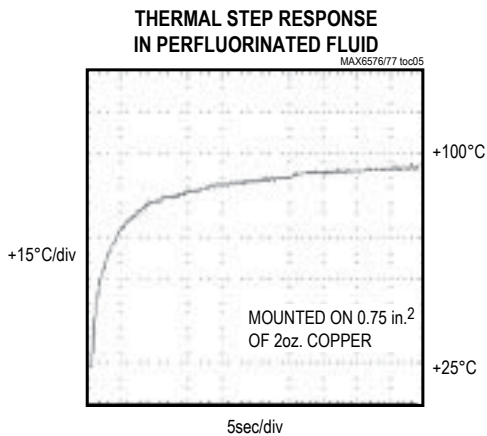
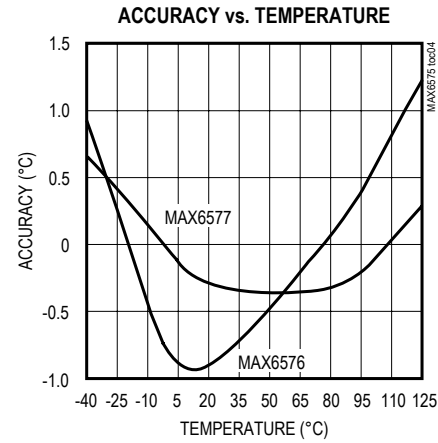
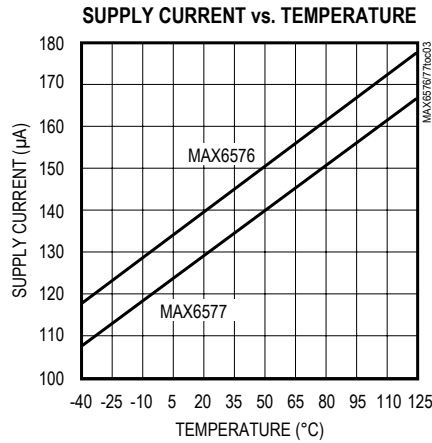
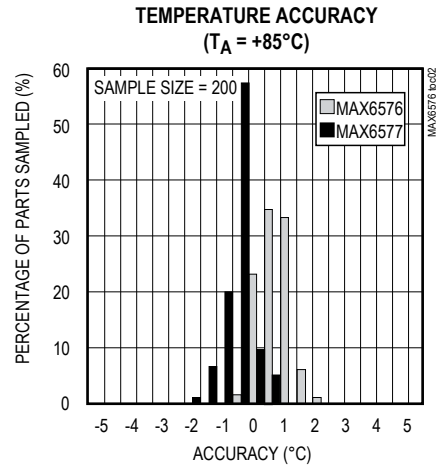
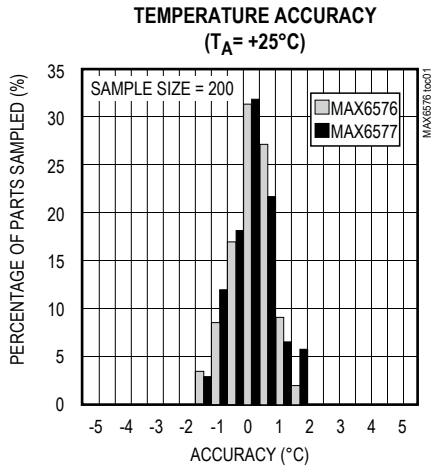

Pin Description

PIN	NAME	FUNCTION
1	V _{DD}	Positive Supply Voltage
2	GND	Ground
3	N.C.	No Connection. Connect pin to GND or leave open.
4, 5	TS1, TS0	Time-Select Pins. TS1 and TS0 set the temperature scale factor by connecting TS1 and TS0 to either V _{DD} or GND. See Tables 1 and 2.
6	OUT	Square-Wave Output with a Clock Period Proportional to Absolute Temperature (°K) (MAX6576)
		Square-Wave Output with a Clock Frequency Proportional to Absolute Temperature (°K) (MAX6577)

Table 1. MAX6576 Time-Select Pin Configuration

TS1	TS0	SCALAR MULTIPLIER (μs/°K)
GND	GND	10
GND	V _{DD}	40
V _{DD}	GND	160
V _{DD}	V _{DD}	640

Note: The temperature, in °C, may be calculated as follows:

$$T(^{\circ}\text{C}) = \frac{\text{PERIOD}(\mu\text{s})}{\text{SCALAR MULTIPLIER}(\mu\text{s}/^{\circ}\text{K})} - 273.15^{\circ}\text{K}$$

Detailed Description

The MAX6576/MAX6577 low-cost, low-current (140μA typ) temperature sensors are ideal for interfacing with microcontrollers (μCs) or microprocessors (μPs). The MAX6576 converts ambient temperature into a 50% duty-cycle square wave with a period proportional to absolute temperature. The MAX6577 converts ambient temperature into a 50% duty-cycle square wave with a frequency proportional to absolute temperature. Time-select pins (TS1, TS0) permit the internal temperature-controlled oscillator (TCO) to be scaled by four preset multipliers. The MAX6576/MAX6577 feature a single-wire interface to minimize the number of port pins necessary for interfacing with a μP.

MAX6576 Characteristics

The MAX6576 temperature sensor converts temperature to period. The output of the device is a free-running, 50% duty-cycle square wave with a period that is proportional

Table 2. MAX6577 Time-Select Pin Configuration

TS1	TS0	SCALAR MULTIPLIER (Hz/°K)
GND	GND	4
GND	V _{DD}	1
V _{DD}	GND	1/4
V _{DD}	V _{DD}	1/16

Note: The temperature, in °C, may be calculated as follows:

$$T(^{\circ}\text{C}) = \frac{\text{FREQUENCY}(\mu\text{s})}{\text{SCALAR MULTIPLIER}(\mu\text{s}/^{\circ}\text{K})} - 273.15^{\circ}\text{K}$$

to the absolute temperature (°K) of the device (Figure 1). The MAX6576 has a push/pull CMOS output with sharp edges. The speed of the output square wave can be selected by hard-wiring TS1 and TS0 as shown in Table 1. One of four scaled output periods can be selected using TS1 and TS0.

MAX6577 Characteristics

The MAX6577 temperature sensor converts temperature to frequency. The output of the device is a free-running, 50% duty-cycle square wave with a frequency that is proportional to the absolute temperature (°K) of the device (Figure 2). The MAX6577 has a push/pull CMOS output with sharp edges. The speed of the output square wave can be selected by hard-wiring TS1 and TS0 as shown in Table 2. One of four scaled output frequencies can be selected using TS1 and TS0.

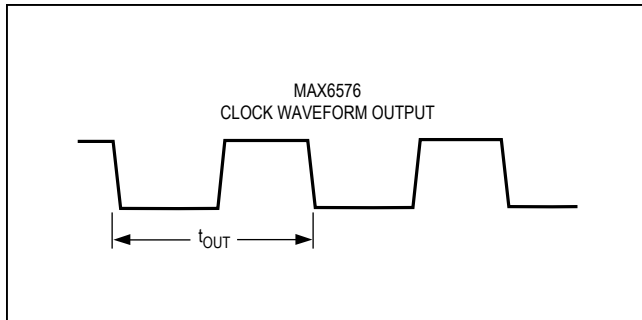

Figure 1. MAX6576 Timing Diagram

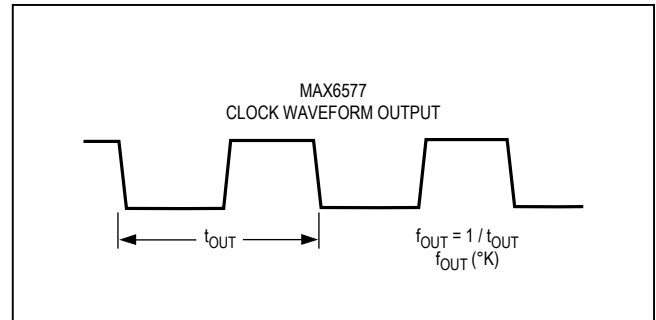

Figure 2. MAX6577 Timing Diagram

Applications Information

Quick-Look Circuits

Figure 3 shows a quick-look application circuit for the MAX6576 using a universal counter measuring period. TS1 and TS0 are both tied to ground to select a scalar multiplier of $10\mu\text{s}/^\circ\text{K}$. The MAX6576 converts the ambient temperature into a square wave with a period that is 10 times the absolute temperature of the device in μs . At room temperature, the universal counter will display approximately $2980\mu\text{s}$.

Figure 4 shows a quick-look application circuit for the MAX6577 using a universal counter measuring frequency. TS1 is tied to ground and TS0 is tied to V_{DD} to select a scalar multiplier of $1\text{Hz}/^\circ\text{K}$. The MAX6577 converts the ambient temperature into a square wave with a frequency that is equal to the absolute temperature of the device in Hertz. At room temperature, the universal counter will display approximately 298Hz.

Interfacing with a Microcontroller

Figure 5 shows the MAX6577 interfaced with an 8051 μC . In this example, TS1 is tied to ground and TS0 is tied to

V_{DD} to select a scalar multiplier of $1\text{Hz}/^\circ\text{K}$. The MAX6577 converts the ambient temperature into a square wave with a frequency that is equal to the absolute temperature of the device in Hertz. The 8051 μC reads the frequency of the square-wave output of the MAX6577 into Timer 0 and displays the temperature as degrees Celsius in binary on Port 1. Listing 1 provides the code for this application. The interface is similar for the MAX6576, except the μC will perform a period measurement.

Noise Considerations

The accuracy of the MAX6576/MAX6577 is susceptible to noise generated both internally and externally. The effects of external noise can be minimized by placing a $0.1\mu\text{F}$ ceramic bypass capacitor close to the supply pin of the devices. Internal noise is inherent in the operation of the devices and is detailed in Table 3. Internal averaging minimizes the effect of this noise when using longer scalar timeout multipliers. The effects of this noise are included in the overall accuracy of the devices as specified in the *Electrical Characteristics*.

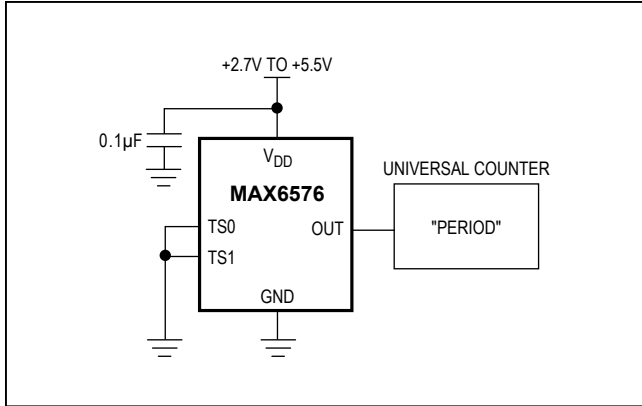

Figure 3. MAX6576 Quick-Look Circuit

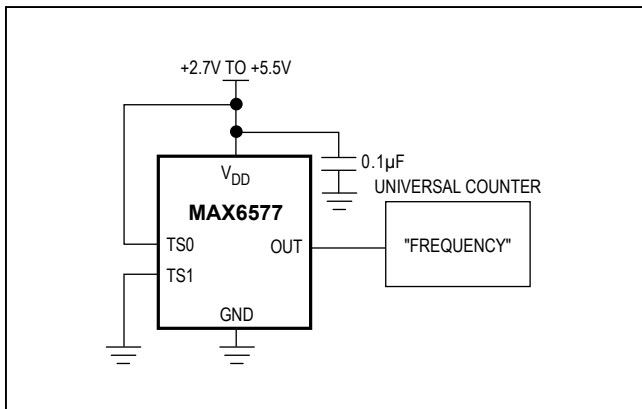

Figure 4. MAX6577 Quick-Look Circuit

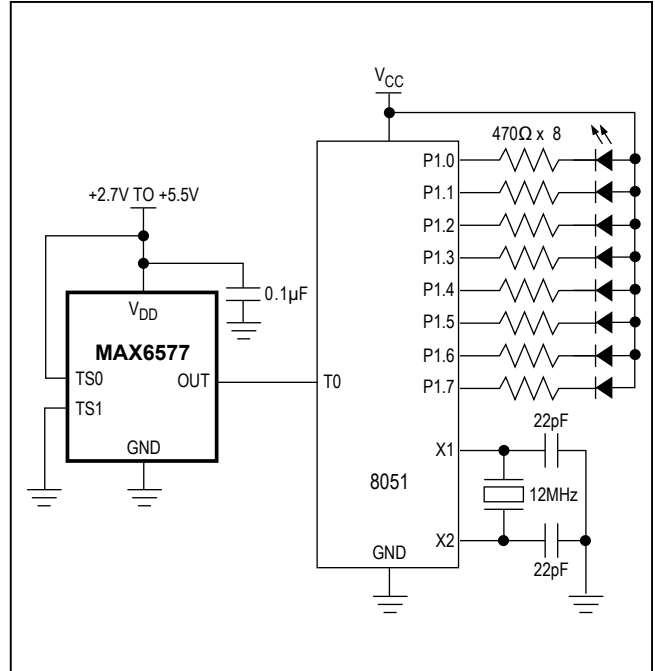

Figure 5. Interfacing with a µC

Chip Information
TRANSISTOR COUNT: 302

Table 3. Typical Peak Noise Amplitude

PARAMETER	MAX6576				MAX6577			
	10	40	160	640	4	1	1/4	1/16
Scalar Multiplier	10	40	160	640	4	1	1/4	1/16
Noise Amplitude (°C)	±0.38	±0.17	±0.11	±0.094	±0.13	±0.066	±0.040	±0.028

Listing 1. 8051 Code Example

```

;*****
; Demonstration and test code for MAX6577 Temp to Frequency
; Takes in temperature values from a sensor into timer 0
; and displays temp as degrees C in binary on port 1.
; example: room temp= 21 C, display 21 or 00010101 on P1
;*****
;EQUATES
TEMPH EQU 10H ;TEMPERATURE
TEMPL EQU 11H
TICKS EQU 12H ;number of 50 ms- counts to 1 second

NEWT BIT 00h ;new temp flag- bit address in 20h
;MAIN
ORG 0 ;note one isr's used- timer overflow
AJMP BEGIN ;jump over isr's
ORG 1BH ;TF1 ISR
TICK: PUSH ACC ;stash acc
      PUSH PSW ;stash psw
; reload timer- 50 ms
      CLR C ;clear for subb
      MOV A,#0B0H ;latency fix
      SUBB A,TL1 ;subtract timer low latency < 20
      MOV TL1,A ;50 ms reload value- low
      MOV TH1,#03CH ;50 ms reload value- high
      DJNZ TICKS,NORL ;jump over counter code
      MOV TICKS,#20 ;reload ticks
;read counter to templ and temp high if 1 second
GTAG: MOV A,TH0 ;get timer high
      MOV B,TL0 ;grab timer low
      CJNE A,TH0,GTAG ;get again if rollover
      MOV TEMPH,A ;stash high
      MOV TEMPL,B ;stash low
      MOV TH0,#0 ;zero counter
      MOV TL0,#0 ;zero counter
      SETB NEWT ;set data ready flag
NORL: POP PSW
      POP ACC
      RETI ;done

BEGIN: MOV SP,#70h ;set sp at 70H
;setup timers to do timing- t0 input, t1 timer 50 ms
      MOV TMOD,#15H ;t1 timer- t0 counter
      MOV TH1,#03CH ;50 ms reload value- high
      MOV TL1,#0B0H ;50 ms reload value- low
      MOV TL0,#0 ;reset counter low
      MOV TH0,#0 ;reset counter high
      MOV TCON,#50H ;start both timers
      MOV TICKS,#20 ;20 x 50 ms = 1 sec
      MOV IE,#88H ;enable t1 ints and global

;
;inits done- measure
DOTMP: CLR NEWT ;clear data flag
WAITT: JNB NEWT,WAITT ;wait for data

; temp is stored- display bin value of selected on P1

```

Listing 1. 8051 Code Example (continued)

```

; temp is in kelvin- subtract 273
MOV  A,TEMPL      ;get temp (K)
CLR  C            ;ready for subb
SUBB A,#011H     ;sub low byte of 273
MOV  TEMPL,A     ;stash back
MOV  A,TEMPH     ;get high byte for completeness
SUBB A,#01H      ;sub high byte and prop carry
MOV  TEMPH,A     ;stash
;display it
MOV  A,TEMPL     ;get temp (C)
CPL  A           ;compliment for led's- active low
MOV  P1,A        ;output it
JMP  DOTMP
END
    
```

Package Information

For the latest package outline information and land patterns (footprints), go to www.maximintegrated.com/packages. Note that a "+", "#", or "-" in the package code indicates RoHS status only. Package drawings may show a different suffix character, but the drawing pertains to the package regardless of RoHS status.

PACKAGE TYPE	PACKAGE CODE	OUTLINE NO.	LAND PATTERN NO.
6 SOT23	U6-4	21-0058	90-0175

Revision History

REVISION NUMBER	REVISION DATE	DESCRIPTION	PAGES CHANGED
0	4/99	Initial release	—
1	10/14	Removed automotive reference from data sheet	1

For pricing, delivery, and ordering information, please contact Maxim Direct at 1-888-629-4642, or visit Maxim Integrated's website at www.maximintegrated.com.

Maxim Integrated cannot assume responsibility for use of any circuitry other than circuitry entirely embodied in a Maxim Integrated product. No circuit patent licenses are implied. Maxim Integrated reserves the right to change the circuitry and specifications without notice at any time. The parametric values (min and max limits) shown in the Electrical Characteristics table are guaranteed. Other parametric values quoted in this data sheet are provided for guidance.

X-ON Electronics

Largest Supplier of Electrical and Electronic Components

Click to view similar products for [Board Mount Temperature Sensors](#) category:

Click to view products by [Maxim](#) manufacturer:

Other Similar products are found below :

[5962-8757102XA](#) [66F115](#) [EMC1063-1-ACZL-TR](#) [NCT218FCT2G](#) [O53GAB175A-160Y](#) [3610085020002](#) [389049M9527](#) [MIKROE-912](#)
[ADM1023ARQZ-REEL](#) [ADM1032ARMZ-1RL](#) [AT30TS74-U1FMBB-T](#) [AT30TS74-U1FMAB-T](#) [AT30TS74-U1FMCB-T](#) [AT30TS74-](#)
[U1FMDB-T](#) [ADT7483AARQZ-RL](#) [ADT7481ARMZ-REEL](#) [ADT7463ARQZ-REEL](#) [MCP98243T-BE/MC](#) [66L080-0226](#) [5962-8757103XA](#)
[S-58LM20A-I4T1U](#) [NCT375MNR2G](#) [LM84CIMQA](#) [CAT34TS00VP2GT4A](#) [NCT80DBR2G](#) [SEN-16304](#) [GX21M15](#) [GX122](#) [NST175H-](#)
[QSPR](#) [TC6501P065VCTTR](#) [AT-1U](#) [MCP9700AT-E/LT](#) [MCP9701-E/TO](#) [MCP9803-M/MS](#) [MCP9701A-E/TO](#) [LM57FEPWQ1](#) [LM57FPW](#)
[LM57FSPWQ1](#) [60-41123102-0150.0010](#) [60-43123102-0150.0010](#) [60-53123102-0150.0010](#) [MLX90615SSG-DAA-000-TU](#) [TMP303CDRLR](#)
[TC6501P055VCTTR](#) [TC6503P005VCTTR](#) [ADT7311WTRZ-RL](#) [ADT7311WTRZ-RL7](#) [ADT7473ARQZ-REEL](#) [LM335AM](#)
[LM335AM/NOPB](#)