



# Fan Controller/Driver with Factory-Programmed Temperature Thresholds

MAX6665

## General Description

The MAX6665 is a fully integrated thermal switch with an internal power transistor for driving a cooling fan rated up to 24V and 250mA. When the MAX6665's temperature rises above a factory-programmed threshold, the FANOUT pin becomes active and powers the fan.

The MAX6665 is available with factory-programmed fan activation threshold temperatures from +40°C to +70°C in 5°C increments. Accuracy of the fan activation trip point is  $\pm 1^\circ\text{C}$  (typ) and  $\pm 3^\circ\text{C}$  (max). The trip point's hysteresis is pin selectable to 1°C, 4°C, or 8°C. Two open-drain logic outputs indicate overtemperature conditions: WARN is activated when the temperature is 15°C above the fan activation threshold, and OT is activated when the temperature is 30°C above the threshold. These features can be used to safely power down systems that are overheated.

The MAX6665 operates from a +2.7V to +5.5V power supply, and the associated fan can be powered from 4.5V to 24V. It is available in an 8-pin SO package and operates from -40°C to +125°C.

## Applications

Notebook and Desktop Computers  
Servers  
PC Power Supplies  
Laboratory Instruments  
Card Racks

## Typical Operating Circuit

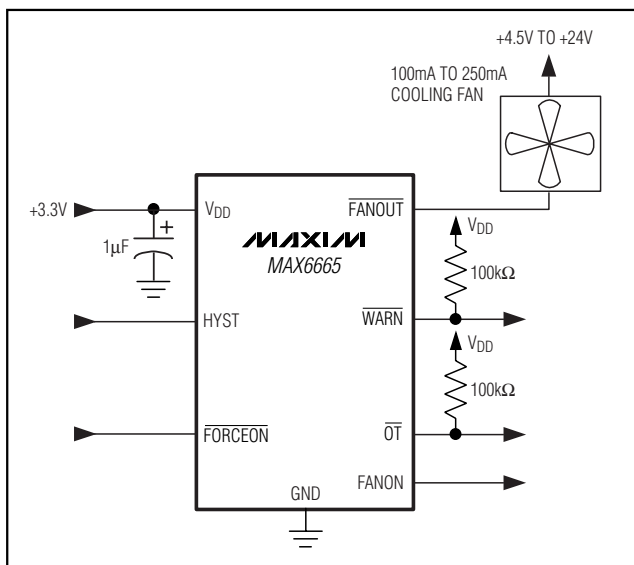

## Features

- ◆ On-Chip 250mA Fan Switch
- ◆ No External Components Required
- ◆ Factory-Programmed Thresholds
- ◆ Two Overtemperature Warning Signals
- ◆ Pin-Selectable 1°C, 4°C, and 8°C Hysteresis
- ◆ Low 65µA Supply Current

## Ordering Information

PART	TEMP. RANGE	PIN-PACKAGE	THRESHOLD
MAX6665ASA40	-40°C to +125°C	8 SO-EP*	40°C
MAX6665ASA45	-40°C to +125°C	8 SO-EP*	45°C
MAX6665ASA50	-40°C to +125°C	8 SO-EP*	50°C
MAX6665ASA55	-40°C to +125°C	8 SO-EP*	55°C
MAX6665ASA60	-40°C to +125°C	8 SO-EP*	60°C
MAX6665ASA65	-40°C to +125°C	8 SO-EP*	65°C
MAX6665ASA70	-40°C to +125°C	8 SO-EP*	70°C

\*Exposed paddle

## Pin Configuration

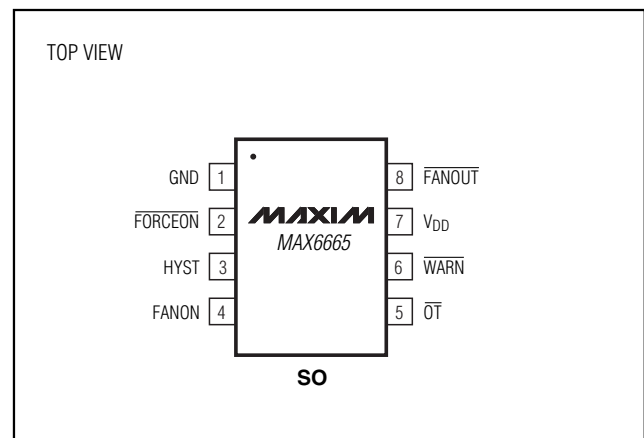

**MAXIM**

Maxim Integrated Products 1

**For pricing, delivery, and ordering information, please contact Maxim/Dallas Direct! at 1-888-629-4642, or visit Maxim's website at [www.maxim-ic.com](http://www.maxim-ic.com).**

# Fan Controller/Driver with Factory-Programmed Temperature Thresholds

## ABSOLUTE MAXIMUM RATINGS

V <sub>DD</sub> to GND .....	-0.3V to +6V
FANOUT to GND .....	-0.3V to +28V
FORCEON, HYST, FANON to GND .....	-0.3V to (V <sub>DD</sub> + 0.3V)
WARN, OT to GND .....	-0.3V to +6V
FANOUT Continuous Current.....	400mA
All Other Pins .....	±20mA

Continuous Power Dissipation (T <sub>A</sub> = +70°C)	
8-Pin SO (derate 19.6mW/°C above +70°C).....	1568mW
Operating Temperature Range .....	-40°C to +125°C
Junction (storage) Temperature Range .....	-65°C to +150°C
Lead Temperature (soldering, 10s) .....	+300°C

Stresses beyond those listed under "Absolute Maximum Ratings" may cause permanent damage to the device. These are stress ratings only, and functional operation of the device at these or any other conditions beyond those indicated in the operational sections of the specifications is not implied. Exposure to absolute maximum rating conditions for extended periods may affect device reliability.

## ELECTRICAL CHARACTERISTICS

(V<sub>DD</sub> = +2.7V to +5.5V, T<sub>A</sub> = -40°C to +125°C. Typical values are at V<sub>DD</sub> = +3.3V and T<sub>A</sub> = +25°C, unless otherwise noted.) (Note 1)

PARAMETER	CONDITIONS	MIN	TYP	MAX	UNITS
Supply Voltage	V <sub>DD</sub> pin	2.7		5.5	V
Supply Current	No load		65	200	μA
FANOUT Drive Voltage	FANOUT pin			26	V
FANOUT Output Current Capability	V <sub>FANOUT</sub> < 0.8V	250			mA
	V <sub>FANOUT</sub> < 0.6V, T <sub>A</sub> ≤ T <sub>TH</sub> + 10°C, V <sub>CC</sub> ≥ +3.3V	250			
FANOUT Leakage Current	V <sub>FANOUT</sub> = 26V, T <sub>A</sub> = +60°C		3		μA
FANOUT Threshold, T <sub>TH</sub>	MAX6665ASA40		40		°C
	MAX6665ASA45		45		
	MAX6665ASA50		50		
	MAX6665ASA55		55		
	MAX6665ASA60		60		
	MAX6665ASA65		65		
	MAX6665ASA70		70		
FANOUT Threshold Error		-3	±1	+3	°C
FANOUT Hysteresis	HYST is unconnected		1		°C
	HYST ≤ 0.3V <sub>DD</sub>		4		
	HYST ≥ 0.7V <sub>DD</sub>		8		
WARN Threshold	Relative to FANOUT temperature threshold		+15		°C
OT Threshold	Relative to FANOUT temperature threshold		+30		°C
WARN and OT Hysteresis			2		°C
FANON Output High Voltage	I <sub>FANON</sub> = 0.5mA source	2.0			V
FANON Output Low Voltage	I <sub>FANON</sub> = 0.5mA sink			0.7	V
WARN and OT Output Voltage Low	I <sub>WARN</sub> = 1.2mA or I <sub>OT</sub> = 1.2mA sink			0.3	V
	I <sub>WARN</sub> = 20mA or I <sub>OT</sub> = 20mA sink		0.5		
Open-Drain Leakage Current	V <sub>WARN</sub> = 5.5V or V <sub>OT</sub> = 5.5V		0.1		μA
Input Low Voltage	FORCEON and HYST pins			0.3V <sub>DD</sub>	V
Input High Voltage	FORCEON and HYST pins	0.7V <sub>DD</sub>			V
Input Current	FORCEON connected to V <sub>DD</sub> or GND	-1		+1	μA
	HYST connected to V <sub>DD</sub> or GND	-15		+15	

**Note 1:** Specifications over temperature are guaranteed by design. Parts are 100% production tested at 10°C below the temperature threshold.

# Fan Controller/Driver with Factory-Programmed Temperature Thresholds

## Typical Operating Characteristics

( $V_{DD} = +3.3V$ , unless otherwise noted.)

MAX6665

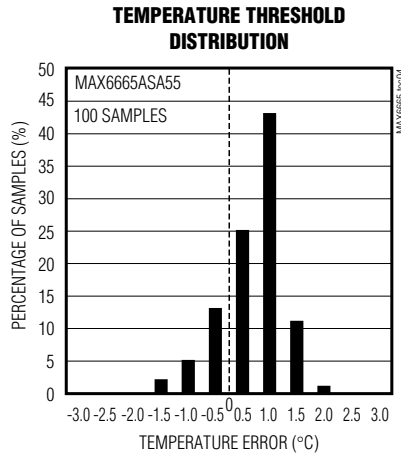
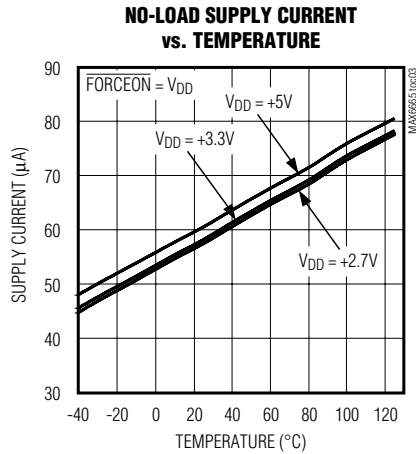
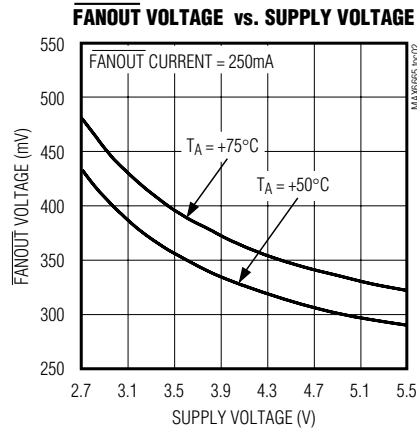
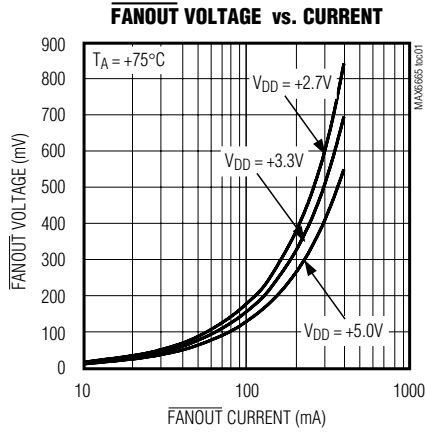

# Fan Controller/Driver with Factory-Programmed Temperature Thresholds

## Pin Description

PIN	NAME	FUNCTION
1	GND	Ground
2	$\overline{\text{FORCEON}}$	Force Fan On Input. Set $\overline{\text{FORCEON}}$ low to force the fan switch on. Set $\overline{\text{FORCEON}}$ high for normal operation.
3	HYST	Three-State Hysteresis Input. Connect HYST to $V_{DD}$ for 8°C, GND for 4°C, and leave HYST unconnected for 1°C hysteresis.
4	FANON	Fan-On Indicator Output. Push-pull output. FANON is high when the fan switch is on. FANON is low when the fan switch is off.
5	$\overline{\text{OT}}$	Overtemperature Output. Active-low when the temperature is 30°C above the fan threshold. Open-drain output, requires resistive pullup.
6	$\overline{\text{WARN}}$	Overtemperature Warning Output. Active-low when the temperature is 15°C above the fan threshold. Open-drain output, requires resistive pullup.
7	$V_{DD}$	Supply Voltage. Bypass with a 1 $\mu$ F capacitor to GND as close to $V_{DD}$ pin as possible.
8	$\overline{\text{FANOUT}}$	Fan-Switch (Driver) Output. Connect to the low side of a fan.
Exposed Paddle	GND	Ground

## Detailed Description

The MAX6665 is a simple fan controller/driver that turns on the internal power transistor when its die temperature exceeds a factory-set threshold. By connecting a small (typically 5V to 12V, 100mA to 250mA) cooling fan to  $\overline{\text{FANOUT}}$ , a simple on/off fan-control system is created.  $\overline{\text{FANOUT}}$  drives the fan's low side. The fan's positive supply pin should be connected to its normal power-supply voltage (up to 24V nominal).

To turn the fan on when the MAX6665's die temperature is less than the threshold voltage, drive  $\overline{\text{FORCEON}}$  low. This overrides the internal control circuitry and allows an external device to activate the fan. FANON is an active-high push-pull logic output that goes high when the fan is turned on, either when temperature exceeds the threshold or the fan is forced on.

$\overline{\text{WARN}}$  is an active-low, open-drain digital output that indicates the MAX6665's die temperature exceeds 15°C above the fan trip threshold.  $\overline{\text{WARN}}$  output serves as a warning that the system temperature has continued to rise well above the fan activation temperature.  $\overline{\text{OT}}$  is an active-low open-drain digital output that indicates the MAX6665's die temperature exceeds 30°C above the fan trip threshold. It serves as a thermal shutdown output to the system in case of excessive temperature rise. Figure 1 shows a typical application circuit for a high-reliability, fail-safe temperature monitor.

## Applications Information

### Thermal Considerations and Hysteresis

The temperature comparator has hysteresis to prevent small temperature changes near the threshold temperature from causing the fan to turn on and off repeatedly over short periods of time. The  $\overline{\text{FANOUT}}$  pin goes active and powers the fan when the MAX6665's die temperature exceeds the factory-programmed trip temperature. As the cooling fan operates, the circuit board temperature should decrease, which in turn causes the MAX6665's die temperature to decrease. When the die temperature is equal to the trip threshold minus the hysteresis, the  $\overline{\text{FANOUT}}$  pin turns the fan off, removing power from the fan. The HYST pin sets the amount of hysteresis to 1°C, 4°C, or 8°C by letting the pin float or connecting to GND or  $V_{DD}$ , respectively. This allows the amount of hysteresis to be matched to the cooling and noise requirements of the system.

Hysteresis is also affected by self-heating of the MAX6665's die. The fan current flowing through the on-chip power transistor causes the die temperature to increase. For example, assume the MAX6665 controls a 125mA fan. When the fan is operating, the voltage drop across the output transistor is typically under 250mV. At 250mV, the power dissipation is 31.25mW. The thermal resistance of the MAX6665 package (with EP soldered) is 51°C/W, so the die temperature

# Fan Controller/Driver with Factory-Programmed Temperature Thresholds

MAX6665

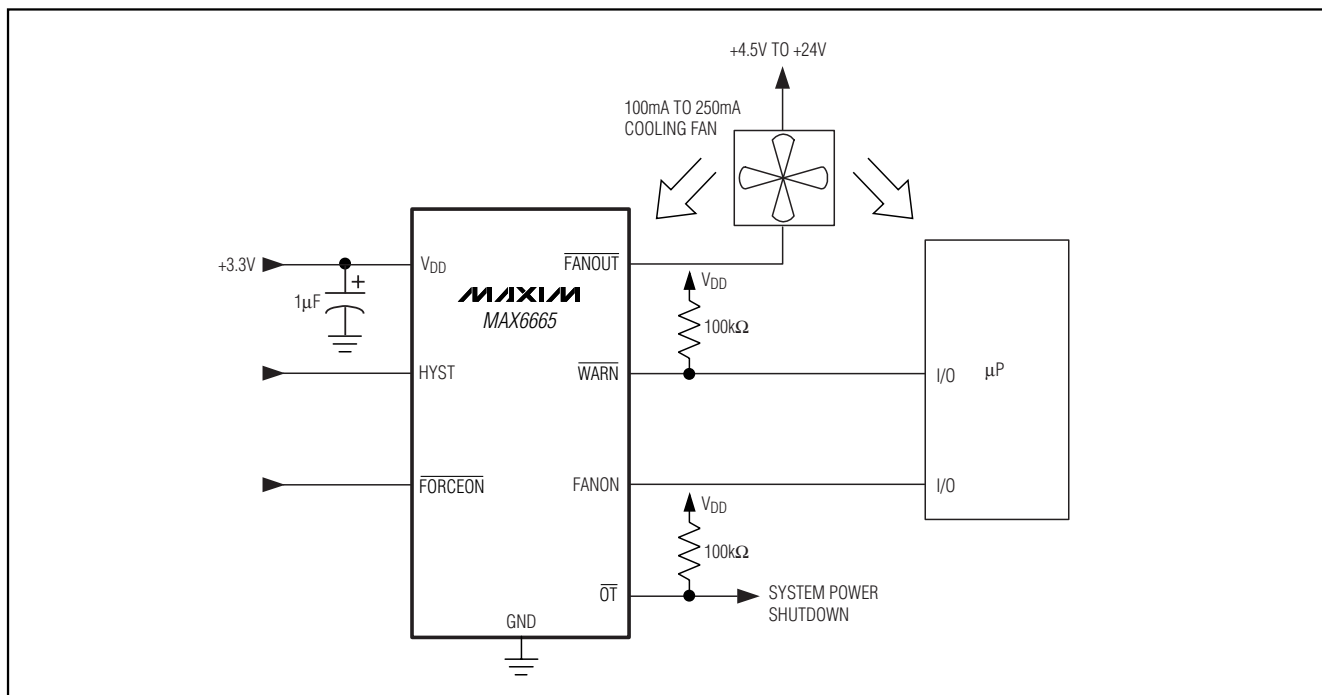

Figure 1. High-Reliability, Fail-Safe Fan Controller and Temperature Monitor

increases by a maximum of:

$$51^{\circ}\text{C}/\text{W} \times 0.03125\text{W} = 1.59^{\circ}\text{C}$$

Therefore, the effective hysteresis is about 1.59°C higher than the hysteresis selected by the HYST pin. For example, setting the HYST pin for 8°C of hysteresis results in an effective hysteresis of about 9.6°C.

A larger fan with a power-supply current of 250mA causes a maximum voltage drop of 0.6V at the output pin. This results in 150mW power dissipation and the die temperature increases by:

$$51^{\circ}\text{C}/\text{W} \times 0.150\text{W} = 7.65^{\circ}\text{C}$$

If the HYST pin has been set for 8°C of hysteresis, the total effective hysteresis will be about 15.7°C.

Using fans with somewhat higher operating current than 250mA results in higher voltage across the output transistor. The increased power dissipation caused by the higher current and voltage levels will increase self-heating, thereby increasing the effective hysteresis. When using higher-power fans, be sure that the MAX6665's power dissipation does not cause so much self-heating that the MAX6665 stays on constantly.

## Locating the MAX6665

The location of the MAX6665 in the system affects its operation. Because the fan is turned on and off based on the MAX6665's die temperature, place the MAX6665 close to major heat-generating components in the system—a high-speed CPU or a power device, for example. A higher supply voltage reduces the FANOUT voltage, which reduces the self-heating effects.

The die temperature of the MAX6665 tracks the temperature of its leads and the EP. If it is soldered to a PC board, it quickly reaches the temperature of the traces in that section of the circuit board. Air temperature affects the die temperature. Since the plastic package does not conduct heat as well as the leads, the effect of air temperature is much less than that of lead temperature.

## Layout Issues

The MAX6665's GND pin is ground return for the fan driver and the device. Large fan current induces noise (ground bounce) to the MAX6665. Bypass VDD to GND with a 1µF tantalum capacitor located as close to the MAX6665 as possible. For long VDD and GND lines, an additional bypass capacitor may be needed. The bypass capacitor reduces GND noise. The EP is internally connected to the GND pin. Solder the EP to the ground plane for better electrical and thermal performance.

# Fan Controller/Driver with Factory-Programmed Temperature Thresholds

## Chip Information

TRANSISTOR COUNT: 1543 MOS  
 119 BIPOLAR  
 PROCESS: BiCMOS

## Package Information

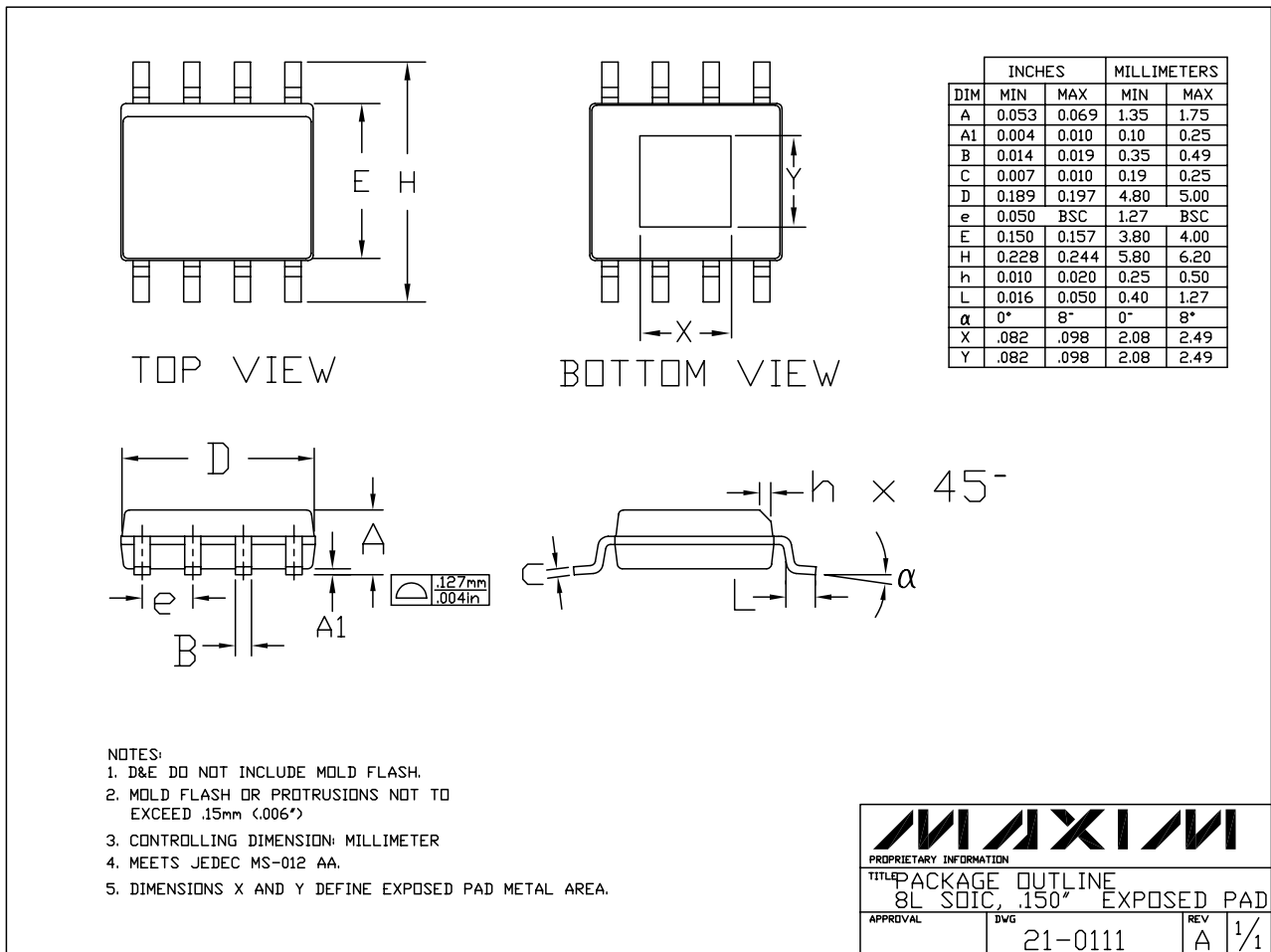

Maxim cannot assume responsibility for use of any circuitry other than circuitry entirely embodied in a Maxim product. No circuit patent licenses are implied. Maxim reserves the right to change the circuitry and specifications without notice at any time.

6 Maxim Integrated Products, 120 San Gabriel Drive, Sunnyvale, CA 94086 408-737-7600

## X-ON Electronics

Largest Supplier of Electrical and Electronic Components

*Click to view similar products for [Motor/Motion/Ignition Controllers & Drivers](#) category:*

*Click to view products by [Maxim](#) manufacturer:*

Other Similar products are found below :

[FSB50550TB2](#) [FSBF15CH60BTH](#) [MSVCPM2-63-12](#) [MSVGW45-14-2](#) [MSVGW54-14-3](#) [MSVGW54-14-5](#) [NTE7043](#) [LA6565VR-TLM-E](#)  
[LB11650-E](#) [LB1837M-TLM-E](#) [LB1845DAZ-XE](#) [LC898300XA-MH](#) [SS30-TE-L-E](#) [26700](#) [LV8281VR-TLM-H](#) [BA5839FP-E2](#) [IRAM236-1067A](#) [LA6584JA-AH](#) [LB11847L-E](#) [NCV70501DW002R2G](#) [AH293-PL-B](#) [STK672-630CN-E](#) [TND315S-TL-2H](#) [FNA23060](#) [FSB50250AB](#)  
[FNA41060](#) [MSVB54](#) [MSVBTC50E](#) [MSVCPM3-54-12](#) [MSVCPM3-63-12](#) [MSVCPM4-63-12](#) [MSVTA120](#) [FSB50550AB](#)  
[NCV70501DW002G](#) [LC898301XA-MH](#) [LV8413GP-TE-L-E](#) [MSVGW45-14-3](#) [MSVGW45-14-4](#) [MSVGW45-14-5](#) [MSVGW54-14-4](#)  
[STK984-091A-E](#) [SLA7026M](#) [MP6519GQ-Z](#) [LB11651-E](#) [IRSM515-025DA4](#) [LV8127T-TLM-H](#) [NCP81382MNTXG](#) [TDA21801](#)  
[LB11851FA-BH](#) [NCV70627DQ001R2G](#)