



Fan-Failure Detector with Integrated Power Switch

MAX6684

General Description

The MAX6684 is an integrated fan-failure detector that detects when a fan exhibits excessive underspeed or a locked rotor. This device is especially well suited for critical systems where no fan control, or simple on/off control is desired. The MAX6684 detects fan failure by evaluating fluctuations in current at the low side of the fan; no tachometer signal is necessary. The output of the device, $\overline{\text{FAIL}}$, is an active-low, open-drain alarm. The MAX6684 can also be used to switch the fan on or off, based on the state of a logic-level input, $\overline{\text{OFF}}$. This device can be used with fans rated at up to 24V and 250mA. The MAX6684 is available in an 8-pin SO package, and is specified for operation from -40°C to $+85^{\circ}\text{C}$.

Features

- ◆ Dedicated Fan-Failure Detector
- ◆ Works with Ordinary 2-Wire Fans
- ◆ No Fan Tachometer Output Required
- ◆ No Software Development Required
- ◆ No Analog Circuit Design Required
- ◆ Logic-Level Fan Driver Control
- ◆ Works with Fans Rated Up to 24V/250mA

Applications

Desktop PCs
Notebooks
Networking Equipment
Telecommunications
Industrial Applications

Ordering Information

PART	TEMP RANGE	PIN-PACKAGE
MAX6684ESA	-40°C to $+85^{\circ}\text{C}$	8 SO

Typical Operating Circuit

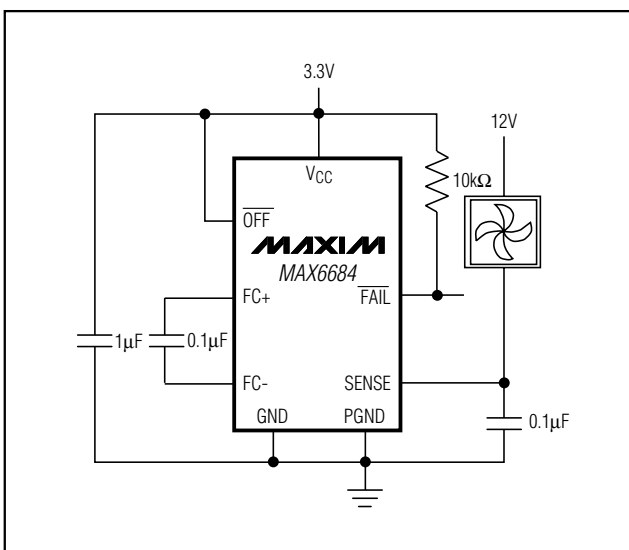

Pin Configuration

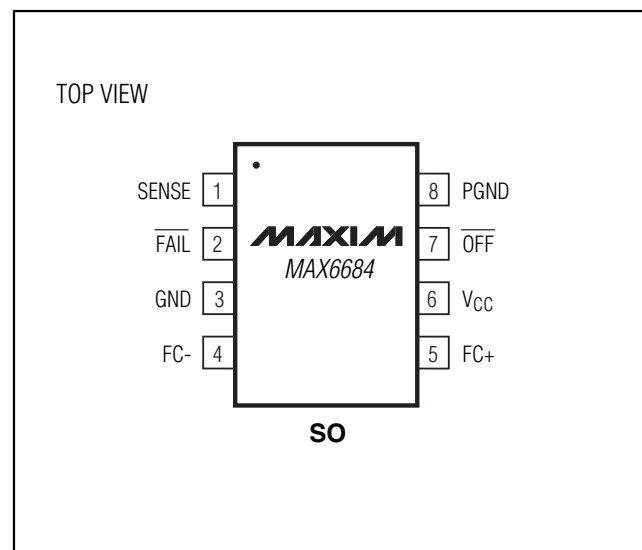

Fan-Failure Detector with Integrated Power Switch

ABSOLUTE MAXIMUM RATINGS

Voltages Referenced to GND, Unless Otherwise Noted

V _{CC}	-0.3V to +6.0V
FC+, FC-	-0.3V to (V _{CC} + 0.3V)
$\overline{\text{OFF}}$, FAIL	-0.3V to +6.0V
PGND	-0.3V to +0.3V
SENSE to PGND	-0.3V to +28.0V
SENSE Current	1400mA

Continuous Power Dissipation (T_A = +70°C)

8-Pin SO (derate 5.9mW/°C above +70°C)	470mW
Operating Temperature Range	-40°C to +85°C
Storage Temperature Range	-65°C to +150°C
Junction Temperature	+150°C
Soldering Temperature (vapor phase, 60s)	+215°C
Soldering Temperature (infrared, 15s)	+220°C

Stresses beyond those listed under "Absolute Maximum Ratings" may cause permanent damage to the device. These are stress ratings only, and functional operation of the device at these or any other conditions beyond those indicated in the operational sections of the specifications is not implied. Exposure to absolute maximum rating conditions for extended periods may affect device reliability.

ELECTRICAL CHARACTERISTICS

(V_{CC} = 3.0 to 5.5V, $\overline{\text{OFF}}$ = V_{CC}, T_A = -40°C to +85°C, unless otherwise noted. Typical values are at V_{CC} = 3.3V, T_A = +25°C.) (Note 1)

PARAMETER	SYMBOL	CONDITIONS	MIN	TYP	MAX	UNITS
Supply Voltage	V _{CC}		3.0		5.5	V
Supply Current	I _{CC}	I _{FAN} = 300mA			3.4	mA
V _{CC} Shutdown Supply Current	I _{SHDN}	$\overline{\text{OFF}}$ = GND			10	μA
SENSE-to-PGND Output Low Voltage		I _{FAN} = 300mA		0.3	0.66	V
SENSE-to-PGND Output On-Resistance	R _{DS(on)}			1	2.2	Ω
SENSE Leakage Current		V _{SENSE} = 26V		1	10	μA
V _{FAIL} Output Low Voltage		I _{FAIL} = 3mA			0.8	V
V _{FAIL} Output Leakage Current		V _{FAIL} = 5.5V		0.1	1	μA
Average SENSE (Fan) Current			50		300	mA
SENSE Current Shutdown		V _{CC} = 3V	600		1200	mA
Thermal Shutdown of SENSE		15°C hysteresis		160		°C
Fan-Current Fluctuation Frequency		No fault detected	25		400	Hz
V _{FAIL} Output Delay After Fault	t _{FD}		0.3	1	2.0	s
Minimum Fan-Current Fluctuation Level (Note 2)		No fault detected	15	35	60	mAp-p
$\overline{\text{OFF}}$ Input High Voltage	V _{IH}		0.7 x V _{CC}			V
$\overline{\text{OFF}}$ Input Low Voltage	V _{IL}				0.3 x V _{CC}	V
$\overline{\text{OFF}}$ Input Current			-10	0	1	μA

Note 1: Specifications to -40°C are guaranteed by design and not production tested.

Note 2: The MAX6684 is guaranteed to register a fault when the fan current fluctuates less than the minimum; it is guaranteed not to register a fault when the fan current is above the maximum.

Fan-Failure Detector with Integrated Power Switch

Typical Operating Characteristics

($V_{CC} = 3.3V$, $T_A = +25^\circ C$, unless otherwise noted.)

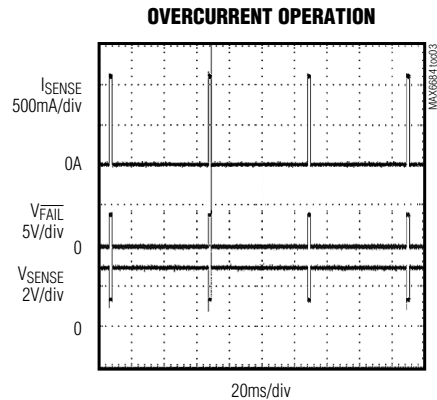
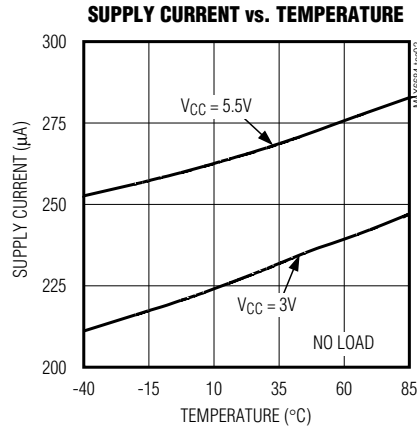
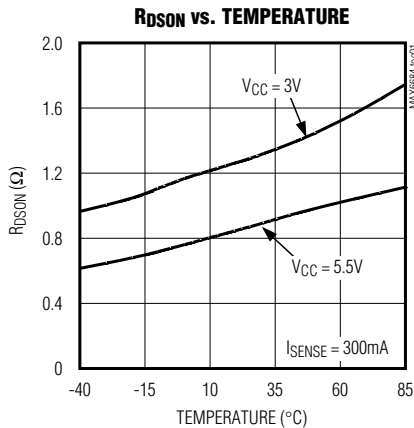

MAX6684

Pin Description

PIN	NAME	FUNCTION
1	SENSE	Positive Current-Sensing Terminal. Connect SENSE to low side of fan.
2	FAIL	Active-Low, Open-Drain Fan-Failure Output
3	GND	Ground
4	FC-	Connect to 0.1 μF capacitor for most locked-rotor detection applications. To detect minimum speed, select C_F according to <i>Minimum Speed and Locked-Rotor Detection</i> .
5	FC+	Connect to 0.1 μF capacitor for most locked-rotor detection applications. To detect minimum speed, select C_F according to <i>Minimum Speed and Locked-Rotor Detection</i> .
6	V_{CC}	Supply Voltage Input. Bypass V_{CC} to GND with a 1 μF capacitor.
7	\overline{OFF}	Active-Low Fan-Control Input. Drive \overline{OFF} high or leave floating to turn fan on. Drive \overline{OFF} low to turn fan off.
8	PGND	Power Ground. Connect to GND.

Fan-Failure Detector with Integrated Power Switch

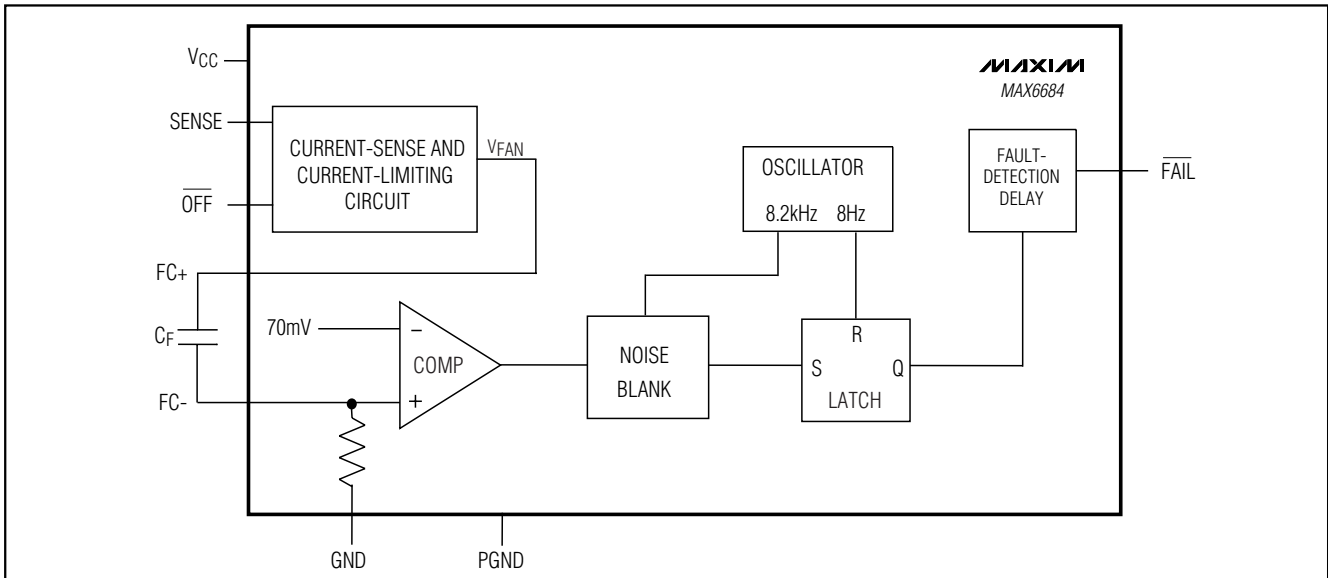

Figure 1. MAX6684 Functional Diagram

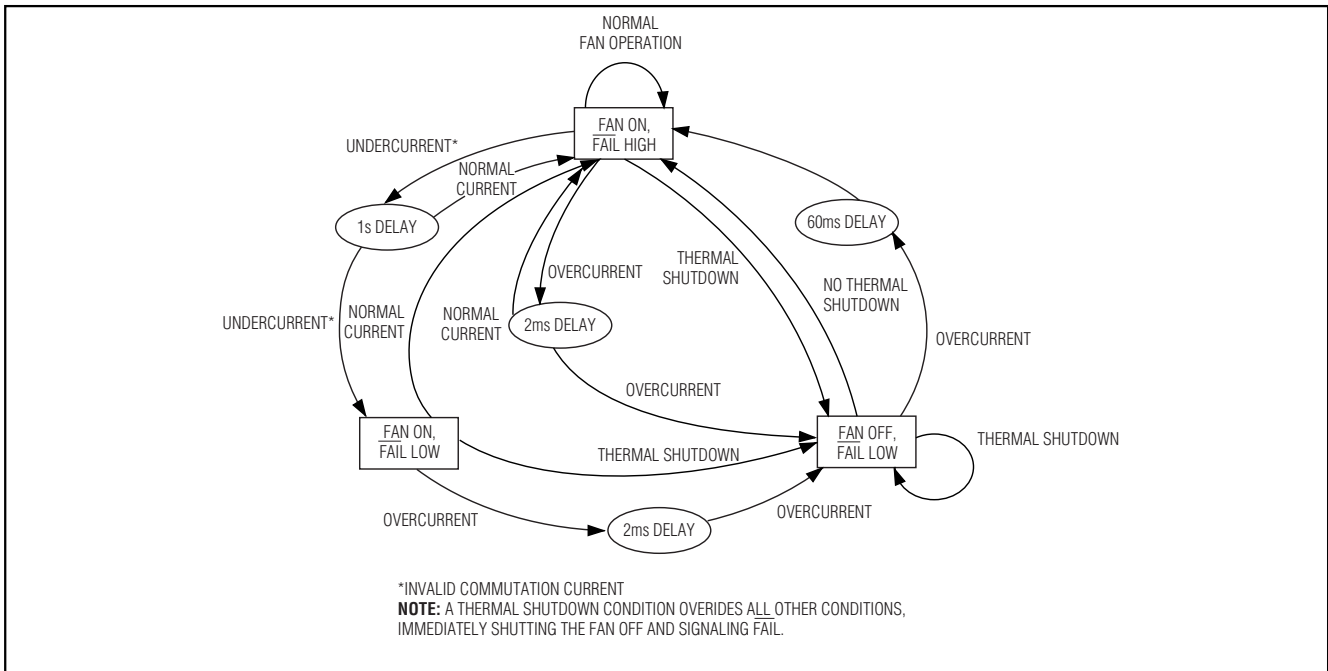

Figure 2. MAX6684 State Diagram

Detailed Description

The MAX6684 detects fan failure in brushless DC fans. This device is especially well suited for critical systems where no fan control is desired. No software is necessary to control the MAX6684.

Fan-Failure Detection

Fan failure is determined based on the fan current observed at SENSE. The current observed at SENSE is converted to a voltage, VFAN, and highpass filtered by the capacitor, CF, from FC+ to FC- (Figure 1).

Fan-Failure Detector with Integrated Power Switch

MAX6684

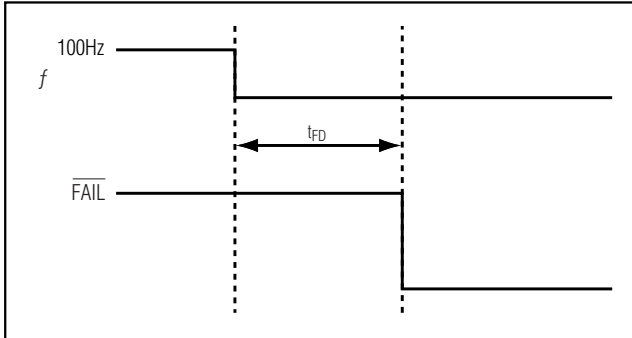

Figure 3. MAX6684 Commutation Fault Timing Diagram

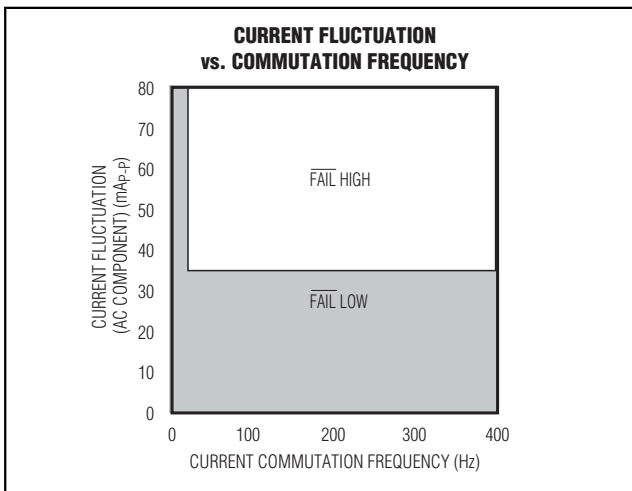

Figure 4. Current Fluctuation and Commutation Frequency Diagram

Undercurrent (AC Component)

Fan failure is signaled if the AC component of I_{FAN} is less than 35mA_{p-p} and remains out of specification for at least 1s (Figure 2). The fan remains powered during undercurrent failures.

Minimum Speed and Locked-Rotor Detection

The MAX6684 asserts \overline{FAIL} if the fan-current fluctuation frequency is below 25Hz, which corresponds to a fan speed of approximately 700rpm. The fan remains powered during a locked rotor or an under-speed failure condition (Figures 3 and 4).

The MAX6684 can be designed to detect fan failure below intended speeds by varying the value of C_F . Because of the complexity of fan-current waveforms, the value of C_F has to be arrived at empirically and must be verified by bench testing. The guidelines of

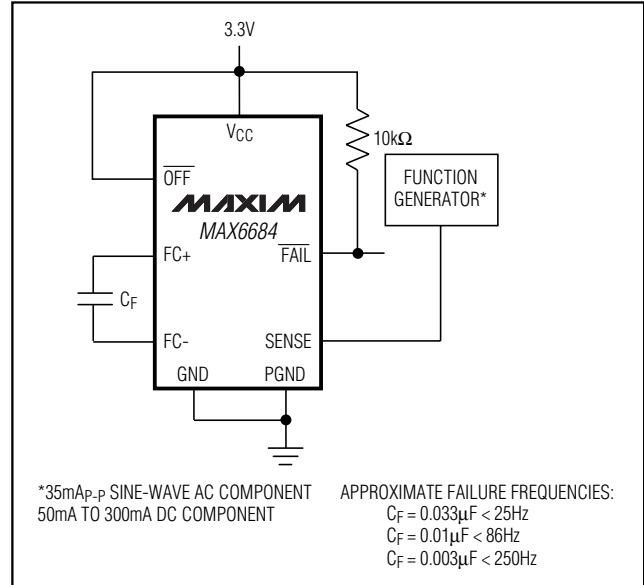

Figure 5. Test Circuit Demonstrates Failure Frequency as a Function of the Value of C_F

Figure 5 are only appropriate for the test signals used and do not represent all possible fan waveforms. They are to illustrate the ability of the MAX6684 to discriminate failure due to low fan speed. As a rule, failure typically occurs when the amplitude measured at pin 4 of the MAX6684 drops below 70mV.

Overcurrent Protection

If an overcurrent condition begins and continues for 2ms, fan failure is signaled for 60ms. During this 60ms period, the power to the fan is turned off. If the part does not enter thermal shutdown and the overcurrent condition continues, power to the fan is turned on every 62ms for 2ms (see Overcurrent Operation in *Typical Operating Characteristics*). Once the overcurrent condition is removed, the fan is powered continuously. A 0.1 μF capacitor between SENSE and PGND prevents the internal DMOS switch from being damaged by back EMF current.

Thermal Shutdown

A die temperature in excess of +160°C initiates thermal shutdown. In thermal shutdown, the MAX6684 shuts off the fan and the \overline{FAIL} output asserts. While in thermal shutdown, the MAX6684 monitors the die temperature. Once the die has cooled to below +145°C, the MAX6684 exits thermal shutdown and power is returned to the fan. A thermal shutdown fault condition has precedence over all other failure modes. While the MAX6684 die is over temperature, power is not cycled to the fan, as occurs during overcurrent failure.

Fan-Failure Detector with Integrated Power Switch

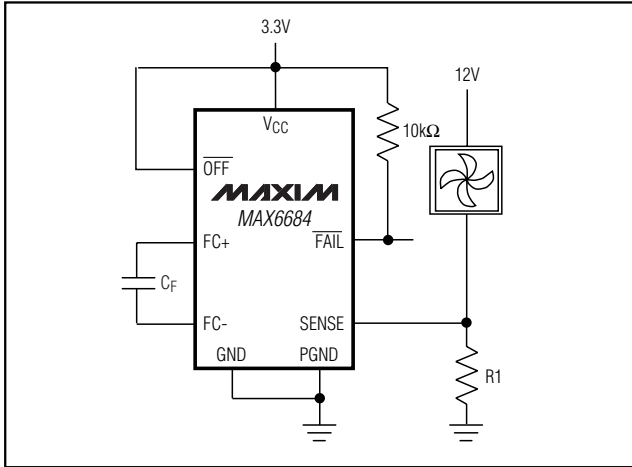

Figure 6. Increased Current Capability Using External Resistance

FAIL Output

The $\overline{\text{FAIL}}$ output is an active-low, open-drain alarm. Three fan-failure modes are possible (see the *Fan-Failure Detection* section).

OFF

Drive $\overline{\text{OFF}}$ low to turn off power to the fan. If $\overline{\text{OFF}}$ is tied high or floating, the MAX6684 is enabled.

Applications Information

Fan Compatibility

This device can be used with fans that require operating voltages up to 24V and supply currents up to 250mA. See the *Fan-Failure Detection* section regarding fan-current waveform issues.

Figures 6 and 7 show two ways to increase the current capability of the MAX6684. In Figure 6, a parallel external resistance between SENSE and PGND is used to increase current capability. This method eliminates the fan-control functionality normally associated with the MAX6684 $\overline{\text{OFF}}$ pin. Select the external resistor, R1, such that approximately 100mA flows across the internal $R_{\text{DS(on)}}$ of the MAX6684, which is typically 1Ω.

Figure 7 also shows how to use an external current-boost PNP bipolar transistor to increase the current capability of the MAX6684. This method preserves the fan-control functionality of the $\overline{\text{OFF}}$ pin. A 6Ω R_{BOOST} allows approximately 100mA of the fan current to flow through the MAX6684.

The MAX6684 is not compatible with fans designed for use with external PWM fan controllers.

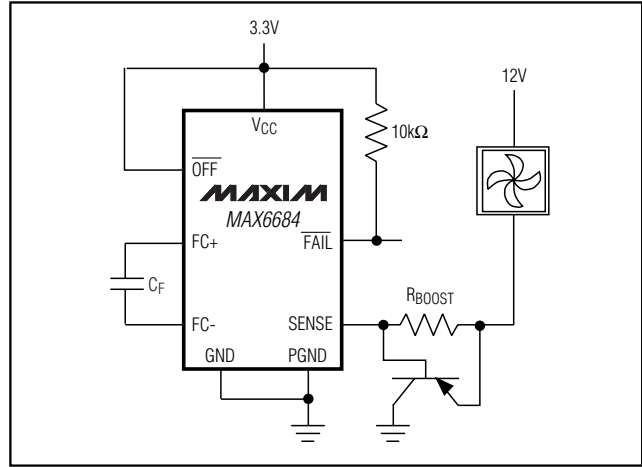

Figure 7. Increased Current Capability Using PNP Transistor

Fan-Specific Concerns

Because fan-current waveforms can vary substantially from one given fan make or model to another, validate the performance of the MAX6684 with the intended fan. It is possible to encounter fans where the MAX6684 is limited to detecting locked-rotor conditions only, because of the nature of the fan-current waveform. In cases where fan-speed detection does not seem to be working properly (although locked-rotor detection is taking place), adding a 100μF capacitor across the fan may solve the problem.

When the MAX6684 is used with fans that include locked-rotor protection, the $\overline{\text{FAIL}}$ output is active when the rotor locks, and toggles each time the locked-rotor protection built into the fan attempts a restart, over a timeframe typically measured in seconds. Toggling should be considered an indication of fan failure; conversely, a fan is functioning properly only when $\overline{\text{FAIL}}$ is constantly inactive.

Capacitor Selection

A ceramic or mylar capacitor, C_F , is required from FC- to FC+. The capacitor blocks the DC component of the signal, allowing the MAX6684 to monitor the AC current consumption of the fan. See the *Minimum Speed and Locked-Rotor Detection* section for more information.

Power Supply and Bypassing

The effects of noise can be minimized by placing a 1μF ceramic bypass capacitor close to the device's supply pin.

Fan-Failure Detector with Integrated Power Switch

Chip Information

TRANSISTOR COUNT: 3993

PROCESS: BiCMOS

Package Information

MAX6684

9LUCSP, 3x3.EPS

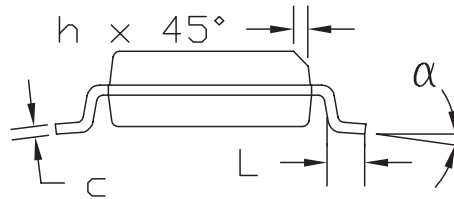
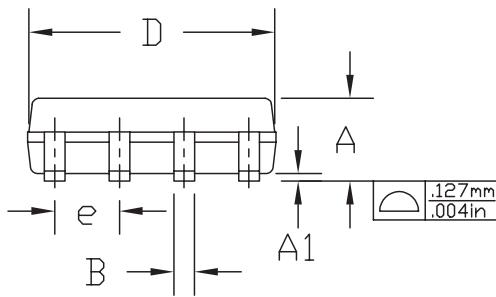
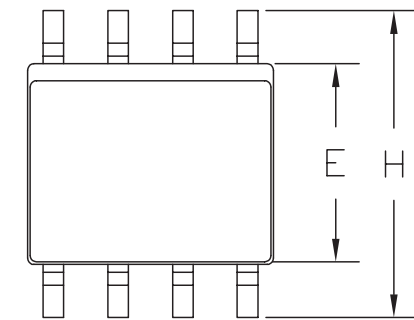

DIM	INCHES		MILLIMETERS	
	MIN	MAX	MIN	MAX
A	0.053	0.069	1.35	1.75
A1	0.004	0.010	0.10	0.25
B	0.014	0.019	0.35	0.49
C	0.007	0.010	0.19	0.25
D	0.189	0.197	4.80	5.00
e	0.050	BSC	1.27	BSC
E	0.150	0.157	3.80	4.00
H	0.228	0.244	5.80	6.20
h	0.010	0.020	0.25	0.50
L	0.016	0.050	0.40	1.27
α	0?	8?	0?	8?

NOTES:

1. D&E DO NOT INCLUDE MOLD FLASH.
2. MOLD FLASH OR PROTRUSIONS NOT TO EXCEED .15mm (.006")
3. CONTROLLING DIMENSION: MILLIMETER
4. MEETS JEDEC MS-012 AA.

MAXIM			
<small>PROPRIETARY INFORMATION</small>			
TITLE 8L SOIC OUTLINE			
<small>APPROVAL</small>	<small>DWG</small> 21-0325	<small>REV</small> A	<small>1/1</small>

Maxim cannot assume responsibility for use of any circuitry other than circuitry entirely embodied in a Maxim product. No circuit patent licenses are implied. Maxim reserves the right to change the circuitry and specifications without notice at any time.

Maxim Integrated Products, 120 San Gabriel Drive, Sunnyvale, CA 94086 408-737-7600 _____ **7**

X-ON Electronics

Largest Supplier of Electrical and Electronic Components

Click to view similar products for [Motor/Motion/Ignition Controllers & Drivers](#) category:

Click to view products by [Maxim](#) manufacturer:

Other Similar products are found below :

[FSB50550TB2](#) [FSBF15CH60BTH](#) [MSVCPM2-63-12](#) [MSVGW45-14-2](#) [MSVGW54-14-3](#) [MSVGW54-14-5](#) [NTE7043](#) [LA6565VR-TLM-E](#)
[LB11650-E](#) [LB1837M-TLM-E](#) [LB1845DAZ-XE](#) [LC898300XA-MH](#) [SS30-TE-L-E](#) [26700](#) [LV8281VR-TLM-H](#) [BA5839FP-E2](#) [IRAM236-1067A](#) [LA6584JA-AH](#) [LB11847L-E](#) [NCV70501DW002R2G](#) [AH293-PL-B](#) [STK672-630CN-E](#) [TND315S-TL-2H](#) [FNA23060](#) [FSB50250AB](#)
[FNA41060](#) [MSVB54](#) [MSVBTC50E](#) [MSVCPM3-54-12](#) [MSVCPM3-63-12](#) [MSVCPM4-63-12](#) [MSVTA120](#) [FSB50550AB](#)
[NCV70501DW002G](#) [LC898301XA-MH](#) [LV8413GP-TE-L-E](#) [MSVGW45-14-3](#) [MSVGW45-14-4](#) [MSVGW45-14-5](#) [MSVGW54-14-4](#)
[STK984-091A-E](#) [SLA7026M](#) [MP6519GQ-Z](#) [LB11651-E](#) [IRSM515-025DA4](#) [LV8127T-TLM-H](#) [NCP81382MNTXG](#) [TDA21801](#)
[LB11851FA-BH](#) [NCV70627DQ001R2G](#)