



Dual-Output Remote-Junction Temperature Switches

MAX6685/MAX6686

General Description

MAX6685/MAX6686 are dual-output temperature switches that use an external diode-connected transistor as a sensing element. These devices have two logic outputs (T_{HIGH} and T_{LOW}). T_{HIGH} asserts a logic signal when the remote temperature crosses the factory-programmed, +120°C, or +125°C upper trip threshold. T_{LOW} is asserted when the remote temperature exceeds the lower threshold, which is controlled by pins S1 and S2. The lower thresholds are available in two ranges in 5°C increments. The two ranges are +40°C to +80°C and +75°C to +115°C. Hysteresis for both outputs to be deasserted is typically 5°C.

T_{HIGH} is an open-drain, active-low output for both the MAX6685 and the MAX6686. T_{LOW} is a CMOS push-pull, active-high output for the MAX6685 and is an open-drain, active-low output for the MAX6686. They are available in a space-saving 8-pin μ MAX package.

Applications

CPU Temperature Protection	Multichip Modules
Fan Control	FPGA Temperature Protection

Features

- ◆ Pin-Programmed Lower Temperature Threshold from +40°C to +80°C or +75°C to +115°C (5°C Increments)
- ◆ Preset Upper Threshold: +120°C or +125°C
- ◆ Open-Drain, Active-Low Output for Upper Temperature Alarm
- ◆ CMOS Push-Pull, Active-High or Open-Drain, Active-Low Output for Lower Temperature Alarm
- ◆ 1.5°C Accuracy
- ◆ 3.0V to 5.5V, 200 μ A Supply
- ◆ 8-Pin μ MAX Package

Pin Configurations appear at end of data sheet.

Ordering Information

PART	T_{LOW} OUTPUT	T_{LOW} TRIP RANGE (0°C)	T_{HIGH} TRIP THRESHOLD (0°C)	PIN-PACKAGE
MAX6685AU40L	Push-pull, active high	+40°C to +80°C	+120°C	8 μ MAX
MAX6685AU40H	Push-pull, active high	+40°C to +80°C	+125°C	8 μ MAX
MAX6685AU75L	Push-pull, active high	+75°C to +115°C	+120°C	8 μ MAX
MAX6685AU75H	Push-pull, active high	+75°C to +115°C	+125°C	8 μ MAX
MAX6686AU40L	Open drain, active low	+40°C to +80°C	+120°C	8 μ MAX
MAX6686AU40H	Open drain, active low	+40°C to +80°C	+125°C	8 μ MAX
MAX6686AU75L	Open drain, active low	+75°C to +115°C	+120°C	8 μ MAX
MAX6686AU75H	Open drain, active low	+75°C to +115°C	+125°C	8 μ MAX

Typical Operating Circuits

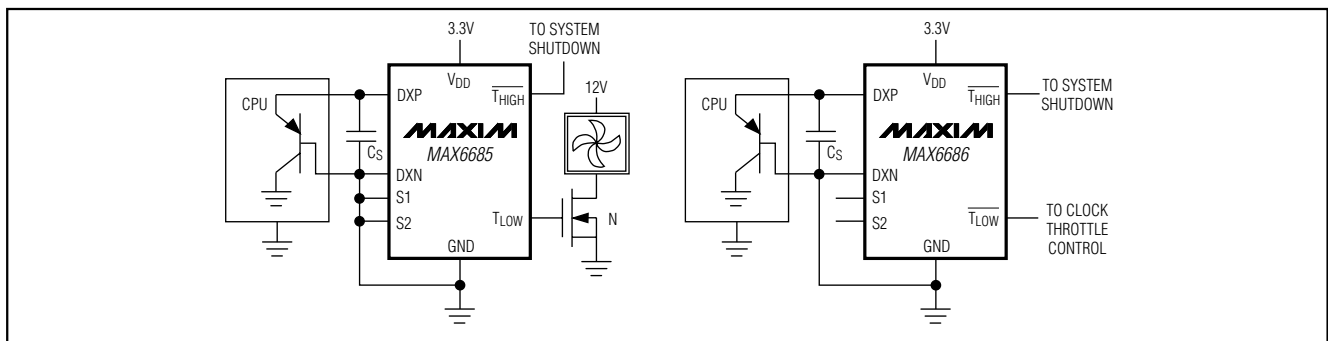

Dual-Output Remote-Junction Temperature Switches

ABSOLUTE MAXIMUM RATINGS

Voltages Referenced to GND

V _{DD} , T _{LOW} , T _{HIGH}	-0.3V to +6V
DXN	-0.3V to +0.8V
All Other Pins	-0.3V to (V _{DD} + 0.3V)
Input Current	5mA
Output Current	20mA

Continuous Power Dissipation (T_A = +70°C)

8-Pin μMAX (derate 4.1mW/°C above +70°C)	330mW
Operating Temperature Range	-40°C to +125°C
Junction Temperature	+150°C
Storage Temperature Range	-65°C to +165°C
Lead Temperature (soldering, 10s)	+300°C

Stresses beyond those listed under "Absolute Maximum Ratings" may cause permanent damage to the device. These are stress ratings only, and functional operation of the device at these or any other conditions beyond those indicated in the operational sections of the specifications is not implied. Exposure to absolute maximum rating conditions for extended periods may affect device reliability.

ELECTRICAL CHARACTERISTICS

(V_{DD} = 3.0V to 5.5V, T_A = -40°C to +125°C, unless otherwise noted. Typical values are at V_{DD} = 3.3V and T_A = +25°C.) (Note 1)

PARAMETER	SYMBOL	CONDITION	MIN	TYP	MAX	UNITS
Power-Supply Range	V _{DD}		3.0		5.5	V
Average Supply Current	I _{DD}			200	500	μA
Supply Current During Conversion				400	800	μA
Power-On Reset Threshold	POR	V _{DD} falling edge	1.0	1.5	2.0	V
POR Threshold Hysteresis				50		mV
Temperature Threshold Accuracy	ΔT _{TH}	V _{DD} = 3.3V, T _A = +25°C, T _{RJ} = 0°C to +125°C (Note 2)	-1.5		+1.5	°C
		T _A = 0°C to +100°C, T _{RJ} = 0°C to +125°C		2.0		
Temperature Threshold Hysteresis	T _{HYST}			5.0		°C
Supply Sensitivity of Temperature Threshold		T _A = +25°C, T _{RJ} = 0°C to +125°C, V _{DD} = 3.0V to 5.5V			0.6	°C/V
Output Voltage High	V _{OH}	I _{SOURCE} = 1mA, MAX6685 T _{LOW} only	V _{DD} - 0.2			V
Output Voltage Low	V _{OL}	I _{SINK} = 1mA			0.2	V
Logic-Low Input Voltage	V _{IL}	S1, S2			0.4	V
Logic-High Input Voltage	V _{IH}	S1, S2	1.8			V
Input Current		S1, S2			10	μA
Open-Drain Output Leakage Current		V _{OUT} = 5.5V, T _{LOW} and T _{HIGH}			1	μA
Conversion Time			0.09	0.11	0.13	s
Sample Period			0.35	0.45	0.55	s
Current Sourcing for External Diode		High level	80	100	120	μA
		Low level	8	10	12	

Note 1: All parameters are tested at +25°C. Temperature specifications over a range of -40°C to +125°C are guaranteed by design.

Note 2: T_{RJ} is the temperature of the remote-sensing diode junction.

Dual-Output Remote-Junction Temperature Switches

Typical Operating Characteristics

($V_{DD} = 3.3V$, $C_S = 2200pF$, $T_A = +25^\circ C$, unless otherwise noted. See *Typical Operating Circuits*.)

MAX6685/MAX6686

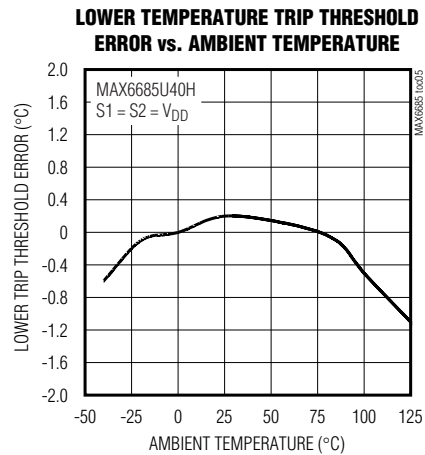
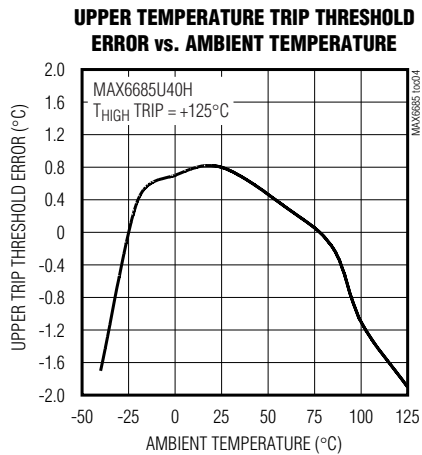
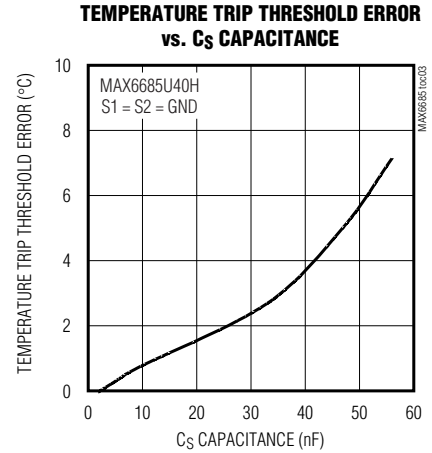
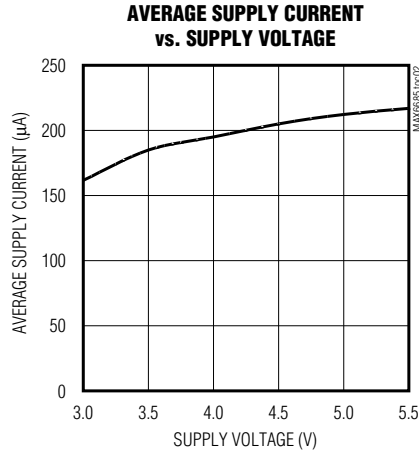
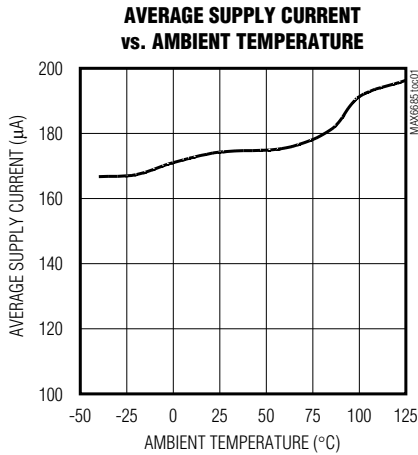

Dual-Output Remote-Junction Temperature Switches

Pin Description

PIN		NAME	FUNCTION
MAX6685	MAX6686		
1	1	V _{DD}	Power-Supply Input. Bypass to GND with a 0.1μF capacitor.
2	2	GND	Ground
3	3	DXP	This pin connects to the positive (anode) terminal of the external P-N sense junction. It sources current into the external junction. A 2200pF capacitor should be connected across DXP and DXN.
4	4	DXN	This pin connects to the negative (cathode) terminal of the external P-N sense junction. It sinks current from the external junction. A 2200pF capacitor should be connected across DXP and DXN. DXN must be connected to the GND pin with the shortest possible connection.
5	5	\overline{T}_{HIGH}	Open-Drain, Active-Low Output. \overline{T}_{HIGH} goes low when the temperature exceeds the factory-programmed upper temperature threshold, either +120°C or +125°C. Connect a pullup resistor (typically 10kΩ) between \overline{T}_{HIGH} and a positive supply up to 5.5V.
6	—	T _{LOW}	CMOS Push-Pull, Active-High Output. T _{LOW} goes HIGH when the temperature exceeds the pin-programmed lower temperature threshold.
—	6	\overline{T}_{LOW}	Open-Drain, Active-Low Output. \overline{T}_{LOW} goes LOW when the temperature exceeds the pin-programmed lower temperature threshold. Connect a pullup resistor (typically 10kΩ) between \overline{T}_{LOW} and a positive supply up to 5.5V.
7	7	S1	Threshold Select Input. Used in conjunction with S2 to set the lower threshold for T _{LOW} (Table 1). It can be connected to V _{DD} , GND, or left floating.
8	8	S2	Threshold Select Input. Used in conjunction with S1 to set the lower threshold for T _{LOW} (Table 1). It can be connected to V _{DD} , GND, or left floating.

Detailed Description

The MAX6685/MAX6686 dual-output remote-sensing junction temperature switches incorporate a precision remote-junction temperature sensor and two comparators. These devices use an external P-N junction as the temperature-sensing element (see *Typical Operating Circuits*).

The MAX6685/MAX6686 provide noise immunity by integration and oversampling of the diode voltage, but good design practice includes routing the DXP and DXN lines away from noise sources, such as high-speed digital lines, switching regulators, inductors, and transformers. The DXP and DXN traces should be paired together and surrounded by a ground plane whenever possible.

The 5°C hysteresis keeps the outputs from “chattering” when the measured temperature is close to the threshold temperature. The MAX6685/MAX6686 are available with preset upper temperature thresholds of +120°C or +125°C. The lower temperature thresholds are pin programmable in 5°C increments (Table 1). Two tempera-

ture ranges are available for the lower trip threshold: +40°C to +80°C and +75°C to +115°C. S1 and S2 pins must be set to the desired trip temperature before power is applied to the V_{DD} pin. If this is done after the power is turned on, the lower trip threshold remains set to the point where S1 and S2 were when power was applied.

Applications Information

Remote-Diode Selection

The MAX6685/MAX6686 are optimized to measure the die temperature of CPUs and other ICs that have on-chip temperature-sensing diodes. These on-chip diodes are substrate PNPs with their collectors grounded. Connect the base of the PNP to DXN and the emitter to DXP. When using a discrete, diode-connected NPN or PNP as a sensing diode, use a good-quality small-signal device. Examples are listed in Table 2. Tight specifications for forward current gain indicate the manufacturer has good process controls and that the devices have consistent V_{be} characteristics. Always use a transistor for the sensing junction; diodes do not work.

Dual-Output Remote-Junction Temperature Switches

MAX6685/MAX6686

Table 1. Lower Temperature Trip Threshold Selection

S1	S2	MAX6685AUA40L MAX6685AUA40H MAX6686AUA40L MAX6686AUA40H	MAX6685AUA75L MAX6685AUA75H MAX6686AUA75L MAX6686AUA75H
		LOWER TEMPERATURE TRIP THRESHOLD (°C)	LOWER TEMPERATURE TRIP THRESHOLD (°C)
GND	GND	+40	+75
GND	FLOAT	+45	+80
GND	V _{DD}	+50	+85
FLOAT	GND	+55	+90
FLOAT	FLOAT	+60	+95
FLOAT	V _{DD}	+65	+100
V _{DD}	GND	+70	+105
V _{DD}	FLOAT	+75	+110
V _{DD}	V _{DD}	+80	+115

Noise-Filtering Capacitors

A quality ceramic capacitor must be connected across the DXP/DXN inputs to maintain temperature threshold accuracy by filtering out noise. The capacitor should be located physically close to the DXP/DXN pins and should typically have a value of 2200pF. Larger capacitor values can cause temperature measurement errors. A 50% variation from the recommended capacitor value can cause up to ±1°C error.

Table 2. Sensor Transistor Manufacturers

MANUFACTURER	MODEL NO.
Central Semiconductor (USA)	CMPT3904
ON Semiconductor (USA)	2N3904, 2N3906
Rohm Semiconductor (Japan)	SST3904
Samsung (Korea)	KST3904-TF
Siemens (Germany)	SMBT3904

Note: Discrete transistors must be diode connected (base shorted to collector).

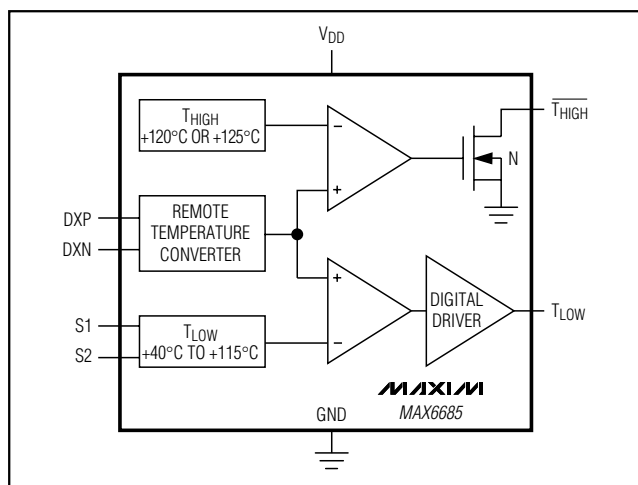

Figure 1. MAX6685 Functional Diagram

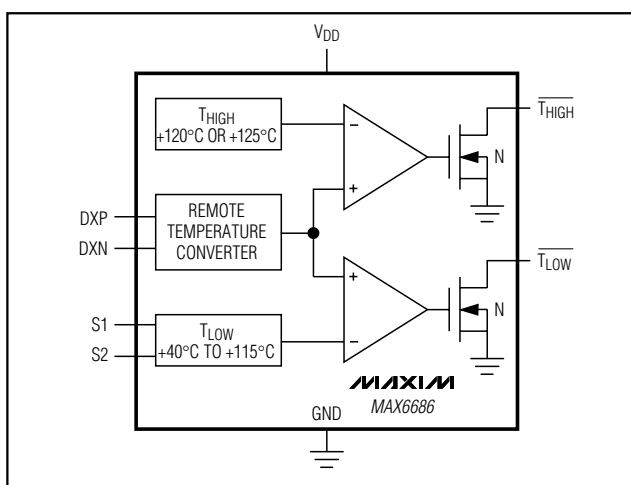
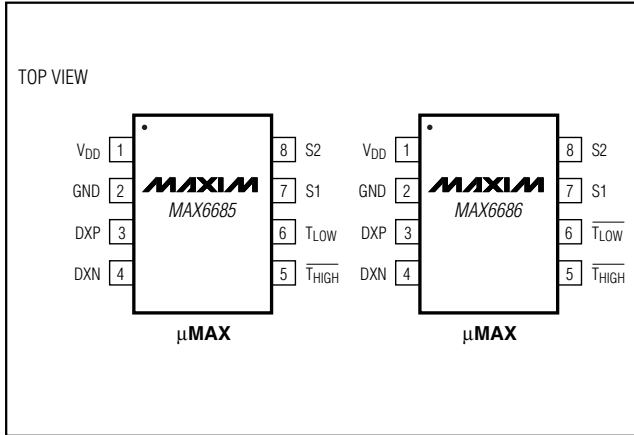

Figure 2. MAX6686 Functional Diagram

Dual-Output Remote-Junction Temperature Switches

Pin Configurations



Chip Information

TRANSISTOR COUNT: 7765

PROCESS: BiCMOS

Dual-Output Remote-Junction Temperature Switches

Package Information

(The package drawing(s) in this data sheet may not reflect the most current specifications. For the latest package outline information, go to www.maxim-ic.com/packages.)

MAX6685/MAX6686

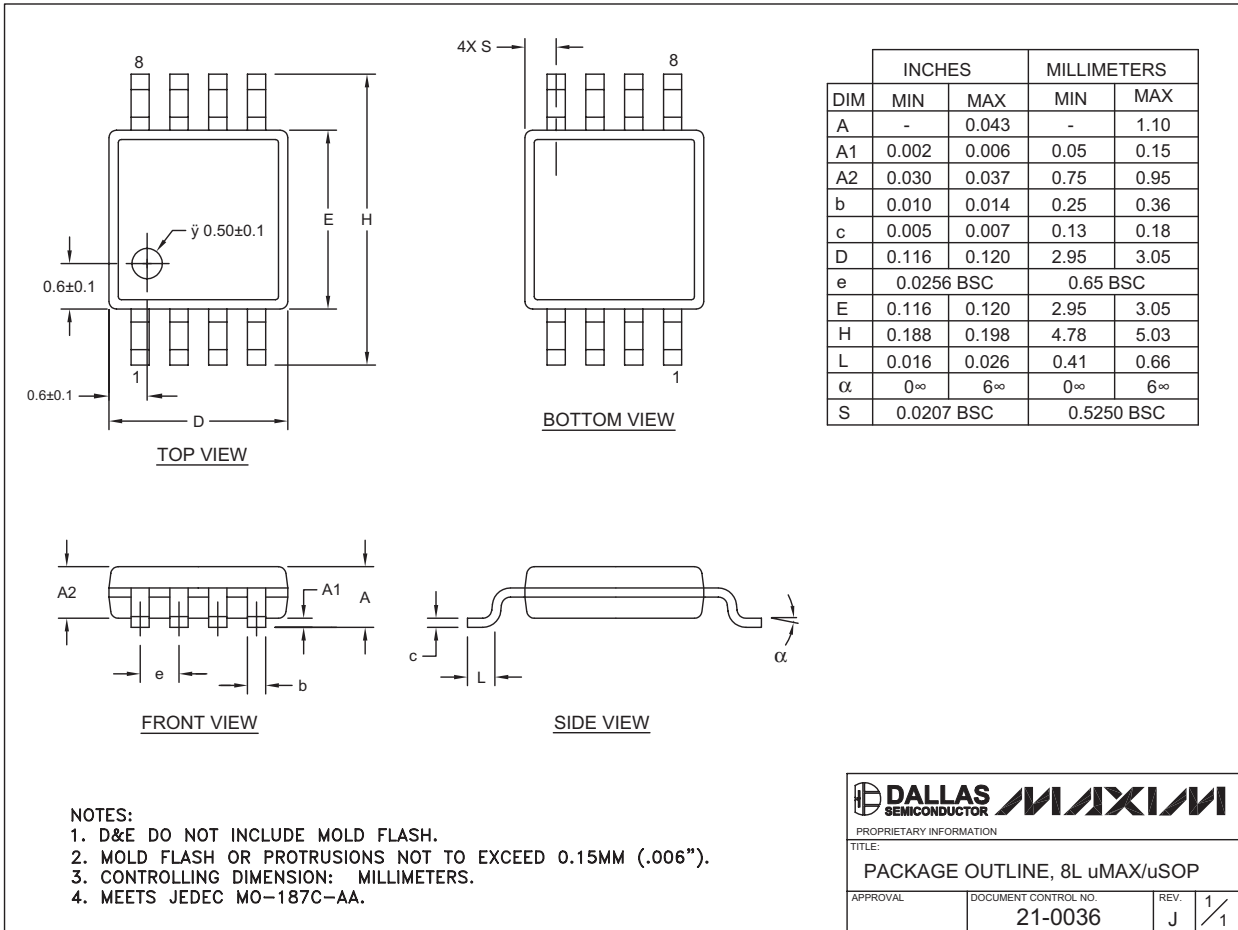

Maxim cannot assume responsibility for use of any circuitry other than circuitry entirely embodied in a Maxim product. No circuit patent licenses are implied. Maxim reserves the right to change the circuitry and specifications without notice at any time.

Maxim Integrated Products, 120 San Gabriel Drive, Sunnyvale, CA 94086 408-737-7600 7

X-ON Electronics

Largest Supplier of Electrical and Electronic Components

Click to view similar products for [Board Mount Temperature Sensors](#) category:

Click to view products by [Maxim](#) manufacturer:

Other Similar products are found below :

[5962-8757102XA](#) [66F115](#) [EMC1063-1-ACZL-TR](#) [NCT218FCT2G](#) [O53GAB175A-160Y](#) [3610085020002](#) [389049M9527](#) [MIKROE-912](#)
[ADM1023ARQZ-REEL](#) [ADM1032ARMZ-1RL](#) [AT30TS74-U1FMBB-T](#) [AT30TS74-U1FMAB-T](#) [AT30TS74-U1FMCB-T](#) [AT30TS74-](#)
[U1FMDB-T](#) [ADT7483AARQZ-RL](#) [ADT7481ARMZ-REEL](#) [ADT7463ARQZ-REEL](#) [MCP98243T-BE/MC](#) [66L080-0226](#) [5962-8757103XA](#)
[S-58LM20A-I4T1U](#) [NCT375MNR2G](#) [LM84CIMQA](#) [CAT34TS00VP2GT4A](#) [NCT80DBR2G](#) [SEN-16304](#) [GX21M15](#) [GX122](#) [NST175H-](#)
[QSPR](#) [TC6501P065VCTTR](#) [AT-1U](#) [MCP9700AT-E/LT](#) [MCP9701-E/TO](#) [MCP9803-M/MS](#) [MCP9701A-E/TO](#) [LM57FEPWQ1](#) [LM57FPW](#)
[LM57FSPWQ1](#) [60-41123102-0150.0010](#) [60-43123102-0150.0010](#) [60-53123102-0150.0010](#) [MLX90615SSG-DAA-000-TU](#) [TMP303CDRLR](#)
[TC6501P055VCTTR](#) [TC6503P005VCTTR](#) [ADT7311WTRZ-RL](#) [ADT7311WTRZ-RL7](#) [ADT7473ARQZ-REEL](#) [LM335AM](#)
[LM335AM/NOPB](#)