



+10V Precision Voltage Reference

MAX674

General Description

The MAX674 is a precision voltage reference that is pretrimmed to within $\pm 0.15\%$ of 10V. The reference features excellent temperature stability (as low as 12.0ppm/ $^{\circ}\text{C}$ guaranteed), low current drain, and low noise. It is supplied in the space-saving narrow SO package, as well as, the standard 8-pin plastic DIP package.

Features

- ◆ Pretrimmed to +10V, $\pm 0.15\%$
- ◆ Excellent Temperature Stability: 12ppm/ $^{\circ}\text{C}$
- ◆ Low Noise: 20 $\mu\text{Vp-p}$
- ◆ Low Supply Current: 1.4mA (max)
- ◆ Short-Circuit Protected
- ◆ Load Regulation 0.001%/mA
- ◆ Pin-for-Pin Compatible with REF01

Applications

A/D Converters
D/A Converters
Digital Voltmeters
Voltage Regulators
Threshold Detectors

Ordering Information

PART	TEMP RANGE	PIN-PACKAGE	TEMPCO (ppm/ $^{\circ}\text{C}$)	INITIAL ERROR (mV)
MAX674CPA	0 $^{\circ}\text{C}$ to +70 $^{\circ}\text{C}$	8 PDIP	12	15
MAX674CSA	0 $^{\circ}\text{C}$ to +70 $^{\circ}\text{C}$	8 Narrow SO	12	15
MAX674EPA	-40 $^{\circ}\text{C}$ to +85 $^{\circ}\text{C}$	8 PDIP	15	15
MAX674ESA	-40 $^{\circ}\text{C}$ to +85 $^{\circ}\text{C}$	8 Narrow SO	15	15

Ordering Information continued at end of data sheet.

Pin Configurations

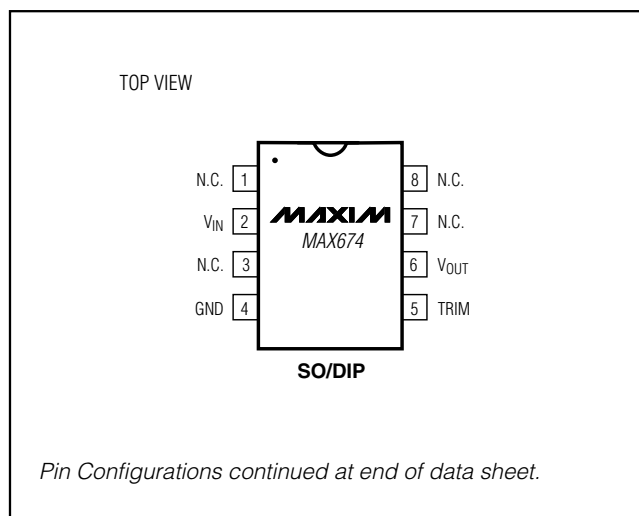

Typical Operating Circuit

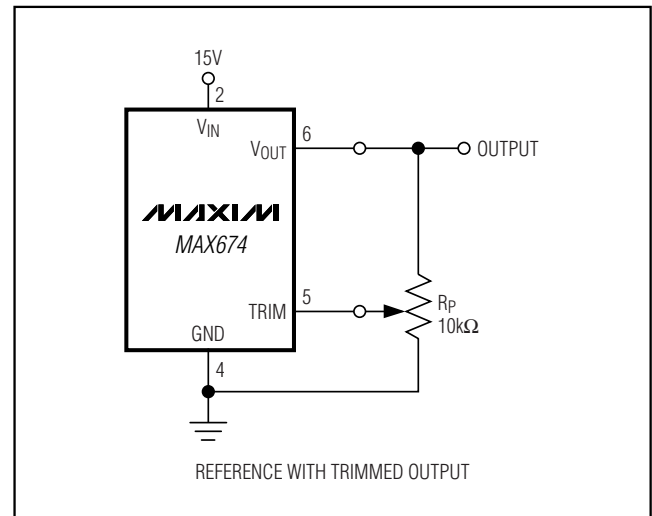

+10V Precision Voltage Reference

ABSOLUTE MAXIMUM RATINGS

Input Voltage	40V	Operating Temperature Range	
Power Dissipation		MAX674C	0°C to +70°C
TO-99 (TV) (derate at 7.1mW/ C above +80°C).....	500mW	MAX674E	-40°C to +85°C
CERDIP (J) (derate at 6.7mW/ C above +75°C).....	500mW	MAX674M	-55°C to +125°C
Plastic DIP (P) (derate at 5.6mW/ C above +36°C)	500mW	Dice Junction Temperature (T _J)	-65°C to +150°C
Narrow SO (S) (derate at 5.0mW/ C above +55°C).....	300mW	Output Short-Circuit Duration	
Storage Temperature Range	-65°C to +150°C	(to Ground or V _{IN}).....	Indefinite
		Lead Temperature (soldering, 60s).....	+300°C

Stresses beyond those listed under "Absolute Maximum Ratings" may cause permanent damage to the device. These are stress ratings only, and functional operation of the device at these or any other conditions beyond those indicated in the operational sections of the specifications is not implied. Exposure to absolute maximum rating conditions for extended periods may affect device reliability.

ELECTRICAL CHARACTERISTICS

(V_{IN} = +15V, T_A = +25°C, unless otherwise noted.)

PARAMETER	SYMBOL	CONDITIONS	MIN	TYP	MAX	UNITS
Output Voltage Tolerance		I _L = 0mA			±15	mV
Output Voltage Temperature Coefficient (Note 1)	TCV _O	MAX674CTV/CPA/CSA			12	ppm/°C
		MAX674ETV/EJA/EPA/ESA			15	
		MAX674MTV/MJA			20	
Output Adjustment Range	V _{TRIM}	R _p = 10	±300	±600		mV
Line Regulation (Note 2)		V _{IN} = 13V to 33V		0.006	0.01	%/V
Load Regulation (Note 2)		I _L = 0 to 10mA		0.001	0.002	%/mA
Turn-On Settling Time	t _{ON}	To ±0.1% of final value		5		μs
Quiescent Supply Current	I _Q	No load		750	1400	μA
Noise (Note 3)	e _{N(P-P)}	0.1Hz to 10Hz		20	30	μV _{P-P}
Sink Current	I _S		0.3	0.5		mA
Short-Circuit Current	I _{SC}	V _{OUT} = 0V		30		mA

Note 1: Temperature coefficient is measured by the "box" method, i.e., the maximum ΔV_{OUT} is divided by ΔT.

Note 2: Line and load regulation specifications include the effect of self-heating.

Note 3: Guaranteed by design for MAX674CPA, MAX674CSA, MAX674EPA, MAX674ESA; sample tested for all other grades and packages.

+10V Precision Voltage Reference

Output Adjustment

The MAX674 trim terminal can be used to adjust the output voltage over a 10V \pm 300mV range. This feature allows system errors to be trimmed by setting the reference to a voltage other than 10V such as 10.240V for binary applications (see the *Typical Operating Circuit*). The trim terminal may, of course, be left open if no adjustment is needed.

Adjustment of the output does not significantly affect the temperature performance of the device. The temperature coefficient change is approximately 0.7ppm/ $^{\circ}$ C for 100mV of output adjustment from its initial value.

Typical Operating Characteristics

($T_A = +25^{\circ}$ C, unless otherwise noted.)

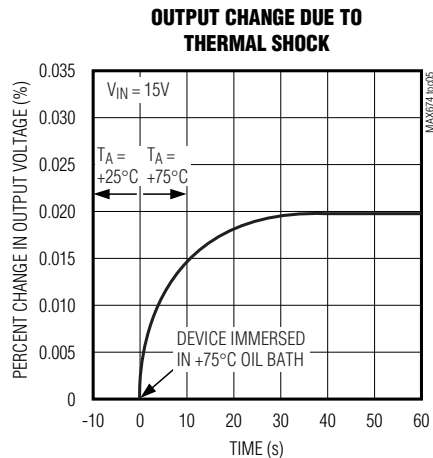
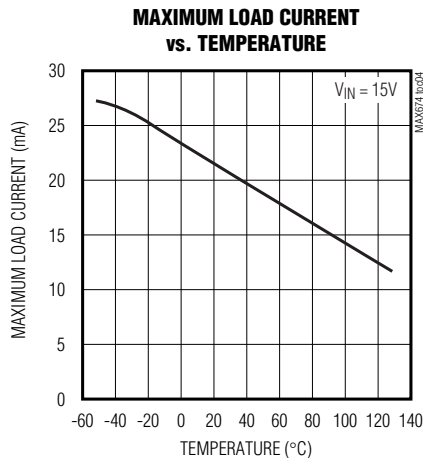
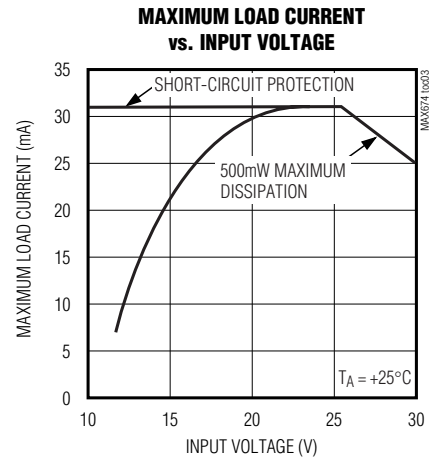
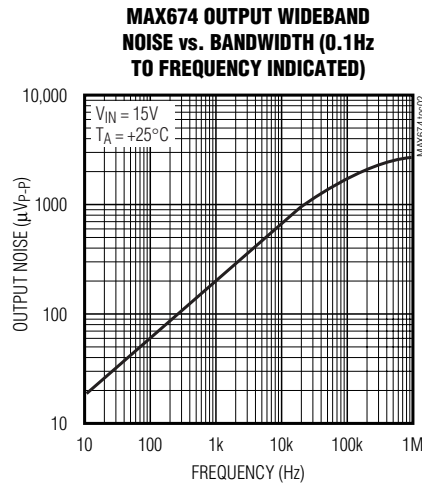
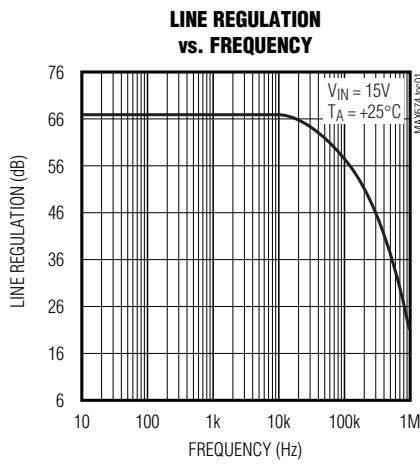

+10V Precision Voltage Reference

Typical Applications

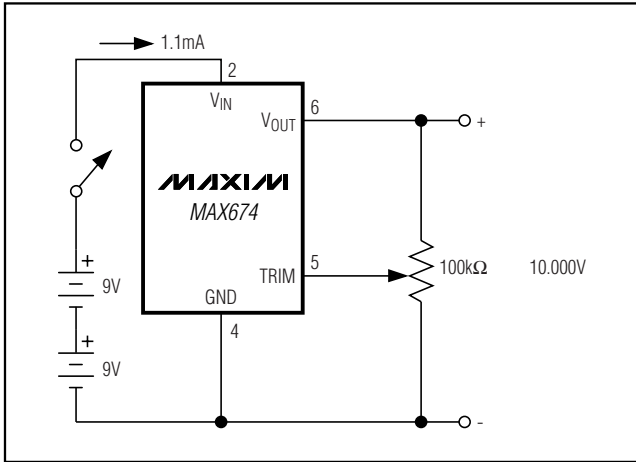

Figure 2. Precision Calibration Standard

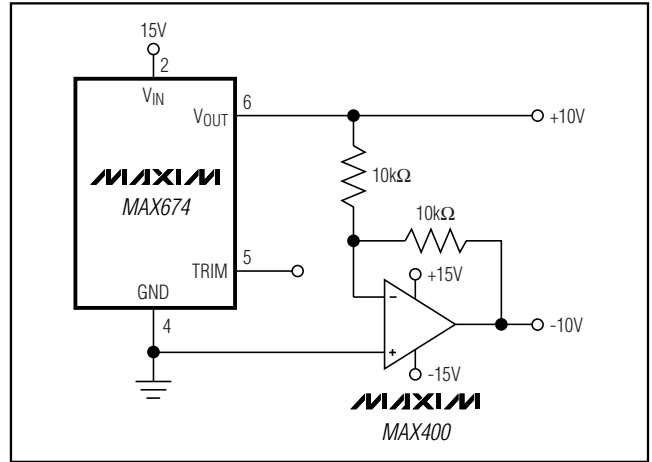

Figure 3. ±10V Reference

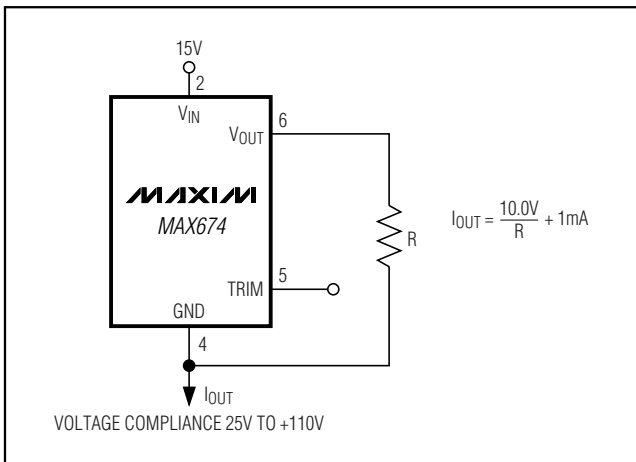

Figure 4. Current Source

$$I_{OUT} = \frac{10.0V}{R} + 1mA$$

VOLTAGE COMPLIANCE 25V TO +110V

+10V Precision Voltage Reference

MAX674

Pin Configurations (continued)

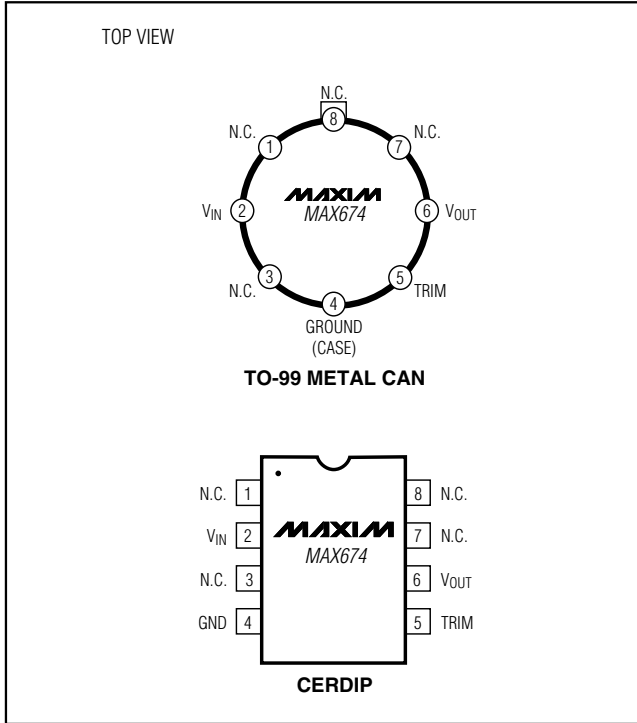

Chip Topography

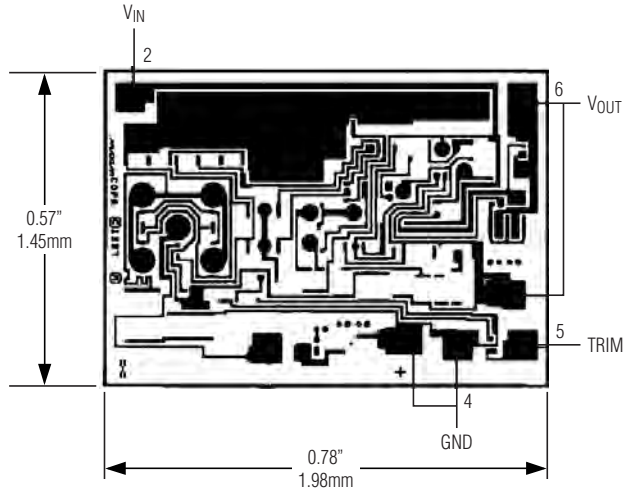

Ordering Information (continued)

PART	TEMP RANGE	PIN-PACKAGE	TEMPCO (ppm/°C)	INITIAL ERROR (mV)
MAX674CTV*	0°C to +70°C	8 TO-99	12	15
MAX674ETV*	-40°C to +85°C	8 TO-99	15	15
MAX674EJA*	-40°C to +85°C	8 CERDIP	15	15
MAX674MTV*	-55°C to +125°C	8 TO-99	20	15
MAX674MJA*	-55°C to +125°C	8 CERDIP	20	15

*Contact factory for availability. Not recommended for new designs.

Maxim cannot assume responsibility for use of any circuitry other than circuitry entirely embodied in a Maxim product. No circuit patent licenses are implied. Maxim reserves the right to change the circuitry and specifications without notice at any time.

Maxim Integrated Products, 120 San Gabriel Drive, Sunnyvale, CA 94086 408-737-7600 _____ 5

X-ON Electronics

Largest Supplier of Electrical and Electronic Components

Click to view similar products for [Voltage References](#) category:

Click to view products by [Maxim](#) manufacturer:

Other Similar products are found below :

[REF01J/883](#) [5962-8686103XC](#) [NCV431BVDMR2G](#) [LT6654AMPS6-2.048#TRMPBF](#) [SCV431AIDMR2G](#) [LT1019AIS8-2.5](#)
[LT6654AMPS6-3.3#TRM](#) [SC431ILPRAG](#) [AP432AQG-7](#) [NJM2823F-TE1](#) [TL431-A](#) [MCP1502T-18E/CHY](#) [MCP1502T-40E/CHY](#)
[TL431ACZ](#) [KA431SLMF2TF](#) [KA431SMF2TF](#) [KA431SMFTF](#) [LM4040QCEM3-3.0/NOPB](#) [LM4041C12ILPR](#) [LM4120AIM5-2.5/NOP](#)
[LM431SCCMFX](#) [TS3330AQPR](#) [REF5040MDREP](#) [LM285BXM3-1.2/NOPB](#) [LM385BM-2.5/NOPB](#) [LM4040AIM3-10.0](#) [LM4040BIM3-4.1](#)
[LM4040CIM3-10.0](#) [LM4040CIM3X-2.0/NOPB](#) [LM4041BSD-122GT3](#) [LM4041QDIM3-ADJ/NO](#) [LM4050QAEM3X4.1/NOPB](#)
[LM4051BIM3-ADJ/NOPB](#) [LM4051CIM3X-1.2/NOPB](#) [LM4128CMF-1.8/NOPB](#) [LM4132DMF-1.8/NOPB](#) [LM4132EMF-1.8/NOPB](#)
[LM4132EMF-2.0/NOPB](#) [LM4140CCMX-1.2/NOPB](#) [LM431CIM](#) [LM385BD-2.5R2G](#) [LM385M-2.5/NOPB](#) [LM4030AMF-4.096/NOPB](#)
[LM4040D30ILPR](#) [LM4051CIM3X-ADJ/NOPB](#) [AP432YG-13](#) [AS431ANTR-G1](#) [AS431BZTR-E1](#) [AN431AN-ATRG1](#) [AP431IBNTR-G1](#)