

General Description

The MAX77231 evaluation kit (EV kit) is a fully assembled and tested PCB for evaluating the MAX77231 low-noise step-up DC-DC converter. It is optimized for boost applications requiring very low ripple/noise and small PCB space. The EV kit is set up to provide an 11.2V output from an input voltage ranging from 2.7V to 4.8V, and can deliver up to 10mA of current. The output ripple and noise are suppressed to 35µV_{RMS}. Other output voltages up to 16.2V can be factory set. Jumpers are provided to help evaluate features of the MAX77231 IC.

Features

- Ultra-Small Solution Circuit Area (< 7mm²)
- 35µV_{RMS} Typical Output Ripple/Noise
- 2.7V to 4.8V Input Range
- 11.2V/10mA Output
- Output Factory-Trimable from 11.2V to 16.2V
- 125µA No-Load Supply Current—Output On
- < 1µA Shutdown Supply Current
- True Shutdown Load Disconnect
- Selectable Active Discharge
- Proven PCB layout
- Fully Assembled and Tested

***Ordering Information** appears at end of data sheet.*

Quick Start

Recommended Equipment

- MAX77231 EV kit
- 2.5V to 6V 100mA bench power supply (PS1)
- Two digital multimeters (DMM1, DMM2)
- 0–50mA electronic load or appropriate load resistors

Procedure

The EV kit is a fully assembled and tested surface mount circuit board. Follow the steps below to set up and verify the IC and board operation:

- 1) Verify that the jumpers on the EV kit are configured as shown in [Table 1](#).
- 2) If using an electronic load, set it to 6mA and turn it off. Alternately, obtain a 2kΩ resistor (values from 1.8kΩ to 2.4kΩ are also acceptable).
- 3) Set the power supply to 3.6V and turn it off.
- 4) Connect the MAX77231 evaluation board, bench power supply and DMMs as shown in [Figure 1](#).
- 5) Turn on the power supply.
- 6) Verify that voltage read by DMM1 is 3.6V.
- 7) Verify that voltage read by DMM2 is 11.2V.
- 8) Sweep the power supply down to 2.7V.
- 9) Verify that voltage read by DMM2 is 11.2V.
- 10) Sweep the power supply up to 4.8V.
- 11) Verify that voltage read by DMM2 is 11.2V.
- 12) Disconnect RL (or electronic load).
- 13) Verify that voltage read by DMM2 is 11.2V.

Table 1. Default Jumper Settings

JUMPER	DEFAULT SHUNT POSITION	MODE
JU1	1-2	Active Discharge Off
JU2	1-2	Power On

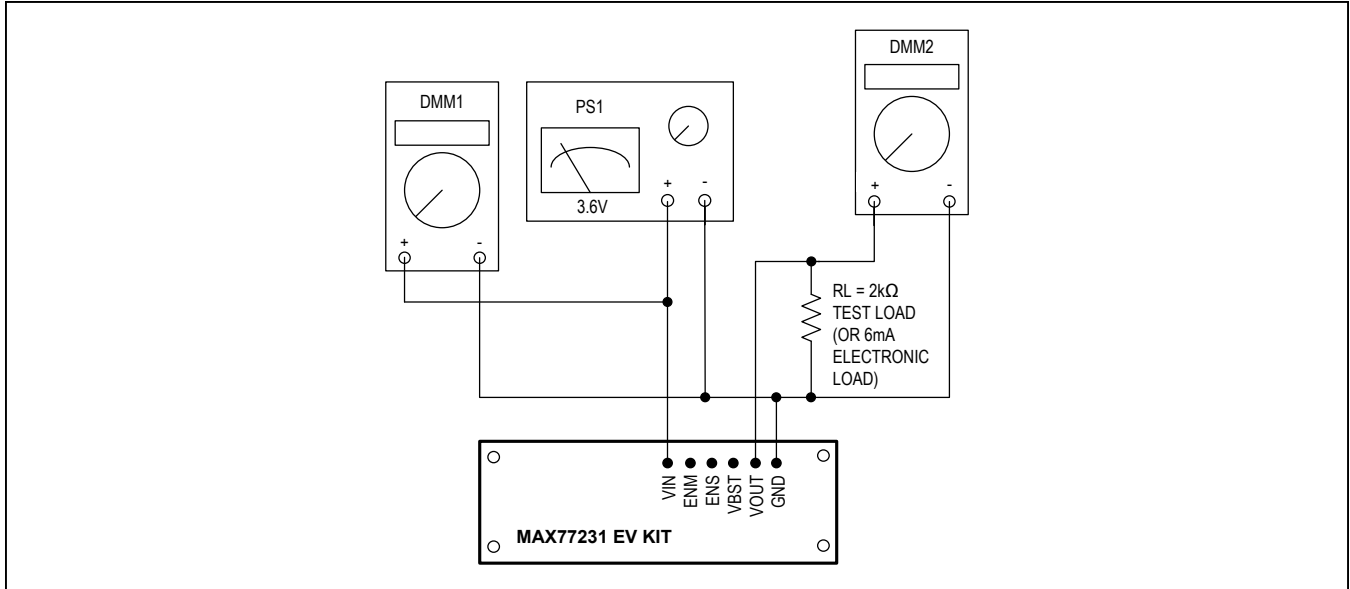

Figure 1. Quick-Start Connection Diagram

Detailed Description

The MAX77231 EV kit evaluates the MAX77231 low-noise boost DC-DC converter IC. The IC utilizes a high-frequency PFM boost followed by a low-noise pMOS linear LDO regulator that reduces output noise and ripple to $35\mu V_{RMS}$ in a 1MHz BW at V_{OUT} .

The step-up converter output is 11.7V at V_{BST} , and 11.2V at V_{OUT} from an input voltage range from 2.7V to 4.8V. Other output voltages up to 16.2V are available after replacing U1. Contact the factory for other ICs.

Enable/Active Discharge

The MAX77231 can be disabled with/without active discharge. See [Table 2](#) for ENM and ENS control logic for active discharge.

Overload and Short Circuit Protection

The MAX77231 is fully protected against output short circuits. In the case of a short circuit, off time is lengthened to prevent inductor current from climbing. The device will source current into the short indefinitely, without damage, until the short is removed.

Note, however, that only OUT (and not BST) is overload protected. A short at V_{BST} to ground may cause inductor and LX current to rise above guaranteed operating levels.

Table 2. MAX77231 Enable Truth Table

JU1		JU2		POWER STATE	ACTIVE DISCHARGE
JUMPER POSITION	ENM	JUMPER POSITION	ENS		
2-3	0	X	X	Power Down	ON
1-2	1	2-3	0	Power Down	OFF
1-2	1	1-2	1	Active	OFF

Component Suppliers

SUPPLIER	WEBSITE
Taiyo Yuden	www.t-yuden.com
Cyntec	www.cyntec.com

Note: Indicate that you are ordering the MAX77231 EV kit when contacting these suppliers.

Component List, PCB Layout, and Schematic

See the following links for component information, PCB layout diagrams, and schematics.

- [MAX77231 EV BOM](#)
- [MAX77231 EV PCB Layout](#)
- [MAX77231 EV Schematic](#)
- [MAX77231 EV Minimal Component Schematic](#)

Ordering Information

PART	TYPE
MAX77231EVKIT#	EV Kit

#Denotes RoHS compliant.

Revision History

REVISION NUMBER	REVISION DATE	DESCRIPTION	PAGES CHANGED
0	1/16	Initial release	—

For pricing, delivery, and ordering information, please contact Maxim Direct at 1-888-629-4642, or visit Maxim Integrated's website at www.maximintegrated.com.

Maxim Integrated cannot assume responsibility for use of any circuitry other than circuitry entirely embodied in a Maxim Integrated product. No circuit patent licenses are implied. Maxim Integrated reserves the right to change the circuitry and specifications without notice at any time.

TITLE: Bill of Materials							
DATE: 12/11/2015							
DESIGN: max77231_evkit_b							
NOTE: DNI--> DO NOT INSTALL ; DNP--> DO NOT PROCURE							
ITEM	REF_DES	DNI/DNP	QTY	MFG PART #	MANUFACTURER	VALUE	DESCRIPTION
1	C1	-	1	LMK107BJ225KA	TAIYO YUDEN	2.2UF	CAPACITOR; SMT (0603); CERAMIC CHIP; 2.2UF; 10% TOL=10%; TG=-55 DEGC TO +85 DEGC; TC=X5R
2	C2, C3	-	2	C1608X5R1E225K; TMK107ABJ225KA-T; TMK107BJ225KA	TDK/TAIYO YUDEN	2.2UF	CAPACITOR; SMT (0603); CERAMIC CHIP; 2.2UF; 20% TOL=10%; MODEL=; TG=-55 DEGC TO +85 DEGC; TC=X5R
3	ENM, ENS, VBST	-	3	5000	KEYSTONE	N/A	TEST POINT; PIN DIA=0.1IN; TOTAL LENGTH=0.3IN; BUSH HOLE=0.04IN; RED; PHOSPHOR BRONZE WIRE SILVER FINISH;
4	GND, VIN, PGND, VOUT	-	4	9020 BUSS	WEICO WIRE	MAXIMPAD	EVK KIT PARTS; MAXIM PAD; WIRE; NATURAL; SOLID; WIRE; SOFT DRAWN BUS TYPE-S; 20AWG
5	JU1, JU2	-	2	PEC03SAAN	SULLINS	PEC03SAAN	CONNECTOR; MALE; THROUGH HOLE; BREAKAWAY STRAIGHT; 3PINS
6	L1	-	1	PSB12101T-1R0MSD	CYNTEC	1UH	INDUCTOR; SMT; MAGNETICALLY SHIELDED; 1UH; TOL=20%; 1.12A
7	U1	-	1	MAX77231EZL+	MAXIM	MAX77231EZL+	IC; VREG; ULTRA LOW NOISE BOOST REGULATOR; WIRE
8	H1	DNP	0	PEC06SAAN	SULLINS ELECTRONICS CORP.	PEC06SAAN	CONNECTOR; MALE; THROUGH HOLE; BREAKAWAY STRAIGHT; 6PINS
9	PCB	-	1	MAX77231	MAXIM	PCB	PCB Board:MAX77231 EVALUATION KIT
TOTAL			15				

		<small>This document contains information considered proprietary, and shall not be reproduced wholly or in part, nor disclosed to others without specific written permission.</small>
HARDWARE NAME: MAX77231_EVKIT_B		
HARDWARE NUMBER:		
ENGINEER:	DESIGNER:	
DATE: 12/05/2015	ODB++/GERBER: SILK_TOP	

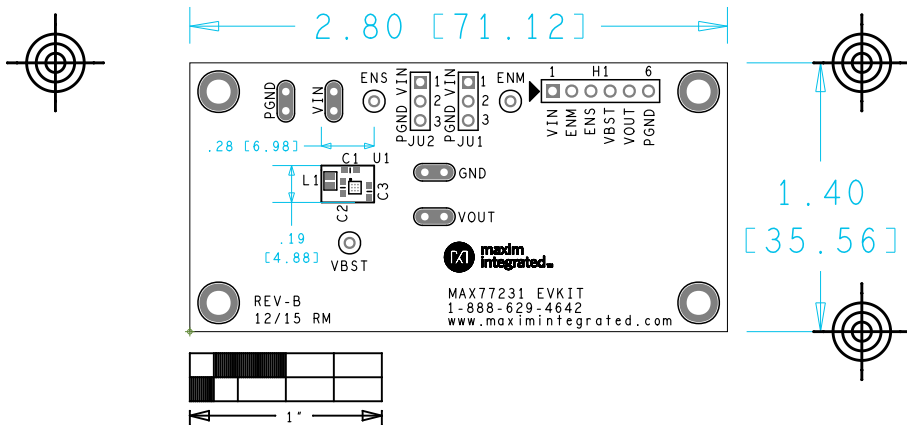

ART FILM - 77231PBLC

		<small>This document contains information considered proprietary, and shall not be reproduced wholly or in part, nor disclosed to others without specific written permission.</small>
HARDWARE NAME: MAX77231_EVKIT_B		
HARDWARE NUMBER:		
ENGINEER:	DESIGNER:	
DATE: 12/05/2015	ODB++/GERBER: TOP	

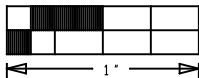
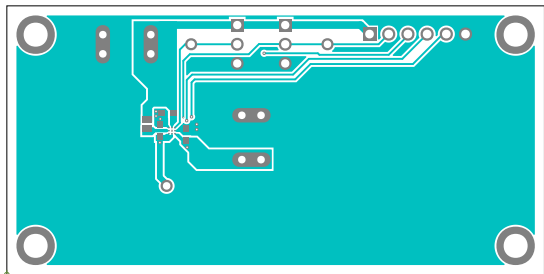

ART FILM - 77231PBL5

		<small>This document contains information considered proprietary, and shall not be reproduced wholly or in part, nor disclosed to others without specific written permission.</small>
HARDWARE NAME: MAX77231_EVKIT_B		
HARDWARE NUMBER:		
ENGINEER:	DESIGNER:	
DATE: 12/05/2015	ODB++/GERBER: BOTTOM	

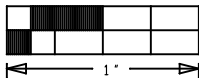
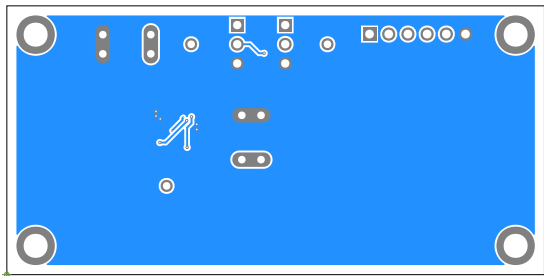

8

7

6

5

D

C

B

A

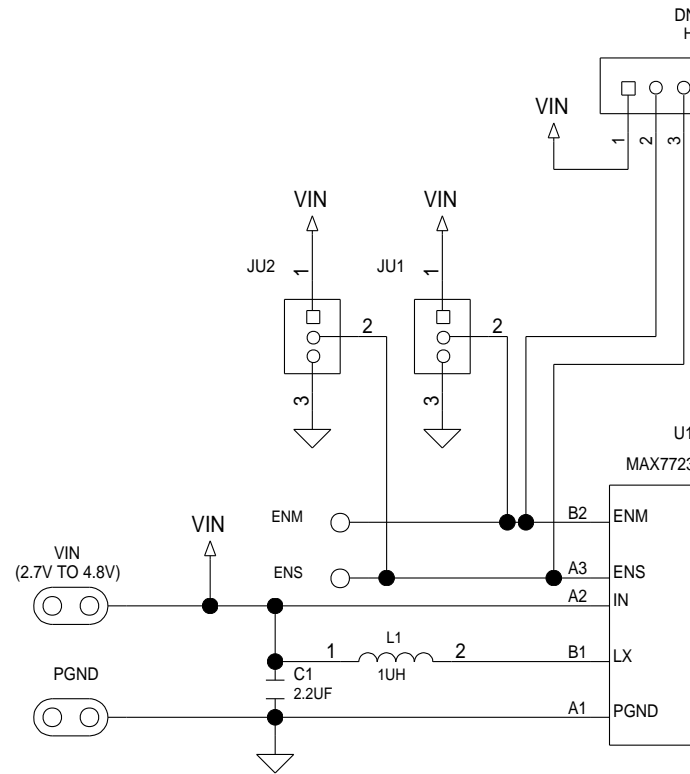

8

7

6

5

D

C

B

A

8

7

6

5

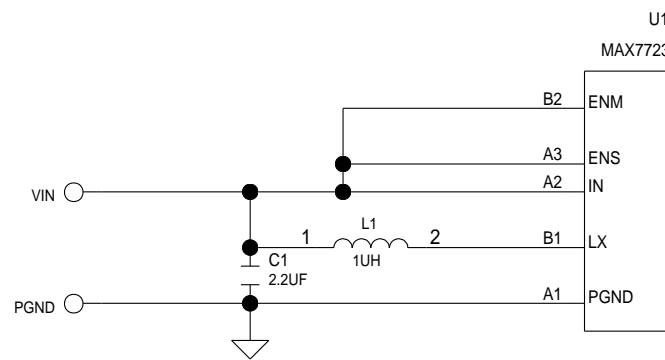

X-ON Electronics

Largest Supplier of Electrical and Electronic Components

Click to view similar products for [Power Management IC Development Tools](#) category:

Click to view products by [Maxim](#) manufacturer:

Other Similar products are found below :

[EVB-EP5348UI](#) [MIC23451-AAAYFL EV](#) [MIC5281YMME EV](#) [124352-HMC860LP3E](#) [DA9063-EVAL](#) [ADP122-3.3-EVALZ](#) [ADP130-0.8-EVALZ](#) [ADP130-1.8-EVALZ](#) [ADP1740-1.5-EVALZ](#) [ADP1870-0.3-EVALZ](#) [ADP1874-0.3-EVALZ](#) [ADP199CB-EVALZ](#) [ADP2102-1.25-EVALZ](#) [ADP2102-1.875EVALZ](#) [ADP2102-1.8-EVALZ](#) [ADP2102-2-EVALZ](#) [ADP2102-3-EVALZ](#) [ADP2102-4-EVALZ](#) [AS3606-DB](#) [BQ25010EVM](#) [BQ3055EVM](#) [ISLUSBI2CKIT1Z](#) [LP38512TS-1.8EV](#) [EVAL-ADM1186-1MBZ](#) [EVAL-ADM1186-2MBZ](#) [ADP122UJZ-REDYKIT](#) [ADP166Z-REDYKIT](#) [ADP170-1.8-EVALZ](#) [ADP171-EVALZ](#) [ADP1853-EVALZ](#) [ADP1873-0.3-EVALZ](#) [ADP198CP-EVALZ](#) [ADP2102-1.0-EVALZ](#) [ADP2102-1-EVALZ](#) [ADP2107-1.8-EVALZ](#) [ADP5020CP-EVALZ](#) [CC-ACC-DBMX-51](#) [ATPL230A-EK](#) [MIC23250-S4YMT EV](#) [MIC26603YJL EV](#) [MIC33050-SYHL EV](#) [TPS60100EVM-131](#) [TPS65010EVM-230](#) [TPS71933-28EVM-213](#) [TPS72728YFFEVM-407](#) [TPS79318YEQEVM](#) [UCC28810EVM-002](#) [XILINXPWR-083](#) [LMR22007YMINI-EVM](#) [LP38501ATJ-EV](#)