

Click [here](#) for production status of specific part numbers.

MAX77654 Evaluation Kit

Evaluates: MAX77654

General Description

The MAX77654 evaluation kit (EV kit) allows for easy experimentation with various MAX77654 features. This includes the SIMO buck-boost regulator, linear regulators, analog multiplexer, smart battery charger, on/off controller, and I²C interface.

Windows®-based software provides a user-friendly graphical user interface (GUI) as well as a detailed register-based interface to exercise the features of the MAX77654.

[Ordering Information](#) appears at end of data sheet.

Benefits and Features

- Easy to Use
- GUI Drives I²C Interface
- On-Board Thermistor
- GPIO LEDs
- Assembled and Fully Tested
- On-Board Electronic Loads
 - Steady-State, Transient, and Random Modes
- Demonstrates End-to-End Analog Multiplexer Implementation
- On-Board ADC
- Evaluates Both Push-Button and Slide-Switch On-Key Options

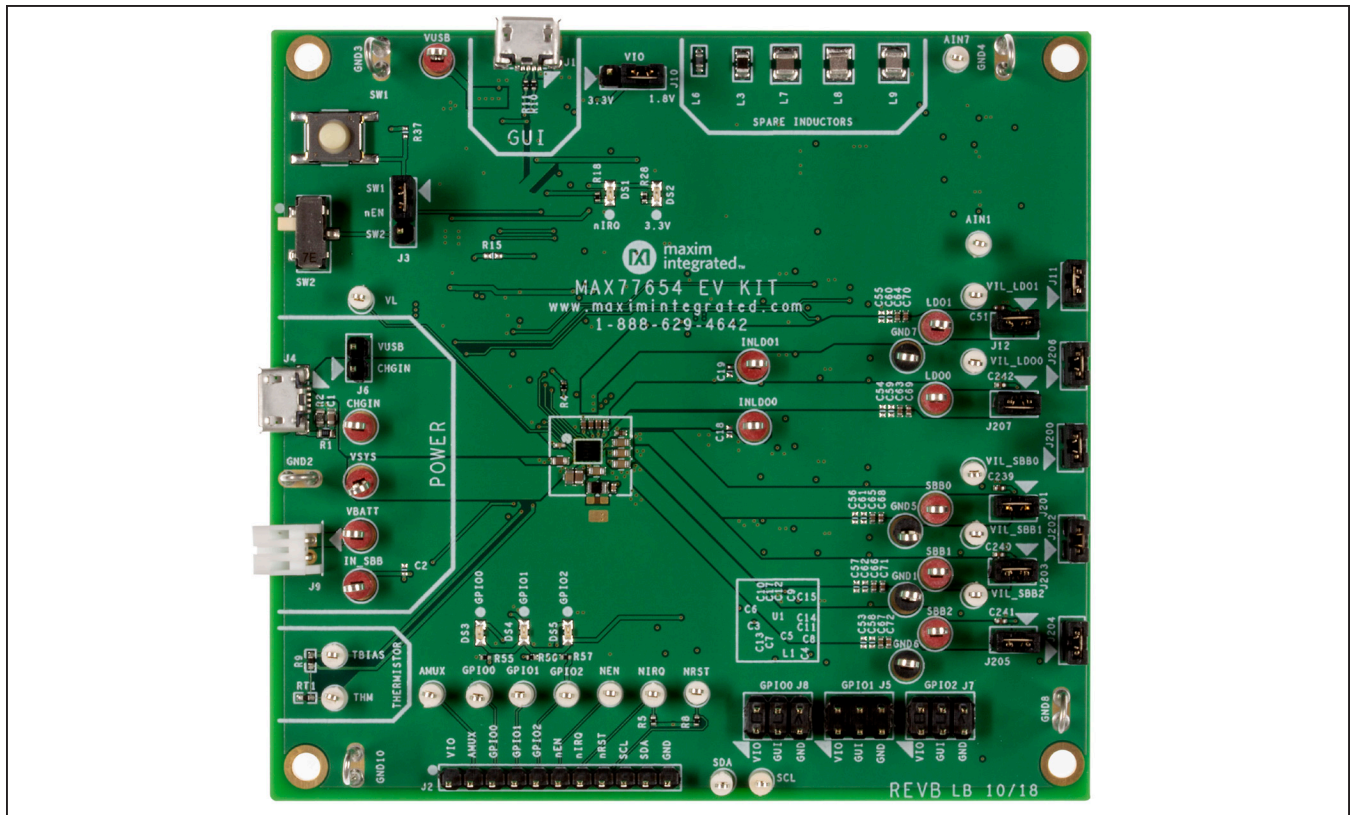

Figure 1. MAX77654 EV Kit Photo

Windows is a registered trademark and registered service mark of Microsoft Corporation.



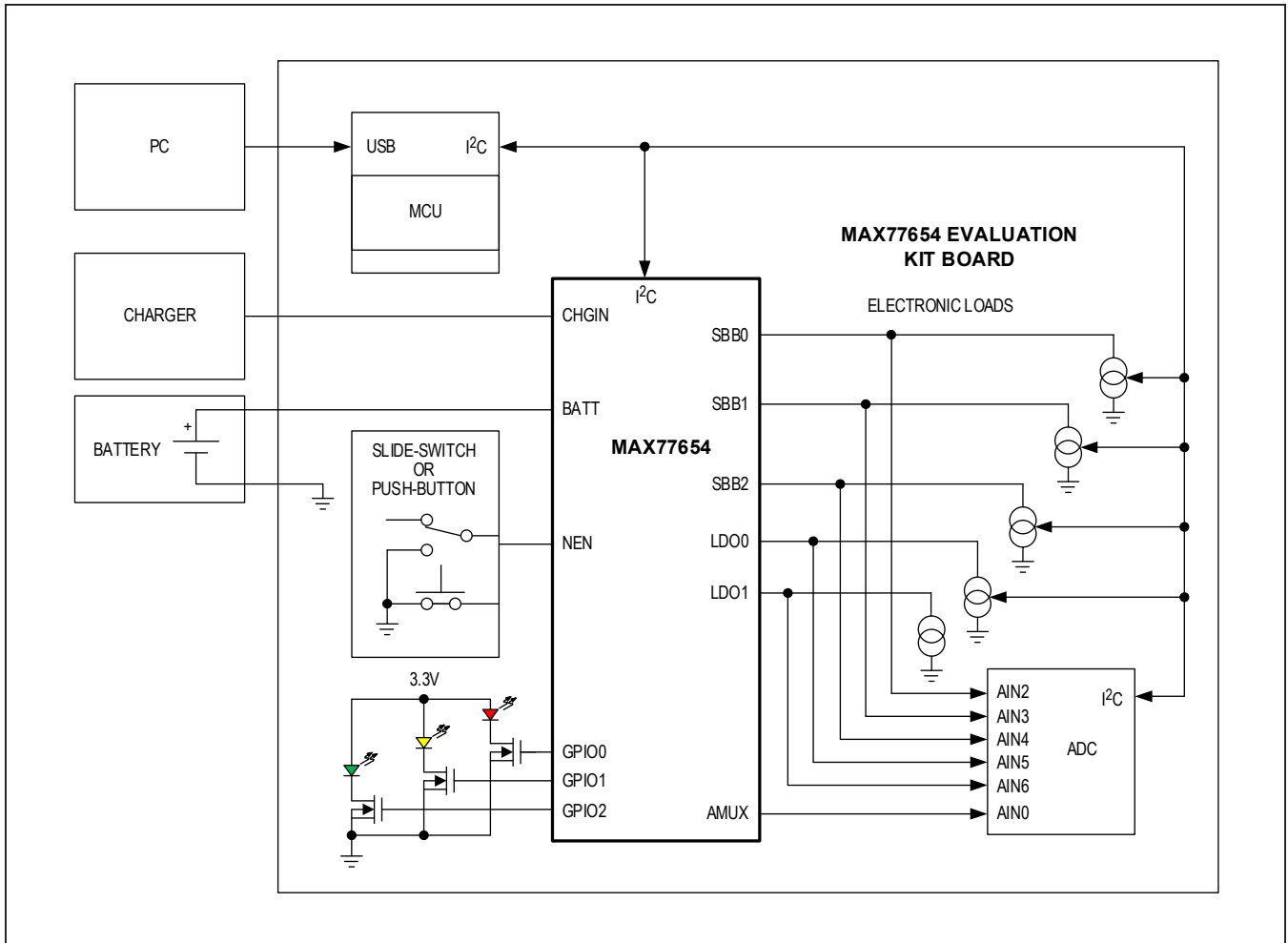

Figure 2. EV Kit Simple Block Diagram

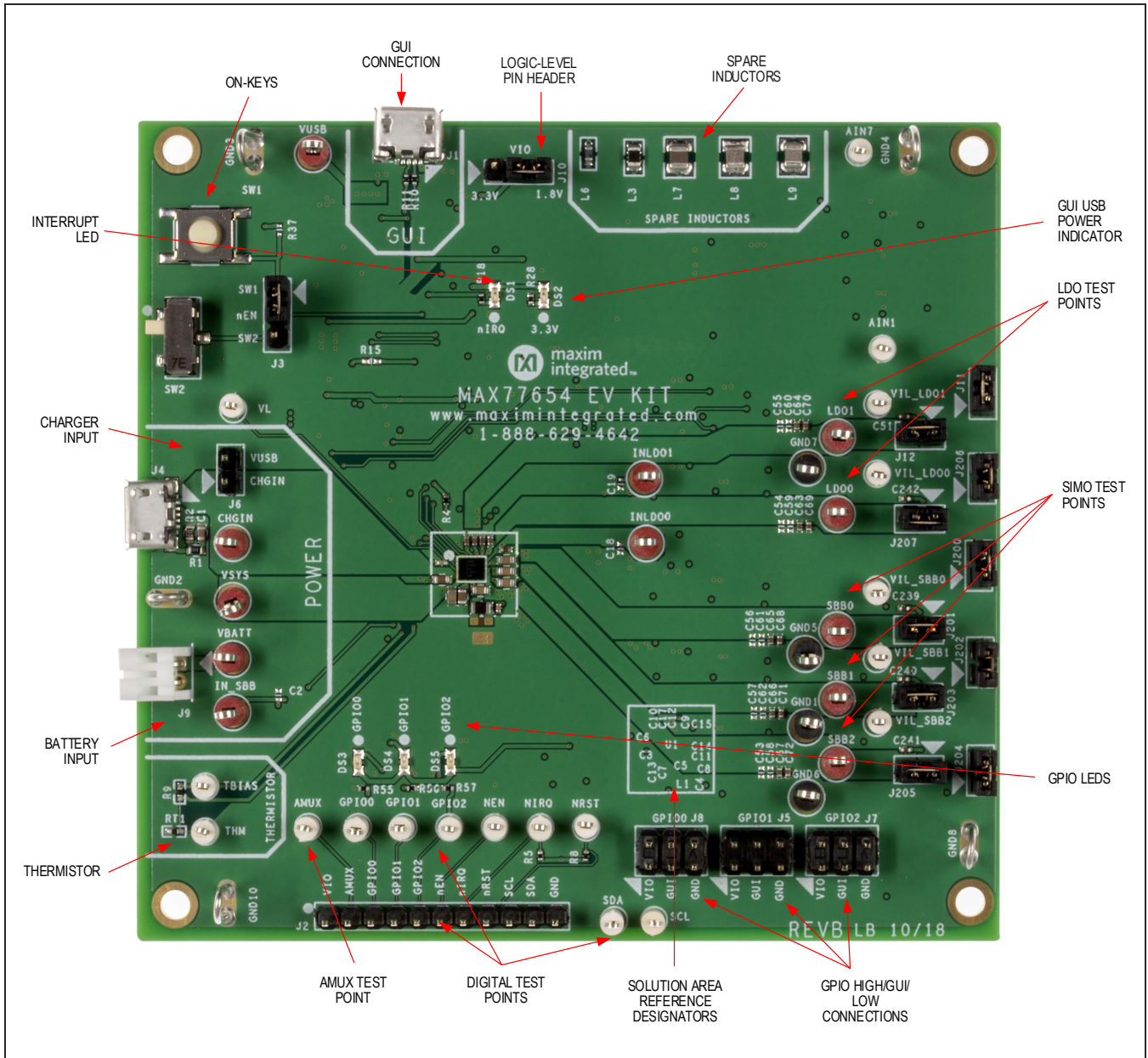

Figure 3. MAX77654 EV Kit Top View

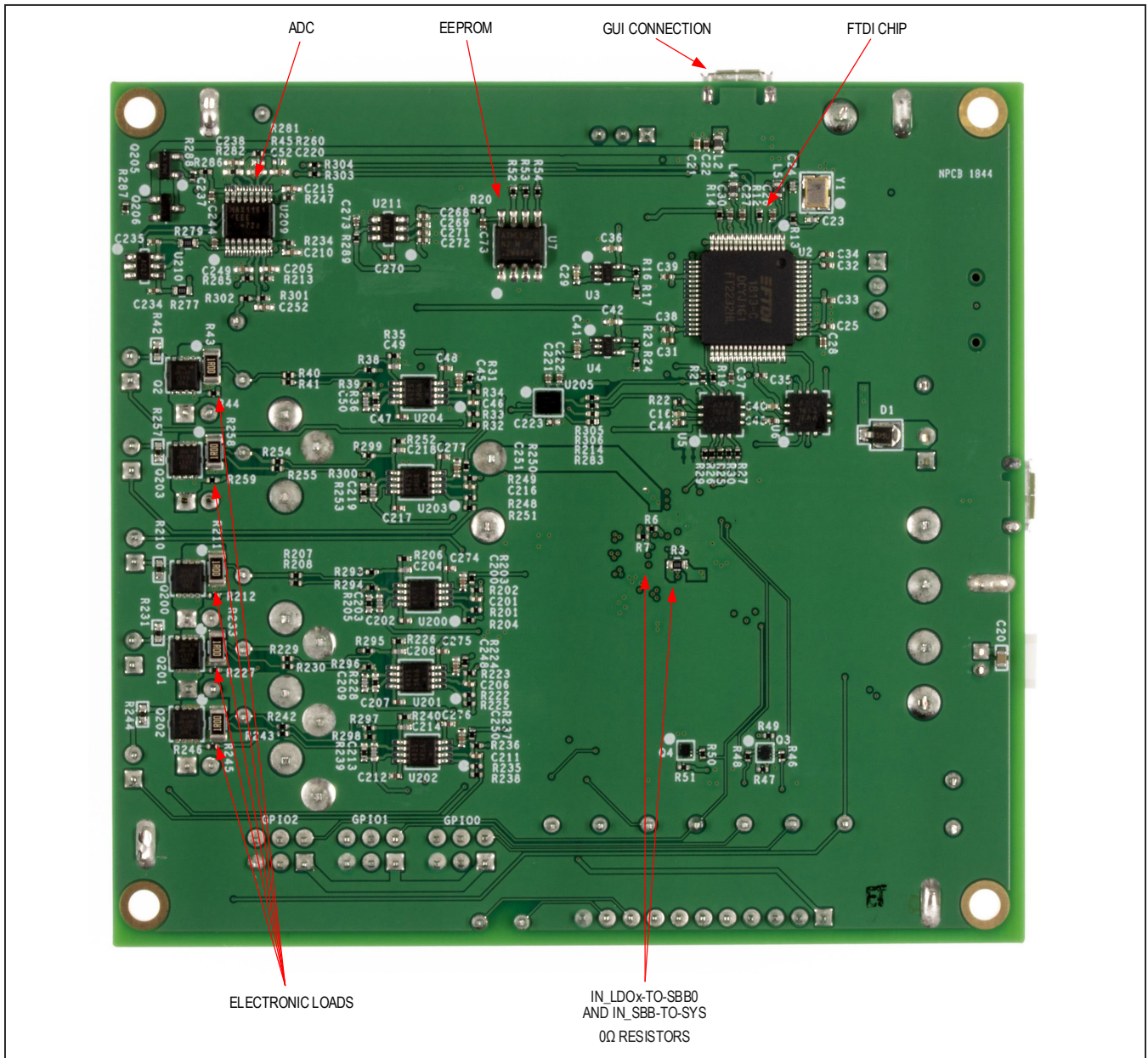

Figure 4. MAX77654 EV Kit Bottom View

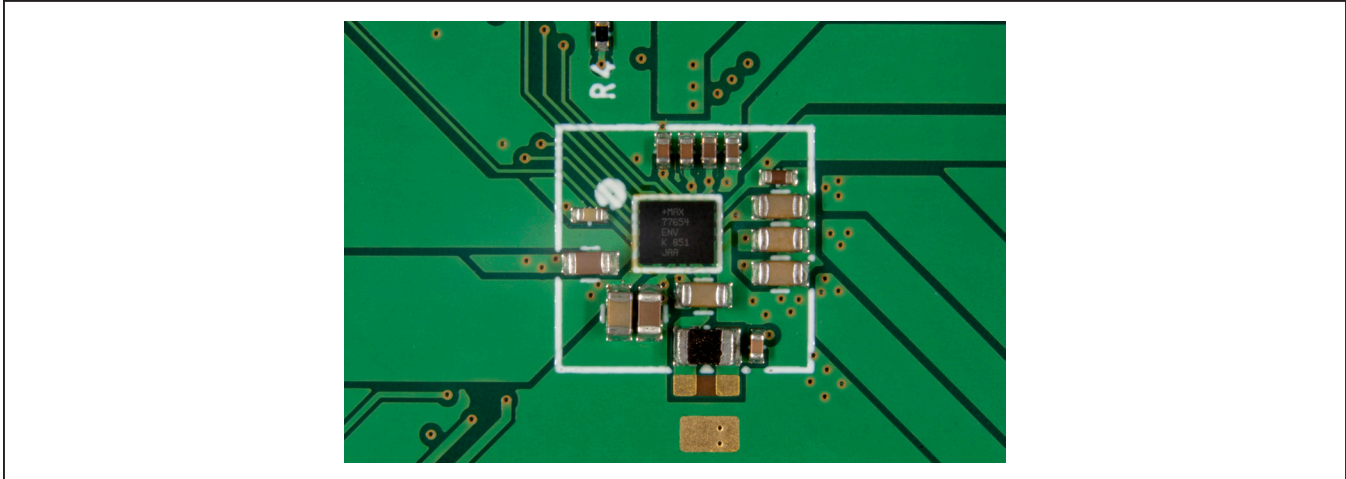

Figure 5. MAX77654 EV Kit Solution Area

MAX77654 EV Kit Files

FILE	DESCRIPTION
MAX77654_SOLDERDOWN_REVC_BOM_2019-06-10.xlsx	BOM
MAX77654_SOLDERDOWN_EVKIT_REVC_SCH_2019-06-10.pdf	Schematic
MAX77654_SOLDERDOWN_EVKIT_REVC_PCB_2019-05-16.pdf	Layout

Quick Start

Follow this procedure to familiarize yourself with the EV kit.

Note: In the following sections, software-related items are identified by bolding. Text in **bold** refers to items directly from the EV kit software. Text in **bold and underlined** refers to items from the Windows operating system.

Required Equipment

- MAX77654 EV kit
- MAX77654 EV kit GUI
- Windows-based PC
- Power supply
- Ammeter
- DVM
- Micro-USB cable

Procedure

- 1) Install the GUI software. Visit the product web-page at <https://www.maximintegrated.com/max-77654evkit> and navigate to Design Resources to download the latest version of the EV kit software.

- 2) Save the EV kit software to a temporary folder and extract the files from the ZIP file.
- 3) Install EV kit shunts according to [Table 1](#).
- 4) Connect a Micro-B USB cable between the EV kit USB port labeled “GUI” and your Windows-based PC.
- 5) Apply a 3.7V supply (set for 100mA current limit) through an ammeter (set for 10mA range) across the VBATT and GND2 terminals of the EV kit. Turn the supply on.
- 6) Open the GUI and select **Device**→**Connect** in the upper-left corner. Wait for a **CONNECTED_DEVICE_LIST** window to pop up, and then press the **Connect** button.
- 7) Press the on-key (SW1).
- 8) On the **ADC/AMUX** tab of the GUI, click the **Read** buttons next to VSBB0, VSBB1, VSBB2, VLDO0, and VLDO1. For the MAX77654M, 1.8V, 1.1V, 3.3V, 1.6V, and 1.8V should appear, respectively ([Figure 6](#)).
- 9) Confirm with the ammeter that the quiescent current is approximately 48µA. Then, in the **Global Resources** tab on the GUI, set the Main Bias Low-Power Mode bit to ‘1’ and click the **Write** button. Now, confirm that the quiescent current is approximately 9µA.

This concludes the Quick Start procedure. Users are encouraged to explore the device and its register settings with the GUI. For guidance on configuring the charger and the GPIOs, see the [Charger Quick Start](#) and [GPIO Quick](#)

[Start](#) sections. During general device evaluation, set the ammeter range to greater than or equal to 1A to minimize the impact of its series resistance.

For more information on the GUI, see the [Software](#) section.

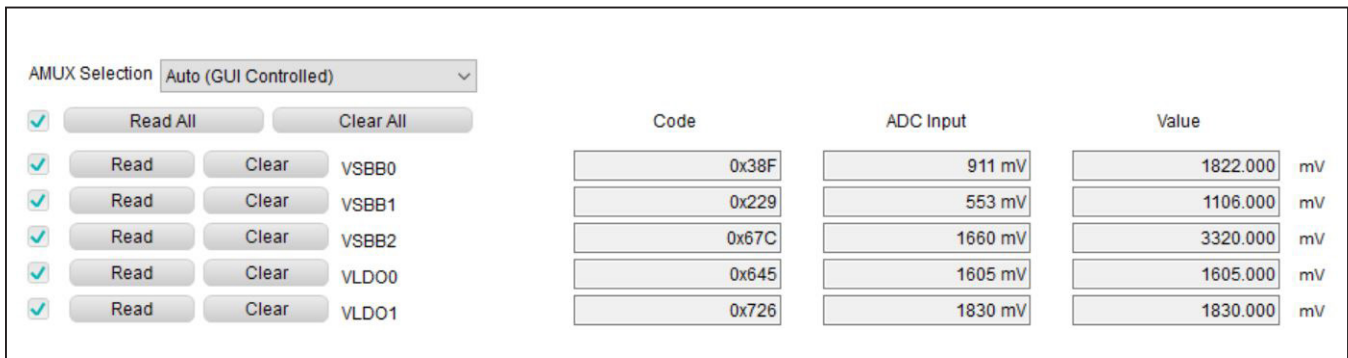

Figure 6. Quick Start: Regulator Check with the ADC

Table 1. Default Shunt Positions and Jumper Descriptions

REFERENCE DESIGNATOR	DEFAULT POSITION	FUNCTION
J3	1-2	1-2: Connects nEN to SW1 (Push-button). 2-3: Connects nEN to SW2 (Slide-switch).
J6	Open	1-2: Connects GUI VUSB to MAX77654 CHGIN. Install this jumper to power MAX77654 from the GUI USB.
J10	2-3	1-2: Connects VIO to 3.3V. 2-3: Connects VIO to 1.8V
J8	3-4	1-2: Connects GPIO0 to VIO. 3-4: Connects GPIO0 to GUI GPIO0 (Refer to the GPIO Quick Start section for more details). 5-6: Connects GPIO0 to ground.
J5	3-4	1-2: Connects GPIO1 to VIO. 3-4: Connects GPIO1 to GUI GPIO0 (Refer to the GPIO Quick Start section for more details). 5-6: Connects GPIO1 to ground.
J7	3-4	1-2: Connects GPIO2 to VIO. 3-4: Connects GPIO2 to GUI GPIO0 (Refer to the GPIO Quick Start section for more details). 5-6: Connects GPIO2 to ground.
J201	1-2	1-2: Connects SBB0 to the onboard electronic load and ADC.
J203	1-2	1-2: Connects SBB1 to the onboard electronic load and ADC.
J205	1-2	1-2: Connects SBB2 to the onboard electronic load and ADC.
J207	1-2	1-2: Connects LDO0 to the onboard electronic load and ADC.
J12	1-2	1-2: Connects LDO1 to the onboard electronic load and ADC.
J200	1-2	1-2: Connects the gate of the Q200 load FET to the U200 amplifier.
J202	1-2	1-2: Connects the gate of the Q201 load FET to the U201 amplifier.
J204	1-2	1-2: Connects the gate of the Q202 load FET to the U202 amplifier.
J206	1-2	1-2: Connects the gate of the Q203 load FET to the U203 amplifier.
J11	1-2	1-2: Connects the gate of the Q2 load FET to the U204 amplifier.

Charger Quick Start

The **Charger** tab on the GUI has many settings to toggle depending on application requirements; however, for a quick start, follow the procedure below:

- 1) Determine the capacity of the battery to identify a safe charge current. Maxim recommends charging at 0.75C (e.g., charge a 40mAh battery with 30mA charge current). Consult the battery manufacturer’s data sheet carefully to determine safe charging parameters.
- 2) In Charger Configuration E/F, move the Fast-Charge Current (IFAST_CHG) slider to the desired charge current setting, and click the **Write** button.
- 3) In Charger Configuration G/H, move the Fast-Charge Voltage (VFAST_CHG) slider to the desired charge voltage setting, and click the **Write** button.
- 4) Make sure there is a 5V charge source connected to the EV kit. Then, enable the charger by setting the switch—in Charger Configuration B—labeled Battery Charger Enable to “1” (Enabled) and click the **Write** button.
- 5) The battery should now be charging at the charge current set from step 2.

For more information on the capabilities of the battery charger, refer to the IC data sheet.

GPIO Quick Start

There are three GPIOs (GPIO0, GPIO1, and GPIO2) that can serve either as standard GPIOs or in their alternate functionalities. Onboard LEDs light up depending on the GPIO state. To get started with the GPIOs, follow the procedure below:

- 1) In the **GPIO** tab of the GUI, set the desired GPIOs Alternate Mode Enable to 0 (Standard GPIO).
- 2) Set the Direction to 0 (Output).
- 3) Set the Driver Type to 1 (Push-Pull). If using 0 (Open-Drain), make sure there is a pullup resistor on the GPIO pin.
- 4) Click the **Write** button.
- 5) Set the Data Output to 1 (Logic High) and click the **Write** button. The onboard LED should light up.
- 6) Now change the Direction to 1 (Input) and click the **Write** button.
- 7) Install the appropriate shunt on J8, J5, or J7 to connect the desired GPIO to the GUI GPIO.
- 8) From the GUI toggle the EV kit GPIO, clicking **Write** after each time. Click **Read** to observe the **GPIO Input Value** update.

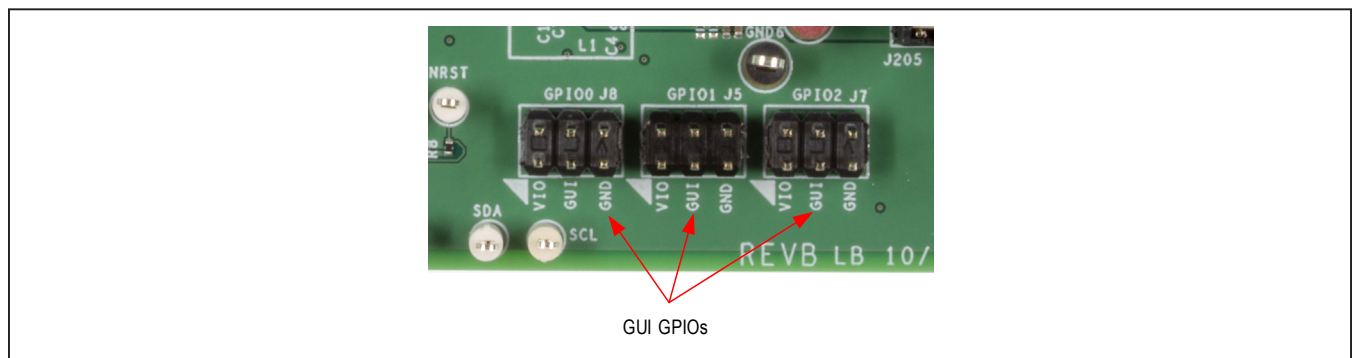

Figure 7. GPIO Headers

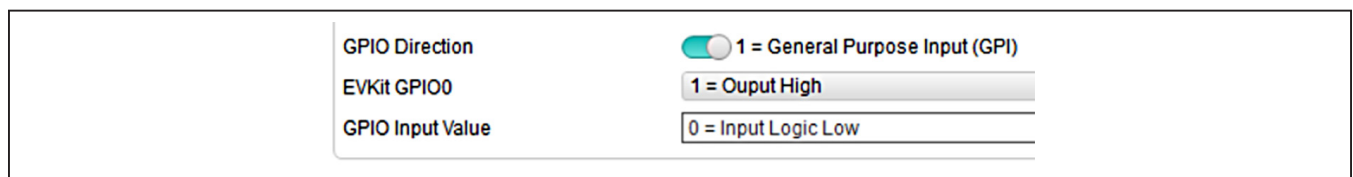

Figure 8. GPIO Input Value Box in GUI

Detailed Description of Hardware (or Software)

On-Key Options

For applications that require the IC to enable with a user-interactable switch, the EV kit comes with two common types: the push-button (momentary) and the slide-switch (persistent). The active-low enable pin (nEN) has an internal pullup resistor. Select which type of switch to use with jumper J3. Refer to the MAX77654 data sheet for more information on configuring the IC for momentary or persistent switches.

Temperature Monitoring

Use the onboard thermistor RT1 to evaluate the charger's response to real ambient temperature. The NTC beta parameter is 3380K. Temperature thresholds corresponding to this NTC beta are listed in [Table 2](#).

The MAX77654 automatically biases the temperature monitoring circuit whenever CHGIN is valid and the thermistor is enabled (THM_EN = 1), or the MUX_SEL[3:0] bitfield configures AMUX to output the TBIAS or THM voltage (MUX_SEL = 0b0111 or 0b1000). Refer to the *Adjustable Thermistor Temperature Monitors* section of the MAX77654 data sheet for more information.

Electronic Load

The EV kit comes with an electronic load allowing the user to evaluate the SIMO and LDO load current capabilities. Onboard circuits set the load current through I²C. J201, J203, J205, J207, and J12 connect the load to the output of the SBB0, SBB1, SBB2, LDO0, and LDO1, respectively. To load SYS, remove J207 and connect pin 1 of the header (marked by a white triangle) to VSYS. To exercise the load transient response, remove J200 (for SBB0), J202 (for SBB1), J204 (for SBB2), J206 (for LDO0), or J11 (for LDO1) and connect a signal generator to the gate of the

Table 2. Trip Thresholds for $\beta = 3380K$ Thermistor

TRIP VOLTAGE (V)	TRIP TEMPERATURES (°C)
1.024	-10
0.976	-5
0.923	0
0.867	5
0.807	10
0.747	15
0.511	35
0.459	40
0.411	45
0.367	50
0.327	55
0.291	60

load MOSFET (pin 2 of the respective header). Drive the gate with a signal between 1V (off) and 3V (fully on) to apply transients to the output of the SIMO or LDO. Note that there are 1 Ω sense resistors with test points (called VIL_SBB0, VIL_SBB1, VIL_SBB2, VIL_LDO0, and VIL_LDO1) for a 1:1 conversion of load current to voltage. See the [Software](#) section to learn how to set the load current from the GUI.

On-Board ADC (MAX11614)

An onboard ADC is available to convert the output voltages of SBB0, SBB1, SBB2, and LDO. The AMUX pin of the MAX77654 and test points AIN1 and AIN7 are also measured. The GUI does the appropriate conversions. See the [Software](#) section for how to read these values from the GUI.

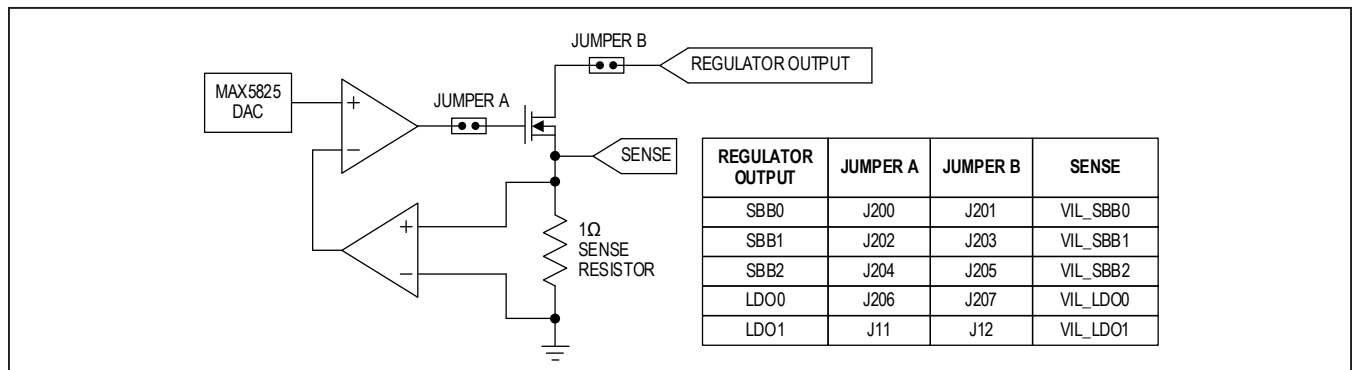

Figure 9. Electronic Load Block Diagram

Software

The graphical-user interface (GUI) software allows for a convenient, quick, and thorough evaluation of the MAX77654.

The GUI has individual tabs for each functional block of the device (global resources, interrupts/status, watchdog, GPIO, charger, SIMO, LDO) and two additional tabs for controlling EV kit hardware (load control and ADC/AMUX). In addition, the FPS Configuration tab contains a plot of the power-up and power-down sequences. See [Figure 10](#) for a screenshot of the GUI upon opening.

Installation

Visit the product webpage at www.maximintegrated.com/max77654evkit and navigate to Design Resources to download the latest version of the EV kit software. Save the EV kit software to a temporary folder and decompress the ZIP file.

Windows Drivers

Upon connection of a Micro-USB cable between your PC and the EV kit for the first time, wait a few minutes for Windows to automatically install drivers.

Graphical User Interface Details (GUI)

The GUI drives I²C communication with the EV kit. Every control in the GUI (excluding the **Load Control** and **ADC/AMUX** tabs) corresponds directly to a register within the MAX77654. Hover your cursor over control names for a description of that register. Refer to the IC data sheet for the complete register map.

Load Control Tab

The **Load Control** tab contains controls for load currents on the regulator outputs. The GUI is capable of setting steady-state, transient, and random load currents. To set a load current, use the slider bar or text field to input a value (mA) and check the **Enable** box. Shuffle through the modes to exercise different load conditions.

The offset and gain values are set by Maxim and do not need to be altered.

ADC/AMUX Tab

This tab allows users to convert important voltage and current signals to digital readings. To read a signal, click the **Read** button and examine the **Interpreted Value** column.

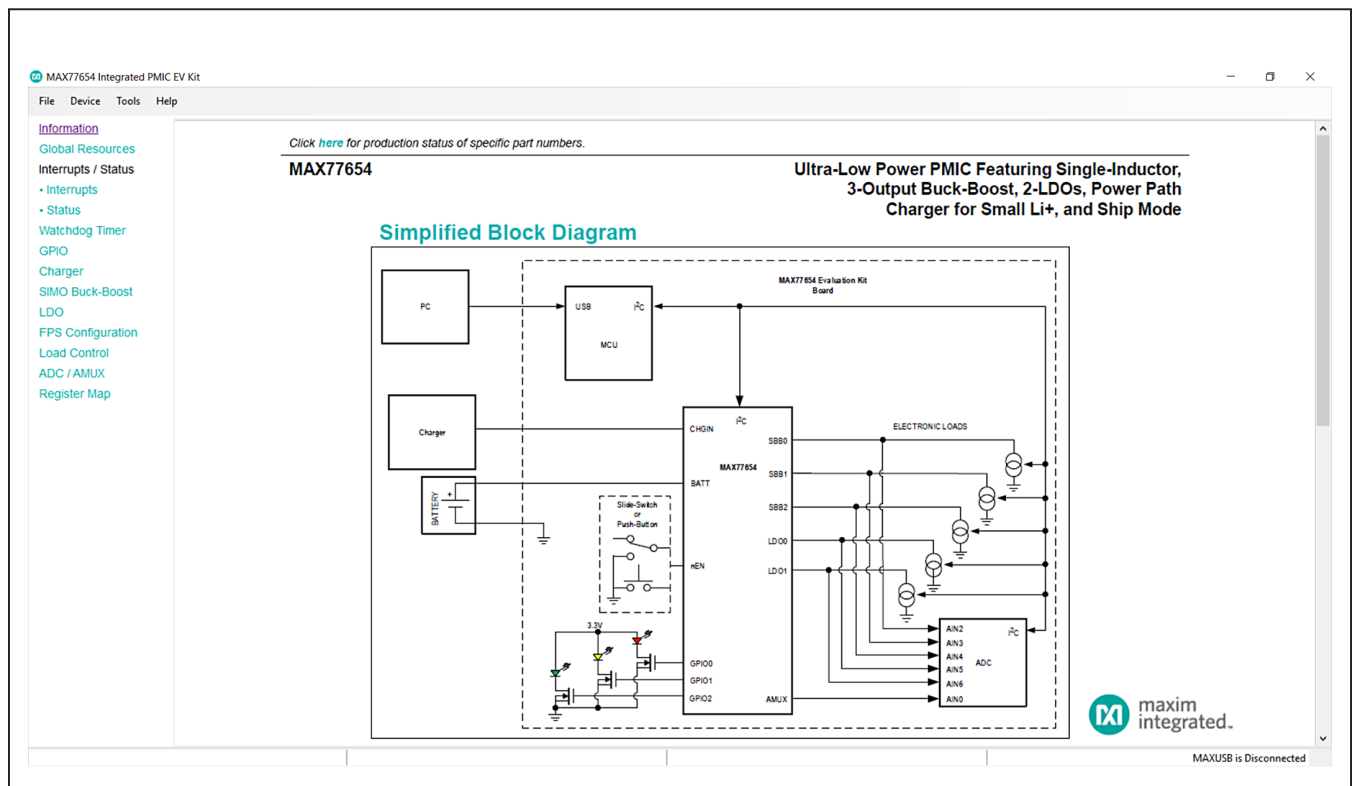

Figure 10. MAX77654 EV Kit GUI

Ordering Information

PART	IC	TYPE
MAX77654EVKIT#	MAX77654MENV+	EV Kit

#Denotes a RoHS-compliant device that may include lead(Pb) that is exempt under the RoHS requirements.

MAX77654 EV Kit Bill of Materials

ITEM	REF_DES	DNI/DNP	QTY	MFG PART #	MANUFACTURER	VALUE	DESCRIPTION
1	AIN1, AIN7, AMUX, GPIO0-GPIO2, I_LDO0, I_LDO1, I_SBB0-I_SBB2, NEN, NIRO, NRST, SCL, SDA, TBIAS, THM, VL	—	19	5002	KEystone	N/A	TEST POINT; PIN DIA = 0.1IN; TOTAL LENGTH = 0.3IN; BOARD HOLE = 0.04IN; WHITE; PHOSPHOR BRONZE WIRE SILVER;
2	C1	—	1	GRM188R71E474KA12; GCM188R71E474KA64	MURATA;MURATA	0.47µF	CAPACITOR; SMT (0603); CERAMIC CHIP; 0.47µF; 25V; TOL = 10%; MODEL = GRM SERIES; TG = -55°C TO +125°C; TC = X7R
3	C3, C7	—	2	C1608X5R1E475K080AC; GRM188R61E475KE11	TDK;MURATA	4.7µF	CAPACITOR; SMT (0603); CERAMIC CHIP; 4.7µF; 25V; TOL = 10%; TG = -55°C TO +85°C; TC = X5R
4	C4	—	1	GRM033R71C332KA88	MURATA	3300PF	CAP; SMT (0201); 3300PF; 10%; 16V; X7R; CERAMIC CHIP
5	C5, C8, C11, C13, C14, C20	—	6	C1608X5R1A226M080AC; GRM188R61A226ME15	TDK;MURATA	22µF	CAPACITOR; SMT (0603); CERAMIC CHIP; 22µF; 10V; TOL = 20%; TG = -55°C TO +85°C; TC = X5R
6	C6, C9, C10, C16, C17, C29, C36, C40-C42, C51, C239-C242, C269-C271	—	18	C0402C105K8PAC; CC0402KRX5R6BB105	KEMET;YAGEO	1µF	CAPACITOR; SMT (0402); CERAMIC CHIP; 1µF; 10V; TOL = 10%; TG = -55°C TO +85°C; TC = X5R
7	C12, C15	—	2	GRM155R61C225KE44	MURATA	2.2µF	CAPACITOR; SMT (0402); CERAMIC CHIP; 2.2µF; 16V; TOL = 10%; TG = -55°C TO +85°C; TC = X5R
8	C21, C28, C31	—	3	C1005X5R1A475K050	TDK	4.7µF	CAPACITOR; SMT (0402); CERAMIC CHIP; 4.7µF; 10V; TOL = 10%; TG = -55°C TO +85°C; TC = X5R
9	C22, C25-C27, C30, C32-C35, C37-C39, C43, C44, C47, C48, C63-C67, C73, C202, C207, C212, C217, C221-C223, C234, C235, C237, C244, C268, C272-C277	—	40	GRM155R71E104KE14; C1005X7R1E104K050BB; TMK105B7104KVH; CGJ2B3X7R1E104K050BB	MURATA;TDK; TAIYO YUDEN;TDK	0.1µF	CAPACITOR; SMT (0402); CERAMIC CHIP; 0.1µF; 25V; TOL = 10%; MODEL = GRM SERIES; TG = -55°C TO +125°C; TC = X7R
10	C23, C24	—	2	GRM0335C1H270JA01	MURATA	27PF	CAP; SMT (0201); 27PF; 5%; 50V; C0G; CERAMIC CHIP
11	C45, C52, C200, C205, C210, C215, C220, C238, C248-C252	—	13	C0402C472K5RAC; GRM155R71H472KA01; C1005X7R1H472K050BA	KEMET; MURATA;TDK	4700PF	CAPACITOR; SMT (0402); CERAMIC CHIP; 4700PF; 50V; TOL = 10%; TG = -55°C TO +125°C; TC = X7R-
12	C46, C201, C206, C211, C216	—	5	C0402H102J5GAC	KEMET	1000PF	CAPACITOR; SMT (0402); CERAMIC CHIP; 1000PF; 50V; TOL = 5%; MODEL = HT SERIES; TG = -55°C TO +200°C; TC = C0G
13	C49, C50, C203, C204, C208, C209, C213, C214, C218, C219	—	10	C0402C180J5GAC; GRM1555C1H180JA01; C1005C0G1H180J050BA	KEMET; MURATA;TDK	18PF	CAPACITOR; SMT (0402); CERAMIC CHIP; 18PF; 50V; TOL = 5%; TG = -55°C TO +125°C; TC = C0G
14	C68-C72	—	5	CL05B103KP5NNN	SAMSUNG ELECTRONICS	0.01µF	CAPACITOR; SMT (0402); CERAMIC; 0.01UF; 10V; TOL = 10%; TG = -55°C TO +125°C; TC = X7R
15	CHGIN, INLDO0, INLDO1, IN_SBB, LDO0, LDO1, SBB0-SBB2, VBATT, VSYS, VUSB	—	12	5010	KEystone	N/A	TEST POINT; PIN DIA = 0.125IN; TOTAL LENGTH = 0.445IN; BOARD HOLE = 0.063IN; RED; PHOSPHOR BRONZE WIRE SIL;
16	D1	—	1	B0530W-7-F	DIODES INCORPORATED	B0530W	DIODE; SCH; SMT (SOD-123); PIV = 30V; IF = 0.5A
17	DS1-DS3	—	3	LTST-C190CKT	LITE-ON ELECTRONICS INC.	LTST-C190CKT	DIODE; LED; STANDARD; RED; SMT (0603); PIV = 5.0V; IF=0.04A; -55°C TO +85°C
18	DS4	—	1	LTST-C190YKT	LITE-ON ELECTRONICS INC.	LTST-C190YKT	DIODE; LED; STANDARD; YELLOW; SMT (0603); PIV = 5.0V; IF = 0.02A; -55°C TO +85°C
19	DS5	—	1	LTST-C190GKT	LITE-ON ELECTRONICS INC.	LTST-C190GKT	DIODE; LED; WATER CLEAR GREEN; SMT (0603); VF = 2.1V; IF = 0.03A; -55°C TO +85°C
20	GND1, GND5-GND7	—	4	5011	KEystone	N/A	TEST POINT; PIN DIA = 0.125IN; TOTAL LENGTH = 0.445IN; BOARD HOLE = 0.063IN; BLACK; PHOSPHOR BRONZE WIRE SILVER PLATE FINISH;

MAX77654 EV Kit Bill of Materials (continued)

ITEM	REF_DES	DNI/DNP	QTY	MFG PART #	MANUFACTURER	VALUE	DESCRIPTION
21	GND2-GND4, GND8, GND10	—	5	9020 BUSS	WEICO WIRE	MAXIMPAD	EVK KIT PARTS; MAXIM PAD; WIRE; NATURAL; SOLID; WEICO WIRE; SOFT DRAWN BUS TYPE-S; 20AWG
22	J1, J4	—	2	10118193-0001LF	FCI CONNECT	10118193-0001LF	CONNECTOR; FEMALE; SMT; MICRO USB B TYPE RECEPTACLE; RIGHT ANGLE; 5PINS
23	J2	—	1	PBC11SAAN	SULLINS ELECTRONICS CORP.	PBC11SAAN	CONNECTOR; MALE; THROUGH HOLE; BREAKAWAY; STRAIGHT; 11PINS; -65°C TO +125°C
24	J3	—	1	TSW-103-07-T-S	SAMTEC	TSW-103-07-T-S	CONNECTOR; THROUGH HOLE; TSW SERIES; SINGLE ROW; STRAIGHT; 3PINS
25	J5, J7, J8	—	3	TSW-103-07-L-D	SAMTEC	TSW-103-07-L-D	CONNECTOR; MALE; THROUGH HOLE; THROUGH HOLE 0.025 POST HEADER; STRAIGHT; 6PINS
26	J6, J11, J12, J200-J207	—	11	TSW-102-07-T-S	SAMTEC	TSW-102-07-T-S	CONNECTOR; THROUGH HOLE; TSW SERIES; SINGLE ROW; STRAIGHT; 2PINS; -55°C TO +105°C
27	J9	—	1	S2B-PH-K-S(LF)(SN)	JST MANUFACTURING	S2B-PH-K-S(LF)(SN)	CONNECTOR; MALE; THROUGH HOLE; 2.0MM PITCH; DISCONNECTABLE CRIMP STYLE CONNECTOR; SIDE ENTRY TYPE; RIGHT ANGLE; 2PINS
28	J10	—	1	PEC03SAAN	SULLINS ELECTRONICS CORP.	PEC03SAAN	EVKIT PART-CONNECTOR; MALE; THROUGH HOLE; BREAKAWAY; STRAIGHT; 3PINS; -65°C TO +125°C;
29	L1	—	1	DFE201612E-2R2M	MURATA	2.2µH	INDUCTOR; SMT (0806); WIREWOUND CHIP; 2.2µH; TOL = ±20%; 1.8A
30	L2, L4, L5	—	3	BLM18AG601SN1	MURATA	600	INDUCTOR; SMT (0603); FERRITE-BEAD; 600; TOL = ±; 0.5A
31	L3	—	1	DFE201210S-2R2M = P2	MURATA	2.2µH	EVKIT PART-INDUCTOR; SMT (0805); MAGNETICALLY SHIELDED; 2.2µH; TOL = ±20%; 1.8A
32	L7	—	1	DFE201210U-1R5M = P2	TOKO	1.5µH	INDUCTOR; SMT (0805); METAL ALLOY CHIP; 1.5µH; TOL = ±20%; 1.9A
33	L8	—	1	DFE201612E-1R0M	MURATA	1µH	INDUCTOR; SMT (0806); WIREWOUND CHIP; 1µH; TOL = ±20%; 2.9A
34	L9	—	1	DFE201612E-1R5M	MURATA	1.5µH	INDUCTOR; SMT (0806); METAL; 1.5µH; 20%; 2.30A
35	Q2, Q200-Q203	—	5	IRFHM8337TRPBF	INTERNATIONAL RECTIFIER	IRFHM8337TRPBF	TRAN; HEXFET POWER MOSFET; NCH; PQFN8; PD-(2.8W); I-(18A); V-(30V)
36	Q3, Q4	—	2	DMN2005DLP4K	DIODES INCORPORATED	DMN2005DLP4K	TRAN; DUAL N-CHANNEL ENHANCEMENT MODE MOSFET; NCH; DFN1310-6; PD-(0.4W); I-(0.3A); V-(20V)
37	Q205	—	1	FDN360P	FAIRCHILD SEMICONDUCTOR	FDN360P	TRANSISTOR; MOSFET P-CHANNEL, SUPERSOT-3, PD = 0.5W, ID = -2.0A, VDSS = -30V, VGSS = ±20V
38	Q206	—	1	2N7002;2N7002; 2N7002;2N7002	DIODES INCORPORATED; ST MICRO ELECTRONICS; ON SEMICONDUCTOR; MICRO COMMERCIAL COMPONENTS	2N7002	TRAN; ; NCH; SOT-23; PD-(0.33W); IC-(0.5A); VCEO-(60V); -55°C TO +150°C
39	R1, R3, R277, R279	—	4	CRCW0603000020	VISHAY DALE	0	RESISTOR; 0603; 0Ω; 0%; JUMPER; 0.1W; THICK FILM
40	R2	—	1	ANY	ANY	1M	RESISTOR; 0603; 1M; 1%; 100PPM; 0.10W; THICK FILM; FORMFACTOR
41	R4, R6, R7, R19, R20, R29, R30, R33, R44, R52-R54, R204, R225, R238, R251, R259, R285, R286, R302-R306	—	24	ERJ-2GE0R00	PANASONIC	0	RESISTOR; 0402; 0Ω; 0%; JUMPER; 0.10W; THICK FILM
42	R8, R9, R281, R282, R287, R288	—	6	CRCW040210K0FK; RC0402FR-0710KL	VISHAY DALE; YAGEO PHICOMP	10K	RESISTOR; 0402; 10K; 1%; 100PPM; 0.0625W; THICK FILM
43	R10, R11	—	2	ERJ-2RKf27R0X; RC0402FR-0727RL; CRCW040227R0FK	PANASONIC; YAGEO PHICOMP; VISHAY DALE	27	RESISTOR; 0402; 27Ω; 1%; 100PPM; 0.0625W, THICK FILM
44	R12	—	1	ERJ-2RKf1202	PANASONIC	12K	RESISTOR; 0402; 12KΩ; 1%; 100PPM; 0.1W; THICK FILM
45	R13, R42, R55-R57, R210, R231, R244, R257, R301	—	10	CRCW04021M00FK	VISHAY DALE	1M	RESISTOR; 0402; 1M; 1%; 100PPM; 0.0625W; THICK FILM

MAX77654 EV Kit Bill of Materials (continued)

ITEM	REF_DES	DNI/DNP	QTY	MFG PART #	MANUFACTURER	VALUE	DESCRIPTION
46	R14, R40, R41, R207, R208, R229, R230, R242, R243, R254, R255	—	11	ERJ-2RKF1001	PANASONIC	1K	RESISTOR; 0402; 1KΩ; 1%; 100PPM; 0.10W; THICK FILM
47	R16	—	1	CRCW04024752FK; 9C04021A4752FLHF3; CRCW040247K5FK	VISHAY DALE; YAGEO; VISHAY DALE	47.5K	RESISTOR; 0402; 47.5K; 1%; 100PPM; 0.0625W; THICK FILM
48	R5, R214, R283, R17, R24	—	5	CRCW0402100KFK; RC0402FR-07100KL	VISHAY;YAGEO	100K	RESISTOR; 0402; 100K; 1%; 100PPM; 0.0625W; THICK FILM
49	R18, R47	—	2	CRCW0402150RFK; 9C04021A1500FL	VISHAY DALE; YAGEO	150	RESISTOR; 0402; 150Ω; 1%; 100PPM; 0.0625W; THICK FILM
50	R21, R22	—	2	ERJ-2GEJ472	PANASONIC	4.7K	RESISTOR; 0402; 4.7KΩ; 5%; 200PPM; 0.10W; THICK FILM
51	R23	—	1	CRCW0402169KFK	VISHAY DALE	169K	RESISTOR; 0402; 169KΩ; 1%; 100PPM; 0.063W; THICK FILM
52	R25, R26	—	2	CRCW04022K20FK; RC0402FR-072K2L	VISHAY DALE; YAGEO PHICOMP	2.2K	RESISTOR; 0402; 2.2KΩ; 1%; 100PPM; 0.0625W, THICK FILM
53	R27	—	1	RC0402FR-0722RL	YAGEO PHYCOMP	22	RESISTOR; 0402; 22Ω; 1%; 100PPM; 0.063W; THICK FILM
54	R28	—	1	CRCW0402470RFK	VISHAY DALE	470	RESISTOR; 0402; 470Ω; 1%; 100PPM; 0.0625W, THICK FILM
55	R31, R203, R224, R237, R250	—	5	ERJ-2RKF2002	PANASONIC	20K	RESISTOR; 0402; 20KΩ; 1%; 100PPM; 0.1W; THICK FILM
56	R32, R201, R222, R235, R248, R289	—	6	CRCW0402100RFK; 9C04021A1000FL; RC0402FR-07100RL	VISHAY DALE;PANASONIC; YAGEO PHYCOMP	100	RESISTOR; 0402; 100Ω; 1%; 100PPM; 0.063W; THICK FILM
57	R34, R202, R223, R236, R249	—	5	CRCW0402680RFK; RC0402FR-07680RL	VISHAY DALE;YAGEO PHICOMP	680	RESISTOR; 0402; 680Ω; 1%; 100PPM; 0.0625W, THICK FILM
58	R35, R36, R205, R206, R226, R228, R239, R240, R252, R253	—	10	ERJ-2RKF3301	PANASONIC	3.3K	RESISTOR; 0402; 3.3KΩ; 1%; 100PPM; 0.10W; THICK FILM
59	R38, R293, R295, R297, R299	—	5	ERJ-2RKF4703	PANASONIC	470K	RESISTOR; 0402; 470KΩ; 1%; 100PPM; 0.0625W, THICK FILM
60	R39, R294, R296, R298, R300	—	5	CRCW0402649KFK	VISHAY DALE	649K	RESISTOR; 0402; 649KΩ; 1%; 100PPM; 0.063W; THICK FILM
61	R43, R211, R233, R245, R258	—	5	CSR1206FT1R00	STACKPOLE ELECTRONICS INC.	1	RESISTOR; 1206; 1Ω; 1%; 100PPM; 0.5W; THICK FILM
62	R46, R48, R50	—	3	CRCW04021R00FK	VISHAY DALE	1	RESISTOR; 0402; 1Ω; 1%; 100PPM; 0.0625W, THICK FILM
63	R49, R51	—	2	CRCW0402120RFK; RC0402FR-07120RL	VISHAY DALE; YAGEO	120	RESISTOR; 0402; 120Ω; 1%; ±100PPM; 0.063W; THICK FILM
64	R212, R213, R227, R234, R246, R247	—	6	CRCW0402787KFK	VISHAY DALE	787K	RESISTOR; 0402; 787KΩ; 1%; 100PPM; 0.063W; METAL FILM

MAX77654 EV Kit Bill of Materials (continued)

ITEM	REF_DES	DNI/DNP	QTY	MFG PART #	MANUFACTURER	VALUE	DESCRIPTION
65	RT1	—	1	NCP15XH103F03	MURATA	10K	THERMISTOR; SMT (0402); THICK FILM (NICKEL PLATED); 10K; TOL = ±1%
66	SW1	—	1	EVQ-Q2K03W	PANASONIC	EVQ-Q2K03W	SWITCH; SPST; SMT; 15V; 0.02A; LIGHT TOUCH SWITCH; RCOIL = Ω; RINSULATION = Ω; PANASONIC
67	SW2	—	1	CL-SB-12B-11	NIDEC COPAL ELECTRONICS CORP	CL-SB-12B-11	SWITCH; SPDT; SMT; 12V; 0.2A; CL-SB SERIES; SLIDE SWITCH; RCOIL = 0.05Ω; RINSULATION = 100MΩ
68	U1	—	1	MAX77654MENV+	MAXIM	MAX77654MENV+	EVKIT PART - IC; MAX77654MENV+; WLP30; PACKAGE CODE: N302C2+1; PACKAGE OUTLINE DRAWING: 21-100307
69	U2	—	1	FT2232HL	FUTURE TECHNOLOGY DEVICES INTL LTD.	FT2232HL	IC; MMRY; DUAL HIGH SPEED USB TO MULTIPURPOSE UART/FIFO; LQFP64
70	U3, U4	—	2	MAX8512EXK+	MAXIM	MAX8512EXK	IC, VREG, Ultra-Low-Noise, High PSRR, Adjustable Vout, SC70-5
71	U5, U6	—	2	MAX3395EETC+	MAXIM	MAX3395EETC	IC; TRANS; 15KV ESD-PROTECTED HIGH-DRIVE CURRENT QUAD-LEVEL TRANSLATOR WITH SPEED-UP CIRCUITRY; TQFN12 4X4
72	U7	—	1	AT24CS02-SSHM	MICROCHIP	AT24CS02-SSHM	IC; EPROM; I2C-COMPATIBLE TWO-WIRE SERIAL EEPROM; 150MIL; NSOIC8
73	U200-U204	—	5	MAX44251AUA+	MAXIM	MAX44251AUA+	IC; OPAMP; ULTRA-PRECISION; LOW-NOISE OP AMP; UMAX8
74	U205	—	1	MAX5825AWP+	MAXIM	MAX5825AWP+T	IC; DAC; ULTRA-SMALL; OCTAL CHANNEL; 12-BIT BUFFERED OUTPUT DAC WITH INTERNAL REFERENCE AND I2C INTERFACE; WLP20
75	U209	—	1	MAX11614EEE+	MAXIM	MAX11614EEE+	IC; ADC; LOW-POWER; 8-CHANNEL; I2C; 12-BIT ADC IN ULTRA-SMALL PACKAGE; QSOP16
76	U210	—	1	MAX6071AAUT41+	MAXIM	MAX6071AAUT41+	IC; VREF; LOW NOISE; HIGH-PRECISION SERIES VOLTAGE REFERENCE; SOT23-6
77	U211	—	1	MAX1697UEUT+	MAXIM	MAX1697UEUT+	IC; INV; INVERTING CHARGE PUMP WITH SHUTDOWN; SOT23-6
78	Y1	—	1	7M-12.000MAAJ	TXC CORPORATION	12MHZ	CRYSTAL; SMT; 18PF; 12MHZ; ±30PPM; ±30PPM
79	PCB	—	1	MAX77654	MAXIM	PCB	PCB:MAX77654
80	L6	DNP	0	MLP1608VR47D	TDK	0.47µH	INDUCTOR; SMT (0603); SHIELDED; 0.47µH; TOL = ±0.3nH; 0.8A
81	C2, C18, C19, C53-C62	DNP	0	N/A	N/A	OPEN	CAPACITOR; SMT (0402); OPEN; FORMFACTOR
82	R15, R37, R45, R260	DNP	0	N/A	N/A	OPEN	RESISTOR; 0402; OPEN; FORMFACTOR
TOTAL			338				

NOTE: DNI--> DO NOT INSTALL (PACKOUT); DNP--> DO NOT PROCURE

MAX77654 EV Kit Schematic

Part Number	Configuration	7-bit	8-bit Write	8-bit Read
MAX77654 (PMIC)	ADDR OTP bit set for 0	0x40 0b100 0000	0x80 0b1000 0000	0x81 0b1000 0001
MAX77654 (PMIC)	ADDR OTP bit set for 1	0x48 0b100 1000	0x90 0b1001 0000	0x91 0b1001 0001
MAX77654 (PMIC)	Maxim internal test mode	0x49 0b100 1001	0x92 0b1001 0010	0x93 0b1001 0011
MAX11614 (ADC)	N/A	0x33 0b011 0011	0x66 0b0110 0110	0x67 0b0110 0111
MAX5825 (DAC)	ADDR1=ADDR0=VDDIO	0x1F 0b001 1111	0x3E 0b0011 1110 0x10 * 0b0010 1000	0x3F 0b0011 1111
AT24CS02 (EEPROM)	A0=A1=A2=GND	0x50 ** 0b101 0000	0b1010 0000	0b1010 0001

*MAX5825 ALSO RESPONDS TO AN I2C BROADCAST ADDRESS 0b0010 1000

**AT24CS02 ALSO RESPONDS TO 0b1011 0001 FOR READING THE SERIAL NUMBER

MAX77654 EV Kit Schematic (continued)

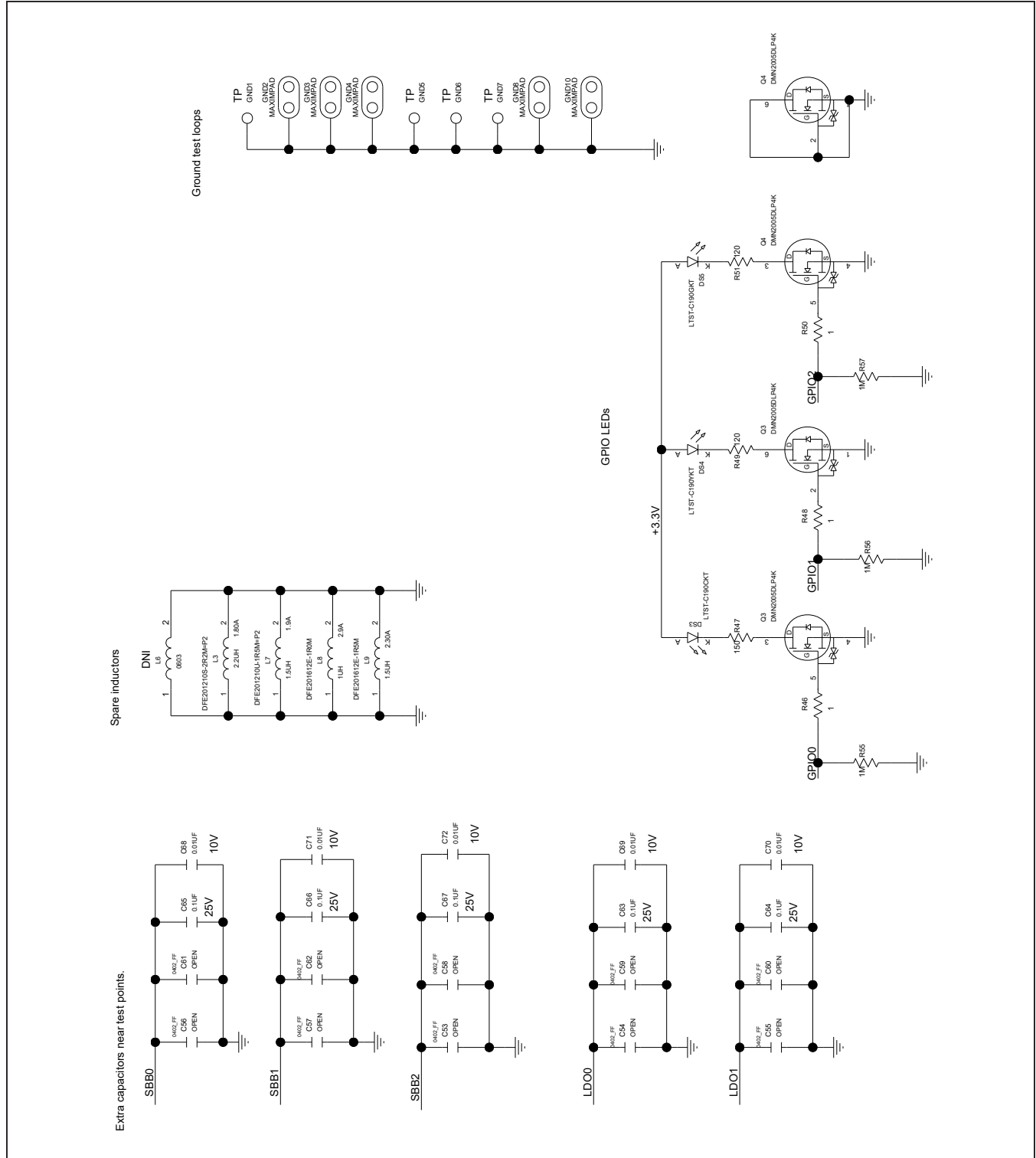

MAX77654 EV Kit Schematic (continued)

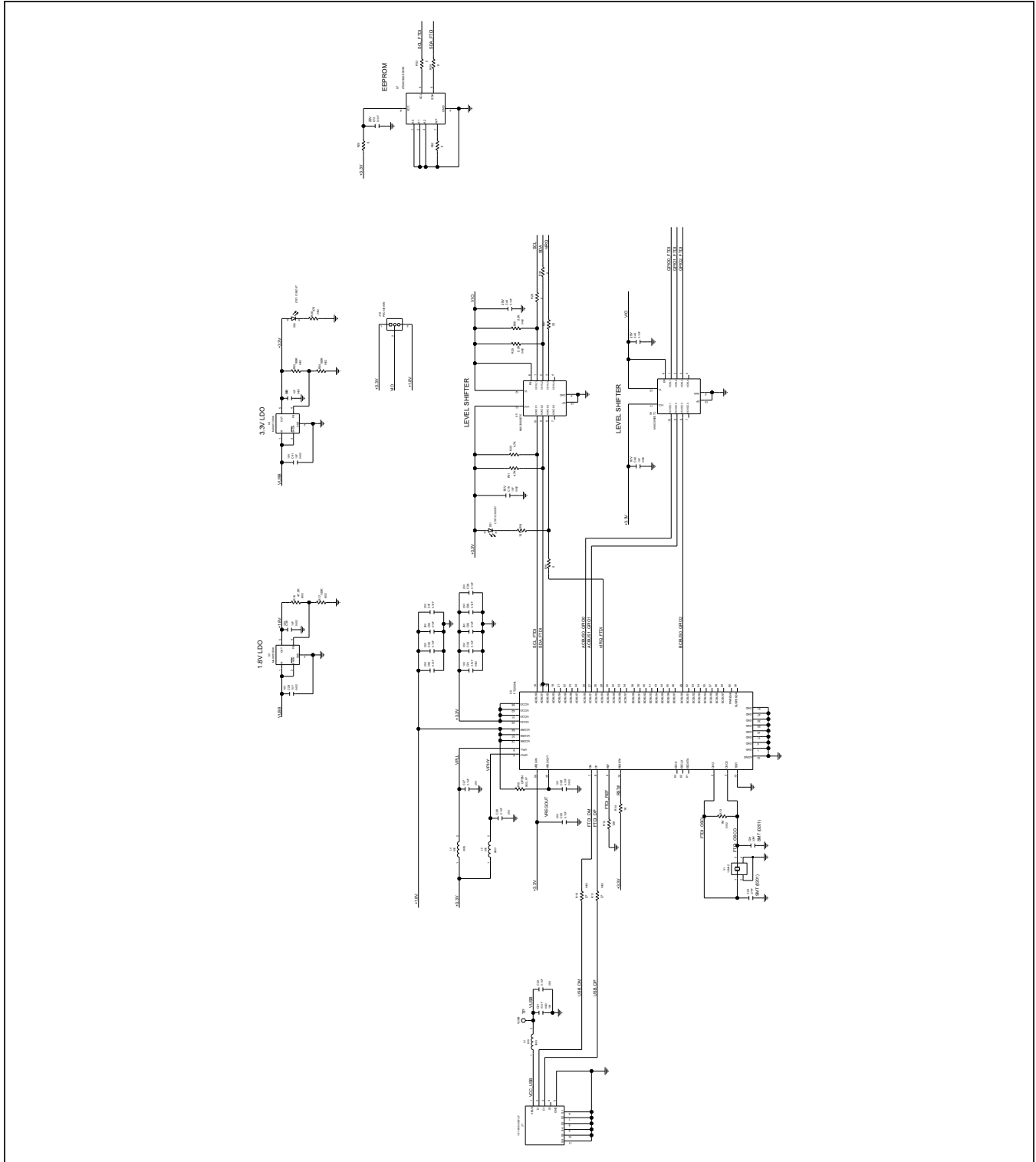

MAX77654 EV Kit PCB Layouts

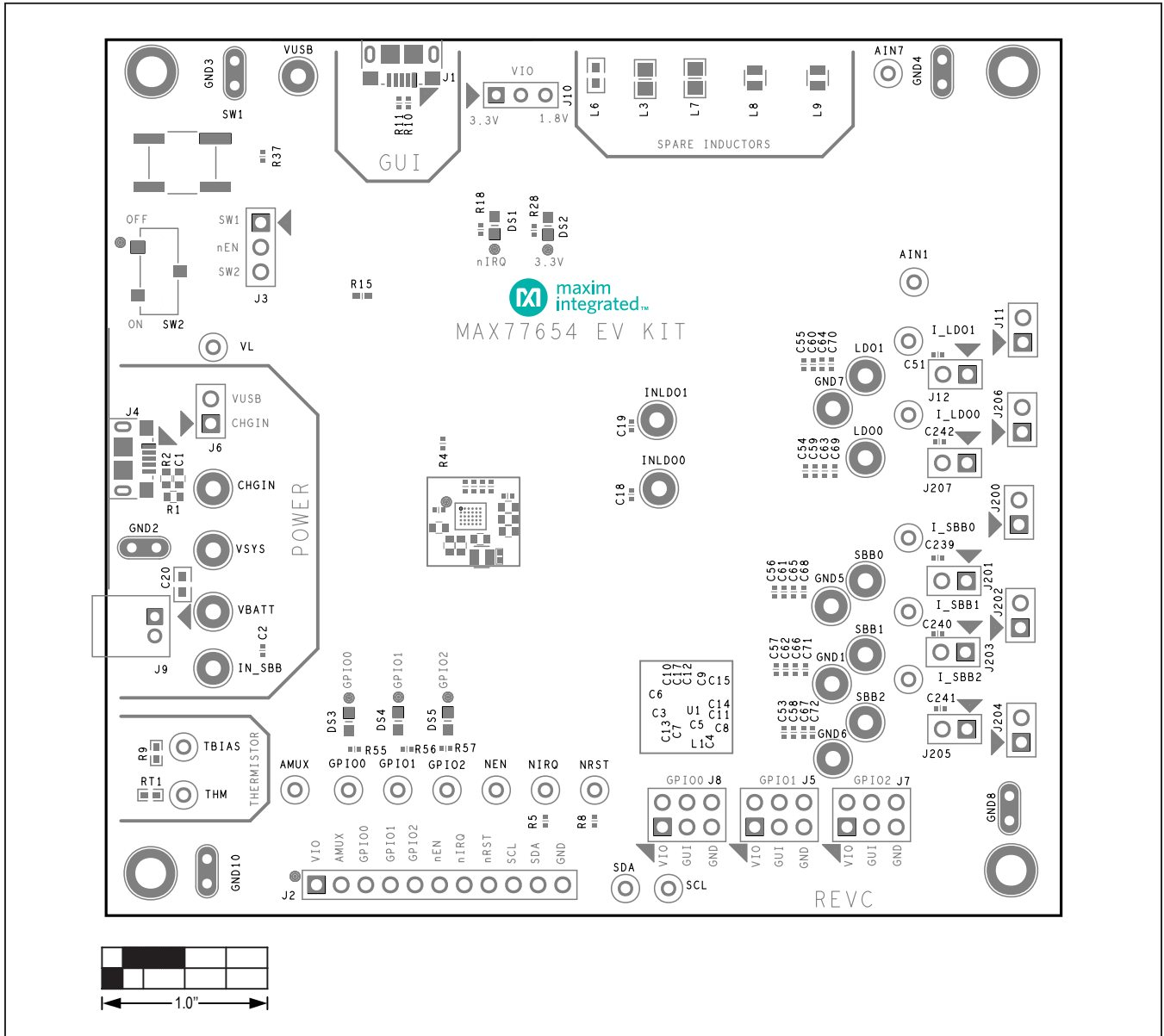

MAX77654 EV Kit Component Placement Guide—Top Silkscreen

MAX77654 EV Kit PCB Layouts (continued)

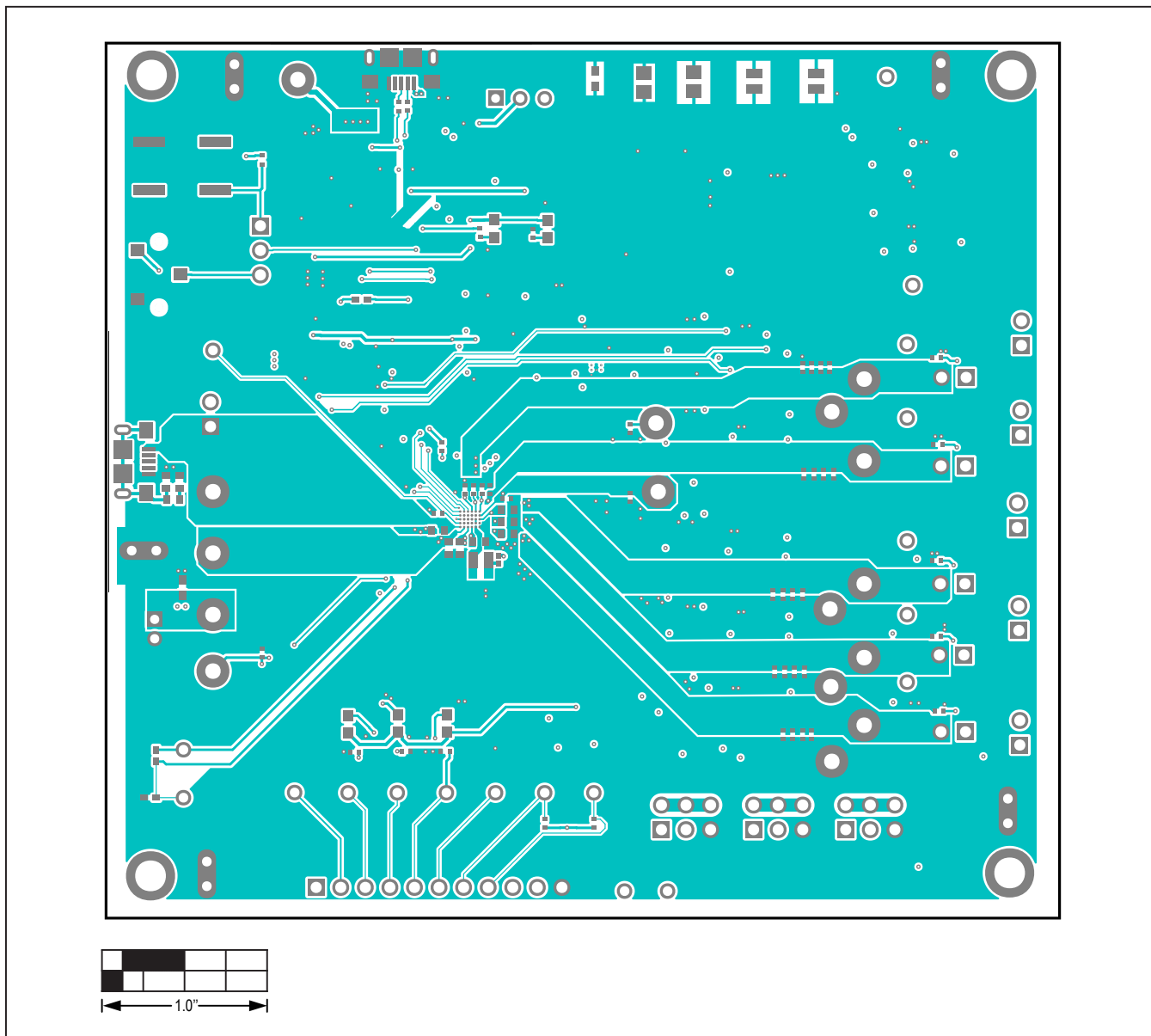

MAX77654 EV Kit PCB Layout—Top Layer

MAX77654 EV Kit PCB Layouts (continued)

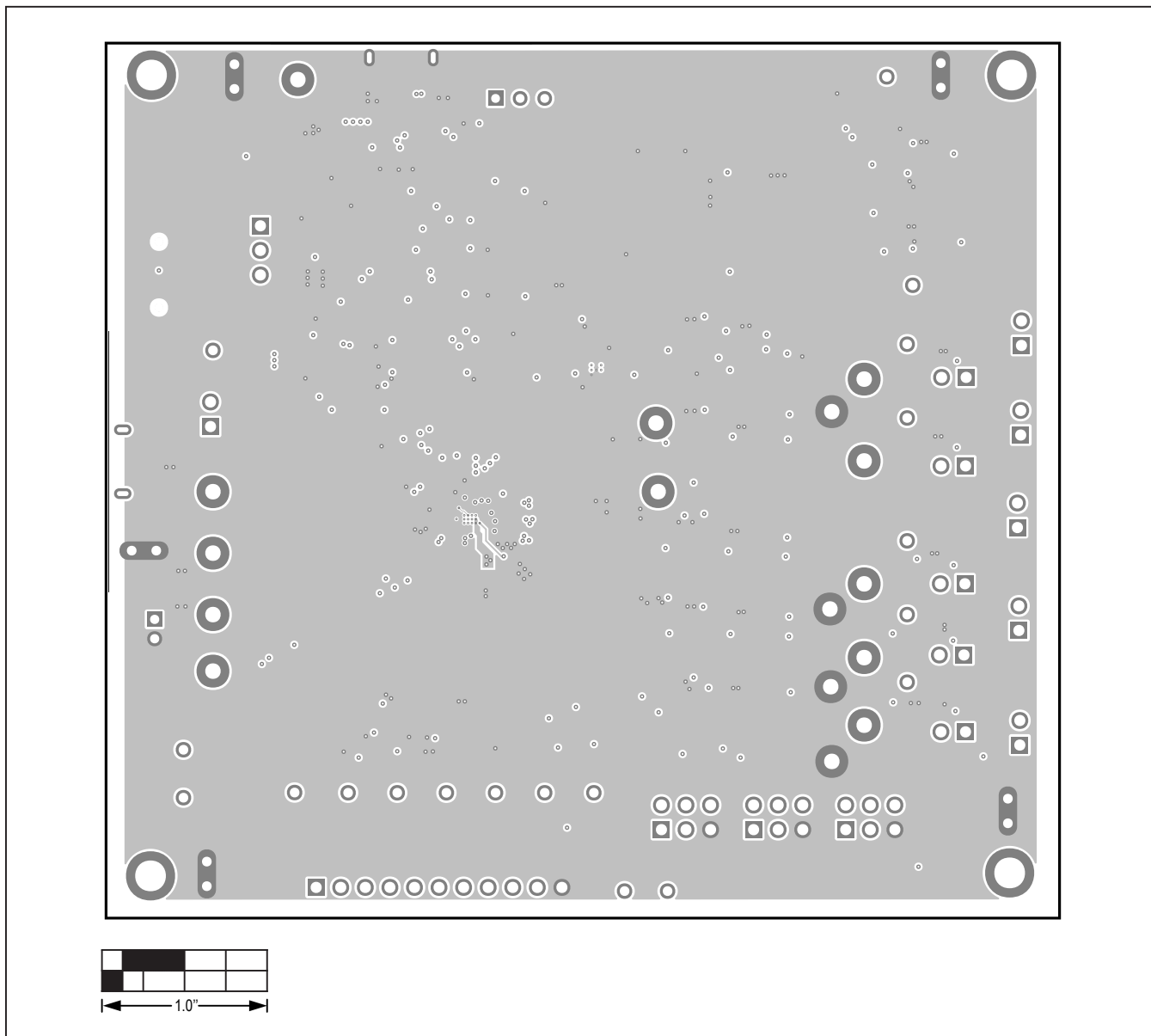

MAX77654 EV Kit PCB Layout—Internal Layer 2

MAX77654 EV Kit PCB Layouts (continued)

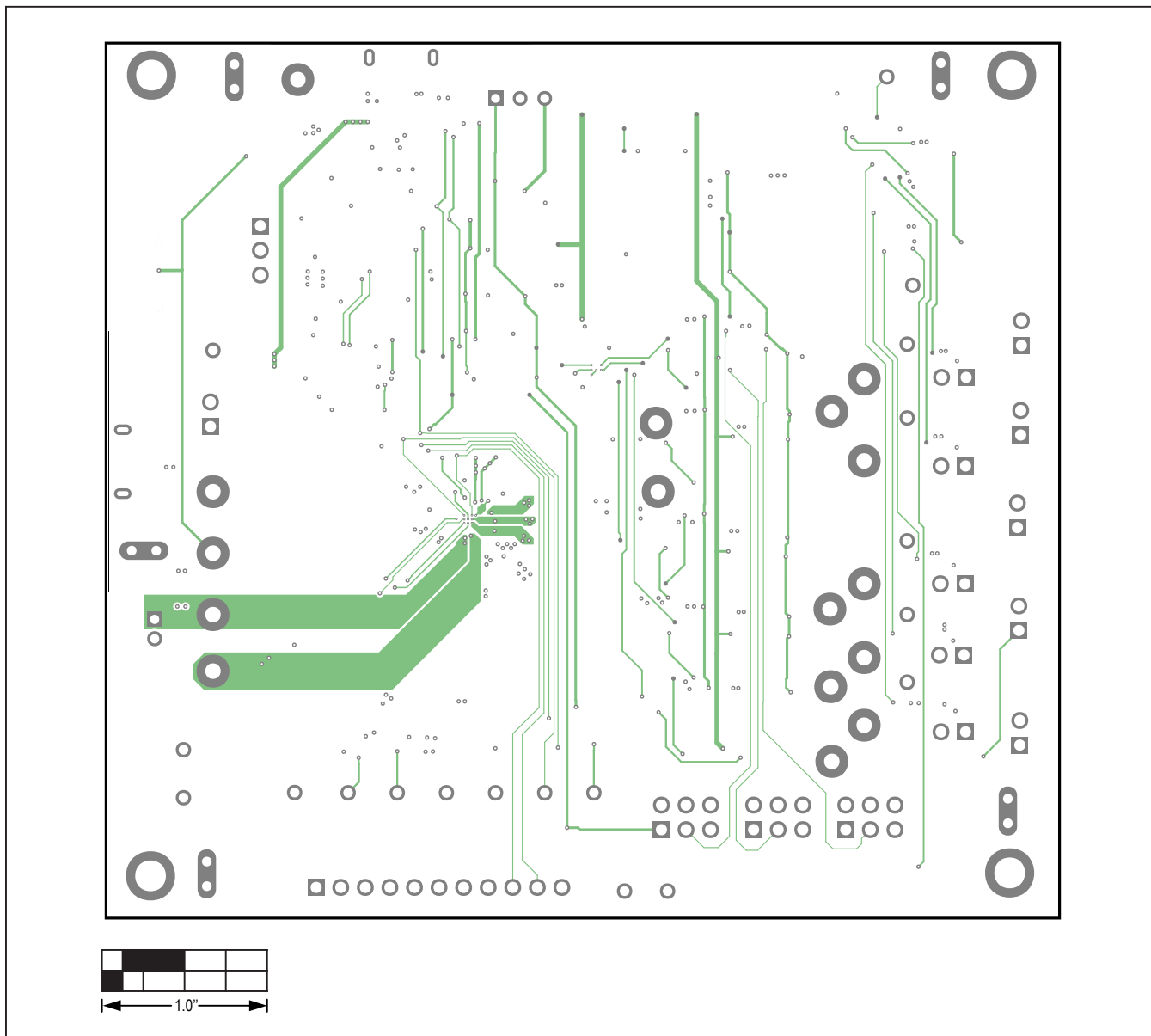

MAX77654 EV Kit PCB Layout—Internal Layer 3

MAX77654 EV Kit PCB Layouts (continued)

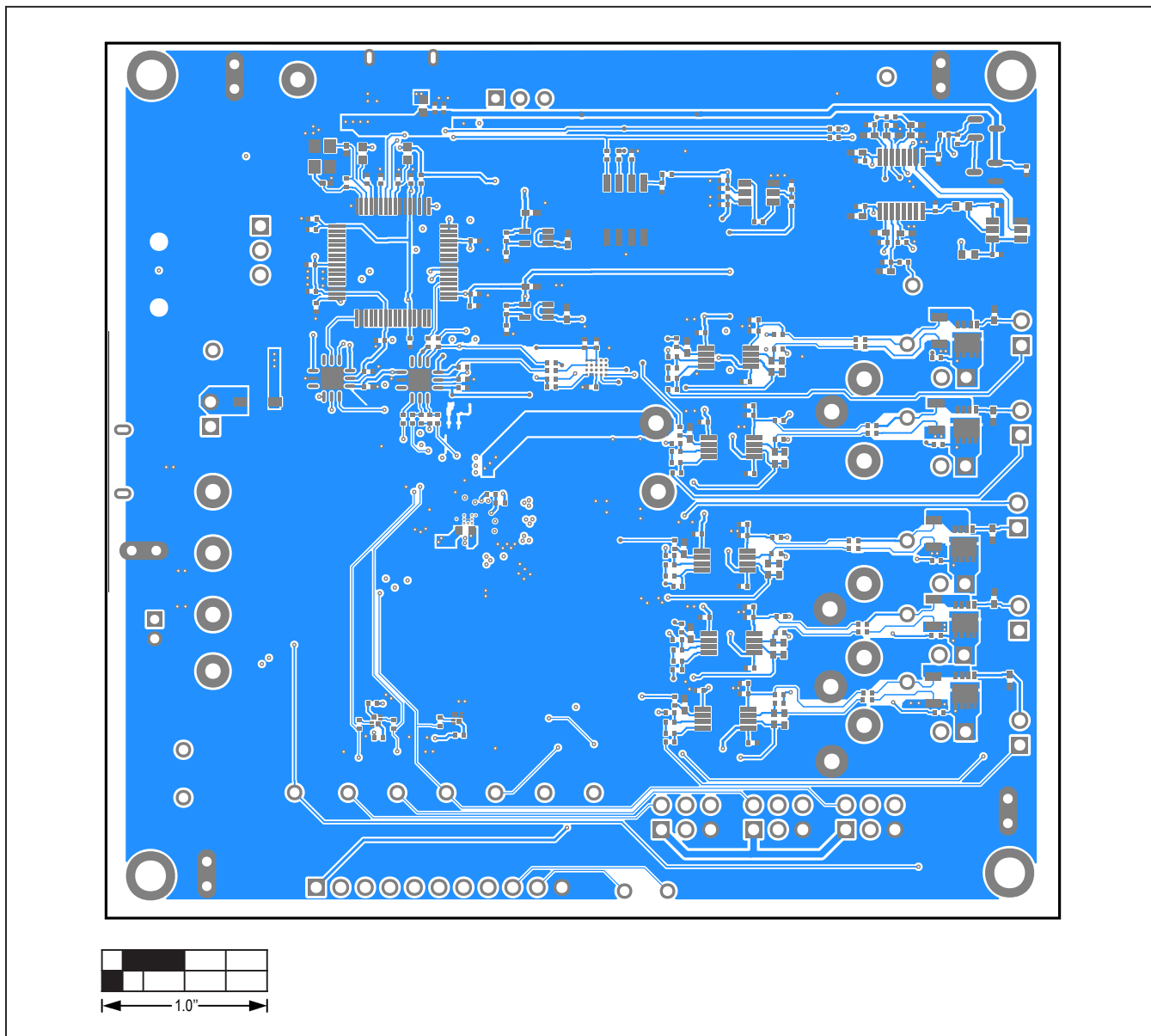

MAX77654 EV Kit PCB Layout—Bottom Layer

Revision History

REVISION NUMBER	REVISION DATE	DESCRIPTION	PAGES CHANGED
0	7/19	Initial release	—
1	10/19	Updated <i>Quick Start</i> section, replaced Figure 6, updated <i>Ordering Information</i> table, <i>MAX77654 EV Kit Bill of Materials</i> table, and MAX77654 EV Kit Schematic	5, 6, 10, 13, 15

For pricing, delivery, and ordering information, please visit Maxim Integrated's online storefront at <https://www.maximintegrated.com/en/storefront/storefront.html>.

Maxim Integrated cannot assume responsibility for use of any circuitry other than circuitry entirely embodied in a Maxim Integrated product. No circuit patent licenses are implied. Maxim Integrated reserves the right to change the circuitry and specifications without notice at any time.

X-ON Electronics

Largest Supplier of Electrical and Electronic Components

Click to view similar products for [Power Management IC Development Tools](#) category:

Click to view products by [Maxim](#) manufacturer:

Other Similar products are found below :

[EVAL-ADM1168LQEBZ](#) [EVB-EP5348UI](#) [MIC23451-AAAYFL EV](#) [MIC5281YMME EV](#) [DA9063-EVAL](#) [ADP122-3.3-EVALZ](#) [ADP130-0.8-EVALZ](#) [ADP130-1.2-EVALZ](#) [ADP130-1.5-EVALZ](#) [ADP130-1.8-EVALZ](#) [ADP1712-3.3-EVALZ](#) [ADP1714-3.3-EVALZ](#) [ADP1715-3.3-EVALZ](#) [ADP1716-2.5-EVALZ](#) [ADP1740-1.5-EVALZ](#) [ADP1752-1.5-EVALZ](#) [ADP1828LC-EVALZ](#) [ADP1870-0.3-EVALZ](#) [ADP1871-0.6-EVALZ](#) [ADP1873-0.6-EVALZ](#) [ADP1874-0.3-EVALZ](#) [ADP1882-1.0-EVALZ](#) [ADP199CB-EVALZ](#) [ADP2102-1.25-EVALZ](#) [ADP2102-1.875EVALZ](#) [ADP2102-1.8-EVALZ](#) [ADP2102-2-EVALZ](#) [ADP2102-3-EVALZ](#) [ADP2102-4-EVALZ](#) [ADP2106-1.8-EVALZ](#) [ADP2147CB-110EVALZ](#) [AS3606-DB](#) [BQ24010EVM](#) [BQ24075TEVM](#) [BQ24155EVM](#) [BQ24157EVM-697](#) [BQ24160EVM-742](#) [BQ24296MEVM-655](#) [BQ25010EVM](#) [BQ3055EVM](#) [NCV891330PD50GEVB](#) [ISLUSBI2CKIT1Z](#) [LM2744EVAL](#) [LM2854EVAL](#) [LM3658SD-AEV/NOPB](#) [LM3658SDEV/NOPB](#) [LM3691TL-1.8EV/NOPB](#) [LM4510SDEV/NOPB](#) [LM5033SD-EVAL](#) [LP38512TS-1.8EV](#)