

TABLE OF CONTENTS

General Description	1
Applications	1
Benefits and Features	1
Simplified Application Circuit	1
Absolute Maximum Ratings	6
Package Information	6
30 WLP 0.4mm Pitch	6
Electrical Characteristics - Top Level	6
Electrical Characteristics—SIMO Buck-Boost	9
Electrical Characteristics—I ² C Serial Interface	11
Typical Operating Characteristics	13
Bump Configuration	20
MAX77680/MAX77681	20
Bump Description	20
Detailed Description - Top Level	22
Support Materials	22
Top-Level Interconnect Simplified Diagram	23
Voltage Monitors	23
SYS POR Comparator	23
SYS Undervoltage-Lockout Comparator	23
SYS Overvoltage-Lockout Comparator	23
nEN Enable Input	24
nEN Manual Reset	24
nEN Dual-Functionality: Push-Button vs. Slide-Switch	24
nEN Debounce	25
Interrupts (nIRQ)	25
Reset Output (nRST)	25
Power Hold Input (PWR_HLD)	25
On/Off Controller	26
Flexible Power Sequencer (FPS)	30
Thermal Alarms and Protection	31
Register Map	31
Detailed Description—SIMO Buck-Boost	32
SIMO Features and Benefits	32
SIMO Control Scheme	33
SIMO Soft-Start	33
SIMO Output Voltage Configuration	34

TABLE OF CONTENTS (CONTINUED)

SIMO Active Discharge Resistance	34
SIMO Efficiency	34
SIMO Applications Information	34
SIMO Available Output Current	34
Inductor Selection	35
Input Capacitor Selection	36
Boost Capacitor Selection	36
Output Capacitor Selection	36
SIMO Switching Frequency	36
Unused SIMO Outputs	37
PCB Layout	38
Detailed Description—I ² C Serial Interface	38
Typical Application Circuits	39
SIMO Regulator using Hardware On-Key Enable	39
SIMO Regulator using Software Enable Control	40
Ordering Information	40
Revision History	41

LIST OF FIGURES

Figure 1. Top-Level Interconnect Simplified Diagram	23
Figure 2. nEN Usage Timing Diagram	24
Figure 3. Debounced Inputs Timing Diagram	25
Figure 4. Top-Level On/Off Controller	27
Figure 5. Power-Up/Down Sequence	29
Figure 6. Flexible Power Sequencer Timing Diagram	30
Figure 7. Startup Timing Diagram Due to nEN	31
Figure 8. SIMO Detailed Block Diagram	32
Figure 9. SIMO Switching Frequency Measurements	37
Figure 10. PCB Top-Metal and Component Layout Example	38

LIST OF TABLES

Table 1. Regulator Summary	22
Table 2. On/Off Controller Transitions.	28
Table 3. SIMO Available Output Current for Common Applications	35
Table 4. Example Inductors.	36
Table 5. I ² C Slave Address Options	39

Absolute Maximum Ratings

nEN, PWR_HLD, nIRQ, nRST to GND-0.3V to V_{SYS} + 0.3V
 SCL, SDA to GND-0.3V to V_{IO} + 0.3V
 SYS to GND -0.3V to +6.0V
 SYS to IN_SBB -0.3V to +0.3V
 nIRQ, nRST, SDA Continuous Current ±20mA
 IN_SBB to PGND -0.3V to +6.0V
 LXA Continuous Current (Note 1) 1.2A_{RMS}
 LXB Continuous Current (Note 2) 1.2A_{RMS}
 SBB0, SBB1, SBB2 to PGND (Note 3) -0.3V to +6.0V
 BST to IN_SBB -0.3V to +6.0V
 BST to LXB -0.3V to +6.0V

SBB0, SBB1, SBB2 Short-Circuit Duration Continuous
 PGND to GND -0.3V to +0.3V
 Operating Temperature Range -40°C to +85°C
 Junction Temperature +150°C
 Storage Temperature Range -65°C to +150°C
 Soldering Temperature (reflow) +260°C
 Continuous Power Dissipation (Multilayer Board)
 (T_A = +70°C, derate 20.4mW/°C above +70°C) 1632mW

- Note 1:** Note 1: LXA has internal clamping diodes to PGND and IN_SBB. It is normal for these diodes to briefly conduct during switching events. Avoid steady-state conduction of these diodes.
- Note 2:** Note 2: Do not externally bias LXB. LXB has an internal low-side clamping diode to PGND, and an internal high-side clamping diode that dynamically shifts to the selected SIMO output. It is normal for these internal clamping diodes to briefly conduct during switching events. When the SIMO regulator is disabled, the LXB to PGND absolute maximum voltage is -0.3V to V_{SBB0} +0.3V.
- Note 3:** Note 3: When the active discharge resistor is engaged, limit its power dissipation to an average of 10mW.

Stresses beyond those listed under "Absolute Maximum Ratings" may cause permanent damage to the device. These are stress ratings only, and functional operation of the device at these or any other conditions beyond those indicated in the operational sections of the specifications is not implied. Exposure to absolute maximum rating conditions for extended periods may affect device reliability.

Package Information

30 WLP 0.4mm Pitch

Package Code	W302H2+1
Outline Number	21-100047
Land Pattern Number	Refer to Application Note 1891
Thermal Resistance, Four-Layer Board:	
Junction to Ambient (θ _{JA})	49°C/W (2s2p board)

For the latest package outline information and land patterns (footprints), go to www.maximintegrated.com/packages. Note that a "+", "#", or "-" in the package code indicates RoHS status only. Package drawings may show a different suffix character, but the drawing pertains to the package regardless of RoHS status.

Package thermal resistances were obtained using the method described in JEDEC specification JESD51-7, using a four-layer board. For detailed information on package thermal considerations, refer to www.maximintegrated.com/thermal-tutorial.

Electrical Characteristics - Top Level

(V_{SYS} = V_{IN_SBB} = 3.7V, V_{IO} = 1.8V, limits are 100% production tested at T_A = +25°C, limits over the operating temperature range (T_A = -40°C to +85°C) are guaranteed by design and characterization, unless otherwise noted.)

PARAMETER	SYMBOL	CONDITIONS	MIN	TYP	MAX	UNITS
Operating Voltage Range	V _{SYS}		2.7		5.5	V

Electrical Characteristics - Top Level (continued)

(V_{SYS} = V_{IN_SBB} = 3.7V, V_{IO} = 1.8V, limits are 100% production tested at T_A = +25°C, limits over the operating temperature range (T_A = -40°C to +85°C) are guaranteed by design and characterization, unless otherwise noted.)

PARAMETER	SYMBOL	CONDITIONS		MIN	TYP	MAX	UNITS
Shutdown Supply Current	I _{SHDN}	Current measured into SYS and IN_SBB, all resources are off (SBB0, SBB1, SBB2), T _A = +25°C	Main bias is off (SBIA_EN = 0). This is the standby state		0.3	1	μA
			Main bias is on in low-power mode (SBIA_EN = 1, SBIA_LPM = 1)		1.0		
			Main bias is on in normal mode (SBIA_EN = 1, SBIA_LPM = 0)		28.0		
Quiescent Supply Current	I _Q	Current measured into SYS and IN_SBB. SBB0, SBB1, SBB2 are enabled	Main bias is in low-power mode (SBIA_LPM = 1)		3.0	13	μA
			Main bias is normal mode (SBIA_LPM = 0)		37.5	60	
POWER-ON RESET (POR)							
POR Threshold	V _{POR}	V _{SYS} falling		1.6	1.9	2.1	V
POR Threshold Hysteresis					100		mV
UNDERVOLTAGE LOCKOUT (UVLO)							
UVLO Threshold	V _{SYSUVLO}	V _{SYS} falling, UVLO_F[3:0] = 0xA		2.5	2.6	2.7	V
			V _{SYS} falling, UVLO_F[3:0] = 0xF	2.75	2.85	2.95	
UVLO Threshold Hysteresis	V _{SYSUVLO_HYS}	UVLO_H[3:0] = 0x5			300		mV
OVERVOLTAGE LOCKOUT (OVLO)							
OVLO Threshold	V _{SYSOVLO}	V _{SYS} rising		5.70	5.85	6.00	V
THERMAL MONITORS							
Overtemperature-Lockout Threshold	T _{OTLO}	T _J rising			165		°C
Thermal Alarm Temperature 1	T _{JAL1}	T _J rising			80		°C
Thermal Alarm Temperature 2	T _{JAL2}	T _J rising			100		°C
Thermal Alarm Temperature Hysteresis					15		°C
ENABLE INPUT (nEN)							
nEN Input Leakage Current	I _{nEN_LKG}	V _{SYS} = 5.5V, V _{nEN} = 0V, and 5.5V	T _A = +25°C	-1	±0.001	+1	μA
			T _A = +85°C		±0.01		

Electrical Characteristics - Top Level (continued)

(V_{SYS} = V_{IN_SBB} = 3.7V, V_{IO} = 1.8V, limits are 100% production tested at T_A = +25°C, limits over the operating temperature range (T_A = -40°C to +85°C) are guaranteed by design and characterization, unless otherwise noted.)

PARAMETER	SYMBOL	CONDITIONS	MIN	TYP	MAX	UNITS	
nEN Input Falling Threshold	V _{TH_nEN_F}	nEN falling	V _{SYS} - 1.4	V _{SYS} - 1.0		V	
nEN Input Rising Threshold	V _{TH_nEN_F}	nEN falling		V _{SYS} - 0.9	V _{SYS} - 0.6	V	
nEN Debounce Time	t _{DBNC_nEN}	DBEN_nEN = 0		100		μs	
		DBEN_nEN = 1		30		ms	
nEN Manual Reset Time	t _{MRST}	MRT_OTP = 0	14	16	20	s	
		MRT_OTP = 1	7	8	10.5		
POWER HOLD INPUT (PWR_HLD)							
PWR_HLD Input Leakage Current	I _{PWR_HLD_LK_G}	V _{SYS} = V _{IO} = 5.5V, V _{PWR_HLD} = 0V, and 5.5V	T _A = +25°C	-1	±0.001	+1	μA
			T _A = +85°C		±0.01		
PWR_HLD Input Voltage Low	V _{IL}	V _{IO} = 1.8V			0.3 x V _{IO}	V	
PWR_HLD Input Voltage High	V _{IH}	V _{IO} = 1.8V	0.7 x V _{IO}			V	
PWR_HLD Input Hysteresis	V _{HYS}	V _{IO} = 1.8V		50		mV	
PWR_HLD Glitch Filter	t _{PWR_HLD_GF}	Both rising and falling edges are filtered		100		μs	
PWR_HLD Wait Time	t _{PWR_HLD_WAIT}	Maximum time for PWR_HLD input to assert after nRST deasserts during the power-up sequence	3.5	4.0	5.0	s	
OPEN-DRAIN INTERRUPT OUTPUT (nIRQ)							
nIRQ Output Voltage Low	V _{OL}	I _{SINK} = 2mA			0.4	V	
nIRQ Output Falling Edge Time	t _{f_nIRQ}	C _{IRQ} = 25pF		2		ns	
nIRQ Output High Leakage Current	I _{nIRQ_LKG}	V _{SYS} = V _{IO} = 5.5V, nIRQ set to be high impedance (i.e., no interrupts), V _{nIRQ} = 0V and 5.5V	T _A = +25°C	-1	±0.001	+1	μA
			T _A = +85°C		±0.01		
OPEN-DRAIN RESET OUTPUT (nRST)							
nRST Output Voltage Low	V _{OL}	I _{SINK} = 2mA			0.4	V	
nRST Output Falling Edge Time	t _{f_nRST}	C _{RST} = 25pF		2		ns	
nRST Deassert Delay Time	t _{RSTODD}	See Figure 5 for more information		5.12		ms	
nRST Assert Delay Time	t _{RSTOAD}	See Figure 5 for more information		10.24		ms	

Electrical Characteristics - Top Level (continued)

(V_{sys} = V_{IN_SBB} = 3.7V, V_{IO} = 1.8V, limits are 100% production tested at T_A = +25°C, limits over the operating temperature range (T_A = -40°C to +85°C) are guaranteed by design and characterization, unless otherwise noted.)

PARAMETER	SYMBOL	CONDITIONS	MIN	TYP	MAX	UNITS	
nRST Output High Leakage Current	I _{nRST_LKG}	V _{sys} = V _{IO} = 5.5V, nRST set to be high impedance (i.e., not reset), V _{nRST} = 0V and 5.5V	T _A = +25°C	-1	±0.001	+1	μA
			T _A = +85°C		±0.01		
FLEXIBLE POWER SEQUENCER							
Power-Up Event Periods	t _{EN}	See Figure 6		1.28		ms	
Power-Down Event Periods	t _{DIS}	See Figure 6		2.56		ms	

Electrical Characteristics—SIMO Buck-Boost

(V_{sys} = 3.7V, V_{IN_SBB} = 3.7V, C_{SBBx} = 10μF, L = 1.5μH, limits are 100% production tested at T_A = +25°C, limits over the operating temperature range (T_A = -40°C to +85°C) are guaranteed by design and characterization, unless otherwise noted.)

PARAMETER	SYMBOL	CONDITIONS	MIN	TYP	MAX	UNITS
OUTPUT VOLTAGE RANGE (SBB0)						
Minimum Output Voltage				0.8		V
Maximum Output Voltage				2.375		V
Output DAC Bits				6		bits
Output DAC LSB Size				25		mV
OUTPUT VOLTAGE RANGE (SBB1)						
Minimum Output Voltage		MAX77680		0.8		V
		MAX77681		2.4		
Maximum Output Voltage		MAX77680		1.5875		V
		MAX77681		5.25		
Output DAC Bits				6		bits
Output DAC LSB Size		MAX77680		12.5		mV
		MAX77681		50		
OUTPUT VOLTAGE RANGE (SBB2)						
Minimum Output Voltage		MAX77680		0.8		V
		MAX77681		2.4		
Maximum Output Voltage		MAX77680		3.95		V
		MAX77681		5.25		
Output DAC Bits				6		bits
Output DAC LSB Size				50		mV

Electrical Characteristics—SIMO Buck-Boost (continued)

(V_{SYS} = 3.7V, V_{IN_SBB} = 3.7V, C_{SBBx} = 10 μ F, L = 1.5 μ H, limits are 100% production tested at T_A = +25°C, limits over the operating temperature range (T_A = -40°C to +85°C) are guaranteed by design and characterization, unless otherwise noted.)

PARAMETER	SYMBOL	CONDITIONS	MIN	TYP	MAX	UNITS	
OUTPUT VOLTAGE ACCURACY							
Output Voltage Accuracy		V _{SBBx} falling, threshold where LXA switches high. Specified as a percentage of target output voltage	T _A = +25°C	-2.5	+2.5	%	
			T _A = -40°C to +85°C	-4.0	+4.0		
TIMING CHARACTERISTICS							
Enable Delay		Delay time from the SIMO receiving its first enable signal to when it begins to switch in order to service that output.		60		μ s	
Soft-Start Slew Rate	dV/dt _{SS}		3.3	5.0	6.6	mV/ μ s	
POWER STAGE CHARACTERISTICS							
LXA Leakage Current		SBB0, SBB1, SBB2 are disabled, V _{IN_SBB} = 5.5V, V _{LXA} = 0V or 5.5V	T _A = +25°C	-1.0	\pm 0.1	+1.0	μ A
			T _A = +85°C		\pm 1.0		
LXB Leakage Current		SBB0, SBB1, SBB2 are disabled, V _{IN_SBB} = 5.5V, V _{LXA} = 0V or 5.5V, all V _{SBBx} = 5.5V	T _A = +25°C	-1.0	\pm 0.1	+1.0	μ A
			T _A = +85°C		\pm 1.0		
BST Leakage Current		V _{IN_SBB} = 5.5V, V _{LXB} = 5.5V, V _{BST} = 11V	T _A = +25°C		+0.01	+1.0	μ A
			T _A = +85°C		+0.1		
Disabled Output Leakage Current		SBB0, SBB1, SBB2 are disabled, active-discharge disabled (ADE_SBBx = 0), V _{SBBx} = 5.5V, V _{LXB} = 0V, V _{SYS} = V _{IN_SBB} = V _{BST} = 5.5V	T _A = +25°C		+0.1	+1.0	μ A
			T _A = +85°C		+0.2		
Active Discharge Impedance	R _{AD_SBBx}	SBB0, SBB1, SBB2 are disabled, active discharge enabled (ADE_SBBx = 1)	80	140	260	Ω	
CONTROL SCHEME							
Peak Current Limit (Note 4)	I _{P_SBB}	IP_SBBx = 0b11	0.414	0.500	0.586	A	
		IP_SBBx = 0b10	0.589	0.707	0.806		
		IP_SBBx = 0b01	0.713	0.866	0.947		
		IP_SBBx = 0b00	0.892	1.000	1.108		

Electrical Characteristics—I²C Serial Interface

(V_{SYS} = V_{IN_SBB} = 3.7V, V_{IO} = 1.8V, limits are 100% production tested at T_A = +25°C, limits over the operating temperature range (T_A = -40°C to +85°C) are guaranteed by design and characterization, unless otherwise noted.)

PARAMETER	SYMBOL	CONDITIONS	MIN	TYP	MAX	UNITS
POWER SUPPLY						
V _{IO} Voltage Range	V _{IO}		1.7	1.8	3.6	V
V _{IO} Bias Current		V _{IO} = 3.6V, V _{SDA} = V _{SCL} = 0V or 3.6V	-1	0	+1	μ A
		V _{IO} = 1.7V, V _{SDA} = V _{SCL} = 0V or 1.7V	-1	0	+1	
SDA AND SCL I/O STAGE						
SCL, SDA Input High Voltage	V _{IH}	V _{IO} = 1.7V to 3.6V	0.7 x V _{IO}			V
SCL, SDA Input Low Voltage	V _{IL}	V _{IO} = 1.7V to 3.6V	0.3 x V _{IO}			V
SCL, SDA Input Hysteresis	V _{HYS}		0.05 x V _{IO}			V
SCL, SDA Input Leakage Current	I _I	V _{IO} = 3.6V, V _{SCL} = V _{SDA} = 0V and 3.6V	-10		+10	μ A
SDA Output Low Voltage	V _{OL}	Sinking 20mA			0.4	V
SCL, SDA Pin Capacitance	C _I			10		pF
Output Fall Time from V _{IH} to V _{IL} (Note 4)	t _{OF}				120	ns
I²C-COMPATIBLE INTERFACE TIMING (HIGH-SPEED MODE, CB = 100pF) (Note 5)						
Clock Frequency	f _{SCL}				3.4	MHz
Setup Time REPEATED START Condition	t _{SU_STA}		160			ns
Hold Time (REPEATED) START Condition	t _{HD_STA}		160			ns
SCL Low Period	t _{LOW}		160			ns
SCL High Period	t _{HIGH}		60			ns
Data Setup Time	t _{SU_DAT}		10			ns
Data Hold Time	t _{HD_DAT}		0		70	ns
SCL Rise Time	t _{rCL}	T _A = +25°C	10		40	ns
Rise Time of SCL Signal after REPEATED START Condition and after Acknowledge Bit	t _{rCL1}	T _A = +25°C	10		80	ns
SCL Fall Time	t _{fCL}	T _A = +25°C	10		40	ns
SDA Rise Time	t _{rDA}	T _A = +25°C	10		80	ns
SDA Fall Time	t _{fDA}	T _A = +25°C	10		80	ns
Setup Time for STOP Condition	t _{SU_STO}		160			ns
Bus Capacitance	C _B				100	pF

Electrical Characteristics—I²C Serial Interface (continued)

(V_{SY}S = V_{IN_SBB} = 3.7V, V_{IO} = 1.8V, limits are 100% production tested at T_A = +25°C, limits over the operating temperature range (T_A = -40°C to +85°C) are guaranteed by design and characterization, unless otherwise noted.)

PARAMETER	SYMBOL	CONDITIONS	MIN	TYP	MAX	UNITS
Pulse Width of Suppressed Spikes	t _{SP}	Maximum pulse width of spikes that must be suppressed by the input filter		10		ns
I²C-COMPATIBLE INTERFACE TIMING (STANDARD, FAST, AND FAST-MODE PLUS) (Note 5)						
Clock Frequency	f _{SCL}		0		1000	kHz
Hold Time (REPEATED) START Condition	t _{HD_STA}		0.26			μs
SCL Low Period	t _{LOW}		0.5			μs
SCL High Period	t _{HIGH}		0.26			μs
Setup Time REPEATED START Condition	t _{SU_STA}		0.26			μs
Data Hold Time	t _{HD_DAT}		0			μs
Data Setup Time	t _{SU_DAT}		50			ns
Setup Time for STOP Condition	t _{SU_STO}		0.26			μs
Bus Free Time between STOP and START Condition	t _{BUF}		0.5			μs
Pulse Width of Suppressed Spikes	t _{SP}	Maximum pulse width of spikes that must be suppressed by the input filter		50		ns
I²C-COMPATIBLE INTERFACE TIMING (HIGH-SPEED MODE, C_B = 400pF) (Note 5)						
Clock Frequency	f _{SCL}				1.7	MHz
Setup Time REPEATED START Condition	t _{SU_STA}		160			ns
Hold Time (REPEATED) START Condition	t _{HD_STA}		160			ns
SCL Low Period	t _{LOW}		320			ns
SCL High Period	t _{HIGH}		120			ns
Data Setup Time	t _{SU_DAT}		10			ns
Data Hold Time	t _{HD_DAT}		0		150	ns
SCL Rise Time	t _{RCL}	T _A = +25°C	20		80	ns
Rise Time of SCL Signal after REPEATED START Condition and after Acknowledge Bit	t _{RCL1}	T _A = +25°C	20		80	ns
SCL Fall Time	t _{FCL}	T _A = +25°C	20		80	ns
SDA Rise Time	t _{RDA}	T _A = +25°C	20		160	ns
SDA Fall Time	t _{FDA}	T _A = +25°C	20		160	ns
Setup Time for STOP Condition	t _{SU_STO}		160			ns
Bus Capacitance	C _B				400	pF

Electrical Characteristics—^I2C Serial Interface (continued)

(V_{SYS} = V_{IN_SBB} = 3.7V, V_{IO} = 1.8V, limits are 100% production tested at T_A = +25°C, limits over the operating temperature range (T_A = -40°C to +85°C) are guaranteed by design and characterization, unless otherwise noted.)

PARAMETER	SYMBOL	CONDITIONS	MIN	TYP	MAX	UNITS
Pulse Width of Suppressed Spikes	t _{SP}	Maximum pulse width of spikes that must be suppressed by the input filter		10		ns

Note 4: Typical values align with bench observations using the stated conditions. Minimum and maximum values are tested in production with DC currents. See the [Typical Operating Characteristics](#) SIMO switching waveforms to gain more insight on this specification.

Note 5: Design guidance only. Not production tested.

Typical Operating Characteristics

(Typical Applications Circuit, V_{SYS} = V_{IN_SBB} = 3.7V, V_{IO} = 1.8V, L = 1.5µH, T_A = +25°C, unless otherwise noted.)

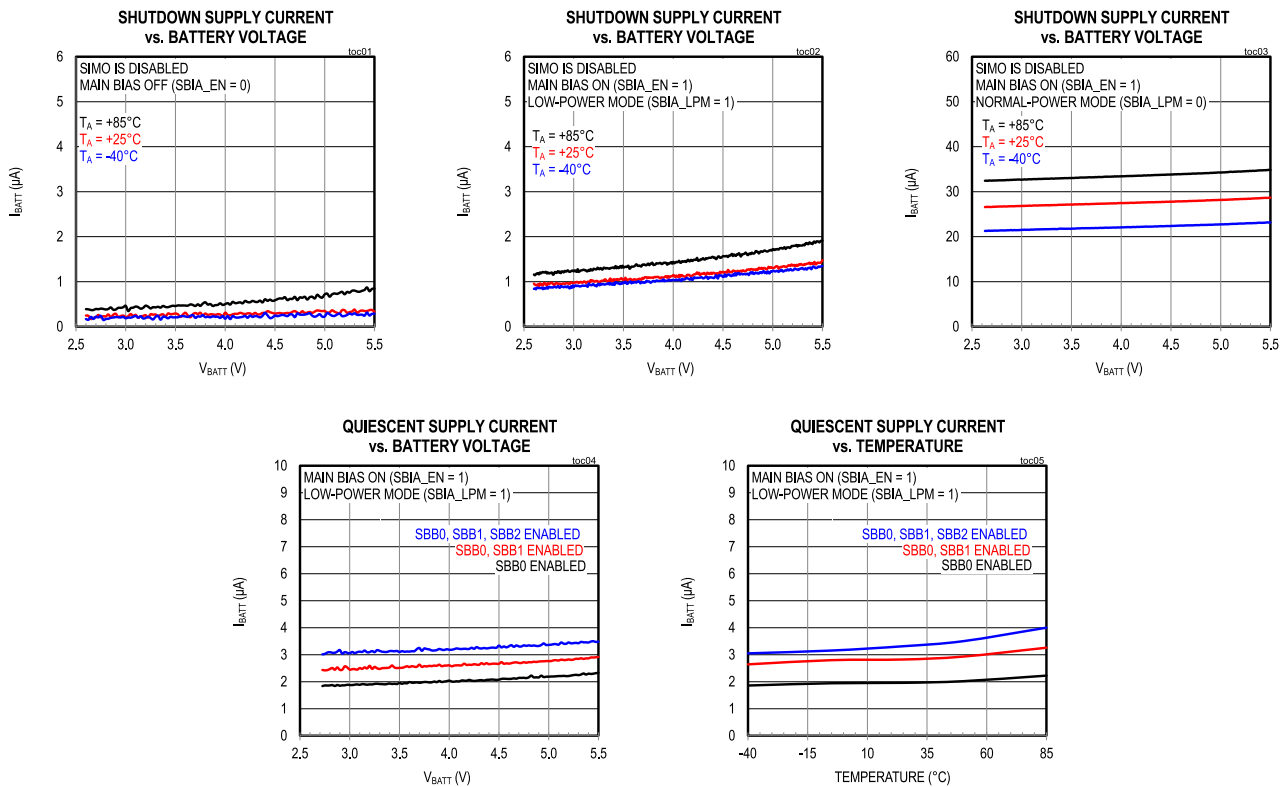

Typical Operating Characteristics (continued)

(Typical Applications Circuit, V_{SYS} = V_{IN_SBB} = 3.7V, V_{IO} = 1.8V, L = 1.5µH, T_A = +25°C, unless otherwise noted.)

(Typical Applications Circuit, V_{SYS} = V_{IN_SBB} = 3.7V, V_{IO} = 1.8V, L = 2.2µH (TOKO DFE2012210S-2R2M, 127mΩ, 2.0mm x 1.2mm x 1.0mm), T_A = +25°C, unless otherwise noted.)

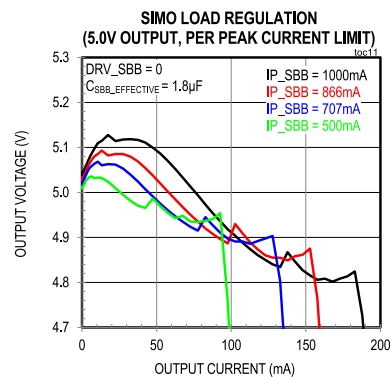
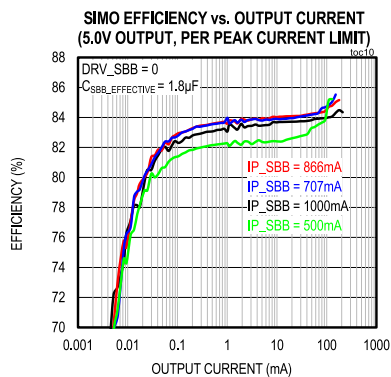
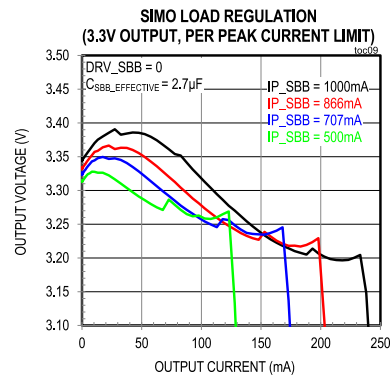
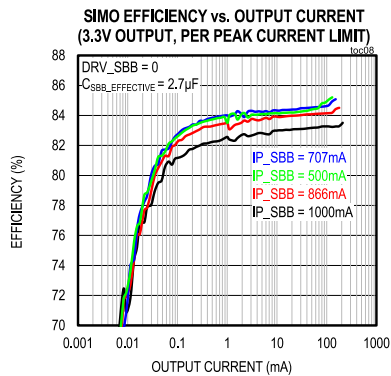
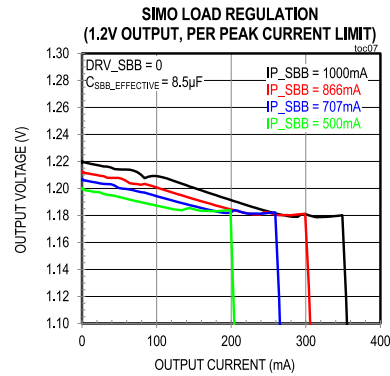
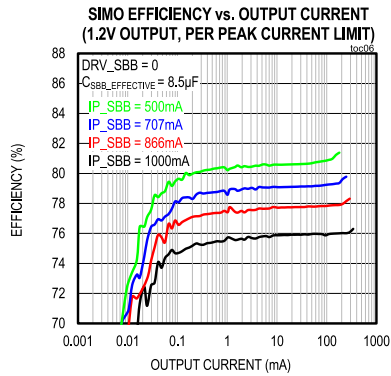

Typical Operating Characteristics (continued)

(Typical Applications Circuit, V_{SYS} = V_{IN_SBB} = 3.7V, V_{IO} = 1.8V, L = 1.5µH, T_A = +25°C, unless otherwise noted.)

(Typical Applications Circuit, V_{SYS} = V_{IN_SBB} = 3.7V, V_{IO} = 1.8V, L = 2.2µH (TOKO DFE2012210S-2R2M, 127mΩ, 2.0mm x 1.2mm x 1.0mm), T_A = +25°C, unless otherwise noted.)

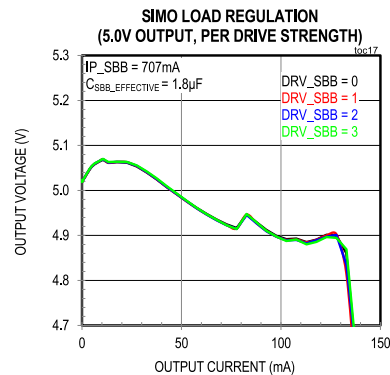
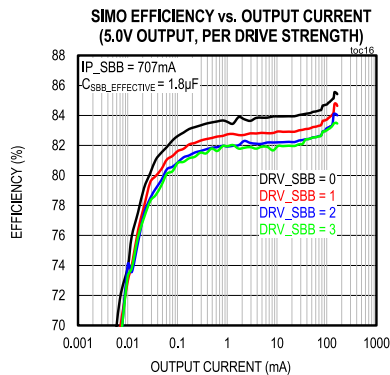
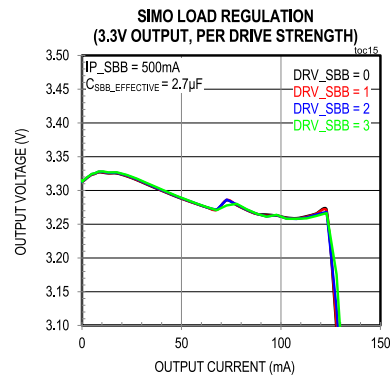
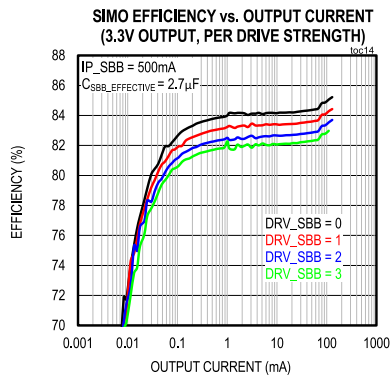
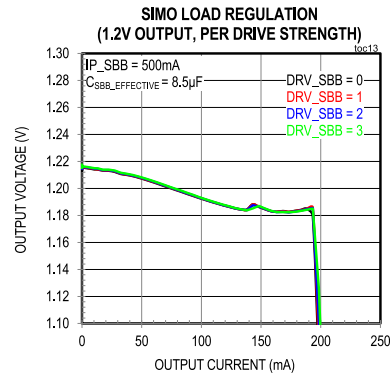
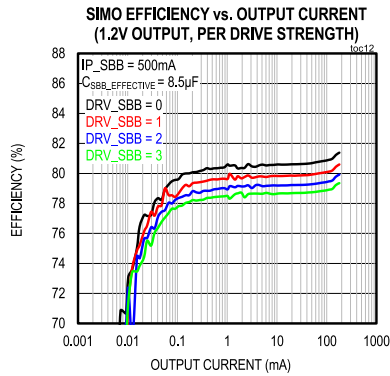

Typical Operating Characteristics (continued)

(Typical Applications Circuit, V_{SYS} = V_{IN_SBB} = 3.7V, V_{IO} = 1.8V, L = 1.5µH, T_A = +25°C, unless otherwise noted.)

(Typical Applications Circuit, V_{SYS} = V_{IN_SBB} = 3.7V, V_{IO} = 1.8V, L = 2.2µH (TOKO DFE2012210S-2R2M, 127mΩ, 2.0mm x 1.2mm x 1.0mm), T_A = +25°C, unless otherwise noted.)

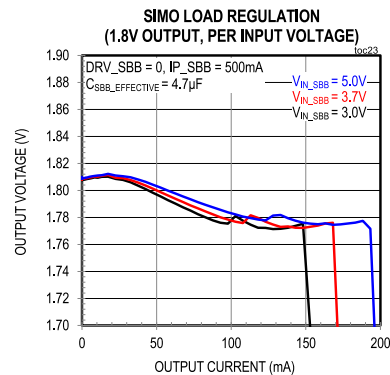
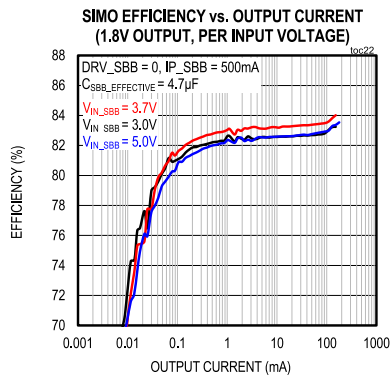
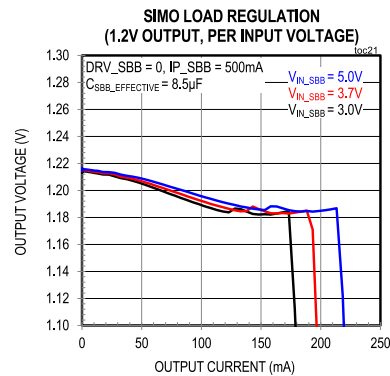
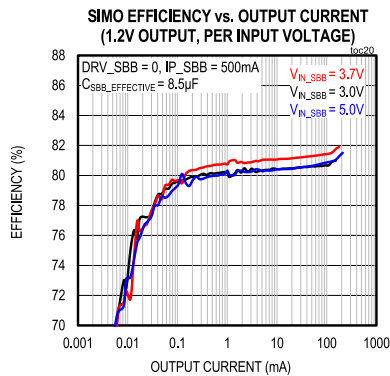
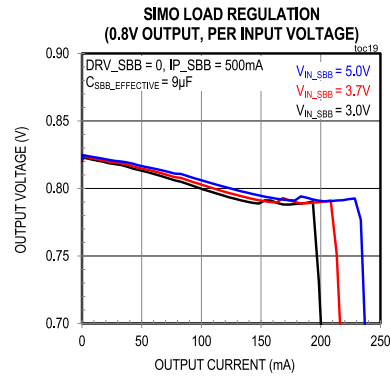
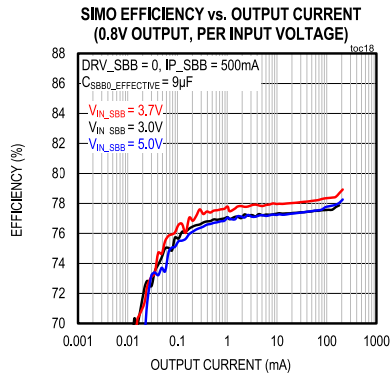

Typical Operating Characteristics (continued)

(Typical Applications Circuit, V_{SYS} = V_{IN_SBB} = 3.7V, V_{IO} = 1.8V, L = 1.5µH, T_A = +25°C, unless otherwise noted.)

(Typical Applications Circuit, V_{SYS} = V_{IN_SBB} = 3.7V, V_{IO} = 1.8V, L = 2.2µH (TOKO DFE2012210S-2R2M, 127mΩ, 2.0mm x 1.2mm x 1.0mm), T_A = +25°C, unless otherwise noted.)

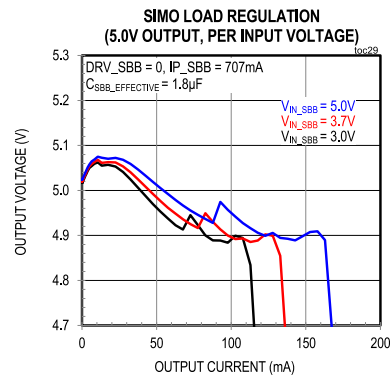
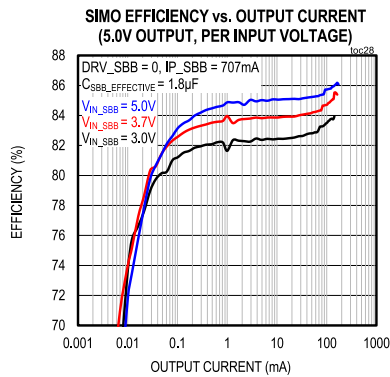
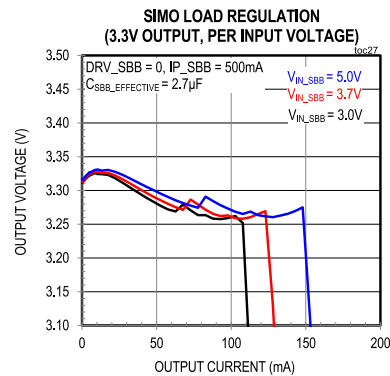
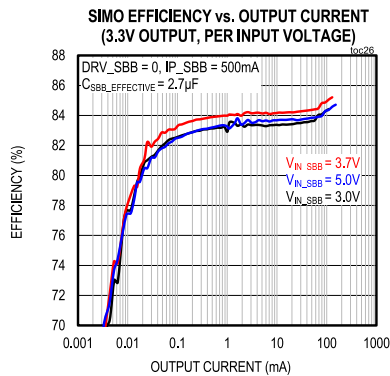
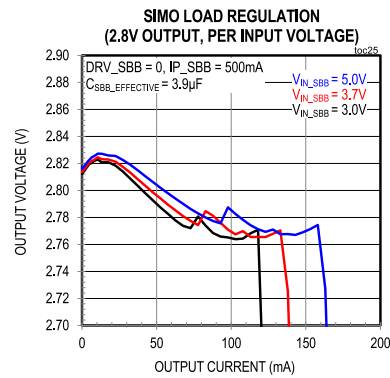
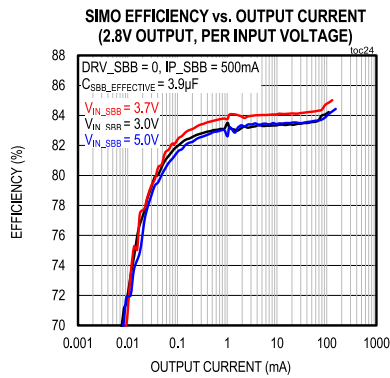

Typical Operating Characteristics (continued)

(Typical Applications Circuit, V_{sys} = V_{IN_SBB} = 3.7V, V_{IO} = 1.8V, L = 1.5µH, T_A = +25°C, unless otherwise noted.)

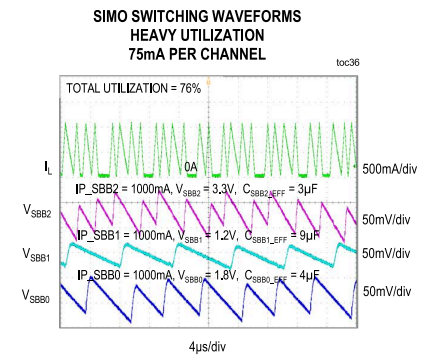
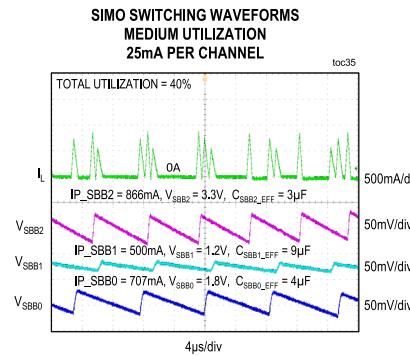
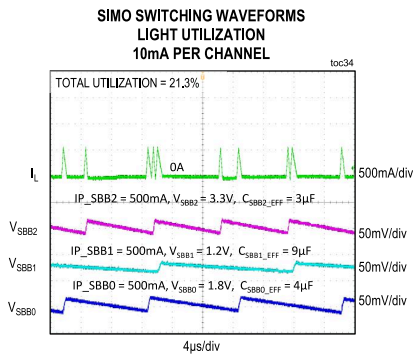
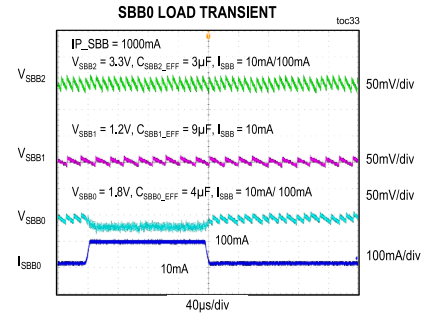
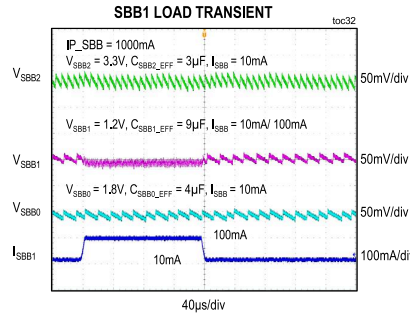
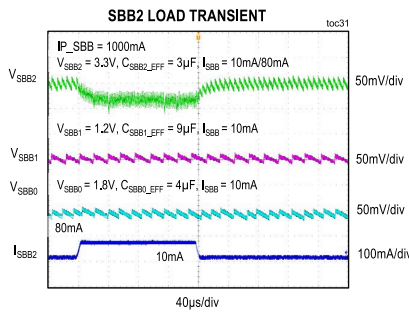
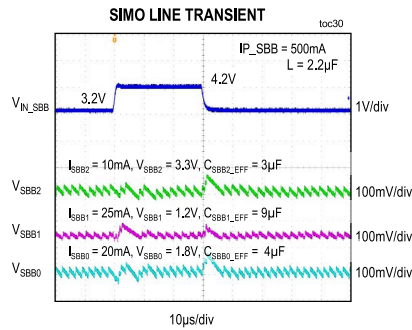

Typical Operating Characteristics (continued)

(Typical Applications Circuit, V_{SYS} = V_{IN_SBB} = 3.7V, V_{IO} = 1.8V, L = 1.5μH, T_A = +25°C, unless otherwise noted.)

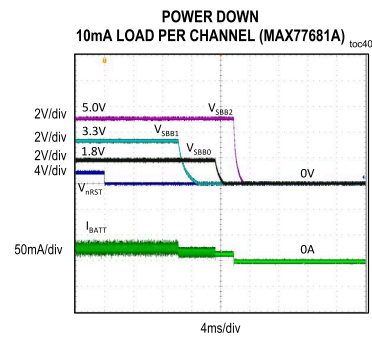
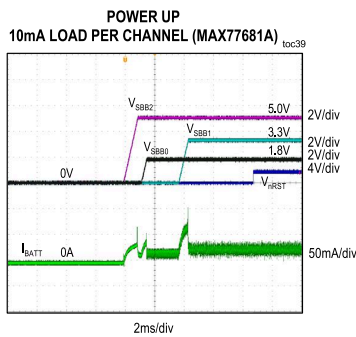
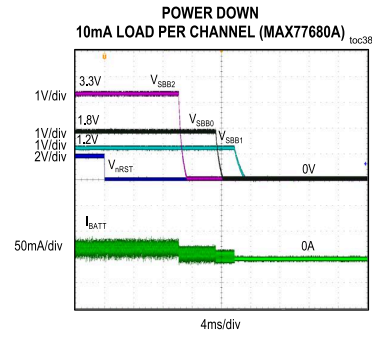
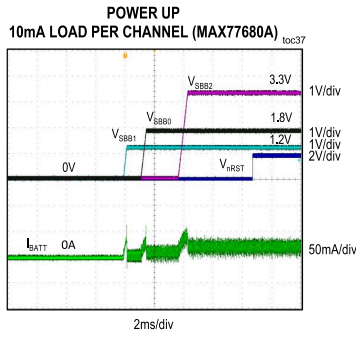

Bump Configuration

MAX77680/MAX77681

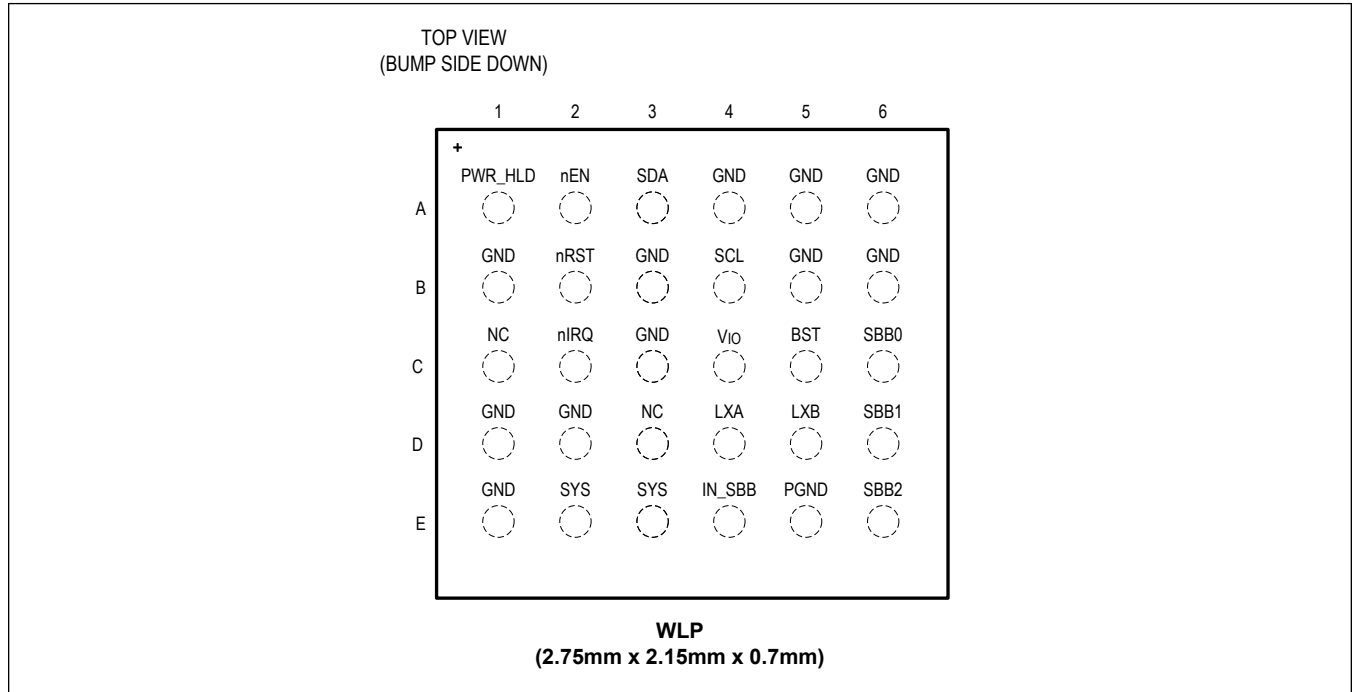

Bump Description

PIN	NAME	FUNCTION	TYPE
TOP-LEVEL			
A1	PWR_HLD	Active-High Power Hold Input. Assert PWR_HLD to keep the on/off controller in its on state. If PWR_HLD is not needed, connect it to SYS and use the SFT_RST bits to power the device down.	digital input
A2	nEN	Active-Low Enable Input. EN supports push-button or slide-switch configurations.	digital input
A3	SDA	I ² C Data	digital i/o
B4	SCL	I ² C Clock	digital input
B2	nRST	Active-Low, Open-Drain Reset Output. Connect a 100kΩ pullup resistor between RST and a voltage equal to or less than V _{SYS} .	digital output
C2	nIRQ	Active-Low, Open-Drain Interrupt Output. Connect a 100kΩ pullup resistor between IRQ and a voltage equal to or less than V _{SYS} .	digital output
E2, E3	SYS	System Power Output. SYS provides power to the system resources as well as the control logic of the device. Connect to IN_SBB and bypass to GND with a 22µF ceramic capacitor.	power output
A4, A5, A6, B1, B3, B5, B6, C3, D1, D2, E1	GND	Quiet Ground. Connect GND and PGND to the low-impedance ground plane of the PCB.	ground

Bump Description (continued)

PIN	NAME	FUNCTION	TYPE
C4	V _{IO}	I ² C Interface Power	power input
C1, D3	NC	No Connection. Not internally connected.	
SIMO BUCK-BOOST			
E4	IN_SBB	SIMO Power Input. Connect IN_SBB to SYS and bypass to PGND with a 22 μ F ceramic capacitor as close as possible to the IN_SBB pin.	power input
C6	SBB0	SIMO Buck-Boost Output 0. SBB0 is the power output for channel 0 of the SIMO buck-boost. Bypass SBB0 to PGND with a 10 μ F ceramic capacitor.	power output
D6	SBB1	SIMO Buck-Boost Output 1. SBB1 is the power output for channel 1 of the SIMO buck-boost. Bypass SBB1 to PGND with a 10 μ F ceramic capacitor.	power output
E6	SBB2	SIMO Buck-Boost Output 2. SBB2 is the power output for channel 2 of the SIMO buck-boost. Bypass SBB2 to PGND with a 10 μ F ceramic capacitor.	power output
C5	BST	SIMO Power Input for the High-Side Output NMOS Drivers. Connect a 3300pF ceramic capacitor between BST and LXB.	power input
D4	LXA	Switching Node A. LXA is driven between PGND and IN_SBB when any SIMO channel is enabled. LXA is driven to PGND when all SIMO channels are disabled. Connect a 1.5 μ H inductor between LXA and LXB.	power i/o
D5	LXB	Switching Node B. LXB is driven between PGND and SBBx when SBBx is enabled. LXB is driven to PGND when all SIMO channels are disabled. Connect a 1.5 μ H inductor between LXA and LXB.	power i/o
E5	PGND	Power ground for the SIMO low-side FETs. Connect both PGND and GND to the low-impedance ground plane of the PCB.	ground

Detailed Description - Top Level

The MAX77680/MAX77681 provide highly-integrated power solutions for low-power applications where small size, low quiescent current, and efficiency are critical. The device integrates a single-inductor, multiple-output (SIMO) buck-boost regulator with three output channels. See [Table 1](#). The three outputs of the SIMO regulator share capacity and are typically capable of providing 300mA total to the system.

A bidirectional I²C serial interface allows for configuring and checking the status of the device. An internal on/off controller interfaces to either a momentary push-button on-key or an on-key slider-switch. Furthermore, the on/off controller provides power-up/down sequencing for the regulators as well as other functions such as manual reset.

Table 1. Regulator Summary

REGULATOR NAME	REGULATOR TOPOLOGY	MAXIMUM I _{OUT} (mA)	V _{IN} RANGE (V)	MAX77680 V _{OUT} RANGE/ RESOLUTION	MAX77681 V _{OUT} RANGE/ RESOLUTION
SBB0	SIMO	up to 300*	2.7 to 5.5	0.8V to 2.375V in 25mV steps	0.8V to 2.375V in 25mV steps
SBB1	SIMO	up to 300*	2.7 to 5.5	0.8V to 1.5875V in 12.5mV steps	2.4V to 5.25V in 50mV steps
SBB2	SIMO	up to 300*	2.7 to 5.5	0.8V to 3.95V in 50mV steps	2.4V to 5.25V in 50mV steps

*Shared capacity with other SBBx channels. See the [SIMO Available Output Current](#) section for more information.

Support Materials

The following support materials are available for these devices.

- [AN6472: MAX77680/MAX77681 Programmer's Guide](#) provides a description of all device registers and software advice.
- [AN6473: MAX77680/MAX77681 I²C-Compatible Serial Interface Implementation Guide](#) provides a detailed look at the I²C serial interface and standard read/write patterns.
- [MAX77680/MAX77681 SIMO Calculator](#) details the SIMO design procedure. See the [SIMO Available Output Current](#) section of the data sheet for more information.

Visit the product page at www.maximintegrated.com/MAX77680 and/or [contact Maxim](#) for more information.

Top-Level Interconnect Simplified Diagram

Figure 1 shows simplified internal signal routing.

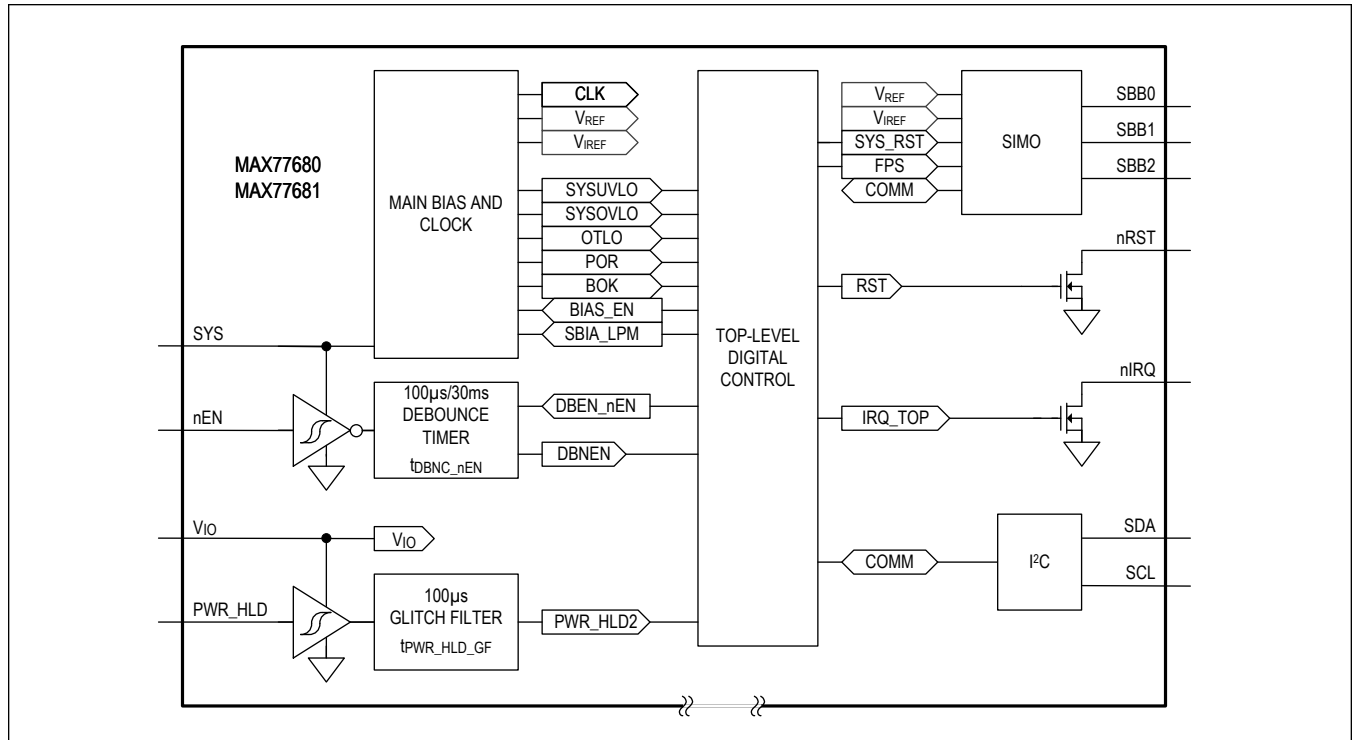

Figure 1. Top-Level Interconnect Simplified Diagram

Voltage Monitors

SYS POR Comparator

The SYS POR comparator monitors V_{SYS} and generates a power-on reset signal (POR). When V_{SYS} is below V_{POR} , the device is held in reset (SYSRST = 1). When V_{SYS} rises above V_{POR} , internal signals and on-chip memory stabilize and the device is released from reset (SYSRST = 0).

SYS Undervoltage-Lockout Comparator

The SYS undervoltage-lockout (UVLO) comparator monitors V_{SYS} and generates a SYSUVLO signal when the V_{SYS} falls below the UVLO threshold. The SYSUVLO signal is provided to the top-level digital controller. See Figure 4 and Table 2 for additional information regarding the UVLO comparator:

- When the device is in the STANDBY state, the UVLO comparator is disabled.
- When transitioning out of the STANDBY state, the UVLO comparator is enabled allowing the device to check for sufficient input voltage. If the device has sufficient input voltage, it can transition to the on-state; if there is insufficient input voltage, the device transitions back to the STANDBY state.

SYS Overvoltage-Lockout Comparator

The devices are rated for 5.5V maximum operating voltage (V_{SYS}) with an absolute maximum input voltage of 6.0V. An overvoltage-lockout monitor increases the robustness of the device by inhibiting operation when the supply voltage is greater than $V_{SYSOVLO}$. See Figure 4 and Table 2 for additional information regarding the OVLO comparator:

- When the device is in the STANDBY state, the OVLO comparator is disabled.

nEN Enable Input

nEN is an active-low internally debounced digital input that typically comes from the system's on-key. The debounce time is programmable with DBEN_nEN. The primary purpose of this input is to generate a wake-up signal for the PMIC that turns on the SIMO. Maskable rising/falling interrupts are available for nEN (nEN_R and nEN_F) for alternate functionality.

The nEN input can be configured to work either with a momentary push-button (nEN_MODE = 0) or a persistent slide-switch (nEN_MODE = 1). See Figure 2 for more information. In both push-button mode and slide-switch mode, the on/off controller looks for a falling edge on the nEN input to initiate a power-up sequence.

nEN Manual Reset

nEN works as a manual reset input when the on/off controller is in the on via on/off controller state. The manual reset function is useful for forcing a power-down in case the communication with the processor fails. When nEN is configured for a push-button mode and the input is asserted (nEN = low) for an extended period (t_{MRST}), the on/off controller initiates a power-down sequence and goes to standby mode. When nEN is configured for a slide-switch mode and the input is deasserted (nEN = high) for an extended period (t_{MRST}), the on/off controller initiates a power-down sequence and goes to standby mode.

A dedicated internal oscillator is used to create the 30ms (t_{DBNC_nEN}) and 8s/16s (t_{MRST}) timers for nEN. Whenever the device is actively counting either of these times, the supply current increases by the oscillator's supply current (65µA when the battery voltage is at 3.7V). As soon as the event driving the timer goes away or is fulfilled, the oscillator automatically turns off and its supply current goes away.

nEN Dual-Functionality: Push-Button vs. Slide-Switch

The nEN digital input can be configured to work with a push-button switch or a slide-switch. Figure 2 shows nEN's dual functionality for power-on sequencing and manual reset. The default configuration of the device is push-button mode (nEN_MODE = 0) and no additional programming is necessary. Applications that use a slide-switch on-key configuration must set nEN_MODE = 1 within t_{MRST}.

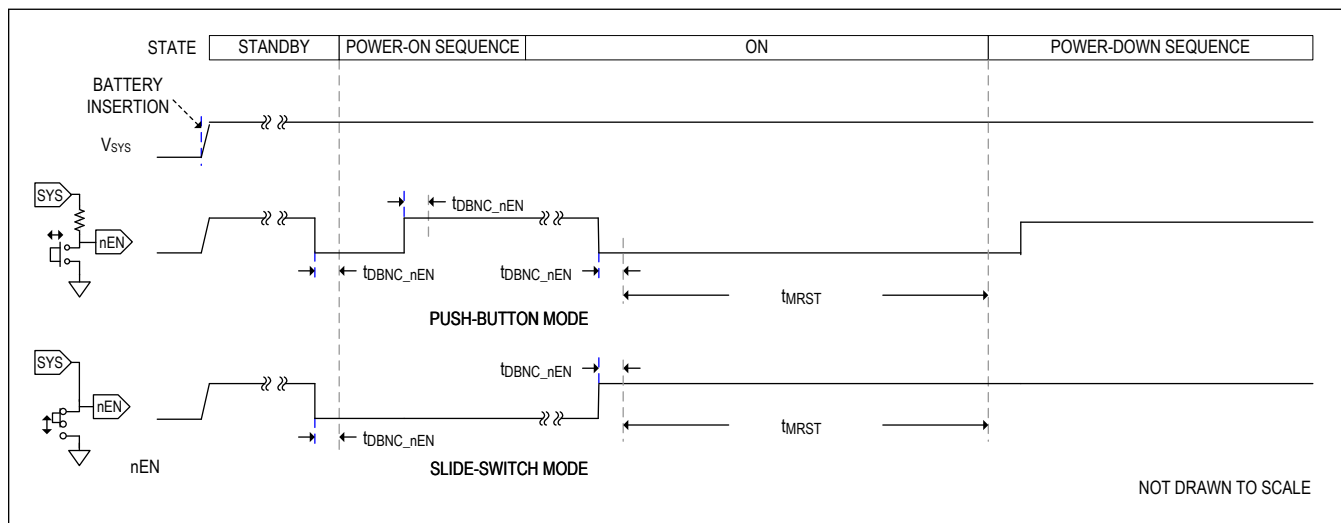

Figure 2. nEN Usage Timing Diagram

nEN Debounce

nEN is debounced on both rising and falling edges to reject undesired transitions. The input must be at a stable logic level for the entire debounce period for the output to change its logic state. [Figure 3](#) shows an example timing diagram for the nEN debounce.

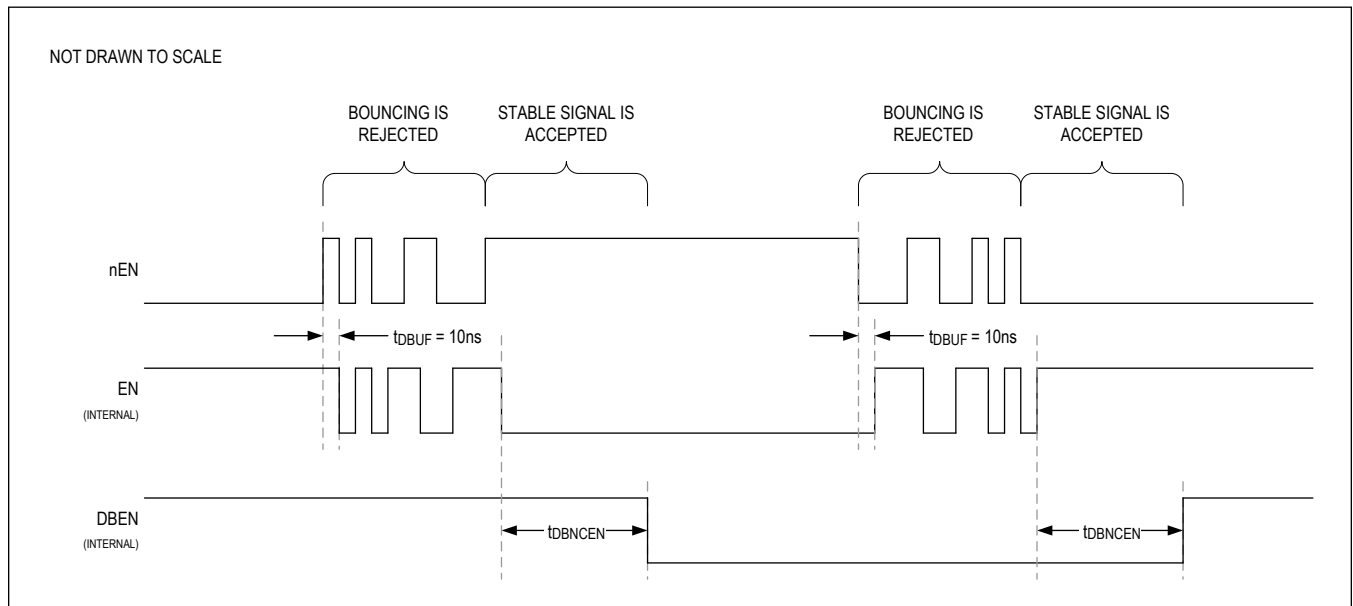

Figure 3. Debounced Inputs Timing Diagram

Interrupts (nIRQ)

nIRQ is an active-low, open-drain output that is typically routed to the host processor's interrupt input to signal an important change in the device's status. Refer to the [Programmer's Guide](#) for a comprehensive list of all interrupt bits and status registers.

A pullup resistor to a voltage less than or equal to V_{SYS} is required for this node. nIRQ is the logical NOR of all unmasked interrupt bits in the register map.

All interrupts are masked by default. Masked interrupt bits do not cause the nIRQ pin to change. Unmask the interrupt bits to allow nIRQ to assert.

Reset Output (nRST)

nRST is an open-drain, active-low output that is typically used to hold the processor in a reset state when the device is powered down. During a power-up sequence, the nRST deasserts after the last regulator in the power-up chain is enabled (t_{RSTODD}). During a power-down sequence, the nRST output asserts before any regulator is powered down (t_{RSTOAD}). See [Figure 5](#) for nRST timing.

A pullup resistor to a voltage less than or equal to V_{SYS} is required for this node.

Power Hold Input (PWR_HLD)

PWR_HLD is an active-high digital input. PWR_HLD has a 100µs glitch filter (t_{PWR_HLD_GF}). As shown in [Figure 1](#), the output of this glitch filter is PWR_HLD2 that drives the top-level digital control. [Figure 4](#) and its associated transition [Table 2](#) shows how PWR_HLD is processed by the top-level digital control.

- After the power-up sequence, the system processor must assert PWR_HLD within the PWR_HLD wait time ($t_{PWR_HLD_WAIT}$) to hold the power supply in the on-state. If the PWR_HLD input is not asserted within the $t_{PWR_HLD_WAIT}$ period, a power-down sequence is initiated.
- While in the on-state, the system processor must assert PWR_HLD as long as power is required. If the system processor wants to turn off, it can either pull PWR_HLD low or it can write the SFT_RST bits to execute the software cold reset (SFT_CRST) or software off (SFT_OFF) functions to execute the power-down sequence.
- If the power hold function is not used, connect PWR_HLD to SYS and use the SFT_RST bits to power the device down.

On/Off Controller

The on/off controller monitors multiple power-up (wakeup) and power-down (shutdown) conditions to enable or disable the SIMO channels.

The basic function of the on/off controller is to control the power sequencer. See [Figure 4](#) and [Table 2](#). A typical use case is described as follows:

1. Start in the no-power state.
2. Apply a battery to the system and transition through path 1 and 2 to the standby state.
3. Press the system's on-key (nEN = low) and transition through path 3A and 4 to the "PWR_HLD?" state.
4. The processor boots up and drives PWR_HLD high, which drives the transition through path 4C to the on state.
5. The device performs its desired functions in the on through on/off controller state. when it is ready to turn off, the processor drives PWR_HLD low that drives the transition through path 5B and 8 to the standby state.

The SIMO can be enabled through the I²C interface for systems that do not require a hardware (on-key) input. Connect nEN to SYS and follow this procedure:

1. Start in the no-power state.
2. Apply a battery to the system and transition through path 1 and 2 to the standby state.
3. Go to the on via software state by writing SBIA_EN = 1 through I²C.
4. In the on via software state, the host controller can now enable/disable SIMO outputs through I²C writes.
5. To return to standby state (shutdown), first disable all SIMO outputs then write SBIA_EN = 0.

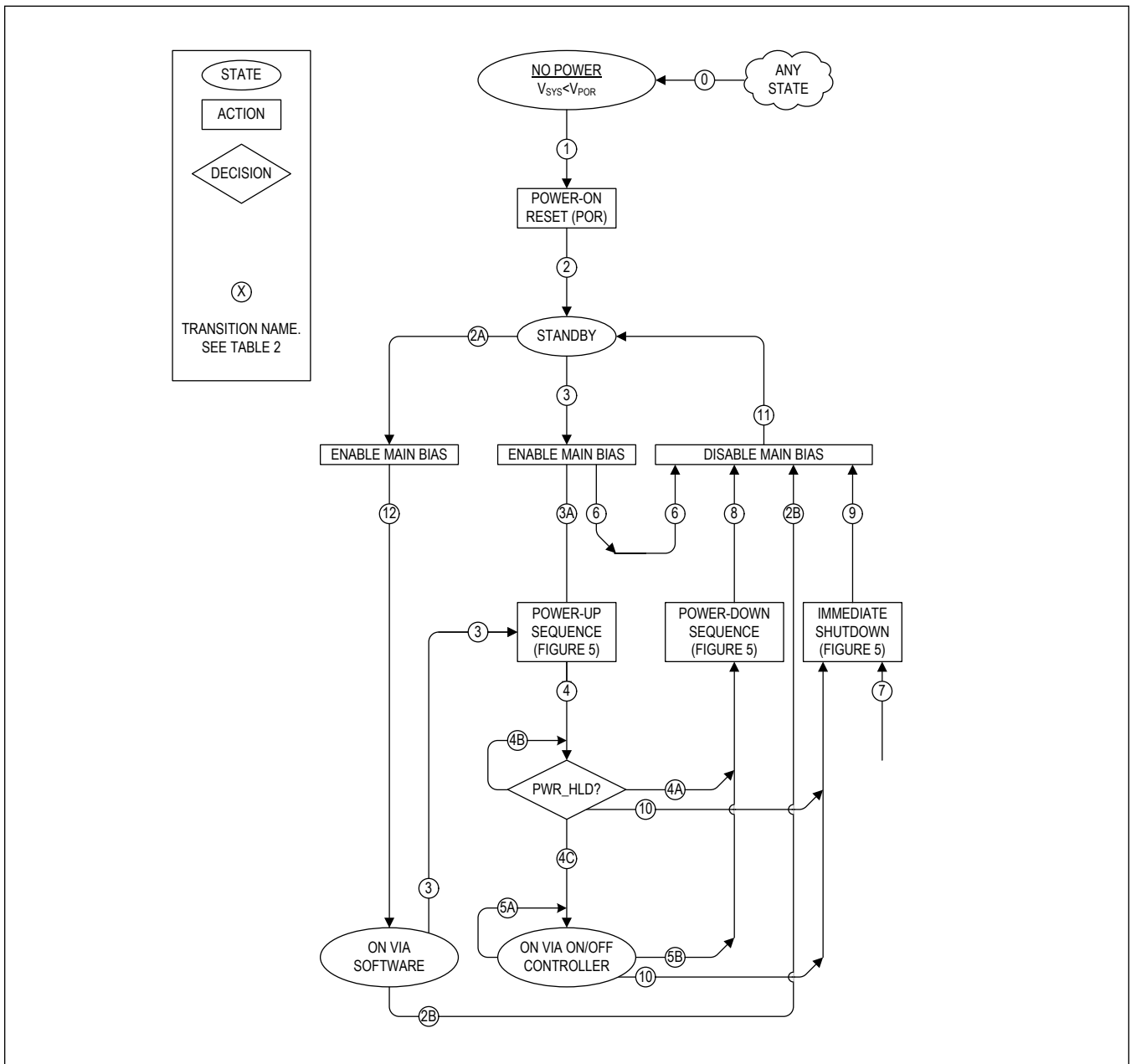

Figure 4. Top-Level On/Off Controller

Table 2. On/Off Controller Transitions

TRANSITION/ STATE	CONDITION
0	System voltage is below the POR threshold ($V_{SYS} < V_{POR}$).
1	System voltage is above the POR threshold ($V_{SYS} > V_{POR}$).
2	Internal signals and on-chip memory stabilize and the device is released from reset.
STANDBY	The device is waiting for a wake-up signal or an I ² C command to enable the main bias circuits. * This is the lowest current state of the device (I _Q = 0.3 μ A typ). * Main bias circuits are off, POR comparator is on. * I ² C is on when V _{IO} is valid. * Peripheral functions do not operate in this state because the main bias circuits are off. To utilize a function, enter the on through software or on through on/off controller states.
2A	Main bias circuits enabled through I ² C (SBIA_EN = 1).
2B	Main bias circuits disabled through I ² C (SBIA_EN = 0).
ON VIA SOFTWARE	The main bias circuits are enabled through software and all peripheral functions can be manually enabled or disabled through I ² C.
3	A wake-up signal has been received. * A debounced on-key (nEN) falling edge has been detected (DBNEN = 1) or * Internal wake-up flag has been set due to SFT_RST = 0b01 (WKUP = 1)
3A	Main bias circuits are OK (BOK = 1)
4	Power-up sequence complete.
4A	PWR_HLD wait time has expired and PWR_HLD2 is low ($t > t_{PWR_HLD_WAIT}$ && PWR_HLD2 = 0).
4B	PWR_HLD wait time has not expired and PWR_HLD2 is low ($t < t_{PWR_HLD_WAIT}$ && PWR_HLD2 = 0).
4C	PWR_HLD2 = 1
ON VIA ON/OFF CONTROLLER	On state. * All flexible power sequencers (FPS) are on. * The main bias circuits are enabled. * I _Q = 3 μ A (typ) with all regulators enabled (no load) and the main bias circuits in low-power mode.
5A	PWR_HLD2 = 1
5B	PWR_HLD2 = 0 OR System overtemperature lockout ($T_J > T_{OTLO}$) or Software cold reset (SFT_RST[1:0] = 0b01) or Software power off (SFT_RST[1:0] = 0b10) or Manual reset occurred. See the nEN Manual Reset section for more information.
6	System overtemperature lockout ($T_J > T_{OTLO}$) or System undervoltage lockout ($V_{SYS} < V_{SYSUVLO} + V_{SYSUVLO_HYS}$) or System overvoltage lockout ($V_{SYS} > V_{SYSOVLO}$)
7	System undervoltage lockout ($V_{SYS} < V_{SYSUVLO}$) or System overvoltage lockout ($V_{SYS} > V_{SYSOVLO}$) Note: The overvoltage-lockout transition does not apply to the ON VIA SOFTWARE state.
8	Finished with the power-down sequence.
9	Finished with immediate shutdown.
10	System overtemperature lockout ($T_J > T_{OTLO}$).
11	Done disabling main bias.

Table 2. On/Off Controller Transitions (continued)

12	Done enabling main bias.
----	--------------------------

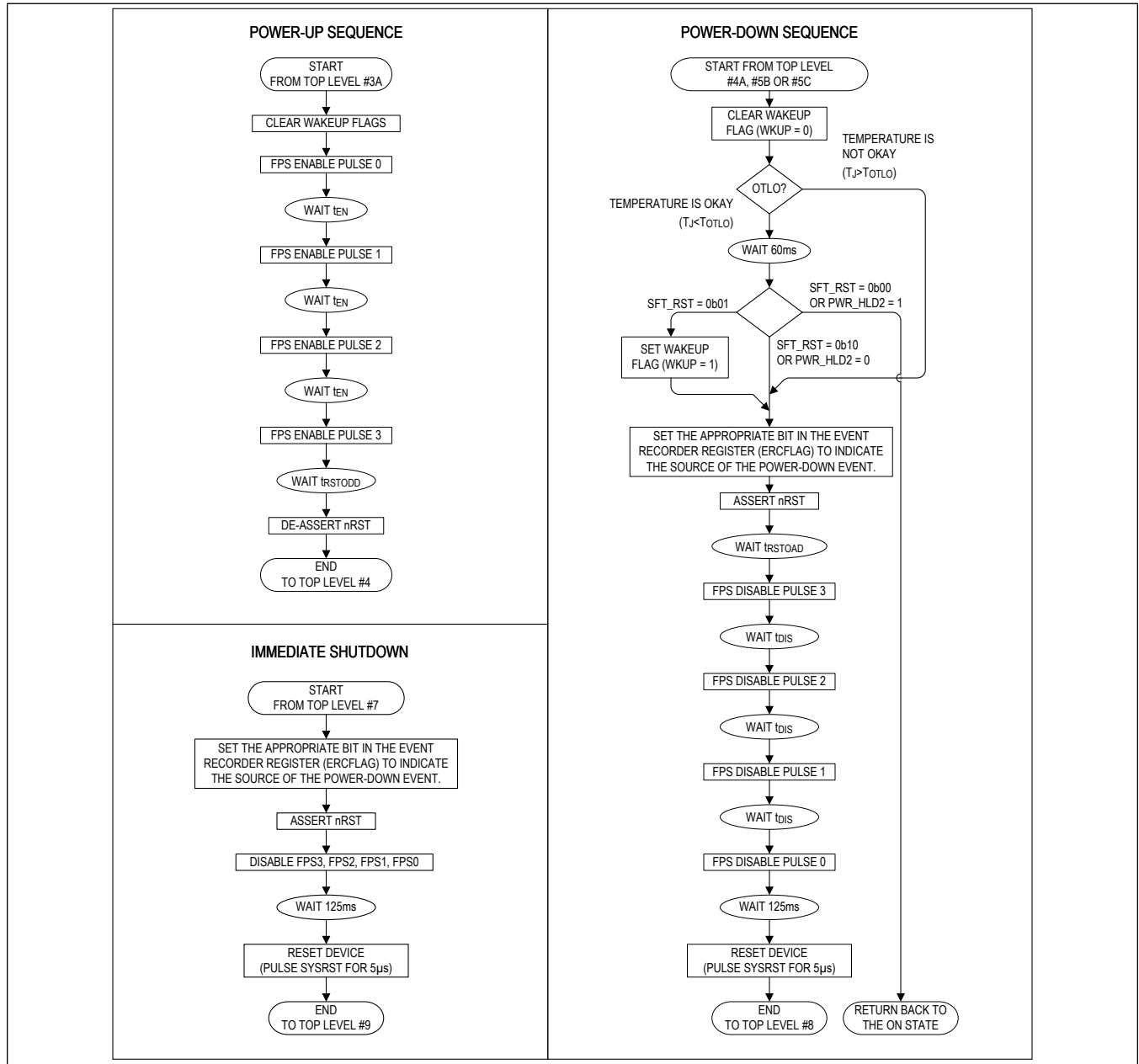

Figure 5. Power-Up/Down Sequence

Flexible Power Sequencer (FPS)

The FPS allows SIMO channels to power up under hardware or software control. Additionally, each channel can power up independently or together with adjustable power-up and power-down delays (sequencing). [Figure 6](#) shows four resources powering up under FPS control.

The FPS consists of 1 master sequencing timer and 3 slave resources (SBB0, SBB1, SBB2). When the FPS is enabled, a master timer generates four sequencing events for device power-up and power-down.

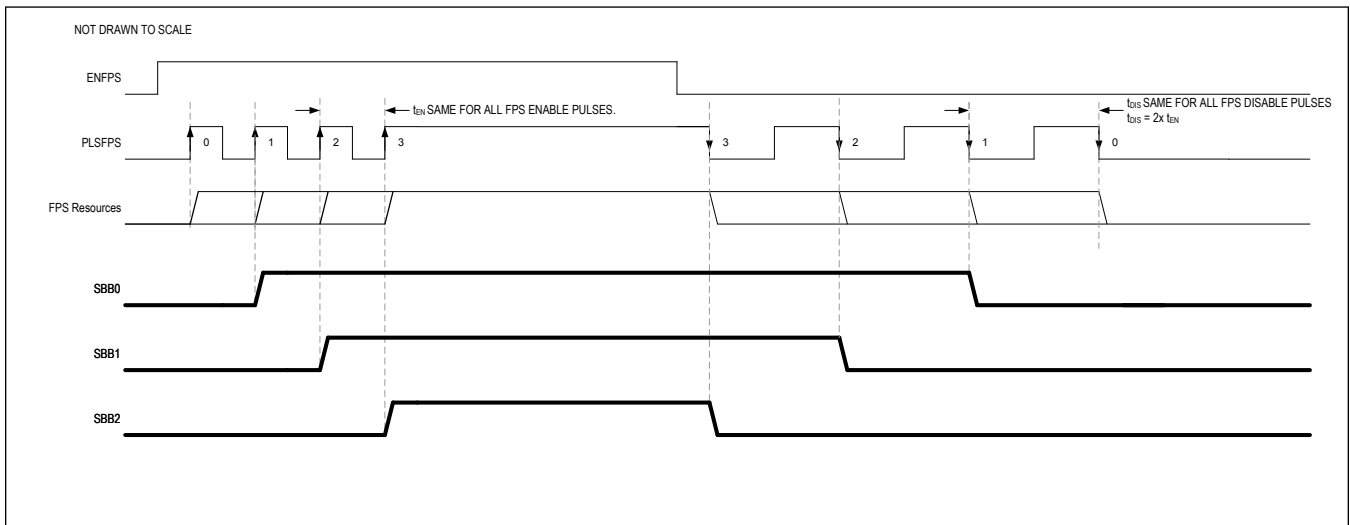

Figure 6. Flexible Power Sequencer Timing Diagram

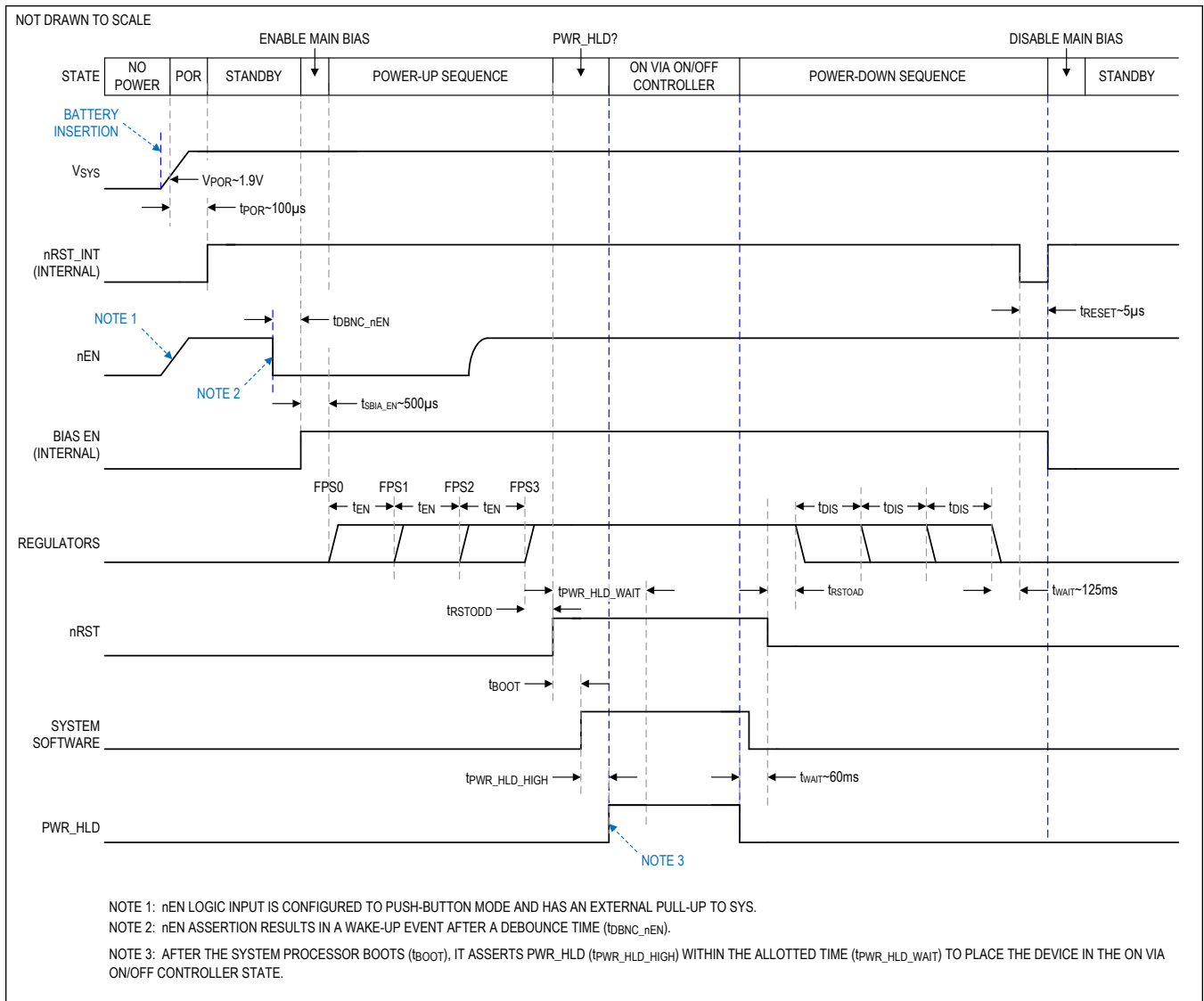

Figure 7. Startup Timing Diagram Due to nEN

Thermal Alarms and Protection

The devices have thermal alarms to monitor if the junction temperature rises above 80°C (T_{JAL1}) and 100°C (T_{JAL2}). Over-temperature lockout (OTLO) is entered if the junction temperature exceeds T_{OTLO} (approximately 165°C typ). OTLO causes transition 10 in Figure 4 which causes the SIMO to immediately shutdown from the on via on/off controller state. Resources do not enable until the temperature falls below T_{OTLO} by approximately 15°C.

The TJAL1_S and TJAL2_S status bits continuously indicate the junction temperature alarm status. Maskable interrupts are available to signal a change in either of these bits. Refer to the [Programmer's Guide](#) for details.

Register Map

The register map and register reset conditions are detailed in the [Programmer's Guide](#).

Detailed Description—SIMO Buck-Boost

The devices have a micropower single-inductor, multiple-output (SIMO) buck-boost DC-to-DC converter designed for applications that emphasize low supply current and small solution size (Figure 8). A single inductor is used to regulate three separate outputs, saving board space while delivering better total system efficiency than equivalent power solutions using one buck and linear regulators.

The SIMO configuration utilizes the entire battery voltage range due to its ability to create output voltages that are above, below, or equal to the input voltage. Peak inductor current for each output is programmable to optimize the balance between efficiency, output ripple, EMI, PCB design, and load capability.

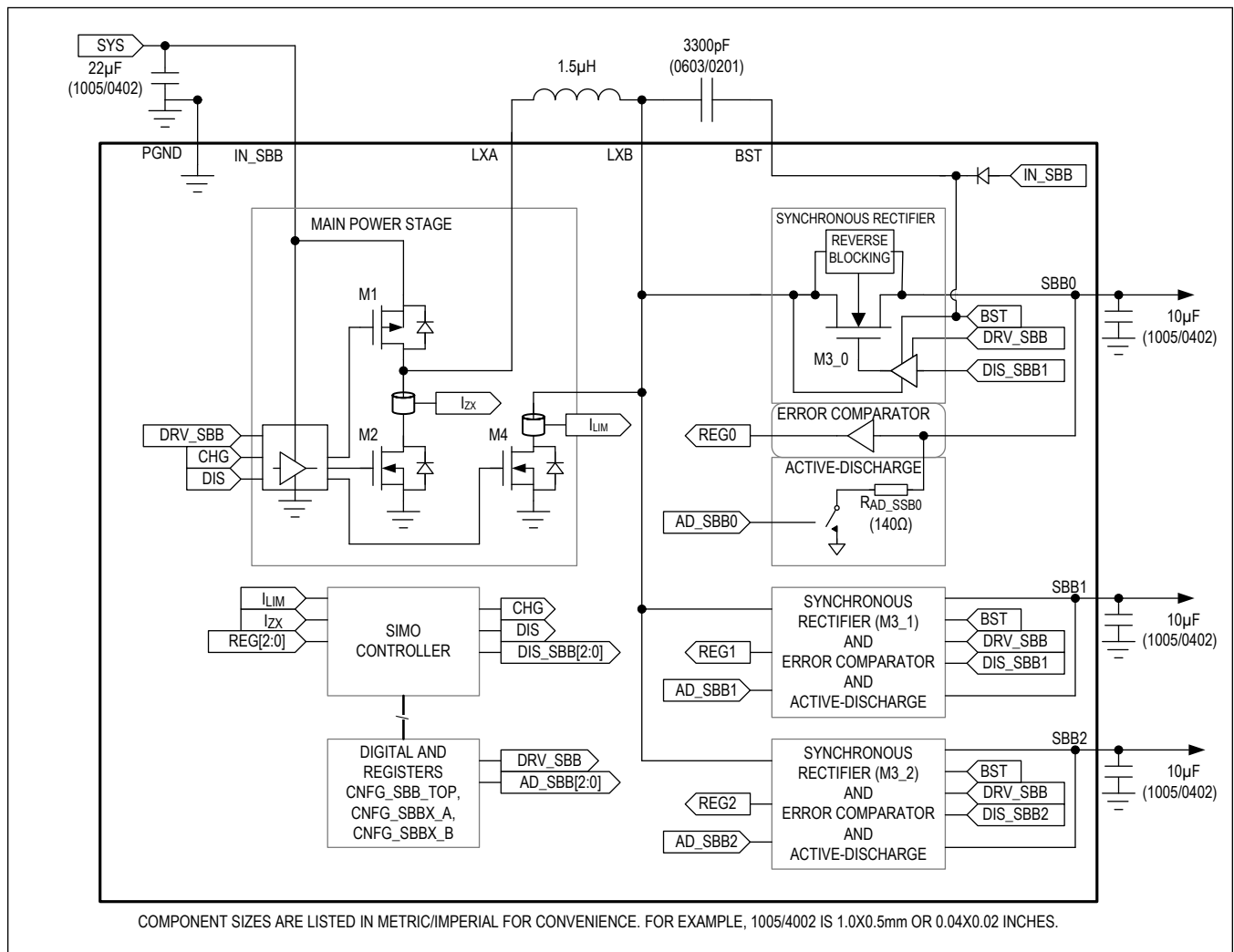

Figure 8. SIMO Detailed Block Diagram

SIMO Features and Benefits

- 3 Output Channels
- Ideal for Low-Power Designs
 - Delivers > 300mA at 1.8V from a 3.7V Input
 - ±3% Accurate Output Voltage
- Small Solution Size

- Multiple Outputs from a Single 1.5µH Inductor
- Small 10µF (0402) Output Capacitors
- Flexible and Easy to Use
 - Single Mode of Operation
 - Glitchless Transitions Between Buck, Buck-Boost, and Boost Scenarios
 - Programmable Peak Inductor Current
 - Programmable On-Chip Active Discharge
- Long Battery Life
 - High-Efficiency, > 87% at 3.3V Output
 - Better Total System Efficiency than Buck + LDOs
 - Low Quiescent Current, 1µA per Output
 - Low Input Operating Voltage, 2.7V (min)

SIMO Control Scheme

The SIMO buck-boost is designed to service multiple outputs simultaneously. A proprietary controller ensures that all outputs get serviced in a timely manner, even while multiple outputs are contending for the energy stored in the inductor. When no regulator needs service, the state machine rests in a low-power rest state.

See [Figure 8](#). When the controller determines that a regulator requires service, it charges the inductor (M1 + M4) until the peak current limit is reached ($I_{LIM} = I_{P_SBB}$). The inductor energy then discharges (M2 + M3_x) into the output until the current reaches zero (I_{ZX}). In the event that multiple output channels need servicing at the same time, the controller ensures that no output utilizes all of the switching cycles. Instead, cycles interleave between all the outputs that are demanding service, while outputs that do not need service are skipped.

SIMO Soft-Start

The soft-start feature of the SIMO limits inrush current during startup. The soft-start feature is achieved by limiting the slew rate of the output voltage during start up to dV/dt_{SS} (5mV/µs typ).

More output capacitance results in higher input current surges during start up. The following set of equations and example describes the input current surge phenomenon during start up.

The current into the output capacitor (I_{CSBB}) during soft-start is:

$$I_{CSBB} = C_{SBB} \frac{dV}{dt_{SS}} \quad \left(\text{Equation 1} \right)$$

where:

- C_{SBB} is the capacitance on the output of the regulator
- dV/dt_{SS} is the voltage change rate of the output

The input current (I_{IN}) during soft-start is:

$$I_{IN} = \frac{(I_{CSBB} + I_{LOAD}) \frac{V_{SBBx}}{V_{IN}}}{\xi} \quad \left(\text{Equation 2} \right)$$

where:

- I_{CSBB} is from the calculation above
- I_{LOAD} is current consumed from the external load
- V_{SBBx} is the output voltage
- V_{IN} is the input voltage
- ξ is the efficiency of the regulator

For example, given the following conditions, the peak input current (I_{IN}) during soft-start is approximately 71mA:

Given:

- V_{IN} is 3.5V
- V_{SBB2} is 3.3V
- C_{SBB2} = 10μF
- dV/dt_{SS} = 5mV/μs
- R_{LOAD2} = 330Ω (I_{LOAD2} = 3.3V/330Ω = 10mA)
- ξ is 80%

Calculation:

- I_{CSBB} = 10μF x 5mV/μs (from Equation 1)
- I_{CSBB} = 50mA
- $I_{IN} = \frac{(50\text{mA} + 10\text{mA}) \frac{3.3\text{V}}{3.5\text{V}}}{0.85}$ (from Equation 1)
- I_{IN} = 71mA

SIMO Output Voltage Configuration

Each SIMO buck-boost channel has a dedicated register to program its target output voltage (TV_SBBx) and its peak current limit (IP_SBBx). Additional controls are available for enabling/disabling the active-discharge resistors (ADE_SBBx), as well as enabling/disabling the SIMO buck-boost channels (EN_SBBx). For a full description of bits, registers, default values, and reset conditions, refer to the [Programmer's Guide](#).

SIMO Active Discharge Resistance

Each SIMO buck-boost channel has an active-discharge resistor (R_{AD_SBBx}) that is automatically enabled/disabled based on a ADE_SBBx and the status of the SIMO regulator. The active discharge feature may be enabled (ADE_SBBx = 1) or disabled (ADE_SBBx = 0) independently for each SIMO channel. Enabling the active discharge feature helps ensure a complete and timely power down of all system peripherals. If the active-discharge resistor is enabled by default, then the active-discharge resistor is on whenever V_{SYS} is below V_{SYSUVLO} and above V_{POR}.

These resistors discharge the output when ADE_SBBx = 1, and their respective SIMO channel is off. Note if the regulator is forced on through EN_SBBx = 0b110 or 0b111, then the resistors do not discharge the output even if the regulator is disabled by the main-bias.

Note that when V_{SYS} is less than 1.0V, the NMOS transistors that control the active-discharge resistors lose their gate drive and become open.

When the active-discharge resistor is engaged, limit its power dissipation to an average of 10mW. For example, consider the case where the active discharge resistance is discharging the output capacitor each time the regulator turns off; the 10mW limit allows discharge of 80μF of capacitance charged to 5V every 100ms (P = 1/2xCxV²/t = 1/2x80μFx5V²/100ms = 10mW).

SIMO Efficiency

Efficiency varies with inductor selection, peak inductor current, drive strength, and the ratio of input to output voltage ratio. The efficiency performance of each channel is identical (i.e., SBB0 is not more efficient than SBB1 under the same conditions). See the [Typical Operating Characteristics](#) section for a full suite of efficiency curves.

SIMO Applications Information

SIMO Available Output Current

The available output current on a given SIMO channel is a function of the input voltage, output voltage, the peak current limit setting, and the output current of the other SIMO channels. Maxim offers a [calculator](#) that outlines the available capacity for specific conditions. [Table 3](#) is an extraction from the calculator.

Table 3. SIMO Available Output Current for Common Applications

PARAMETERS	EXAMPLE 1	EXAMPLE 2	EXAMPLE 3
V.IN.MIN	2.7V	3.2V	3.4V
R.L.DCR	0.1 Ω	0.1 Ω	0.12 Ω
SBB1	1V at 100mA	1.2V at 50mA	1.2V at 20mA
SBB0	1.2V at 75mA	2.05V at 100mA	2.05V at 80mA
SBB2	1.8V at 50mA	3.3V at 30mA	3.3V at 10mA
I.PEAK.0	1A	0.866A	0.5A
I.PEAK.1	1A	0.707A	0.5A
I.PEAK.2	1A	1A	0.5A
Utilized Capacity	73%	79%	73%

($R.C.IN = R.C.OUT = 5m\Omega$, $L = 1.5\mu\text{H}$)

Inductor Selection

Choose an inductance from 1.0 μH to 2.2 μH (1.5 μH inductors is recommended for most designs). Larger inductances transfer more energy to the output for each cycle and typically result in larger output voltage ripple and better efficiency. See the [Output Capacitor Selection](#) section for more information on how to size the output capacitor in order to control ripple.

Choose the inductor saturation current to be greater than or equal to the maximum peak current limit setting that is used for all of the SIMO buck-boost channels (I_{P_SBB}). For example, if SBB0 is set for 0.5A, SBB1 is set for 0.866A, and SBB2 is set for 1.0A, then choose the saturation current to be greater than or equal to 1.0A.

Choose the RMS current rating of the inductor (typically the current at which the temperature rises appreciably) based on the expected load currents for the system.

Carefully consider the DC-resistance (DCR), AC-resistance (ACR) and physical size of the inductor. Smaller size inductors tend to have higher DCR and ACR which reduces SIMO efficiency. Inductors with low ACR in the 1MHz to 2MHz range are recommended for best efficiency.

See [Table 4](#) for examples of inductors that work well with this device. This table was created in 2016. Inductor technology advances rapidly. Always consider the most current inductor technology for new designs to achieve the best possible performance.

Table 4. Example Inductors

MANUFACTURER	PART	L (μ H)	ISAT (A)	IRMS (A)	DCR (Ω)	X (mm)	Y (mm)	Z (mm)
Samsung	CIGT201610EH2R2MN	2.2	2.9	2.7	0.073	2.0	1.6	1.0
Murata	DFE201610E-2R2M	2.2	2.6	1.9	0.117	2.0	1.6	1.0
Murata	DFE201610E-1R5M	1.5	2.4	3.2	0.076	2.0	1.6	1.0
Murata	DFE201210S-2R2M	2.2	2.3	1.80	0.127	2.0	1.2	1.0
Murata	DFE201210S-1R5M	1.5	2.2	2.6	0.086	2.0	1.2	1.0
Samsung	CIGT201208EH2R2MN	2.2	2.0	1.8	0.095	2.0	1.25	0.8
Murata	DFE201208S-1R5M	1.5	2.4	2.0	0.110	2.0	1.2	0.8
Murata	DFE201208S-2R2M	2.2	2.0	1.6	0.170	2.0	1.2	0.8

Input Capacitor Selection

Bypass IN_SBB to GND with a minimum 10 μ F ceramic capacitor (C_{IN_SBB}). Larger values of C_{IN_SBB} improve the decoupling for the SIMO regulator. C_{IN_SBB} reduces the current peaks drawn from the battery and reduces switching noise in the system. The ESR/ESL of the input capacitor should be very low (i.e., $\leq 5\text{m}\Omega$ and $\leq 500\text{pH}$) for frequencies up to 2MHz. Ceramic capacitors with X5R or X7R dielectric are highly recommended due to their small size, low ESR, and small temperature coefficients. A 6.3V capacitor voltage rating is recommended for the input voltage range of up to 5.5V.

Boost Capacitor Selection

Choose the boost capacitance (C_{BST}) to be 3.3nF. Smaller values of C_{BST} (<1nF) result in insufficient gate drive for M3. Larger values of C_{BST} (>10nF) degrade startup performance. Ceramic capacitors with 0201 or 0402 case size are recommended.

Output Capacitor Selection

Choose each output bypass capacitor (C_{SBBx}) based on the desired output voltage ripple (typically 10 μ F). Larger values of C_{SBBx} improve output voltage ripple but increase input surge current during soft-start and output voltage change. The output voltage ripple is a function of the inductor, output voltage, and peak current limit setting. Maxim offers a [calculator](#) to aid output capacitance selection. Do not exceed the maximum output capacitance as calculated by the SIMO calculator.

The impedance of the output capacitor (ESR, ESL) should be very low (i.e., $\leq 5\text{m}\Omega$ and $\leq 500\text{pH}$) for frequencies up to 2MHz. Ceramic capacitors with X5R or X7R dielectric are highly recommended due to their small size, low ESR, and small temperature coefficients. Generally, small case size capacitors derate heavily compared to larger case sizes (0603 case size performs better than 0402). Consider the effective capacitance value carefully by consulting the manufacturer's data sheet.

SIMO Switching Frequency

The SIMO buck-boost regulator utilizes a pulse frequency modulation (PFM) control scheme. The switching frequency for each output is a function of the input voltage, output voltage, load current, and inductance. For example, switching frequency increases when load is increased and decreases when inductor value is increased. Maxim offers a [SIMO Calculator](#) to help calculate the switching frequency. See [Figure 9](#) for examples of trends based on these parameters.

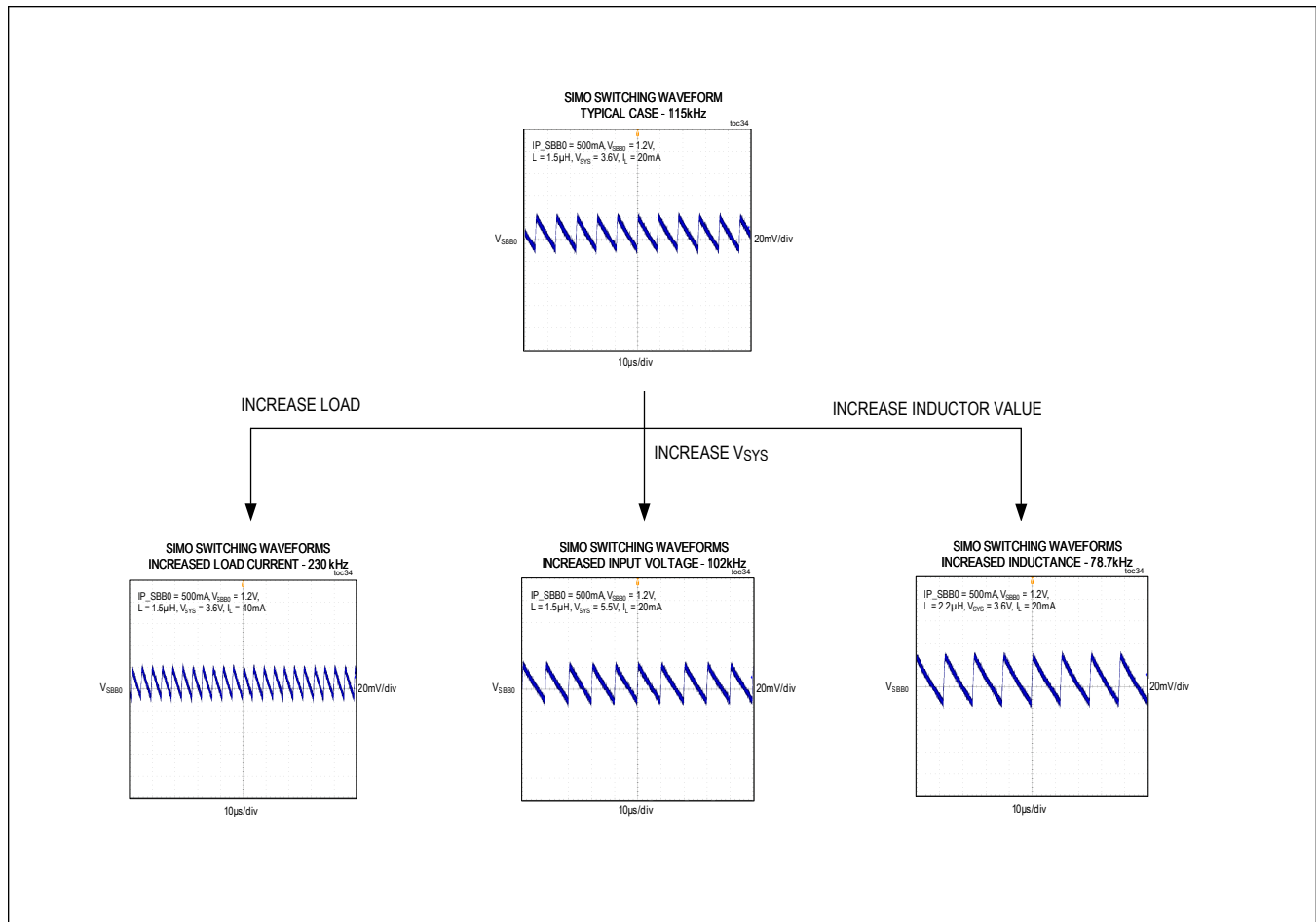

Figure 9. SIMO Switching Frequency Measurements

Unused SIMO Outputs

Do not leave unused outputs unconnected. If an output is unconnected and enabled, inductor current discharges into that unconnected pin ($\sim 50\text{nF}$ parasitic capacitance only), and the output voltage soars above the absolute maximum rating, potentially causing damage to the device. If the unused output is always disabled ($\text{EN_SBBx} = 0\text{x4}$ or 0x5), connect that output to ground. If an unused output can be enabled at any point during operation (such as startup or accidental software access), then implement one of the following:

1. Bypass the unused output with a $1\mu\text{F}$ ceramic capacitor to ground.
2. Connect the unused output to the power input (IN_SBB). This connection is beneficial because it does not require an external component for the unused output. The power input and its capacitance receives the energy packets when the regulator is enabled and $V_{\text{IN_SBB}}$ is below the target output voltage of the unused output. Circulating the energy back to the power input ensures that the unused output voltage does not fly high.
 - Note that some OTP options of the device have the active-discharge resistors enabled by default (ADE_SBBx) such that connecting an unused output SBBx to IN_SBB creates a 140Ω ($R_{\text{AD_SBBx}}$) to ground until software can be ran to disable the active-discharge resistor. **Connecting an unused SBBx to IN_SBB is not recommended if the regulator's active-discharge resistor is enabled by default.**
3. Connect the unused output to another power output that is above the target voltage of the unused output. In the same way as the option listed above, this connection is beneficial because it does not require an external

component for the unused output. Unlike the option above, this connection is preferred in cases where the unused output voltage bias level is always above the unused output voltage target because no energy packages are provided to the unused output.

- Note that some OTP options of the device have the active-discharge resistors enabled by default (ADE_SBBx). If the other power output used to bias the unused output is normally off, then the active-discharge resistor of the unused output does not create a continuous current draw. **Once the system is enabled, it should turn off the unused output's active-discharge resistor (ADE_SBBx = 0).**

PCB Layout

Use the MAX77680/MAX77681 evaluation kit ([MAX77680EVKIT#](#)) as a PCB layout reference. Good printed circuit board (PCB) layout is necessary to achieve optimal performance. The evaluation kit (EV kit) provides an example layout that optimizes its performance. PCB layouts must:

1. Minimize parasitic inductance in the SIMO input capacitor loop which is from the IN_SBB pin to the capacitor's positive terminal and from the PGND pin to the capacitor's negative terminal.
2. Minimize the parasitic inductance in the SIMO output capacitor loop which is from SBBx to the capacitor's positive terminal and from the PGND pin to the capacitor's negative terminal.
3. Use wide traces for the inductor connections in order to minimize the resistance. Do not make the traces too large. Trace width that doesn't directly lower impedance of the LX connection only increases the fringe capacitance of the LX connection to adjacent nodes and therefore increases noise coupling.

[Figure 10](#) shows an example PCB top-metal layout.

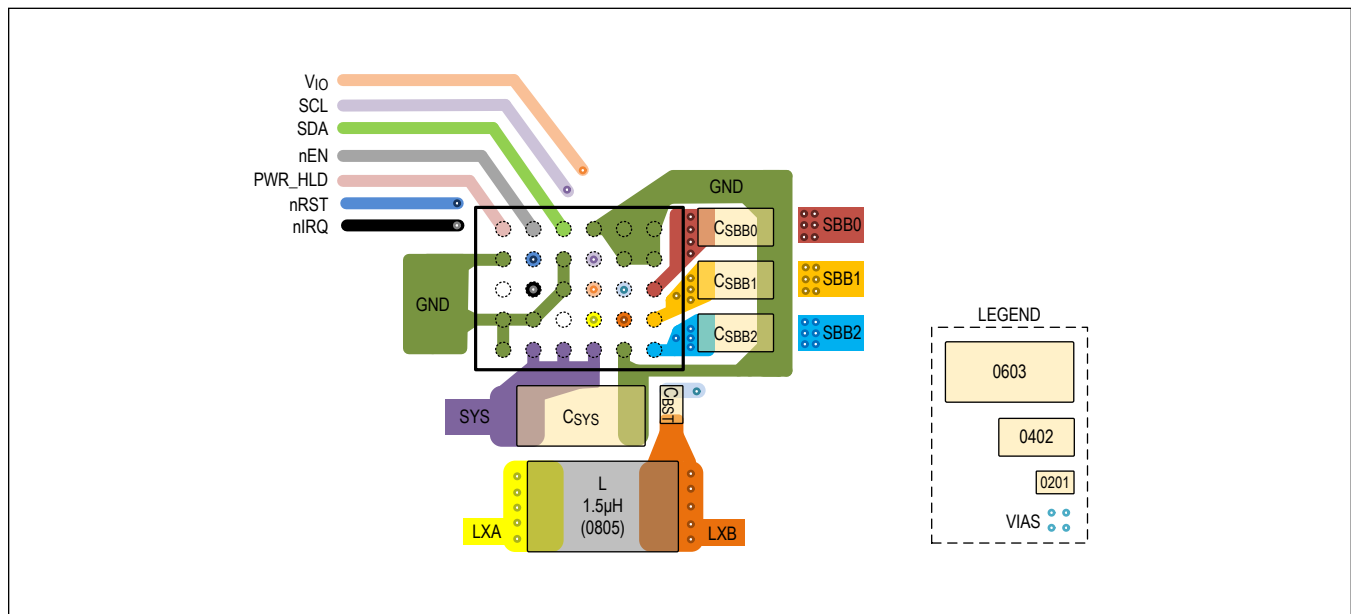

Figure 10. PCB Top-Metal and Component Layout Example

Detailed Description—I²C Serial Interface

The MAX77680/MAX77681 feature a revision 3.0 I²C-compatible, 2-wire serial interface consisting of a bidirectional serial data line (SDA) and a serial clock line (SCL). The MAX77680/MAX77681 are slave-only devices which rely on an external bus master to generate SCL. SCL clock rates from 0Hz to 3.4MHz are supported. I²C is an open-drain bus and therefore SDA and SCL require pullups.

The MAX77680/MAX77681 I²C communication controller implements 7-bit slave addressing. An I²C bus master initiates

communication with the slave by issuing a START condition followed by the slave address. The slave address is factory programmable for one of two options (Table 5). All other slave addresses not listed in Table 5 are not acknowledged.

The devices use 8-bit registers with 8-bit register addressing. They support standard communication protocols: (1) writing to a single register (2) writing to multiple sequential registers with an automatically incrementing data pointer (3) reading from a single register (4) reading from multiple sequential registers with an automatically incrementing data pointer. For additional information on the I²C protocols, refer to the [MAX77680/MAX77681 I²C-Compatible Serial Interface Implementation Guide](#) and/or the I²C specification that is freely available on the internet.

Table 5. I²C Slave Address Options

ADDRESS	7-BIT SLAVE ADDRESS	8-BIT WRITE ADDRESS	8-BIT READ ADDRESS
Main Address (ADDR = 1)*	0x48, 0b 100 1000	0x90, 0b 1001 0000	0x91, 0b 1001 0001
Main Address (ADDR = 0)*	0x40, 0b 100 0000	0x80, 0b 1000 0000	0x81, 0b 1000 0001
Test Mode**	0x49, 0b 100 1001	0x92, 0b 1001 0010	0x93, 0b 1001 0011

*Perform all reads and writes on the main address. ADDR is a factory one-time programmable (OTP) option, allowing for address changes in the event of a bus conflict. [Contact Maxim](#) for more information.

**When test mode is unlocked, the additional address is acknowledged. Test mode details are confidential. If possible, leave the test mode address unallocated to allow for the rare event that debugging needs to be performed in cooperation with Maxim.

Typical Application Circuits

SIMO Regulator using Hardware On-Key Enable

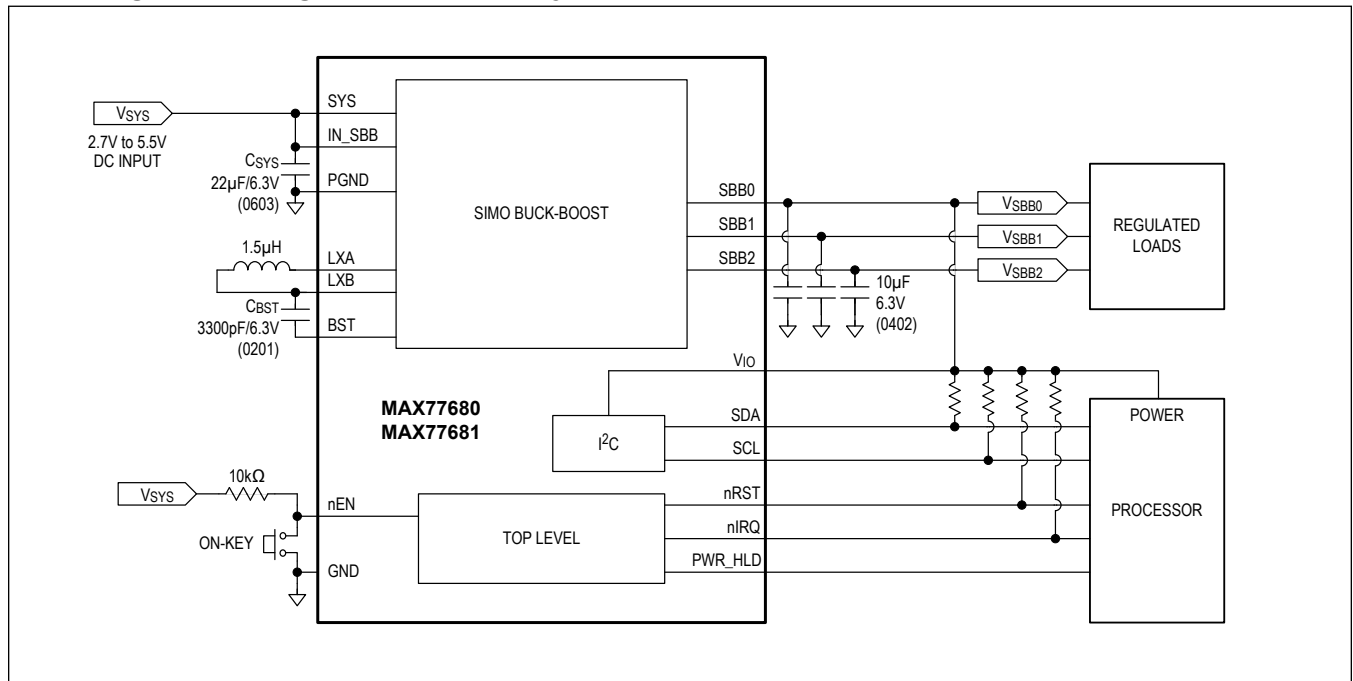

Typical Application Circuits (continued)

SIMO Regulator using Software Enable Control

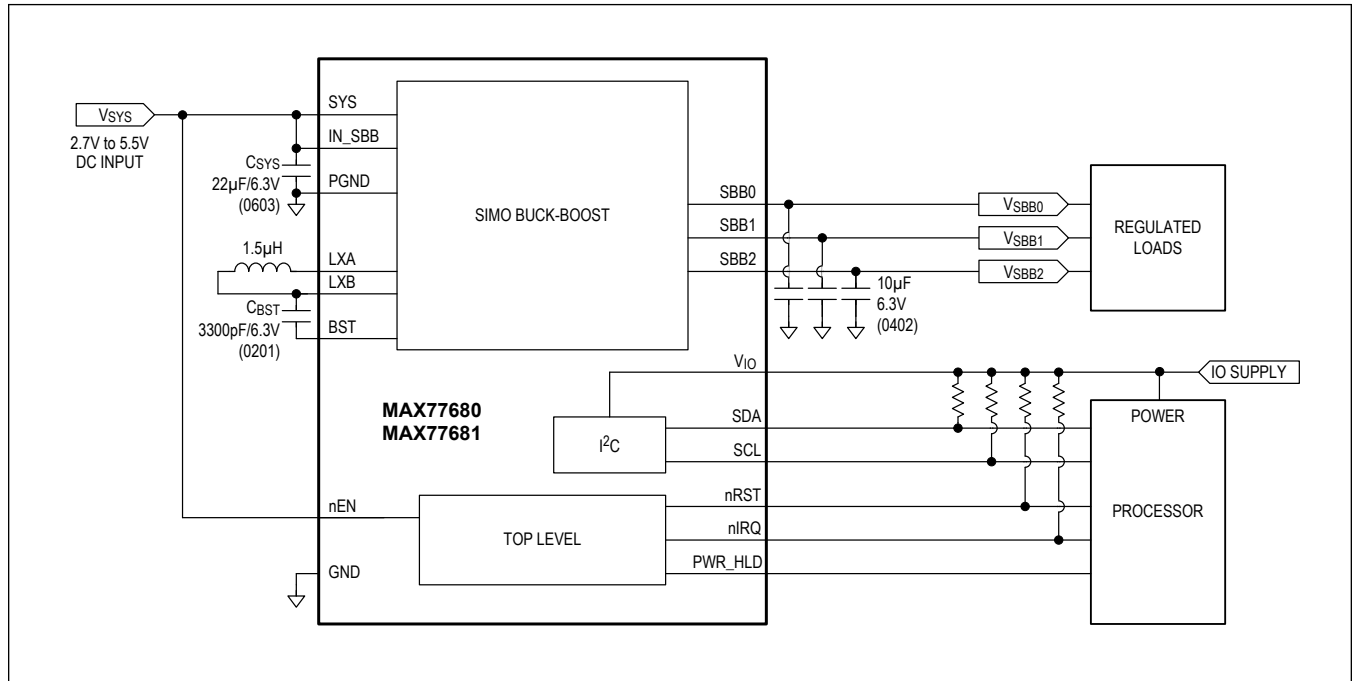

Ordering Information

PART	TEMP RANGE	PIN-PACKAGE	OPTIONS
MAX77680EWV+*	-40°C to +85°C	30 WLP	SBB0/SBB1/SBB2 upper values 2.375V/1.5875V/3.95V, samples with various OTP options
MAX77680AEWV+T	-40°C to +85°C	30 WLP	SBB0/SBB1/SBB2 upper values 2.375V/1.5875V/3.95V, production device, DIDM = 0b00, CID = 0b0000**
MAX77681EWV+*	-40°C to +85°C	30 WLP	SBB0/SBB1/SBB2 upper values 2.375V/5.25V/5.25V, samples with various OTP options
MAX77681AEWV+T	-40°C to +85°C	30 WLP	SBB0/SBB1/SBB2 upper values 2.375V/5.25V/5.25V, production device, DIDM = 0b01, CID = 0b0000**

+Denotes a lead(Pb)-free/RoHS-compliant package.

T = Tape and reel.

*Custom samples only. Not for production or stock. Contact factory for more information.

**See the [Programmer's Guide](#) document for the options associated with a specified DIDM and CID.

Revision History

REVISION NUMBER	REVISION DATE	DESCRIPTION	PAGES CHANGED
0	7/18	Initial release	—

For pricing, delivery, and ordering information, please contact Maxim Direct at 1-888-629-4642, or visit Maxim Integrated's website at www.maximintegrated.com.

Maxim Integrated cannot assume responsibility for use of any circuitry other than circuitry entirely embodied in a Maxim Integrated product. No circuit patent licenses are implied. Maxim Integrated reserves the right to change the circuitry and specifications without notice at any time. The parametric values (min and max limits) shown in the Electrical Characteristics table are guaranteed. Other parametric values quoted in this data sheet are provided for guidance.

X-ON Electronics

Largest Supplier of Electrical and Electronic Components

Click to view similar products for [Switching Voltage Regulators](#) category:

Click to view products by [Maxim](#) manufacturer:

Other Similar products are found below :

[FAN53610AUC33X](#) [FAN53611AUC123X](#) [FAN48610BUC33X](#) [FAN48610BUC45X](#) [FAN48617UC50X](#) [R3](#) [430464BB](#) [MIC45116-1YMP-T1](#) [KE177614](#) [MAX809TTR](#) [NCV891234MW50R2G](#) [NCP81103MNTXG](#) [NCP81203PMNTXG](#) [NCP81208MNTXG](#) [NCP81109GMNTXG](#) [SCY1751FCCT1G](#) [NCP81109JMNTXG](#) [AP3409ADNTR-G1](#) [LTM8064IY](#) [LT8315EFE#TRPBF](#) [NCV1077CSTBT3G](#) [XCL207A123CR-G](#) [MPM54304GMN-0002](#) [MPM54304GMN-0003](#) [XDPE132G5CG000XUMA1](#) [DA9121-B0V76](#) [LTC3644IY#PBF](#) [MP8757GL-P](#) [MIC23356YFT-TR](#) [LD8116CGL](#) [HG2269M/TR](#) [OB2269](#) [XD3526](#) [U6215A](#) [U6215B](#) [U6620S](#) [LTC3803ES6#TR](#) [LTC3803ES6#TRM](#) [LTC3412IFE](#) [LT1425IS](#) [MAX25203BATJA/VY+](#) [MAX77874CEWM+](#) [XC9236D08CER-G](#) [ISL95338IRTZ](#) [MP3416GJ-P](#) [BD9S201NUX-CE2](#) [MP5461GC-Z](#) [MPQ4415AGQB-Z](#) [MPQ4590GS-Z](#) [MCP1603-330IMC](#)