

## MAX77751

### General Description

The MAX77751 is a standalone, 3.15A charger with integrated USB Type-C® CC detection and reverse boost capability. The fast-charge current and top-off current thresholds are easily configured with resistors. The MAX77751 operates with an input voltage of 4.5V to 13.7V and has a maximum input current limit of 3A. The IC also implements the adaptive input current limit (AICL) function that regulates the input voltage by reducing input current, to prevent the voltage of a weak adapter from collapsing or folding back.

The USB Type-C Configuration Channel (CC) detection pins on the MAX77751 enable automatic USB Type C power source detection and input current limit configuration. To support a variety of legacy USB as well as proprietary adapters, the IC also integrates BC1.2 detection using the D+ and D- pins. The IC runs the CC detection and BC1.2 detection automatically without any software as soon as the USB plug is inserted.

The IC also offers Reverse-Boost capability up to 5.1V, 1.5A, which can be enabled with the ENBST pin. The STAT pin indicates charging status, while the INOKB pin indicates valid input voltage. Charging can be stopped by pulling the ITOPOFF pin low.

The MAX77751 is equipped with a Smart Power Selector™ and a battery true-disconnect FET to control the charging and discharging of the battery or isolate the battery in case of a fault. The MAX77751 is offered in several variants to support Li-ion batteries with various termination voltages from 4.1V to 4.5V. The IC comes in a 3mm x 3mm, 0.4mm pitch 24-lead FC2QFN package making it suitable for low-cost PCB assembly.

### Applications

- Mobile Point-of-Sale (mPOS) Terminals
- Portable Medical Devices
- Wireless Headphones
- GPS Trackers
- Charging Cradles for Wearable Devices
- Power Banks
- Mobile Routers

*USB Type-C is a registered trademark of USB Implementers Forum.*

*Smart Power Selector is a trademark of Maxim Integrated Products, Inc.*

## 3.15A USB-C Autonomous Charger for 1-Cell Li+ Batteries

### Benefits and Features

- Up to 16V Protection
- 13.7V Maximum Input Operating Voltage
- 3.15A Maximum Charging Current
- 6A Discharge Current Protection
- No Firmware or Communication Required
- Integrated USB Detection
  - CC Detection for USB Type-C
  - BC1.2 Detection for Legacy SDP, DCP, and CDP
  - Automatic Input Current Limit Configuration
  - Input Voltage Regulation with Adaptive Input Current Limit (AICL)
- Reverse Boost Capability up to 5.1V, 1.5A
- Pin Control of All Functions
  - Resistor-Configurable Fast-Charge Current
  - Resistor-Configurable Top-Off Current
  - ENBST Pin to Enable and Disable Reverse Boost
  - STAT Pin to Indicate Charging Status
  - INOKB Pin to Indicate Input Power-OK (POK)
  - ITOPOFF Pin to Disable Charge
- Integrated Battery True-Disconnect FET
- 3mm x 3mm, 24 Lead FC2QFN Package

**Ordering Information appears at end of data sheet.**

Simplified Block Diagram

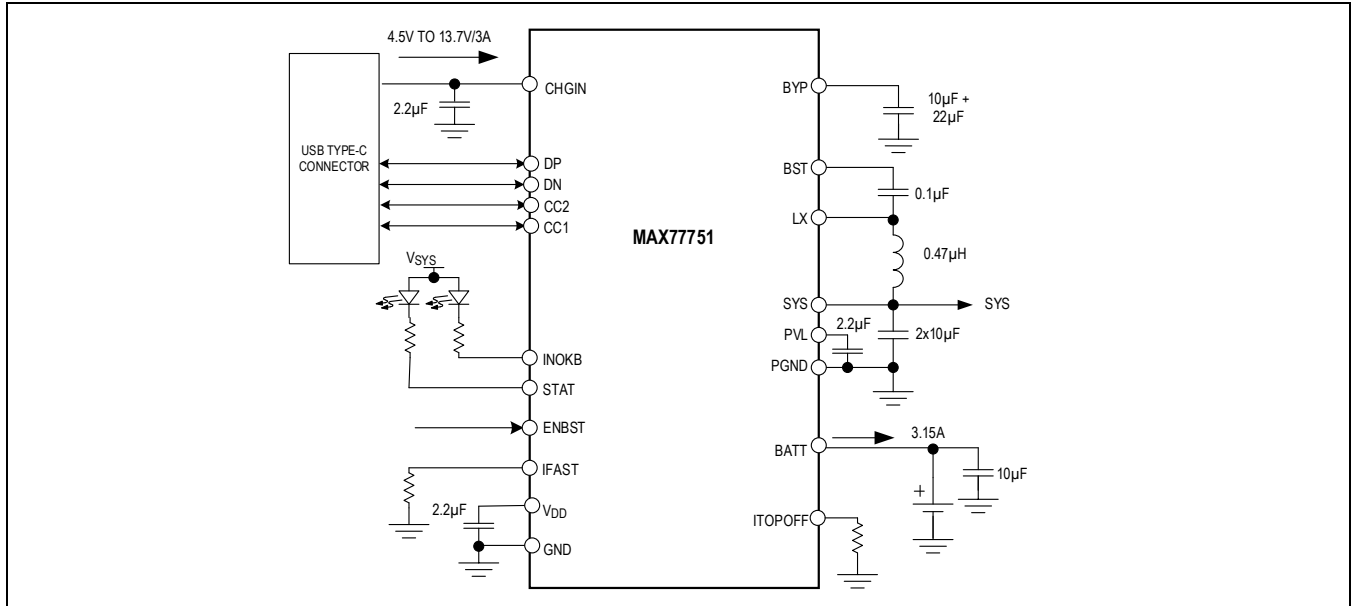

## Absolute Maximum Ratings

CHGIN to GND .....	-0.3V to +16.0V	V <sub>DD</sub> , PVL, IFAST, ITOPOFF to GND .....	-0.2V to +2.2V
BYP, LX to PGND .....	-0.3V to +16.0V	V <sub>CHGIN</sub> , BYP Continuous Current .....	3.2A <sub>RMS</sub>
BATT, SYS, INOKB, STAT, ENBST to GND .....	-0.3V to +6.0V	LX, PGND Continuous Current .....	3.5A <sub>RMS</sub>
BST to PVL .....	-0.3V to +16.0V	SYS, BATT Continuous Current .....	4.5A <sub>RMS</sub>
BST to LX .....	-0.3V to +2.2V	Operating Temperature Range .....	-40°C to +85°C
DN, DP to GND .....	-0.3V to +6.0V	Storage Temperature Range .....	-65°C to +150°C
CC1, CC2 to GND .....	-0.3V to +6.0V		

Stresses beyond those listed under "Absolute Maximum Ratings" may cause permanent damage to the device. These are stress ratings only, and functional operation of the device at these or any other conditions beyond those indicated in the operational sections of the specifications is not implied. Exposure to absolute maximum rating conditions for extended periods may affect device reliability.

## Package Information

### 24 FC2QFN

Package Code	F243A3F+1
Outline Number	<a href="#">21-100385</a>
Land Pattern Number	90-100128
<b>Thermal Resistance, Four-Layer Board:</b>	
Junction-to-Ambient ( $\theta_{JA}$ )	31°C/W
Junction-to-Case Thermal Resistance ( $\theta_{JC}$ )	7.5°C/W

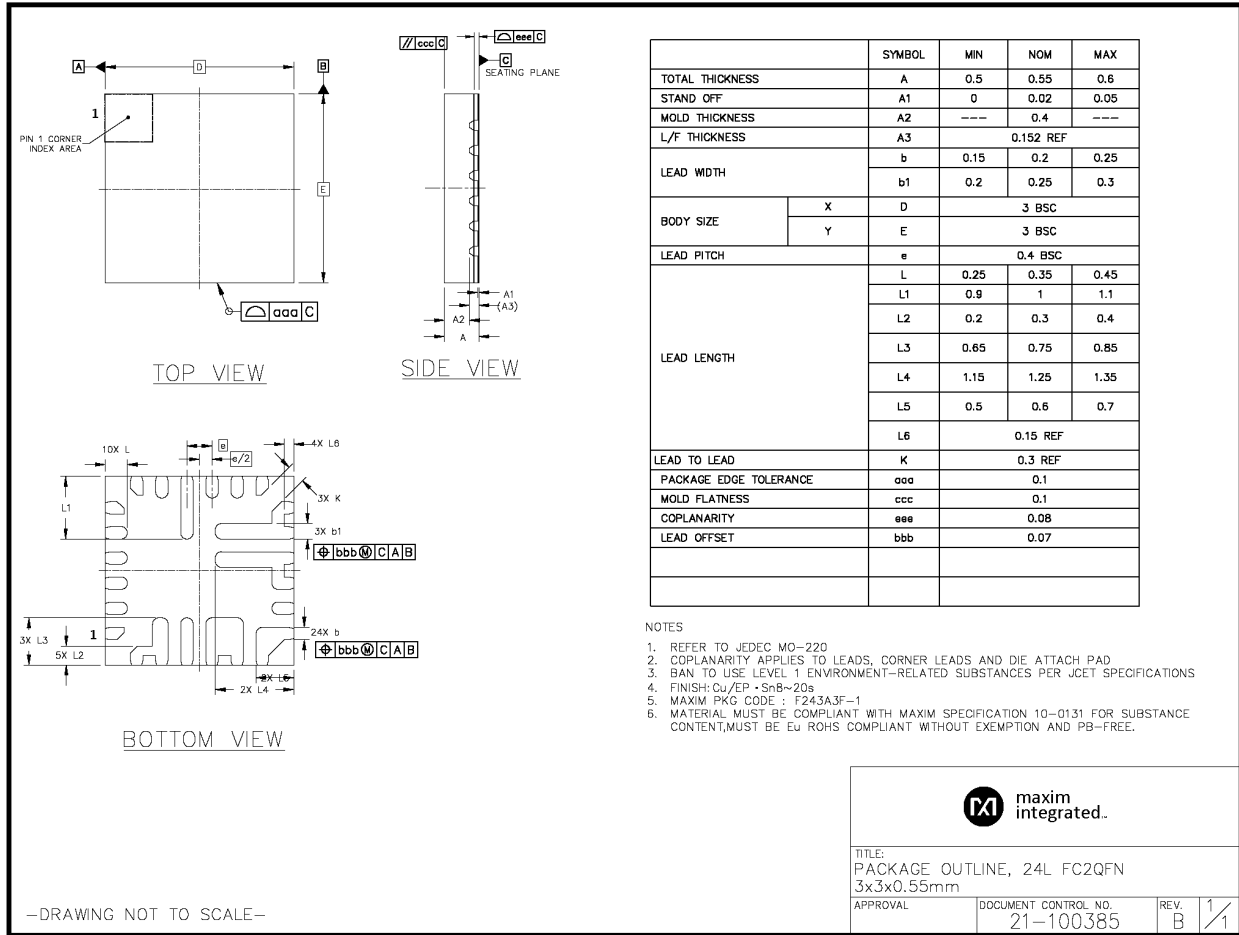

For the latest package outline information and land patterns (footprints), go to [www.maximintegrated.com/packages](http://www.maximintegrated.com/packages). Note that a "+", "#", or "-" in the package code indicates RoHS status only. Package drawings may show a different suffix character, but the drawing pertains to the package regardless of RoHS status.

Package thermal resistances were obtained using the method described in JEDEC specification JESD51-7, using a four-layer board. For detailed information on package thermal considerations, refer to [www.maximintegrated.com/thermal-tutorial](http://www.maximintegrated.com/thermal-tutorial).

## Electrical Characteristics

(Limits are 100% tested at  $T_A = +25^\circ\text{C}$ . Limits over the operating temperature range and relevant supply voltage range are guaranteed by design and characterization.)

PARAMETER	SYMBOL	CONDITIONS	MIN	TYP	MAX	UNITS
<b>GENERAL ELECTRICAL CHARACTERISTICS</b>						
Battery Only Quiescent Current	$I_{\text{BATT\_Q}}$	USB Type-C as UFP and BATT = SYS = 3.6V		30	50	$\mu\text{A}$
<b>SWITCHING MODE CHARGER</b>						
CHGIN Voltage Range	$V_{\text{CHGIN}}$	Operating voltage (Note 1)	$V_{\text{CHGIN\_UVLO}}$		$V_{\text{CHGIN\_OVLO}}$	V
CHGIN Overvoltage Threshold	$V_{\text{CHGIN\_OVLO}}$	$V_{\text{CHGIN}}$ rising	13.4	13.7	14	V
CHGIN Overvoltage Threshold Hysteresis	$V_{\text{CHGINH\_OVL}}_O$	$V_{\text{CHGIN}}$ falling		300		mV
CHGIN to GND Minimum Turn-On Threshold Accuracy	$V_{\text{CHGIN\_UVLO}}$	$V_{\text{CHGIN}}$ rising	4.6	4.7	4.8	V
CHGIN to SYS Minimum Turn-On Threshold	$V_{\text{CHGIN2SYS}}$	$V_{\text{CHGIN}}$ rising	$V_{\text{SYS}} + 0.12$	$V_{\text{SYS}} + 0.20$	$V_{\text{SYS}} + 0.28$	V
CHGIN Adaptive Voltage Regulation Threshold Accuracy	$V_{\text{CHGIN\_REG}}$		4.4	4.5	4.6	V
CHGIN Current Limit Range	$\text{CHGIN\_ILIM}$	Automatically configured after charger-type detection.	0.5		3.0	A
CHGIN Supply Current	$I_{\text{IN}}$	$V_{\text{CHGIN}} = 5.0\text{V}$ , Charger enabled, $V_{\text{SYS}} = V_{\text{BATT}} = 4.5\text{V}$ , (No switching, battery charged)		2.7	4	mA
VCHGIN Input Current Limit	$I_{\text{INLIMIT}}$	Charger enabled, 500mA input current setting, $T_A = +25^\circ\text{C}$	423	460	500	mA
		Charger enabled, 1500mA input current setting, $T_A = +25^\circ\text{C}$	1300	1400	1500	
		Charger enabled, 3000mA input current setting, $T_A = +25^\circ\text{C}$	2600	2800	3000	
CHGIN Self-Discharge Down to UVLO Time	$t_{\text{INSD}}$	Time required for the charger input to cause CHGIN capacitor to decay from 6.0V to 4.3V		100		ms
CHGIN Input Self-Discharge Resistance	$R_{\text{INSD}}$			44		k $\Omega$
CHGIN to BYP Resistance	$R_{\text{CHGIN2BYP}}$	Bidirectional		45		m $\Omega$
LX High-Side Resistance	$R_{\text{HS}}$			60		m $\Omega$
LX Low-Side Resistance	$R_{\text{LS}}$			60		m $\Omega$
BATT to SYS Dropout Resistance	$R_{\text{BAT2SYS}}$			20		m $\Omega$
CHGIN to BATT Dropout Resistance	$R_{\text{CHGIN2BAT}}$	Calculation estimates a 0.04 $\Omega$ inductor resistance ( $R_L$ ). $R_{\text{CHGIN2BAT}} = R_{\text{CHGIN2BYP}} + R_{\text{HS}} + R_L + R_{\text{BAT2SYS}}$		165		m $\Omega$
LX Leakage Current		LX = PGND or BYP, $T_A = +25^\circ\text{C}$		0.01	10	$\mu\text{A}$

(Limits are 100% tested at  $T_A = +25^\circ\text{C}$ . Limits over the operating temperature range and relevant supply voltage range are guaranteed by design and characterization.)

PARAMETER	SYMBOL	CONDITIONS	MIN	TYP	MAX	UNITS
		LX = PGND or BYP, $T_A = +85^\circ\text{C}$		1		
BST Leakage Current		BST = PGND or 1.8V, $T_A = +25^\circ\text{C}$		0.01	10	$\mu\text{A}$
		BST = PGND or 1.8V, $T_A = +85^\circ\text{C}$		1		
BYP Leakage Current		$V_{\text{BYP}} = 5\text{V}$ , $V_{\text{CHGIN}} = 0\text{V}$ , LX = 0V, charger disabled, $T_A = +25^\circ\text{C}$		0.01	10	$\mu\text{A}$
		$V_{\text{BYP}} = 5\text{V}$ , $V_{\text{CHGIN}} = 0\text{V}$ , LX = 0V, charger disabled, $T_A = +85^\circ\text{C}$		1		
SYS Leakage Current		$V_{\text{SYS}} = 0\text{V}$ , $V_{\text{BATT}} = 4.2\text{V}$ , charger disabled, $T_A = +25^\circ\text{C}$		0.01	10	$\mu\text{A}$
		$V_{\text{SYS}} = 0\text{V}$ , $V_{\text{BATT}} = 4.2\text{V}$ , charger disabled, $T_A = +85^\circ\text{C}$		1		
Minimum ON Time	$t_{\text{ON-MIN}}$			75		ns
Minimum OFF Time	$t_{\text{OFF-MIN}}$			75		ns
Buck Current Limit	$I_{\text{LIM}}$		5.16	6.0	6.84	A
Reverse Boost Quiescent Current		Non-switching: output forced 200mV above its target regulation voltage		2000		$\mu\text{A}$
Reverse Boost BYP Voltage in OTG Mode	$V_{\text{BYP.OTG}}$		4.94	5.1	5.26	V
CHGIN Output Current Limit	$I_{\text{CHGIN.OTG.LIM}}$	$3.4\text{V} < V_{\text{BATT}} < 4.5\text{V}$ , $T_A = +25^\circ\text{C}$	1500		1725	mA
Reverse Boost Output Voltage Ripple		Discontinuous inductor current (i.e., skip mode)		$\pm 150$		mV
		Continuous inductor current		$\pm 150$		
BATT Regulation Voltage Accuracy		$T_A = +25^\circ\text{C}$ , BATT regulation voltage (See the Ordering Information table)	-0.9	-0.3	+0.3	%
		$T_A = 0^\circ\text{C}$ to $+85^\circ\text{C}$ , BATT regulation voltage (See the Ordering Information table)	-1	-0.3	+0.5	
Fast-Charge Current Program Range		External resistor programmable	0.5		3.15	A
Fast-Charge Currents	$I_{\text{FC}}$	$T_A = +25^\circ\text{C}$ , $V_{\text{BATT}} > V_{\text{SYSMIN}}$ , programmed for 3.0A	2850	3000	3150	mA
		$T_A = +25^\circ\text{C}$ , $V_{\text{BATT}} > V_{\text{SYSMIN}}$ , programmed for 2.0A	1900	2000	2100	
		$T_A = +25^\circ\text{C}$ , $V_{\text{BATT}} > V_{\text{SYSMIN}}$ , programmed for 0.5A	465	500	535	
Trickle Charge Threshold	$V_{\text{TRICKLE}}$	$V_{\text{BATT}}$ rising	3.0	3.1	3.2	V
Precharge Threshold	$V_{\text{PRECHG}}$	$V_{\text{BATT}}$ rising	2.4	2.5	2.6	V
Prequalification Threshold Hysteresis	$V_{\text{PQ-H}}$	Applies to both $V_{\text{TRICKLE}}$ and $V_{\text{PRECHG}}$		100		mV
Trickle Charge Current	$I_{\text{TRICKLE}}$		270	300	330	mA
Precharge Charge Current	$I_{\text{PRECHG}}$		40	55	80	mA
Charger Restart Threshold	$V_{\text{RSTRT}}$		50	100	150	mV

(Limits are 100% tested at  $T_A = +25^\circ\text{C}$ . Limits over the operating temperature range and relevant supply voltage range are guaranteed by design and characterization.)

PARAMETER	SYMBOL	CONDITIONS	MIN	TYP	MAX	UNITS
Charger Restart Deglitch Time		10mV overdrive, 100ns rise time		130		ms
Charger Enable Threshold	$V_{\text{CHGR\_EN}}$		295.2	367.7	439.7	mV
Top-Off Current Program Range	$I_{\text{TO}}$	Resistor programmable from 100mA to 350mA	100		350	mA
Top-Off Current Accuracy		Gain			5	%
		Offset			20	mA
Charge Termination Deglitch Time	$t_{\text{TERM}}$	2mV overdrive, 100ns rise/fall time		30		ms
Charger Soft Start Time	$t_{\text{SS}}$			1.5		ms
BATT to SYS Reverse Regulation Voltage	$V_{\text{BSREG}}$	$I_{\text{BATT}} = 10\text{mA}$		70		mV
		Load regulation during the reverse regulation mode		1		mV/A
Minimum SYS Voltage	$V_{\text{SYSMIN}}$			3.5		V
Minimum SYS Voltage Accuracy	$V_{\text{SYSMIN}}$		-3		+3	%
Prequalification Time	$t_{\text{PQ}}$	Applies to both low-battery precharge and trickle modes		30		min
Fast-Charge Constant Current Plus Fast-Charge Constant Voltage Time	$t_{\text{FC}}$			6		hours
Top-Off Time	$t_{\text{TO}}$			30		s
Timer Accuracy			-20		+20	%
Junction Temperature Thermal Regulation Loop Setpoint Program Range	$T_{\text{REG}}$	Junction temperature when charge current is reduced		130		$^\circ\text{C}$
Thermal Regulation Gain	$AT_{\text{JREG}}$	$I_{\text{FC}} = 3.15\text{A}$		-157.5		$\text{mA}/^\circ\text{C}$
Battery Overcurrent Threshold	$I_{\text{BOVCR}}$			6.0		A
Battery Overcurrent Debounce Time	$t_{\text{BOVRC}}$		6			ms
Battery Overcurrent Retry	$t_{\text{OCP\_RETRY}}$			0.15		sec
Battery Overcurrent Protection Quiescent Current	$I_{\text{BOVRC}}$			3 + $I_{\text{BATT}}/18040$		$\mu\text{A}$
System Power-Up Current	$I_{\text{SYSPU}}$		35	50	80	mA
System Power-Up Voltage	$V_{\text{SYSPU}}$	$V_{\text{SYS}}$ rising, 100mV hysteresis	1.9	2.0	2.1	V
<b>INOKB, STAT</b>						
Logic Input Leakage Current				0.1	1	$\mu\text{A}$

(Limits are 100% tested at  $T_A = +25^\circ\text{C}$ . Limits over the operating temperature range and relevant supply voltage range are guaranteed by design and characterization.)

PARAMETER	SYMBOL	CONDITIONS	MIN	TYP	MAX	UNITS
Output Low Voltage INOKB, STAT		$I_{\text{SOURCE}} = 5\text{mA}$ , $T_A = +25^\circ\text{C}$			0.4	V
Output High Leakage INOKB, STAT		$V_{\text{SYS}} = 5.5\text{V}$ , $T_A = +25^\circ\text{C}$	-1	0	+1	$\mu\text{A}$
		$V_{\text{SYS}} = 5.5\text{V}$ , $T_A = +85^\circ\text{C}$		0.1		
<b>ENBST</b>						
ENBST Logic Input Low Threshold	$V_{\text{IL}}$				0.4	V
ENBST Logic Input High Threshold	$V_{\text{IH}}$		1.4			V
ENBST Logic Input Leakage Current	$I_{\text{ENBST}}$	ENBST = 5.5V (including current through pulldown resistor)		24	60	$\mu\text{A}$
ENBST Pulldown Resistor	$R_{\text{ENBST}}$			235		$\text{k}\Omega$
<b>CHARGER DETECTION</b>						
BC1.2 State Timeout	$t_{\text{TMO}}$		180	200	220	ms
Data Contact Detect Timeout	$t_{\text{DCDtm0}}$		700	800	900	ms
Proprietary Charger Debounce	$t_{\text{PRDeb}}$		5	7.5	10	ms
Primary-to-Secondary Timer	$t_{\text{PDSWait}}$		27	35	39	ms
Charger Detection Debounce	$t_{\text{CDDeb}}$		45	50	55	ms
VBUS64 Threshold	$V_{\text{BUS64}}$	DP and DN pins. Threshold in percent of $V_{\text{BUS}}$ voltage. $3\text{V} < V_{\text{BUS}} < 5.5\text{V}$	57	64	71	%
VBUS64 Hysteresis	$V_{\text{BUS64\_H}}$			0.015		V
VBUS47 Threshold	$V_{\text{BUS47}}$	DP and DN pins. Threshold in percent of $V_{\text{BUS}}$ voltage. $3\text{V} < V_{\text{BUS}} < 5.5\text{V}$	43.3	47	51.7	%
VBUS47 Hysteresis				0.015		V
VBUS31 Threshold	$V_{\text{BUS31}}$	DP and DN pins. Threshold in percent of $V_{\text{BUS}}$ voltage. $3\text{V} < V_{\text{BUS}} < 5.5\text{V}$	26	31	36	%
VBUS31 Hysteresis				0.015		V
IWEAK Current	$I_{\text{WEAK}}$		0.01	0.1	0.5	$\mu\text{A}$
RDM_DWN Resistor	$R_{\text{DM\_DWN}}$		14.25	20	24.8	$\text{k}\Omega$
IDP_SRC Current	$I_{\text{DP\_SRC}}/I_{\text{DCD}}$	Accurate over 0V to 2.5V	7	10	13	$\mu\text{A}$
IDM_SINK Current	$I_{\text{DM\_SINK}}/I_{\text{DAT\_SINK}}$	Accurate over 0.15V to 3.6V	45	80	125	$\mu\text{A}$
VLGC Threshold	$V_{\text{LGC}}$		1.62	1.7	1.9	V
VLGC Hysteresis	$V_{\text{LGC\_H}}$			0.015		V
VDAT_REF Threshold	$V_{\text{DAT\_REF}}$		0.25	0.32	0.4	V
VDAT_REF Hysteresis	$V_{\text{DAT\_REF\_H}}$			0.015		V
VDN_SRC Voltage	$V_{\text{DN\_SRC}}/V_{\text{SR\_C06}}$	Accurate over $I_{\text{LOAD}} = 0$ to $200\mu\text{A}$	0.5	0.6	0.7	V
VDP_SRC Voltage	$V_{\text{DP\_SRC}}/V_{\text{SR\_C06}}$	Accurate over $I_{\text{LOAD}} = 0$ to $200\mu\text{A}$	0.5	0.6	0.7	V



(Limits are 100% tested at  $T_A = +25^\circ\text{C}$ . Limits over the operating temperature range and relevant supply voltage range are guaranteed by design and characterization.)

PARAMETER	SYMBOL	CONDITIONS	MIN	TYP	MAX	UNITS
COMP2 Load Resistor	$R_{USB}$	Load Resistor on DP/DN	3	6.1	12	$M\Omega$
<b>CC DETECTION</b>						
CC Pin Voltage, in DFP 1.5A Mode	$V_{CC\_PIN}$	Measured at CC pins with 126k $\Omega$ load. IDFP1.5_CC enable and $V_{AVL} \geq 2.5\text{V}$	1.85			V
CC Pin Clamp Voltage	$V_{CC\_CLAMP}$	$60\mu\text{A} \leq I_{CC\_} \leq 600\mu\text{A}$		1.1	1.32	V
CC Pin Clamp Voltage (5.5V)		$I_{CC\_} < 2\text{mA}$		5.25	5.5	V
CC UFP Pulldown Resistance	$R_{PD\_UFP}$		-10%	5.1K	+10%	$\Omega$
CC DFP 1.5A Current Source	$I_{DFP1.5\_CC}$		-8%	180	+8%	$\mu\text{A}$
CC RA RD Threshold	$V_{RA\_RD0.5}$		0.15	0.2	0.25	V
CC UFP 0.5A RD Threshold	$V_{UFP\_RD0.5}$		0.61	0.66	0.7	V
CC UFP 0.5A RD Hysteresis	$V_{UFP\_RD0.5\_H}$			0.015		V
CC UFP 1.5A RD Threshold	$V_{UFP\_RD1.5}$		1.16	1.23	1.31	V
CC UFP 1.5A RD Hysteresis	$V_{UFP\_RD1.5\_H}$			0.15		V
CC Pin Power Up Time	$t_{ClampSwap}$	Max time allowed from removal of voltage clamp until 5.1k $\Omega$ resistor is attached			15	ms
CC Detection Debounce	$t_{CCDeb}$		100	119	200	ms
USB Type-C Debounce	$t_{PDDeb}$		10	15	20	ms
USB Type-C Quick Debounce	$t_{QDeb}$		0.9	1	1.1	ms

**Note 1:** The CHGIN input must be less than  $V_{CHGIN\_OVLO}$  and greater than both  $V_{CHGIN\_UVLO}$  and  $V_{CHGIN2SYS}$  for the charger to turn on.

Typical Operating Characteristics

( $V_{CHGIN} = 5V$ ,  $V_{BATT} = 3.8V$ ,  $T_A = +25^\circ C$ , unless otherwise noted.)

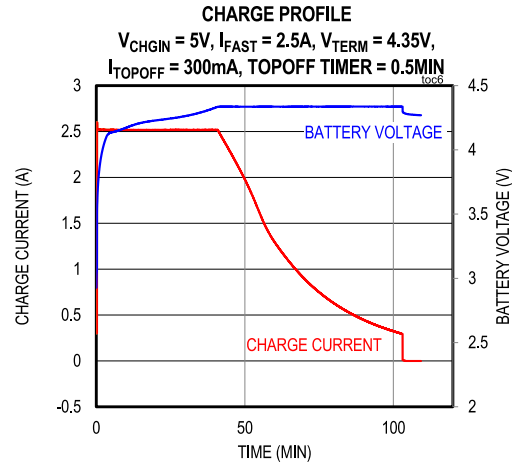
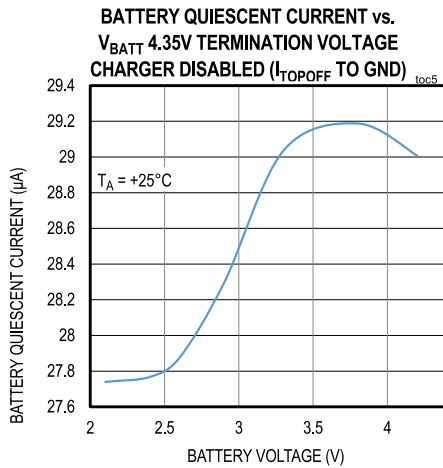
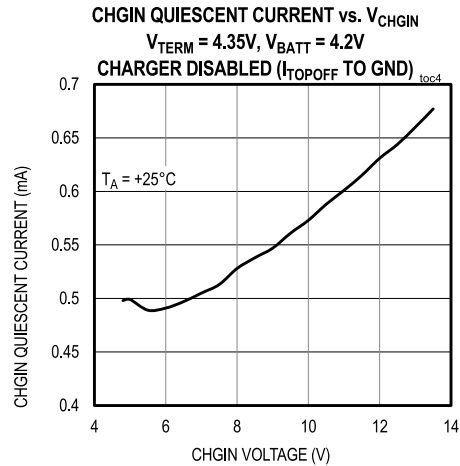
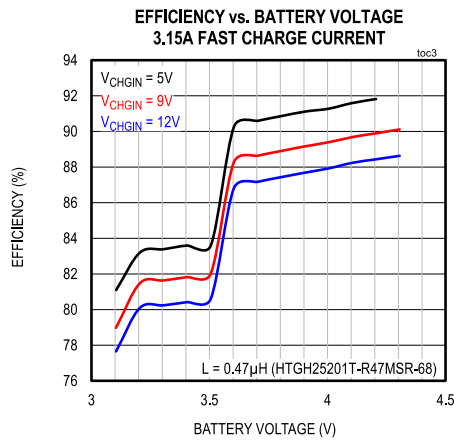
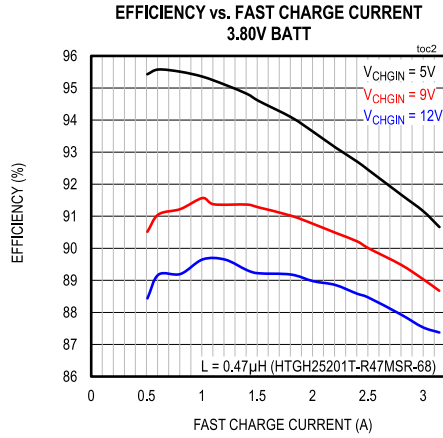
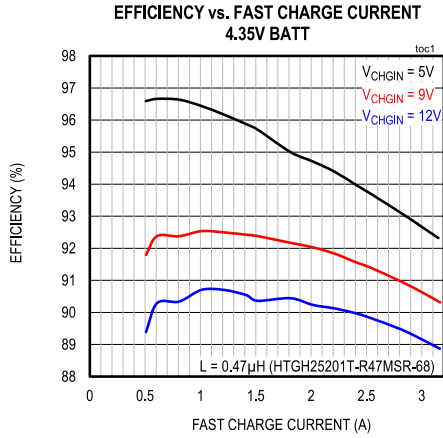

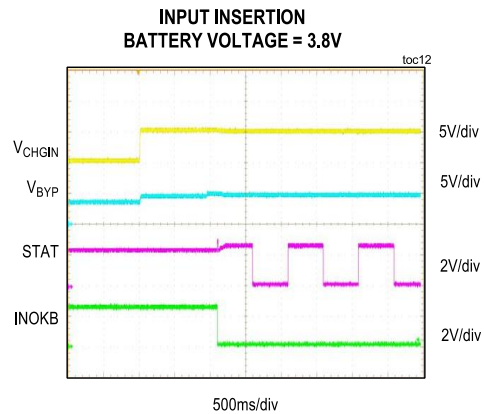
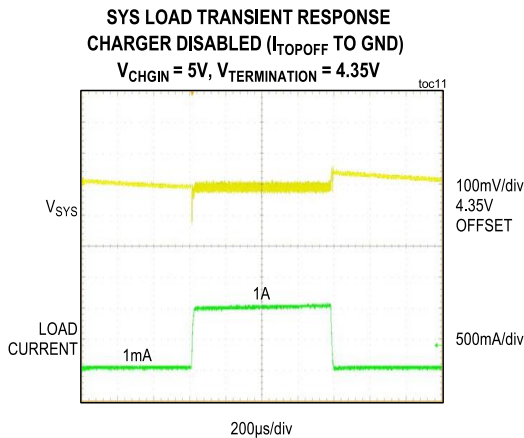
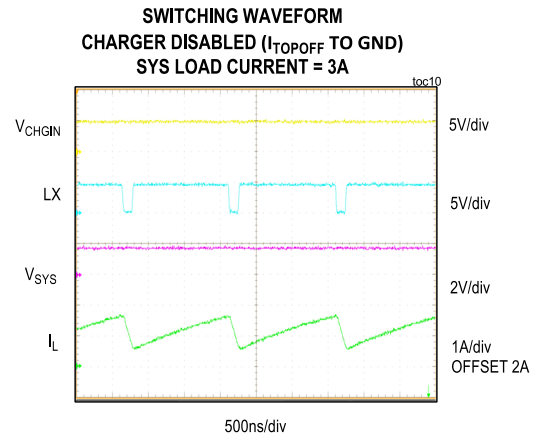
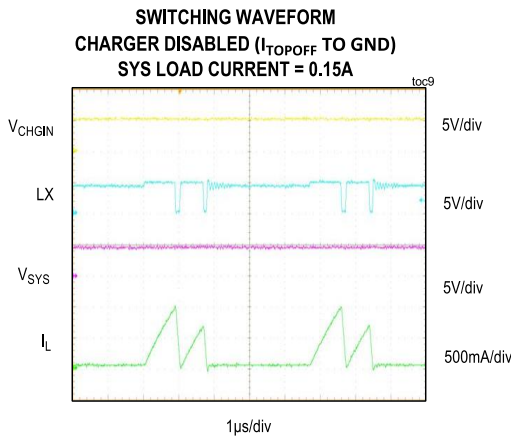
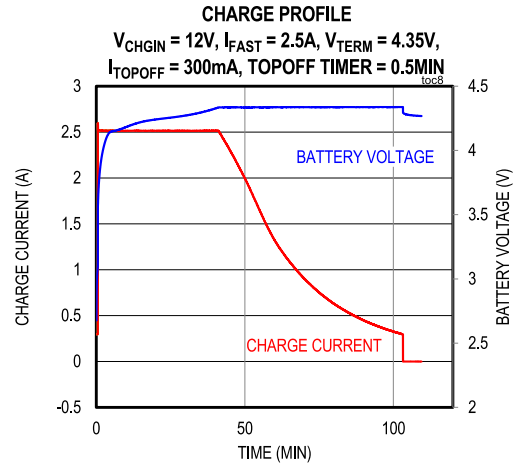
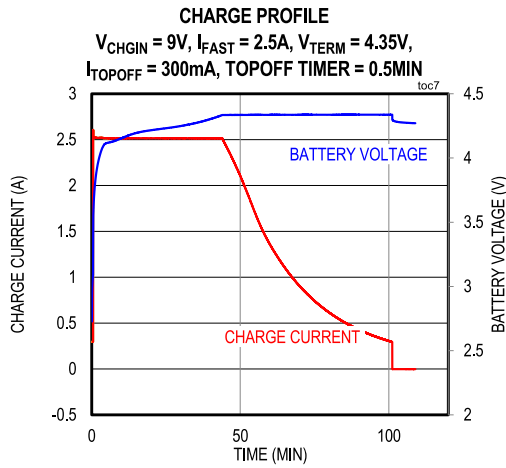

**INPUT DISCONNECT**  
BATTERY VOLTAGE = 3.8V

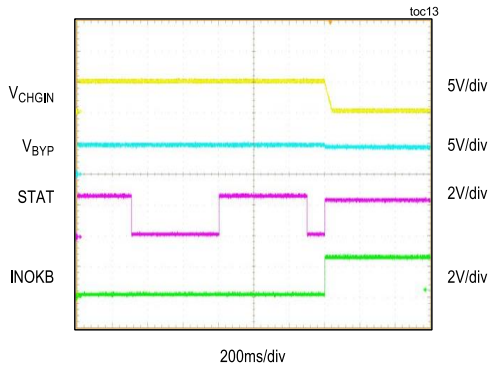

**OTG EFFICIENCY vs. OTG LOAD CURRENT**

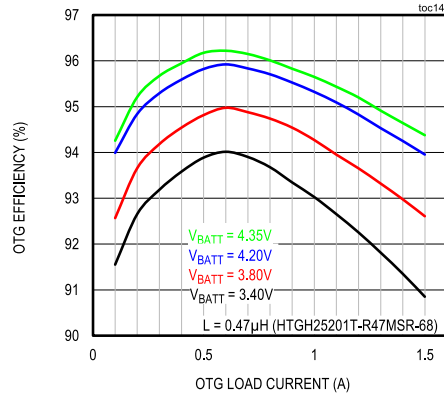

**OTG OUTPUT VOLTAGE vs. OTG LOAD CURRENT**

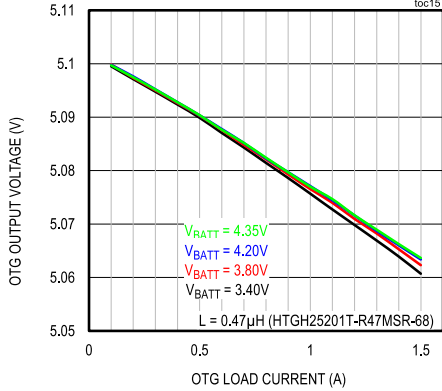

**OTG ENABLE**

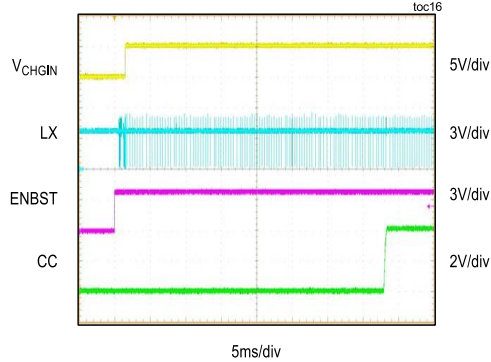

**OTG DISABLE**  
OTG LOAD CURRENT = 1A

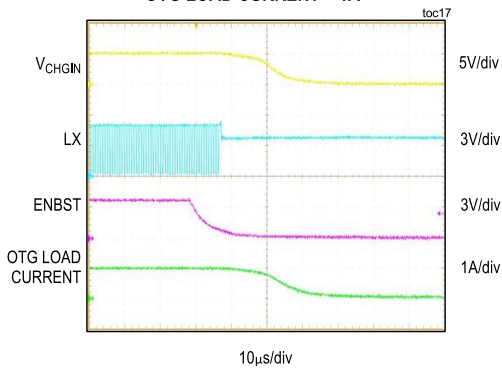

**BOOST SWITCHING WAVEFORM**  
OTG LOAD CURRENT = 0.15A

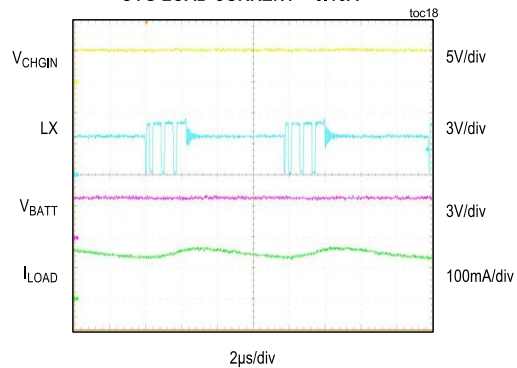

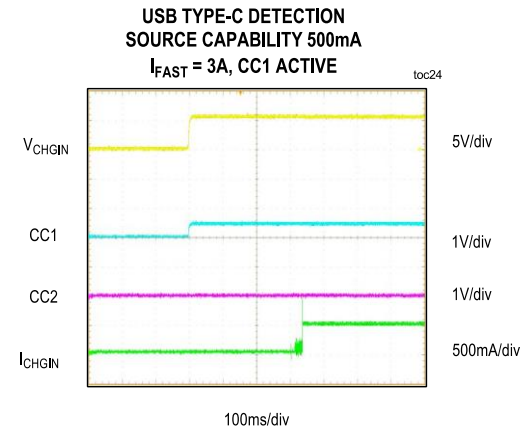
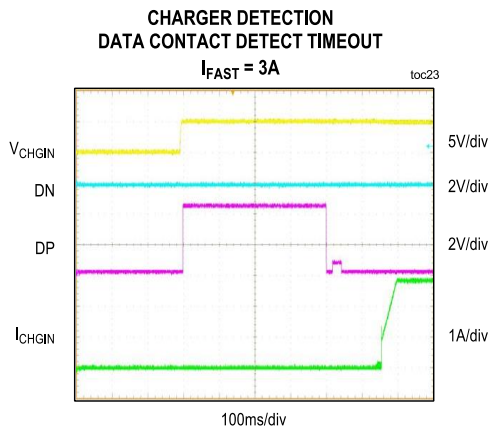
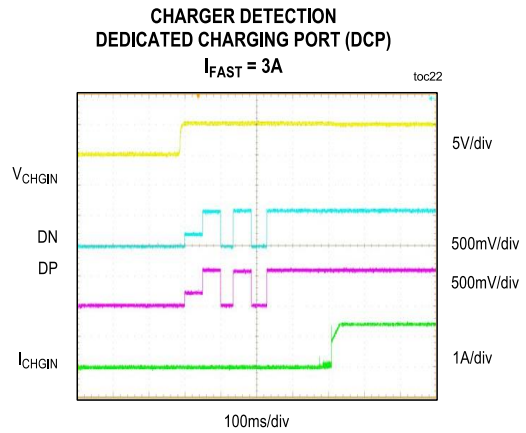
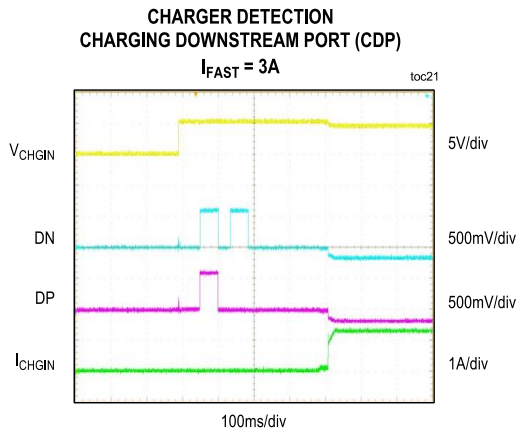
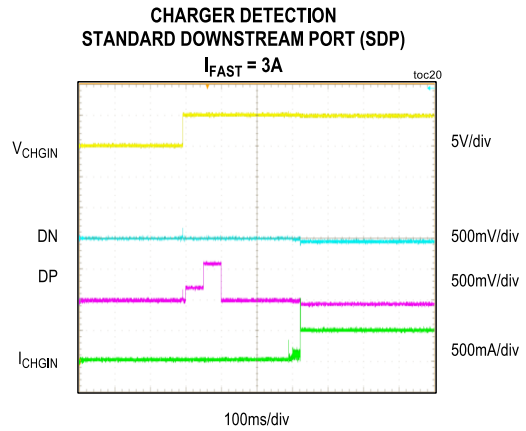
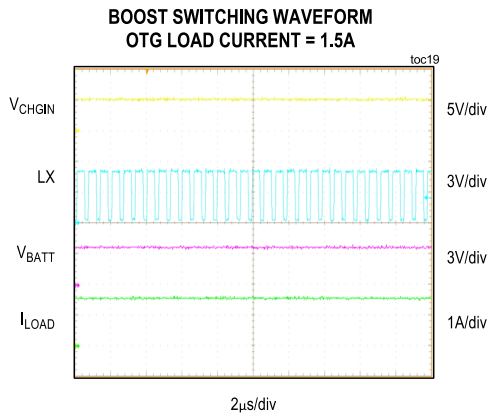

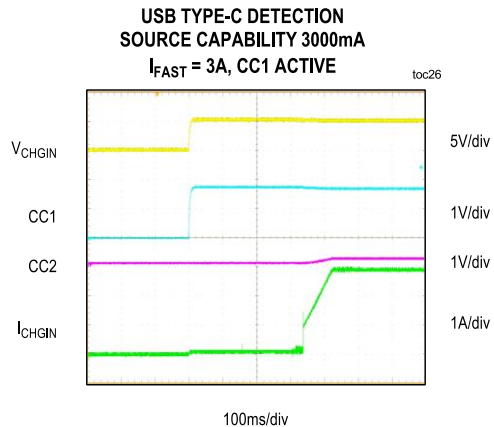
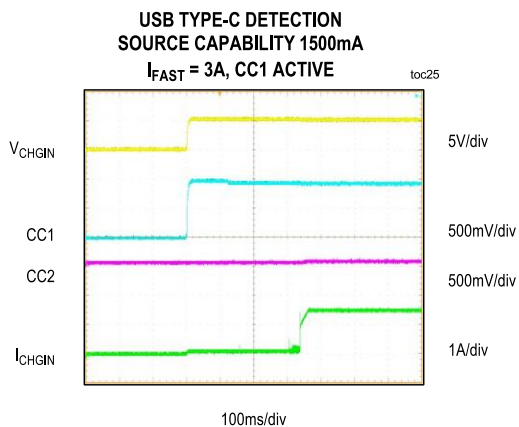

## Pin Configurations

## FC2QFN

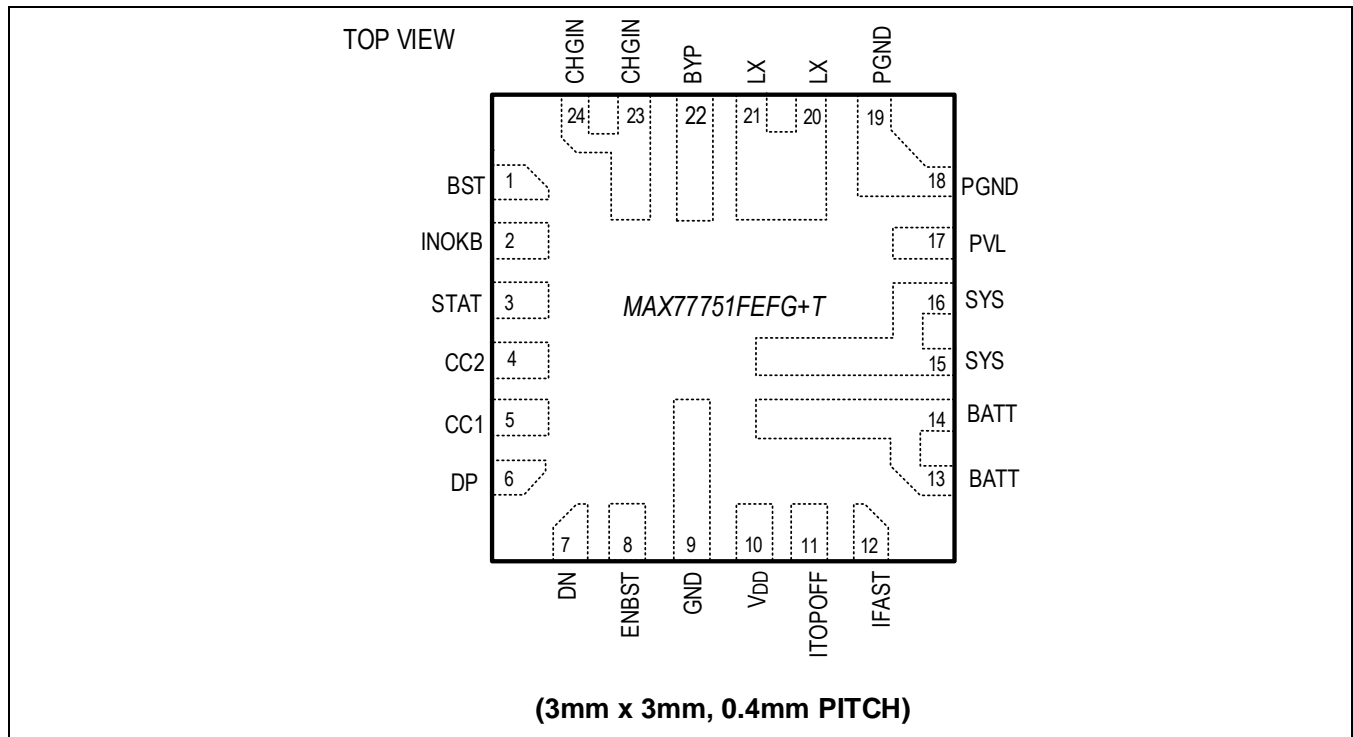

## Pin Descriptions

PIN	NAME	FUNCTION
1	BST	Provides Drive to High-Side Internal nMOS. Connect a 100nF/6.3V bootstrap capacitor between this pin and the LX node.
2	INOKB	Charger Input Valid, Active Low Logic Output Flag. Open-drain output indicates when valid voltage is present at CHGIN.
3	STAT	Open Drain Charge Status Indication Output. STAT toggles low and high impedance during charge. STAT becomes low when top-off threshold is detected and in done state. STAT becomes high impedance when charge faults occur.
4	CC2	USB Type-C CC2 Connection
5	CC1	USB Type-C CC1 Connection
6	DP	Common Positive Output 1. Connect to D+ on USB Type-C or micro USB connector.
7	DN	Common Negative Output 1. Connect to D- on USB Type-C or micro USB connector.
8	ENBST	Active High Logic Input. Enable/Disable the Reverse Boost Converter
9	GND	Analog Ground. Short to ground plane.
10	V <sub>DD</sub>	Output of On-Chip LDO Used to Power On-Chip, Low-Noise Circuits. Bypass with a 2.2μF/10V ceramic capacitor to GND. Powering external loads from VDD is not recommended other than pullup resistors.
11	ITOPOFF	Top Off Current Setting Pin. Connect a resistor (RTOPOFF) from ITOPOFF to GND to program the top-off current from 100mA to 350mA. Use 8.06kΩ for 100mA top-off current. The pin is also used to enable or disable the charger. See the <a href="#">Application Information</a> section.
12	IFAST	Fast Charge Current Setting Pin. Connect a resistor (RIFAST) from IFAST to GND to program the fast charge current. Use 24.9kΩ for 3.15A fast charge current. See the <a href="#">Application Information</a> section.

13, 14	BATT	Battery Power Connection. Connect to the positive terminal of a single-cell (or parallel cell) Li-ion battery. Bypass BATT to PGND ground plane with a 10µF ceramic capacitor.
15, 16	SYS	System Power Node. Bypass SYS to PGND with a 2x10µF/10V ceramic capacitor.
17	PVL	Output of On-Chip LDO, Noisy Rail Due to Bootstrap Operation. Bypass with a 2.2µF/10V ceramic capacitor to PGND. Powering external loads from PVL is not recommended.
18, 19	PGND	Power Ground. Connect the return of the buck output capacitor close to these pins.
20, 21	LX	Switching Node. Connect an inductor between LX and SYS. When the buck converter is enabled, LX switches between BYP and PGND to control the input current, battery current, battery voltage, and die temperature.
22	BYP	System Power Connection. Output of OVP adapter input block and input to switching charger. Bypass with 22µF/16V ceramic capacitor from BYP to PGND.
23, 24	CHGIN	Charger Input. Up to 13.7V operating, 16VDC withstand input pin connected to an adapter or USB power source. Connect a 2.2µF/16V ceramic capacitor from CHGIN to GND.

Functional Diagram

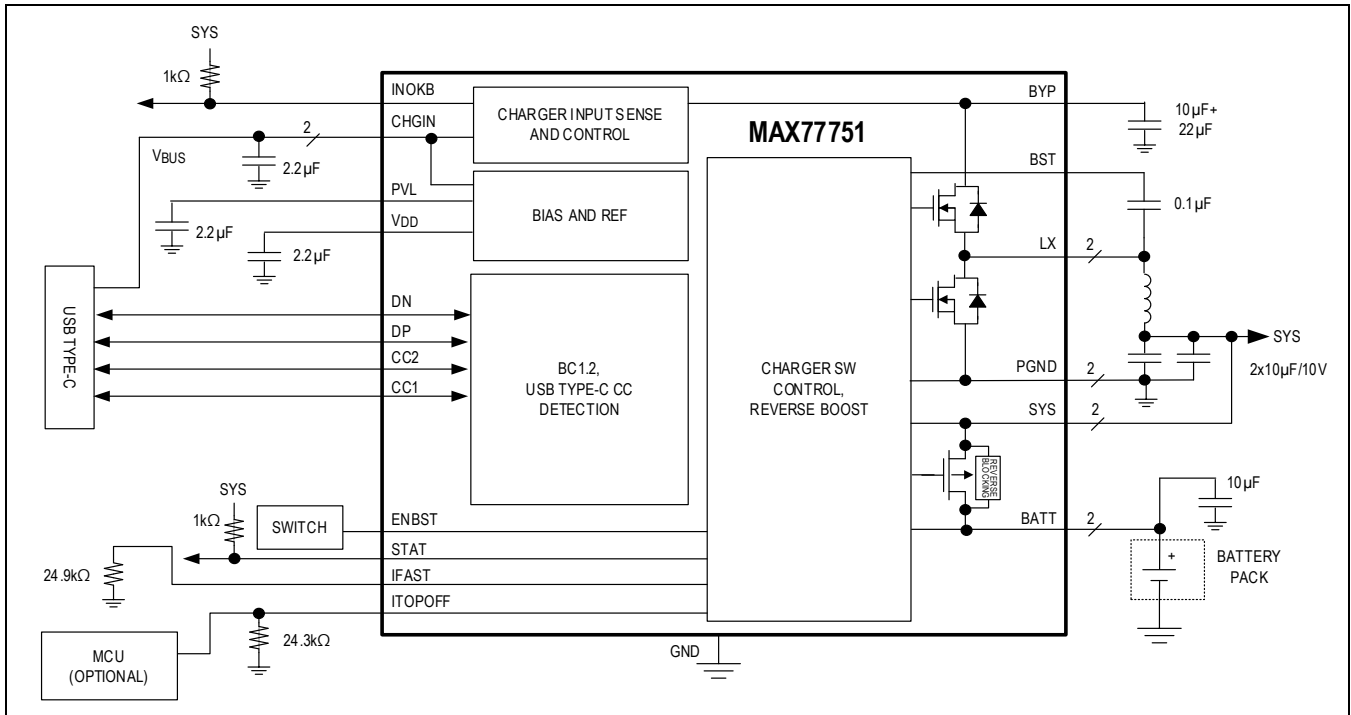



## Detailed Description

The MAX77751 is a highly integrated USB Type-C Charger with autonomous configuration. The MAX77751 can operate at an input range from 4.5V to 13.7V to support a 5V, 9V, and 12V AC adapter and USB input. It is capable of supplying a fast-charge current up to 3.15A and the maximum input current limit is 3.0A.

The MAX77751 can run BC1.2 and USB Type-C CC detection when USB input is plugged in and can configure the input source to the maximum power option and the charger input current limit to maximum power.

The fast-charge current and top-off current threshold can be programmed with an external resistor. The input voltage regulation feature with adaptive input current limit (AICL) allows charging to continue even with a weak adapter by preventing it from collapsing or folding back.

The power path design provides system power even when the battery is fully discharged, and it supplements current from the battery and CHGIN input automatically when the system demands higher current.

Reverse boost from the battery can be enabled by the ENBST pin to allow 5.1V/1.5A OTG to  $V_{BUS}$ .

## Switching Mode Charger

### Features

- Complete Li-ion/Li-Polymer Switching Charger
  - Prequalification, Constant Current, Constant Voltage Charging
  - 55mA Precharge, 300mA Trickle Charge Current
  - 500mA to 3.15A Resistor-Adjustable Fast-Charge Current
  - 100mA to 350mA Resistor-Adjustable Charge Termination Threshold
  - 4.1V to 4.5V Battery Regulation Voltage (see the [Ordering Information](#) section)
- Smart Power Selector
  - Optimally Distributes Power Between the Charge Adapter, System, and Battery
  - When Powered by a Charge Adapter, the Main Battery Can Provide Supplemental Current to the System
  - The Charge Adapter Can Support the System Without a Battery
  - 20mΩ BATT to SYS Switch with up to 4.5A Continuous Discharge Capability
- No External MOSFETs Required
- 4.5V to 13.7V Input Operating Voltage
  - Reverse Leakage Protection Prevents the Battery Current Leaking to the Input
  - Automatic Detection of USB Type-C and BC1.2 Adapters
  - 500mA to 3A Automatic Input Current Limit Selection After USB Charger Type Detection
  - Supports Non-USB Sources
- 6-Hour Charge Safety Timer
- Die Temperature Monitor with Thermal Foldback Loop (130°C Threshold)
- Input Voltage Regulation Allows Operation from High-Impedance Sources (AICL)
- Short Circuit Protection
  - BATT to SYS Overcurrent Threshold: 6A
  - SYS Short-to-Ground

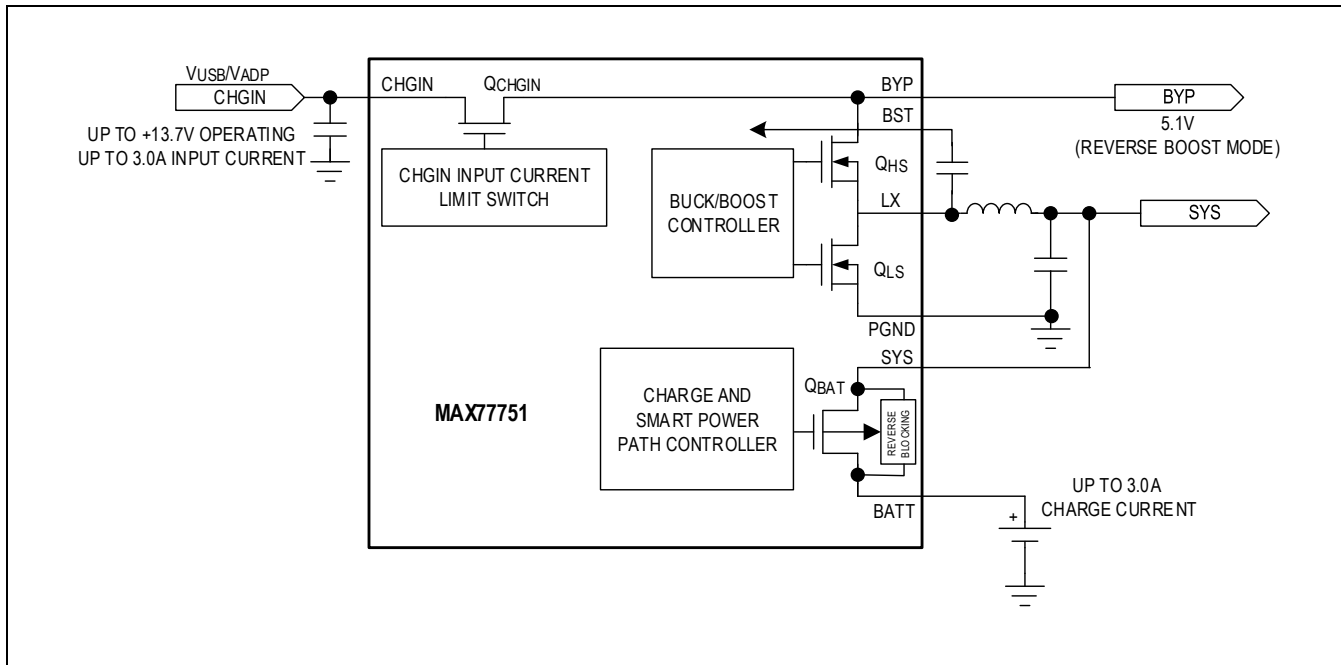

Figure 1. Simplified Functional Diagram

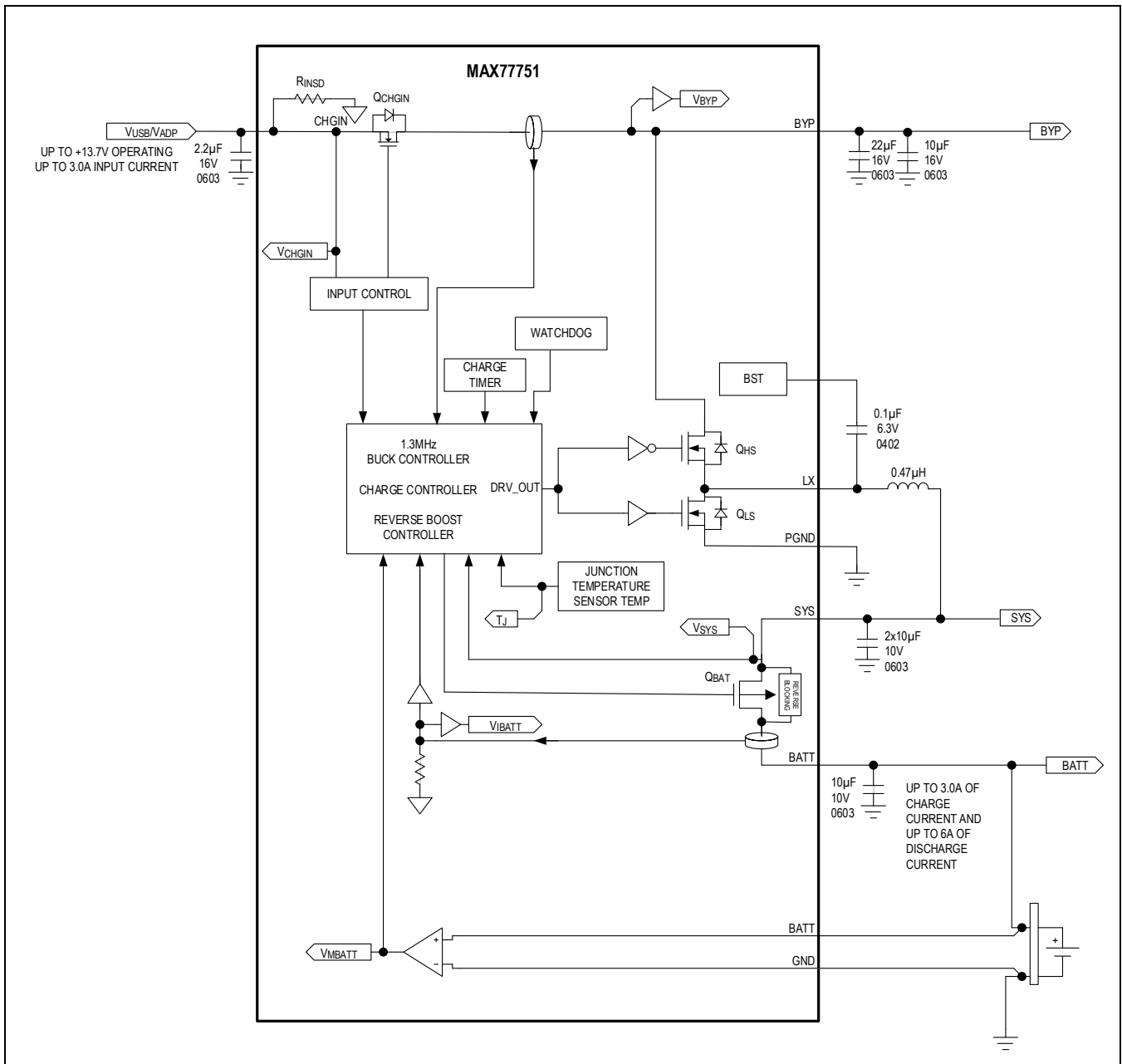

Figure 2. Battery Charger Detailed Functional Diagram

**Detailed Description**

The MAX77751 includes a full-featured switch-mode charger for a one-cell lithium ion (Li+) or lithium polymer (Li-polymer) battery. As shown in [Figure 2](#), the current limit for the CHGIN input is automatically configured allowing the flexibility for connection to either an AC-to-DC wall charger or a USB port.

The synchronous switch-mode DC-DC converter utilizes a high 1.3MHz switching frequency, which is ideal for portable devices because it allows the use of small components while eliminating excessive heat generation. The DC-DC has both a buck and a boost mode of operation. When charging the battery, the converter operates as a buck. The DC-DC buck

operates from a 4.3V to 13.7V source and delivers up to 3.15A to the battery. The battery charge current is programmable from 500mA to 3.15A with an external resistor.

As a boost converter, the DC-DC uses energy from the battery to boost the voltage at BYP. The boosted BYP voltage supplies the power to CHGIN as USB OTG voltage, which is fixed to 5.1V.

Maxim's Smart Power Selector architecture makes the best use of the limited adapter power and the battery power at all times to supply up to the Buck Current Limit from the buck to the system (supplement mode also provides additional current from the battery to the system up to B2SOVRC). Adapter power that is not used for the system goes to charging the battery. All power switches for charging and switching the system load between the battery and adapter power are included on chip—no external MOSFETs are required.

Maxim's proprietary process technology allows for low-RDSON devices in a small solution size. The total dropout resistance from adapter power input to the battery is 165mΩ (typ) assuming that the inductor has 0.04Ω of ESR. This 165mΩ typical dropout resistance allows for charging a battery up to 3.0A from a 5V supply. The resistance from the BATT-to-SYS node is 20mΩ, allowing for low-power dissipation and long battery life.

A multitude of safety features ensures reliable charging. Features include a charge timer, junction thermal regulation, over/undervoltage protection, and short circuit protection.

The BATT-to-SYS switch has overcurrent protection (see the [Battery Overcurrent Protection](#) section for more information).

### Smart Power Selector

The Smart Power Selector (SPS) architecture is a network of internal switches and control loops that distributes energy between CHGIN, BYP, SYS, and BATT.

[Figure 1](#) shows a simplified arrangement for the smart power selector's power steering switches. [Figure 2](#) shows a more detailed arrangement of the smart power selector switches and gives them the following names: Q<sub>CHGIN</sub>, Q<sub>HS</sub>, Q<sub>LS</sub>, and Q<sub>BAT</sub>.

### Switch and Control Loop Descriptions

- CHGIN Input Switch: Q<sub>CHGIN</sub> provides input overvoltage protection of +16V. The input switch is either completely on or completely off. As shown in [Figure 2](#), there are SPS control loops that monitor the current through the input switches as well as the input voltage.
- DC-DC Switches: Q<sub>HS</sub> and Q<sub>LS</sub> are the DC-DC switches which can operate as a buck (step-down) or a boost (step-up). When operating as a buck, energy is moved from BYP to SYS. When operating as a boost, energy is moved from SYS to BYP. SPS control loops monitor the DC-DC switch current, the SYS voltage, and the BYP voltage.
- Battery-to-System Switch: Q<sub>BAT</sub> controls the battery charging and discharging. Additionally, Q<sub>BAT</sub> allows the battery to be isolated from the system (SYS). An SPS control loop monitors the Q<sub>BAT</sub> current.

### SYS Regulation Voltage

- When the DC-DC is enabled as a buck and the charger is enabled but in a non-charging state (i.e., Done, thermal shutdown, or timer fault), V<sub>SYS</sub> is regulated to V<sub>BATTREG</sub> and Q<sub>BAT</sub> is off.
- When the DC-DC is enabled as a buck and is charging in trickle-charge, fast-charge, or top-off modes, V<sub>SYS</sub> is regulated to V<sub>SYSTEMIN</sub> when the V<sub>PRECHG</sub> < V<sub>BATT</sub> < V<sub>SYSTEMIN</sub>. Additionally, when the DC-DC is enabled as a buck and is charging in precharge mode (V<sub>BATT</sub> < V<sub>PRECHG</sub>), V<sub>SYS</sub> is regulated to V<sub>BATTREG</sub>. In these modes, the Q<sub>BAT</sub> switch acts like a linear regulator and dissipates power [P = (V<sub>SYS</sub> - V<sub>BATT</sub>) × I<sub>BATT</sub>]. When V<sub>BATT</sub> > V<sub>SYSTEMIN</sub>, then V<sub>SYS</sub> = V<sub>BATT</sub> + I<sub>BATT</sub> × R<sub>BAT2SYS</sub>. In this mode, the Q<sub>BAT</sub> switch is closed.

For the above modes, if the combined SYS loading exceeds the input current limit, then V<sub>SYS</sub> drops to V<sub>BATT</sub> - V<sub>BSREG</sub>, and the battery provides supplemental current.

**Input Validation**

The charger input is compared with several voltage thresholds to determine if it is valid. A charger input must meet the following three characteristics to be valid:

- CHGIN must be above  $V_{CHGIN\_UVLO}$  to be valid  
Once CHGIN is above the UVLO threshold, the information (together with LIN2SYS, as shown in [Figure 3](#)) is latched and can only be reset when the charger is in the adaptive input current loop (AICL) and the input current is lower than the IULO threshold of 60mA. Note that  $V_{CHGIN\_REG}$  is lower than the UVLO falling threshold.
- CHGIN must be below its overvoltage lockout threshold ( $V_{CHGIN\_OVLO}$ )
- CHGIN must be above the system voltage ( $V_{CHGIN2SYS}$ )

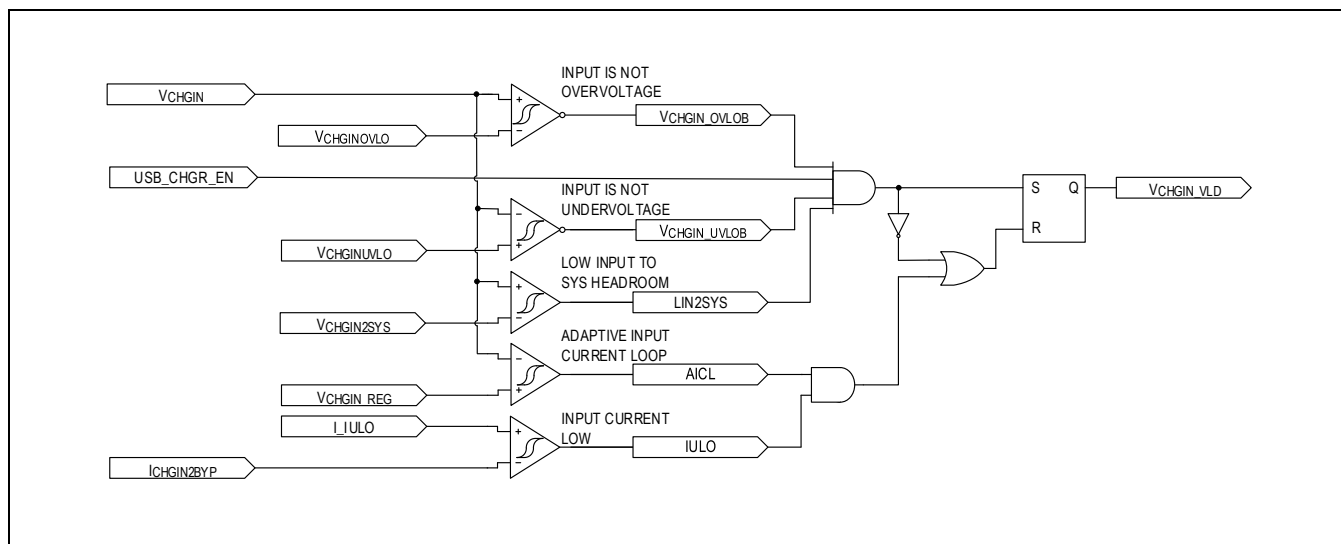

Figure 3. CHGIN Valid Signal Generation Logic

If  $V_{CHGIN}$  is greater than  $V_{CHGIN\_UVLO}$ , the USB Type-C CC and BC1.2 detection process starts. After the MAX77751 finishes USB detection, the switcher in the chip starts. The system can detect that a valid charger is present by the INOKB output signal, which is issued when the switcher starts and the  $V_{CHGIN\_VLD}$  signal is valid, as shown in [Figure 4](#).

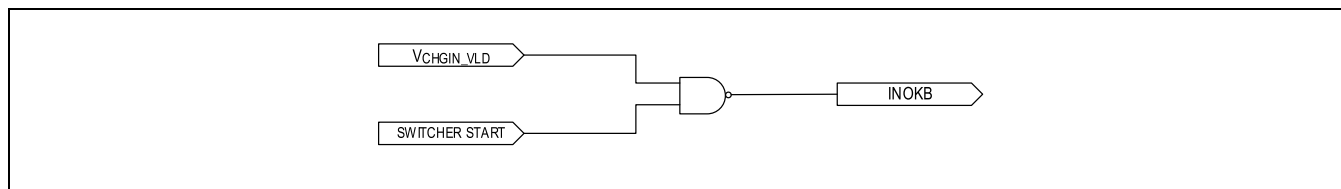

Figure 4. INOKB Signal Generation Logic

**Input Current Limit**

After the charger-type detection is done, the MAX77751 automatically configures the input current limit to the highest settings that the source can provide. If the input source is not a standard power source described by BC1.2 or USB Type-C or is not a proprietary charger type that the MAX77751 can detect, the MAX77751 sets the input current limit to 3A.

**Input Voltage Regulation Loop**

An input voltage regulation loop allows the charger to be well behaved when it is attached to a poor-quality charge source. The loop improves performance with relatively high resistance charge sources that exist when long cables are used or devices are charged with noncompliant USB hub configurations.

The input voltage regulation loop automatically reduces the input current limit in order to keep the input voltage at  $V_{CHGIN\_REG}$ . If the input current limit is reduced to  $I_{CHGIN\_REG\_OFF}$  (50mA typ) and the input voltage is below  $V_{CHGIN\_REG}$ , then the charger input is turned off.

**Input Self-Discharge**

When the charge source is removed, the input voltage decays below the UVLO threshold in time ( $t_{INSD}$ ). The input self-discharge is implemented with a 44kΩ resistor ( $R_{INSD}$ ) from the CHGIN input to ground.

**Charger States**

The MAX77751 utilizes several charging states to safely and quickly charge batteries, as shown in [Figure 5](#) and [Figure 6](#). [Figure 5](#) shows an exaggerated view of a Li+/Li-Poly battery progressing through the following charge states when there is no system load and the die and battery are close to room temperature: precharge → trickle → fast-charge → top-off → done.

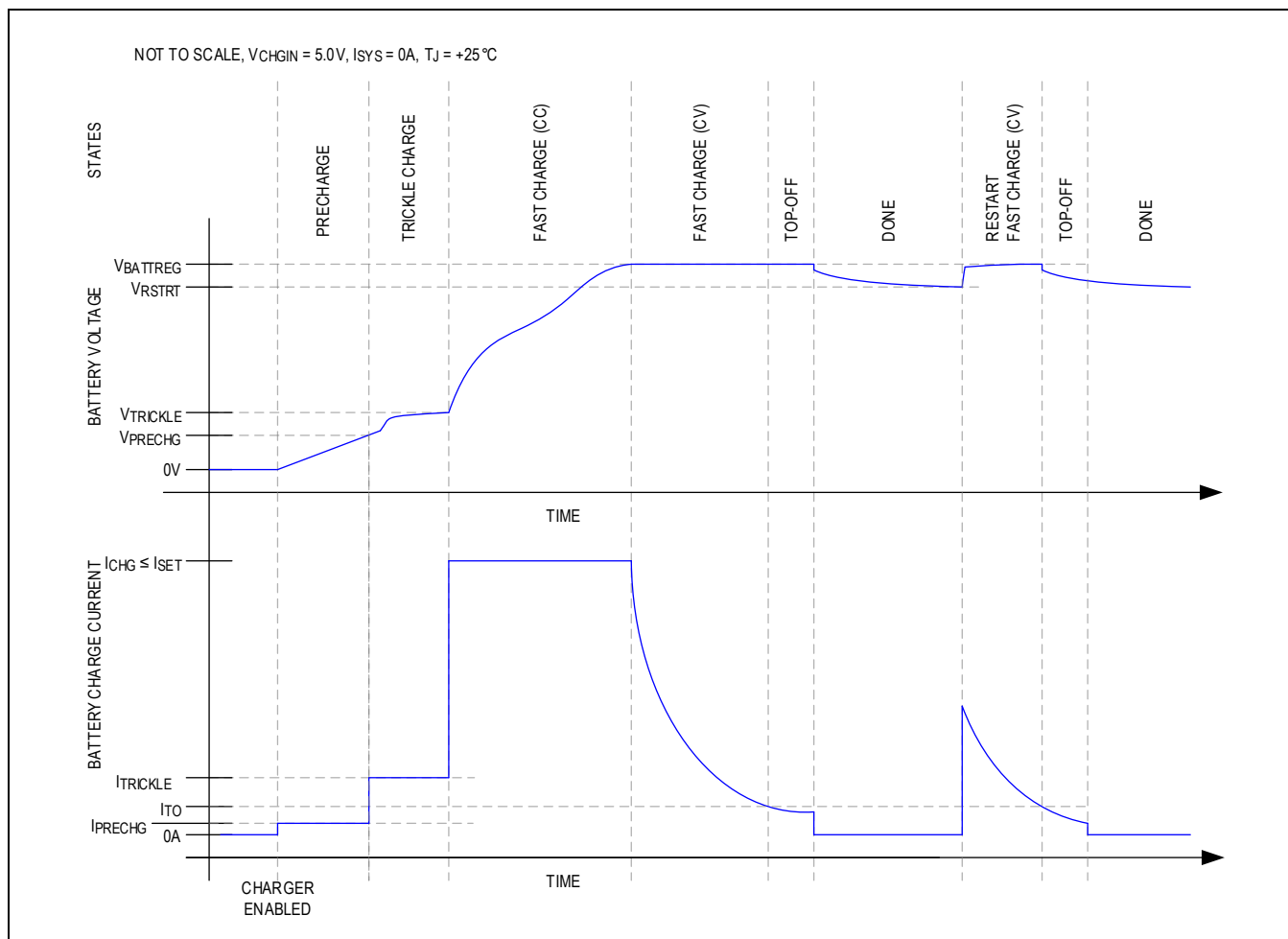

Figure 5. Li+/Li-Poly Charge Profile

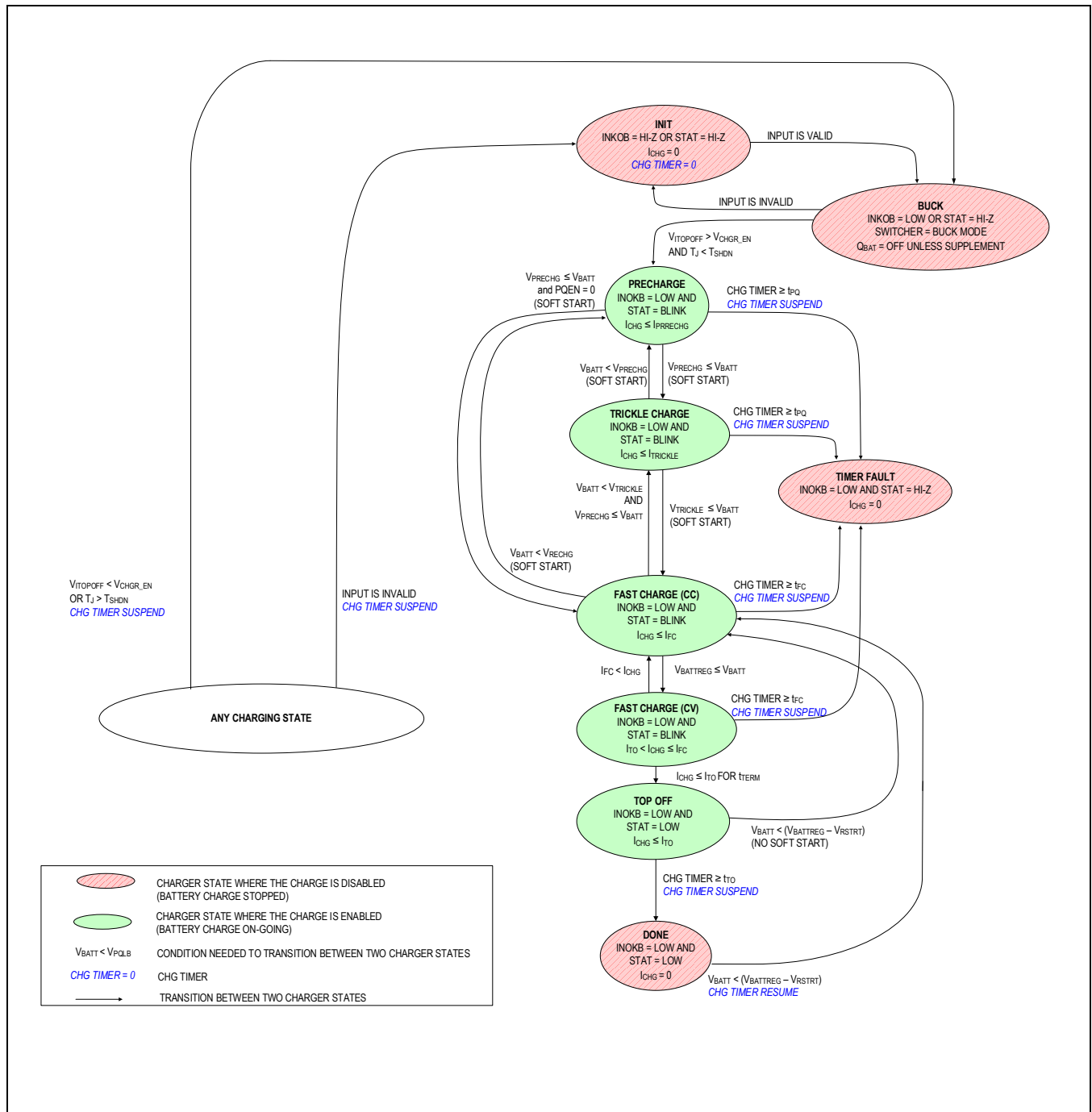

Figure 6. Charger State Diagram

**INIT State**

From any state shown in [Figure 6](#) except thermal shutdown, the INIT state is entered whenever the charger inputs that CHGIN is invalid or the charger timer is suspended.

While in the INIT state, the charger current is 0mA, the charge timer is forced to 0, and the power to the system is provided by the battery.

To exit the INIT state, the charger input must be valid.

**Buck State**

The chip has a state where battery charging is disabled while the charger input CHGIN is valid. The state is called buck state. Entering or leaving buck state is controlled by the voltage of the ITOPOFF pin. If the voltage of this pin is pulled down by an external device (i.e., MCU) under  $V_{CHGR\_EN}$ , the chip goes to the buck state from any state if CHGIN is valid, as shown in [Figure 6](#). In the buck state, charging is disabled, which means  $Q_{BAT}$  is off, unless it is in supplement mode. If the voltage of this pin is over  $V_{CHGR\_EN}$ , the chip gets out of the buck state and resumes charging. Note that only when CHGIN is valid, charging can be enabled or disabled. Therefore, the external device (i.e., MCU) should check using the INOKB signal if CHGIN is valid before trying to enable or disable charging.

**Precharge State**

As shown in [Figure 6](#), the precharge state occurs when the battery voltage is less than  $V_{PRECHG}$ . In the precharge state, charge current into the battery is  $I_{PRECHG}$ .

The following events cause the state machine to exit this state:

- Battery voltage rises above  $V_{PRECHG}$ , and the charger enters the next state in the charging cycle, trickle charge state.
- If the battery charger remains in this state for longer than  $t_{PQ}$ , the charger state machine transitions to the timer fault state.

The precharge state works with battery voltages down to 0V. The low 0V operation typically allows this battery charger to recover batteries that have an “open” internal pack protector. Typically, an internal pack protection circuit opens if the battery has seen an overcurrent, undervoltage, or overvoltage. When a battery with an “open” internal pack protector is used with this charger, the precharge state current flows into the 0V battery—this current raises the pack’s terminal voltage to the voltage level where the internal pack protection switch closes.

Note that a normal battery typically stays in the precharge state for several minutes or less. Therefore, a battery that stays in the precharge state for longer than  $t_{PQ}$  might be experiencing a problem.

**Trickle Charge State**

As shown in [Figure 6](#), the trickle charge state occurs when  $V_{BATT} > V_{PRECHG}$  and  $V_{BATT} < V_{TRICKLE}$ .

When the MAX77751 is in the trickle charge state, the charge current in the battery is less than or equal to  $I_{TRICKLE}$ .

The charge current might be less than  $I_{TRICKLE}$  for any of the following reasons:

- The charger input current is lower than the input current limit
- The charger input voltage is low
- The charger is in thermal foldback
- The system load is consuming adapter current. Note that the system load always gets priority over the battery charge current.

The following events cause the state machine to exit this state:

- When the main battery voltage rises above  $V_{TRICKLE}$ , the charger enters the next state in the charging cycle, fast-charge constant current state.
- If the battery charger remains in this state for longer than  $t_{PQ}$ , the charger state machine transitions to the timer fault state.

Note that a normal battery typically stays in the trickle charge state for several minutes or less. Therefore, a battery that stays in trickle charge state for longer than  $t_{PQ}$  might be experiencing a problem.



**Fast-Charge Constant Current State**

As shown in [Figure 6](#), the fast-charge constant current (CC) state occurs when the battery voltage is greater than the trickle threshold and less than the battery regulation threshold ( $V_{TRICKLE} < V_{BATT} < V_{BATTREG}$ ).

In the fast-charge CC state, the current into the battery is less than or equal to  $I_{FC}$ . The charge current can be less than  $I_{FC}$  for any of the following reasons:

- The charger input current is lower than the input current limit
- The charger input voltage is low
- The charger is in thermal foldback
- The system load is consuming adapter current. Note that the system load always gets priority over the battery charge current.

The following events cause the state machine to exit this state:

- When the battery voltage rises above  $V_{BATTREG}$ , the charger enters the next state in the charging cycle, fast-charge constant voltage state.
- If the battery charger remains in this state for longer than  $t_{FC}$ , the charger state machine transitions to the timer fault state.

The battery charger dissipates the most power in the fast-charge CC state. This power dissipation causes the internal die temperature to rise. If the die temperature exceeds  $T_{REG}$ ,  $I_{FC}$  is reduced. See the [Thermal Foldback](#) section for more information.

**Fast-Charge Constant Voltage State**

As shown in [Figure 6](#), the fast-charge constant voltage (CV) state occurs when the battery voltage rises to  $V_{BATTREG}$  from the fast-charge CC state.

In the fast-charge CV state, the battery charger maintains  $V_{BATTREG}$  across the battery, and the charge current is less than or equal to  $I_{FC}$ . As shown in [Figure 5](#), the charger current decreases exponentially in this state as the battery becomes fully charged.

The smart power selector control circuitry might reduce the charge current lower than the battery can otherwise consume for any of the following reasons:

- The charger input current is lower than the input current limit
- The charger input voltage is low
- The charger is in thermal foldback
- The system load is consuming adapter current. Note that the system load always gets priority over the battery charge current.

The following events cause the state machine to exit this state:

- When the charger current is below  $I_{TO}$  for  $t_{TERM}$ , the charger enters the next state in the charging cycle, top-off state.
- If the battery charger remains in this state for longer than  $t_{FC}$ , the charger state machine transitions to the timer fault state.

### Top-Off State

As shown in [Figure 6](#), the top-off state can only be entered from the fast-charge CV state when the charger current decreases below  $I_{TO}$  for  $t_{TERM}$ . In the top-off state, the battery charger tries to maintain  $V_{BATTREG}$  across the battery, and typically, the charge current is less than or equal to  $I_{TO}$ .

The smart power selector control circuitry might reduce the charge current lower than the battery can otherwise consume for any of the following reasons:

- The charger input current is lower than the input current limit
- The charger input voltage is low
- The charger is in thermal foldback
- The system load is consuming adapter current. Note that the system load always gets priority over the battery charge current.

The following events cause the state machine to exit this state:

- After being in this state for the top-off time ( $t_{TO}$ ), the charger enters the next state in the charging cycle, done state.
- If  $V_{BATT} < V_{BATTREG} - V_{RSTRT}$ , the charger goes back to the fast-charge CC state

### Done State

As shown in [Figure 6](#), the battery charger enters its done state after the charger has been in the top-off state for  $t_{TO}$ .

The state machine exits this state if  $V_{BATT} < V_{BATTREG} - V_{RSTRT}$  and the charger goes back to the fast-charge CC state

In the done state, the charge current into the battery ( $I_{CHG}$ ) is 0A, and the charger presents a very low quiescent current to the battery. If the system load presented to the battery is low ( $\ll 100\mu A$ ), then a typical system can remain in the done state for many days. If left in the done state long enough, the battery voltage decays below the restart threshold ( $V_{RSTRT}$ ) and the charger state machine transitions back into the fast-charge CC state. There is no soft-start (di/dt limiting) during the done state to fast-charge state transition.

### Timer Fault State

The battery charger provides a charge timer to ensure safe charging. As shown in [Figure 6](#), the charge timer prevents the battery from charging indefinitely. The time that the charger is allowed to remain in each of its prequalification states is  $t_{PQ}$ . The time that the charger is allowed to remain in the fast-charge CC and fast-charge CV states is  $t_{FC}$ . Finally, the time that the charger is in the top-off state is  $t_{TO}$ . Upon entering the timer fault state, STAT becomes Hi-Z.

In the timer fault state, the charger is off. The charger input can be removed and re-inserted to exit the timer fault state (see the “any state” bubble in the lower left of [Figure 6](#)).

### Thermal Shutdown State

As shown in [Figure 6](#), the thermal shutdown state occurs when the battery charger is in any state and the junction temperature ( $T_J$ ) exceeds the device’s thermal shutdown threshold (TSHDN). When  $T_J$  is close to  $T_{REG}$ , the charger folds back the charge current to 0A so that the charger is effectively off (see the [Thermal Foldback](#) section).

In the thermal shutdown state, the charger is off.

**Reverse Boost Mode**

The DC-DC converter topology of the MAX77751 allows it to operate as a buck converter or as a reverse boost converter. The modes of the DC-DC converter are controlled by ENBST. When ENBST = high, the DC-DC converter operates in reverse boost mode allowing it to source current to BYP and CHGIN. It is commonly referred to as OTG mode or a source role.

The current through the BYP to CHGIN switch is limited to 1.5A minimum. When the reverse boost mode is enabled, the unipolar CHGIN transfer function measures current going out of CHGIN.

The BYP to CHGIN switch automatically tries to retry after 300ms if CHGIN loading exceeds the 1.5A current limit. If the overload at CHGIN persists, then the CHGIN switch toggles ON and OFF with approximately 60ms ON and approximately 300ms OFF.

**Battery Overcurrent Protection During System Power-Up**

The battery overcurrent protection during system power-up feature limits the battery to system current to  $I_{SYSPU}$  if  $V_{SYS}$  is less than  $V_{SYSPU}$ . This feature limits the surge current that typically flows from the battery to the device's low-impedance system to bypass capacitors during a system power-up. System power-up is anytime that energy from the battery is supplied to SYS when  $V_{SYS} < V_{SYSPU}$ . This system power-up condition typically occurs when a battery is hot inserted into an otherwise unpowered device.

When system power-up occurs due to hot-insertion into an otherwise unpowered device, a small delay is required for this feature's control circuits to activate. A current spike over  $I_{SYSPU}$  might occur during this time.

**Battery Overcurrent Protection Due to Fault**

The MAX77751 protects itself, the battery, and the system from potential damage due to excessive battery discharge current. Excessive battery discharge current can occur for several reasons such as exposure to moisture, a software problem, an IC failure, a component failure, or a mechanical failure that causes a short circuit.

When the battery (BATT)-to-system (SYS) discharge current ( $I_{BATT}$ ) exceeds 6A for at least  $t_{BOVRC}$ , then the MAX77751 disables the BATT-to-SYS discharge path ( $Q_{BAT}$  switch) and turns off buck.

Under the OCP fault condition, when SYS is low ( $V_{SYS} < V_{SYSUP}$ ) for  $t_{OCP\_RETRY}$ , the MAX77751 restarts on its own and attempts to pull up SYS again. If the fault condition remains, the whole cycle repeats until this fault condition is removed.

**Thermal Foldback**

Thermal foldback maximizes the battery charge current while regulating the MAX77751 junction temperature. As shown in [Figure 7](#), when the die temperature exceeds the REGTEMP ( $T_{REG}$ ), a thermal limiting circuit reduces the battery charger's target current by 5% of the fast charge current per 1°C ( $A_{TJREG}$ ), which corresponds to 157.5mA/°C when the fast charge current is 3.15A. The target charge current reduction is achieved with an analog control loop (i.e., not a digital reduction in the input current).

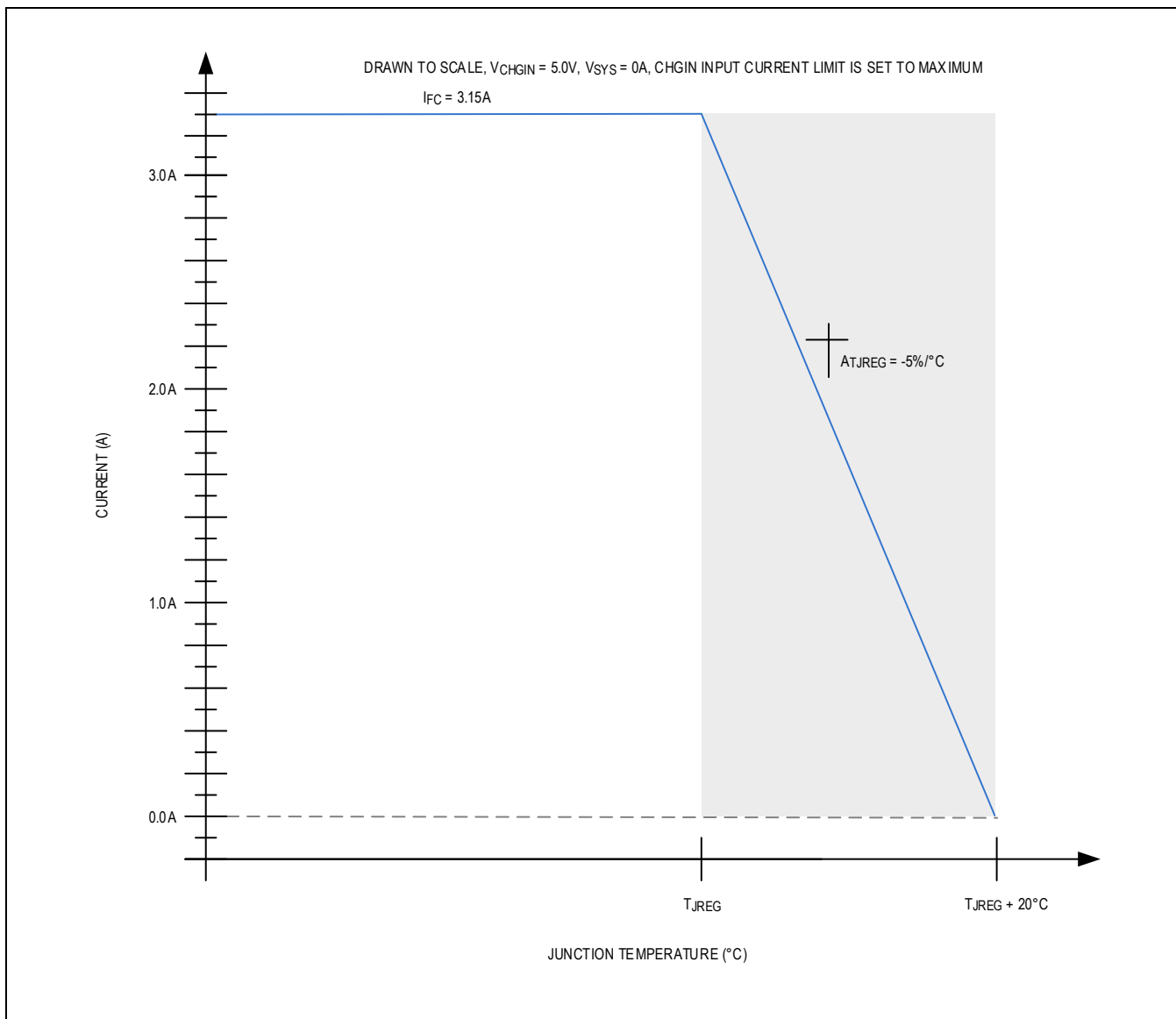

Figure 7. Charge Currents vs. Junction Temperature

**V<sub>DD</sub> Internal Supply**

V<sub>DD</sub> is the 1.8V power for the MAX77751 charger's analog circuit. V<sub>DD</sub> is generated from the higher value between BATT and CHGIN as the power input source and generates the internal power supply. V<sub>DD</sub> has a bypass capacitance of 2.2μF.

**ENBST For Reverse Boost**

ENBST is an input control signal for the reverse boost mode with an external logic signal. If ENBST is driven high, the reverse boost is enabled and the BYP-to-CHGIN path is closed. ENBST has an internal 235kΩ pulldown resistor. When ENBST sets to high, the MAX77751 disconnects R<sub>d</sub> from the CC line and provides a 180μA current source.

**USB BC1.2 Charger Detection****Features**

- D+/D- Charging Signature Detector
- USB BC1.2 Compliant SDP, DCP, and CDP Detection
- Proprietary Charger Types Detection
  - Apple 500mA, 1A, 2A, 2.4A
  - Samsung 2A

**Description**

The USB charger detection is USB BC1.2 compliant with the ability to automatically detect some common proprietary charger types.

The Charger Detection State Machine follows USB BC1.2 requirements and detects SDP, CDP, and DCP types. In addition to the USB BC1.2 State Machine, the IC also detects a limited number of proprietary charger types (Apple and Samsung). The IC automatically sets the CHGIN input current limit based on the charger type detection results. If charger type detection results are an unknown charger type or D+/D- are found as open, the input current limits are set to 3A max.

**Table 1. USB BC1.2 Detected Charger Type**

INPUT CURRENT LIMIT	CHARGER DETECTED
500mA	SDP
1.5A	CDP
1.5A	DCP

**Table 2. Detected Proprietary Charger Type**

INPUT CURRENT LIMIT	CHARGER DETECTED
500mA	Apple
1A	Apple
2A	Apple
2.4A	Apple
2A	Samsung
3A	All others

## USB Type-C CC Detection

### Features

- USB Type-C Sink Support
- CC Source Detection
  - Automatic Set of the Input Current Limit According to Source Capability
- Source Role Support by ENBST Pin

### CC Description

The MAX77751 is sink compliant to the USB Type-C Rev 1.2 specifications. The USB Type-C functions are controlled by a logic state machine which follows the USB Type-C requirements. The MAX77751 sets the CHGIN input current limit based on the current advertised on the CC wires. The source role is enabled by the ENBST pin. When the source role is enabled, Rd is removed, and a 180 $\mu$ A current source is connected.

### Detecting Connected Source

When a source is detected, the USB Type-C state machine auto detects the active CC line. The state machine also automatically detects the source advertised current (500mA, 1.5A, and 3.0A). Upon detection of a change in the advertised current, the MAX77751 automatically sets the input current limit.

### D+/D- Detection in CC Detection

The MAX77751 executes D+/D- detection and CC detection in parallel and takes the higher of the two input current limit values determined by D+/D- detection and by CC detection. No connection in the D+ and D- lines is considered as an unknown adapter, and therefore the final input current limit is always 3A, regardless of the CC detection result.

### Non-USB Type-C Connector Cases

Some target systems could have other types of connectors such as Micro-B and barrel connectors other than USB Type-C connectors. Since the Micro-B connector does not have CC1 and CC2 pins and the barrel connector does not have CC1, CC2, D+ and D- pins, the recommended connections described in the following sections can be used in the target system.

#### Micro-B Connector

In the case of a Micro-B connector, CC1 and CC2 can be floated as shown in [Figure 8](#). When CC1 and CC2 are floating, the MAX77751 determines the input current limit solely based on D+/D- detection such as BC1.2 and some proprietary TA detection.

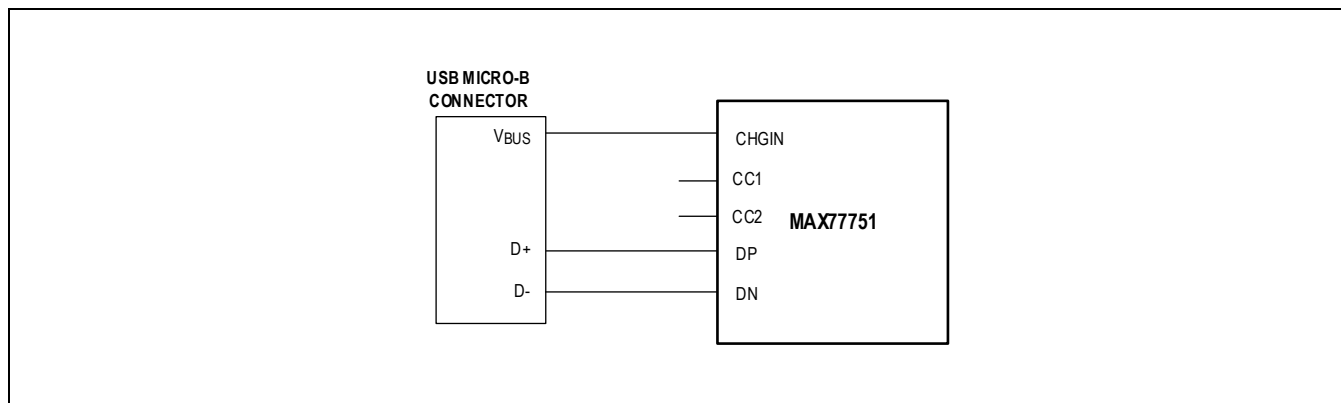

Figure 8. USB Signal Connections for a Micro-B Connector

### Barrel Connectors

When a barrel connector is used in the application, there is no connection to determine the input current limit. Resistors can be connected to mimic BC1.2 detection and/or CC detection to configure the desired input current limit. If the capacity of the power source is 500mA, the MAX77751 can set the input current limit to 500mA by configuring resistors on DP/DN for BC1.2 SDP ([Figure 9](#)). R1 and R2 should have the same resistance with the recommended value of 20k $\Omega$ . Meanwhile, if the capacity of the power source is 1.5A, the MAX77751 can set the input current limit to 1.5A by connecting a resistor for BC1.2 DCP as shown in [Figure 10](#). The recommended value of resistor R is 200 $\Omega$ .

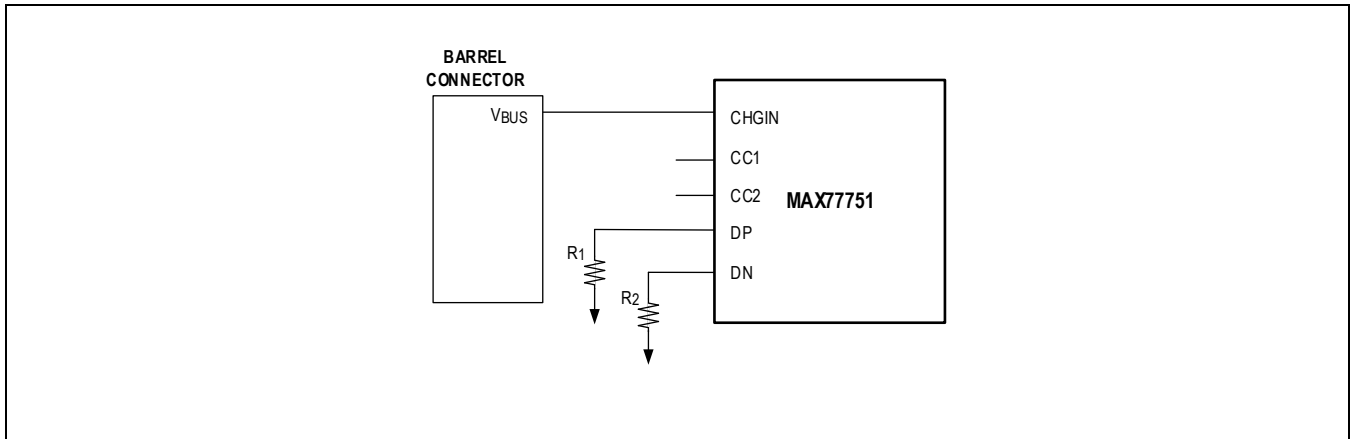

Figure 9. Connections for a Barrel Connector (500mA Power Source)

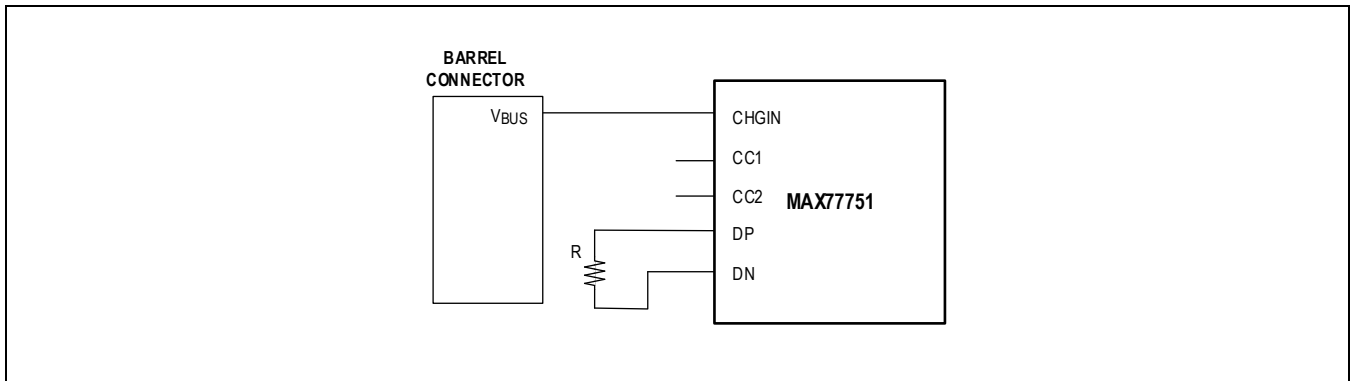

Figure 10. Connections for a Barrel Connector (1.5A Power Source)

### Enable Source Role

ENBST = high enables the MAX77751's source role. The MAX77751 disconnects  $R_d$  from the CC line and connects an 180 $\mu$ A current source to advertise the 5V/1.5A power source. The MAX77751 enables the reverse boost and supply 5.1V/1.5A through the CHGIN pin.

## Applications Information

### Fast-Charge Current Setting

When a valid input source is present, the battery charger attempts to charge the battery with a fast-charge current determined by the resistance from I<sub>FAST</sub> to GND. [Table 3](#) shows the resistance values which correspond to the target I<sub>FAST</sub> values.

**Table 3. Fast-Charge Current Settings**

RESISTANCE (kΩ)	I <sub>FAST</sub> (mA)
24.9	3150
22.6	3000
20.5	2800
18.7	2500
16.9	2400
15.4	2200
14	2000
12.4	1800
11	1500
9.53	1400
8.2	1200
6.65	1000
5.23	800
3.6	600
2.4	500

### Top-Off Current Setting

The top-off charging current is programmed by an external resistor connected from I<sub>TOPOFF</sub> to GND (R<sub>TOPOFF</sub>). [Table 4](#) shows the resistance values which correspond to the target I<sub>TOPOFF</sub> values.

**Table 4. Top-Off Current Settings**

R <sub>TOPOFF</sub> (kΩ)	I <sub>TOPOFF</sub> (mA)
24.3	350
19.6	300
16.5	250
13.3	200
10.2	150
8.06	100

### D+/D- Multiplexing

The USB D+/D- lines, which are used for BC1.2 and proprietary adapter detection, can be used for data communication. If an MCU handles this communication in the target system, the D+/D- lines can be connected to the MAX77751 and the MCU, as shown in [Figure 11](#). The switchers are required for each D+ and D- lines to guarantee high impedance state for the MCU connections to avoid incorrect adapter detection. It is recommended to connect the MAX77751's INOKB to the MCU in this configuration so that the MAX77751 can signal that detection is complete to the MCU. When the MCU receives a valid INOKB signal, it can switch the D+/D- lines from the MAX77751 to the MCU for data communication.



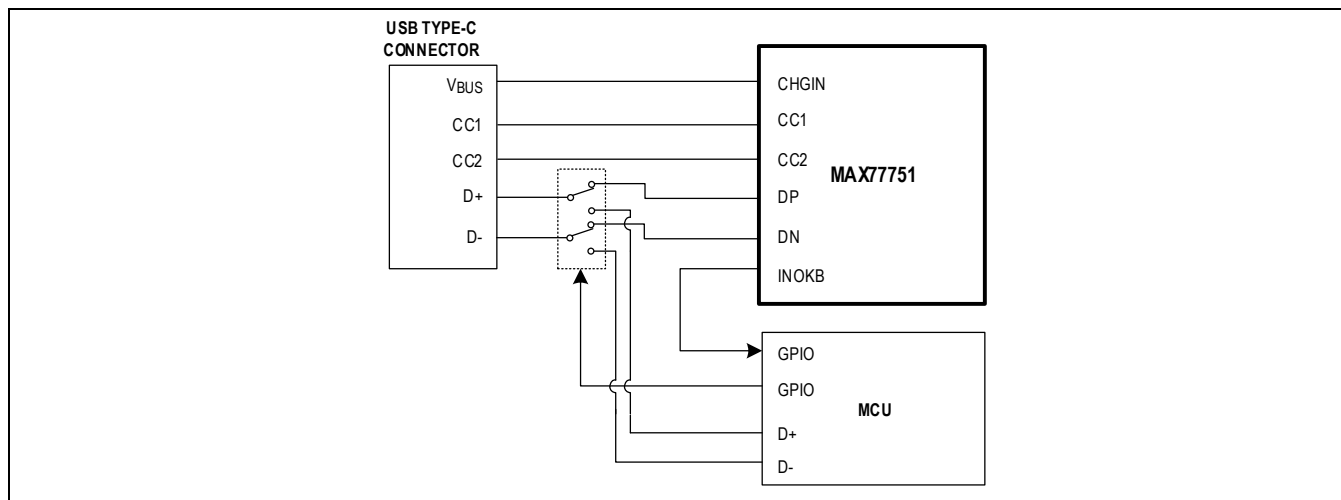

Figure 11. D+/D- Connections in a Reference System

### Capacitor Selection

All capacitors should be X5R dielectric or better. Be aware that multi-layer ceramic capacitors have large voltage coefficients. Before selecting capacitors, check for sufficient voltage rating and derated capacitance at the max operating voltage condition. [Table 5](#) shows the capacitors to select after considering the derating and operating voltage.

**Table 5. Capacitor Selections**

PIN	TYPE
CHGIN Capacitor	2.2µF/16V
BYP Capacitor	10µF + 22µF/16V
SYS Capacitor	2x10µF/10V
BATT Capacitor	10µF/10V
VDD Capacitor	2.2µF/10V
PVL Capacitor	2.2µF/10V
BST Capacitor	100nF/6.3V

### Thermal Considerations

If the system that includes the MAX77751 can read the battery temperature, the temperature can be controlled by adjusting the battery current through enabling switching and disabling charging. As described in the [Buck State](#) section, charging is disabled by pulling the ITOPOFF pin low. [Figure 12](#) shows a recommended system diagram where the MCU has an ADC to sense the temperature, a GPIO output connected to ITOPOFF to enable or disable charging, and a GPIO input connected to INOKB to check the presence of a valid charger. Note that the GPIO output should be an open-drain type. In this system configuration, if the MCU judges the temperature is too high, the MCU should pull the GPIO output low to disable charging. It is important to check if a valid charger is present through the INOKB signal before disabling charging. Pulling ITOPOFF low when the INOKB signal is high (i.e., inactive) could affect the TOPOFF current sensing. Meanwhile, if the temperature goes back to normal, the MCU should make the GPIO be high impedance state to enable charging.

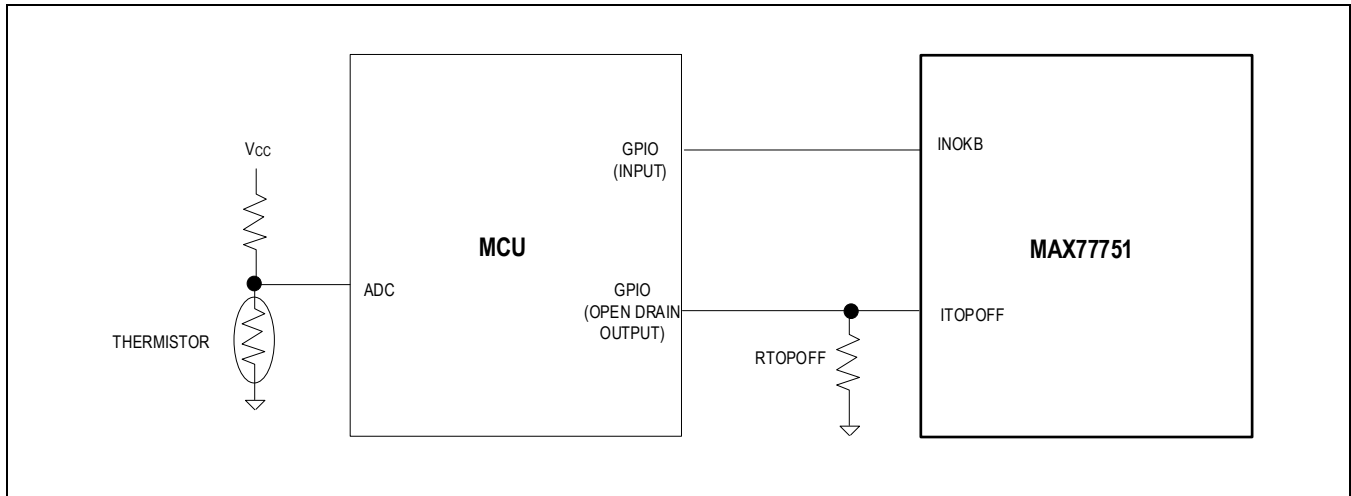

Figure 12. System Configuration for Temperature Management

If the system does not have an MCU which can get the INOKB signal from the MAX77751 and provide the enable or disable signal to ITOPOFF of the MAX77751, the circuit depicted in [Figure 13](#) can provide the same function which the MCU does in [Figure 12](#). The Hot and Cold Temperature Detection portion of the circuit detects if the temperature is greater than the hot threshold or less than the cold threshold. If the temperature is hot or cold, it provides the disable signal (Active High) to the INOKB Control portion of the circuit, which can control the disable signal according to the INOKB status. If INOKB is high (i.e., the charger input is not valid), the disable signal from the temperature detection part is blocked. If INOKB is low (i.e., the charger input is valid), the disable signal passes through the INOKB Control part and reach the ITOPOFF pin of the MAX77751. If the output of the temperature detection part is high (i.e., the disable signal) when INOKB is low, ITOPOFF is pulled low, and battery charging through the MAX77751 is disabled.

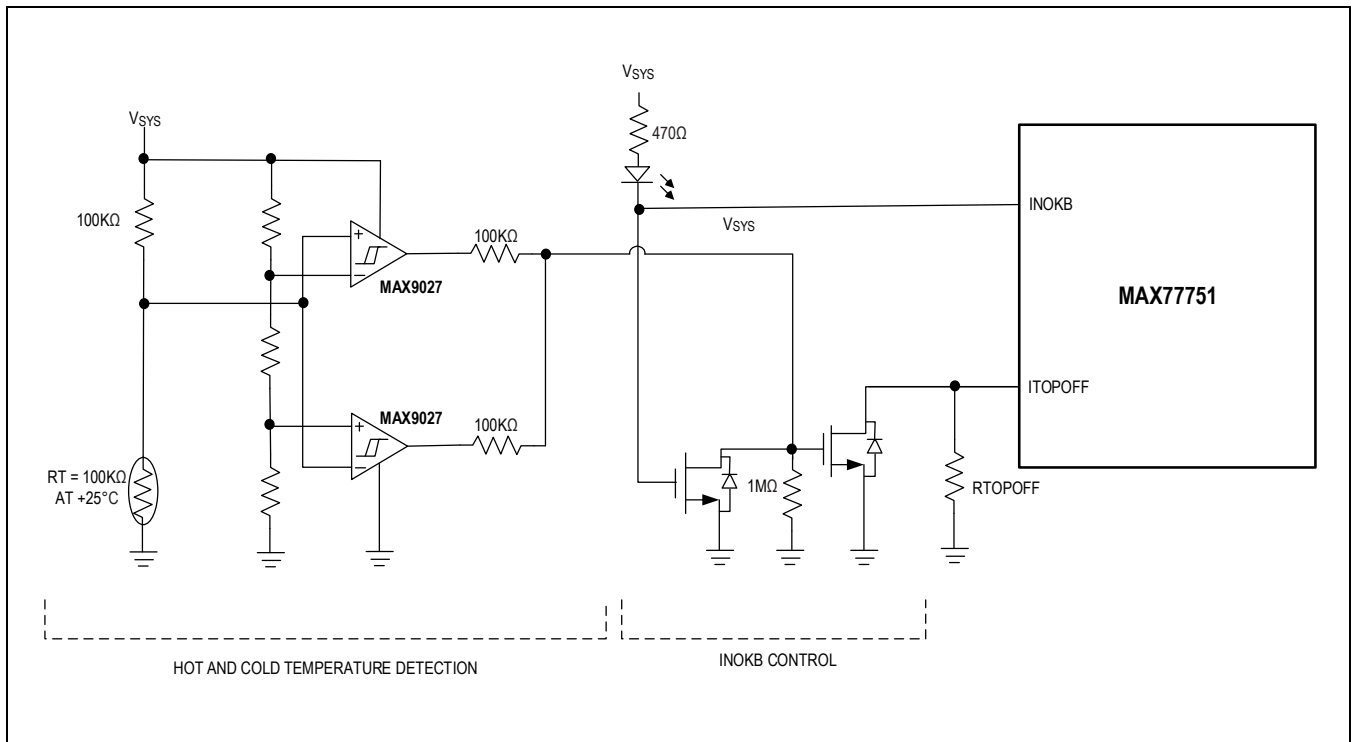

Figure 13. System Configuration for Temperature Management

### Non-USB Type Power Source

In an application where the power source is not USB, all the USB related pins such as CC1, CC2, DP, and DN should be left not connected (NC). In this case, the input current to the MAX77751 is limited to 3A.

### Recommended PCB Layout and Routing

Place all bypass capacitors for CHGIN, BYP, SYS,  $V_{DD}$ , and BATT as close as possible to the IC. Connect the battery to BATT as close as possible to the IC to provide accurate battery voltage sensing. Provide a large copper ground plane to allow the PGND pad to sink heat away from the device. Use wide and short traces for high current connections such as CHGIN, BYP, SYS, and BATT to minimize voltage drops. The MAX77751 has two kinds of ground pins: PGND and GND. Carefully connect PGND because it is a switching node ground of the Charger Buck. It should be tied to ground of the SYS and BYP capacitors and connected to the ground plane directly without sharing other ground. The GND can be connected to the ground plane.

[Figure 14](#) is a recommended placement and layout guide.

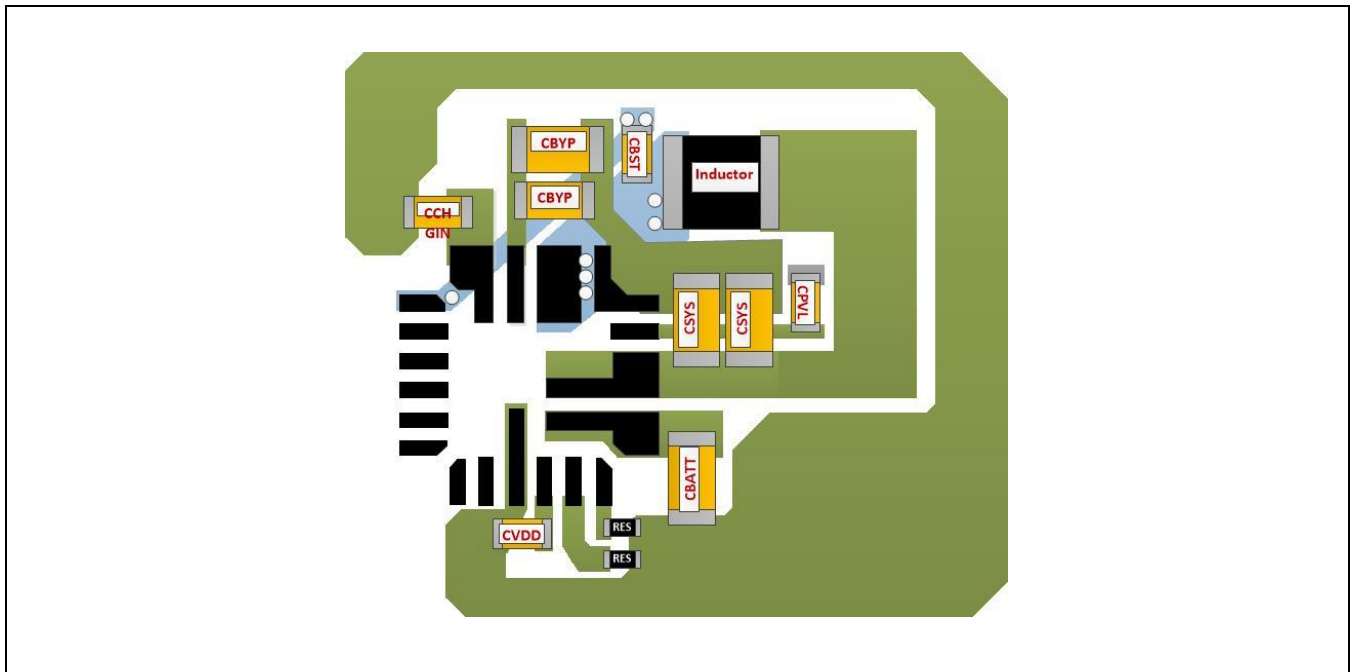

Figure 14. Recommended Placement and Layout

### Inductor Selection

The MAX77751's control scheme requires an external inductor from 0.47 $\mu$ H to 1 $\mu$ H for proper operation.

**Table 6. Recommended Inductors**

MANUFACTURER	PART NUMBER	INDUCTANCE ( $\mu$ H)	I <sub>SAT(TYP)</sub> (A)	I <sub>RMS(TYP)</sub> (A)	DCR(TYP) (m $\Omega$ )	SIZE (L x W x T) (mm)
SEMCO	CIGT252008LMR47MNE	0.47	5.5	4.5	24	2.5 x 2.0 x 0.8
SEMCO	CIGT252010LMR47MNE	0.47	6	4.5	24	2.5 x 2.0 x 1.0
SEMCO	CIGT201610EHR47MNE	0.47	5.9	5	18	2.0 x 1.6 x 1.0
CYNTEC	HTGH25201T-R47MSR-68	0.47	6.6	5.6	16.5	2.5 x 2.0 x 1.0

### Charger Status Outputs

#### Input Status (INOKB)

INOKB is an open-drain and active low output that indicates the input status. If a valid input source is inserted and the buck converter starts switching, INOKB pulls low. When the reverse boost is enabled, INOKB pulls low to indicate 5V output from CHGIN.

INOKB can be used as a logic output for the system processor by adding a 200k $\Omega$  pullup resistor to the system IO voltage.

INOKB can also be used as an LED indicator driver by adding a current limit resistor and an LED to SYS.

#### Charging Status Output (STAT)

STAT is an open-drain and active low output that indicates charge status. [Table 7](#) shows the STAT status changes.

**Table 7. STAT Output Per Charging Status**

CHARGING STATUS	STAT	LOGIC STATE	CHARGE STATUS LED
No input	High impedance	High	Off
Trickle, precharge, fast charge	Repeat low and high impedance with 1Hz, 50% duty cycle	After an external diode and a capacitor rectifier, high	Blinking with 1Hz, 50% duty cycle.
Top-off and done	Low	Low	Solid on
Faults	High impedance	High	Off

STAT can be used as a logic output for the system processor by adding a 200k $\Omega$  pullup resistor to the system IO voltage and a rectifier (a diode and a capacitor).

STAT also can be used as an LED indicator driver by adding a current limit resistor and an LED to SYS.

Typical Application Circuit

Figure 15 illustrates a typical charger application using the MAX77751. Although there are connections between the MCU and the MAX77751, USB detection and battery charging occur automatically without MCU intervention. In the application, the MCU performs two functions: controls the D+/D- switch (MAX4906) and enables or disables battery charging. For the latter function, the MCU can be replaced by the circuit shown in Figure 13. ENBST can also be implemented in different ways and is typically expected to be a switch or button of the target device.

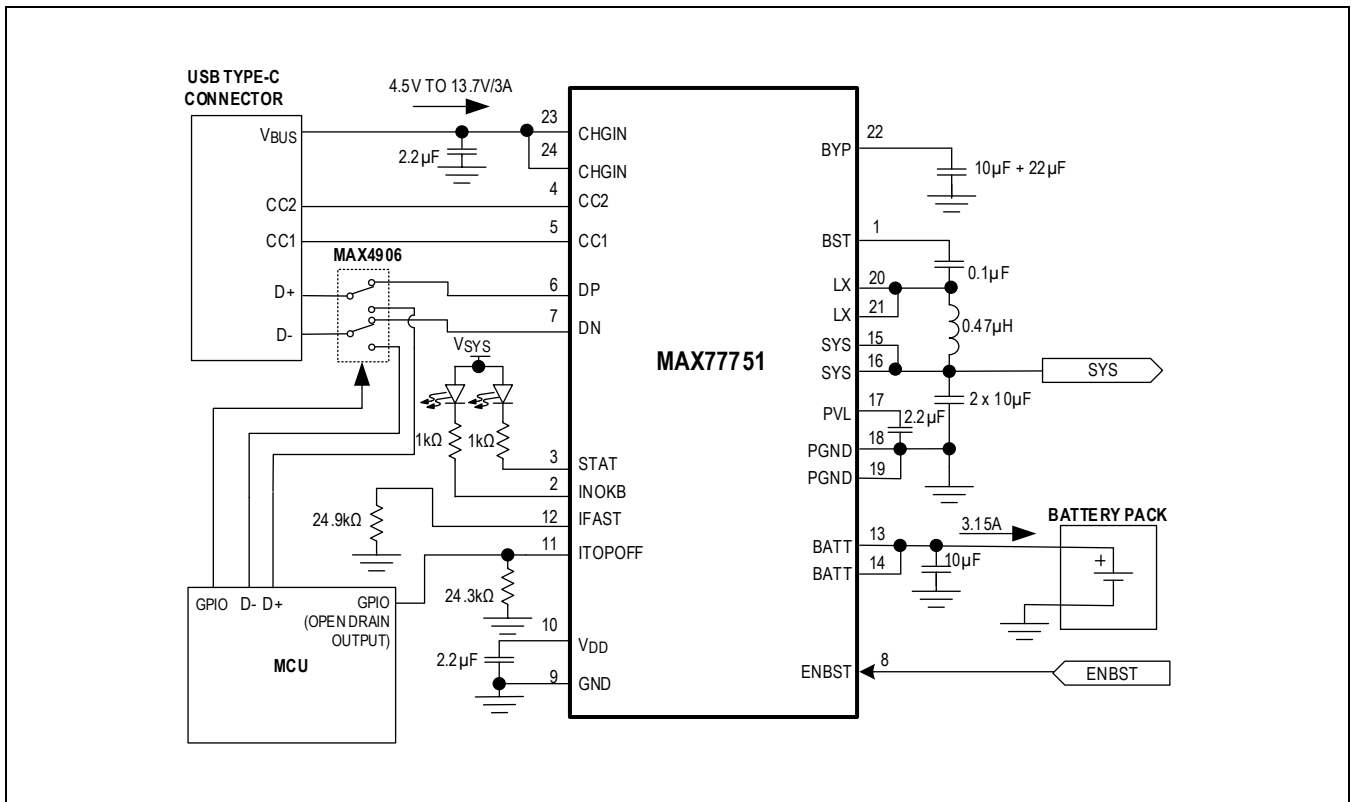

Figure 15. Typical Charger Application

## Ordering Information

PART NUMBER	TEMP RANGE	PIN-PACKAGE	BATTERY TERMINATION VOLTAGE (V)
MAX77751AEFG+	-40°C to +85°C	24 FC2QFN (3mm x 3mm)	4.10
MAX77751AEFG+T	-40°C to +85°C	24 FC2QFN (3mm x 3mm)	4.10
MAX77751BEFG+	-40°C to +85°C	24 FC2QFN (3mm x 3mm)	4.15
MAX77751BEFG+T	-40°C to +85°C	24 FC2QFN (3mm x 3mm)	4.15
MAX77751CEFG+	-40°C to +85°C	24 FC2QFN (3mm x 3mm)	4.20
MAX77751CEFG+T	-40°C to +85°C	24 FC2QFN (3mm x 3mm)	4.20
MAX77751DEFG+	-40°C to +85°C	24 FC2QFN (3mm x 3mm)	4.30
MAX77751DEFG+T	-40°C to +85°C	24 FC2QFN (3mm x 3mm)	4.30
MAX77751FEFG+	-40°C to +85°C	24 FC2QFN (3mm x 3mm)	4.35
MAX77751FEFG+T	-40°C to +85°C	24 FC2QFN (3mm x 3mm)	4.35
MAX77751GEFG+	-40°C to +85°C	24 FC2QFN (3mm x 3mm)	4.40
MAX77751GEFG+T	-40°C to +85°C	24 FC2QFN (3mm x 3mm)	4.40
MAX77751HEFG+	-40°C to +85°C	24 FC2QFN (3mm x 3mm)	4.45
MAX77751HEFG+T	-40°C to +85°C	24 FC2QFN (3mm x 3mm)	4.45
MAX77751JEFG+	-40°C to +85°C	24 FC2QFN (3mm x 3mm)	4.50
MAX77751JEFG+T	-40°C to +85°C	24 FC2QFN (3mm x 3mm)	4.50

+Denotes a lead(Pb)-free/RoHS-compliant package.

T = Tape and reel.

## Revision History

REVISION NUMBER	REVISION DATE	DESCRIPTION	PAGES CHANGED
0	6/20	Initial release	—
1	7/20	Updated the <i>Ordering Information</i> table	37
2	9/20	Updated the <i>Ordering Information</i> table	37
3	10/20	Updated <i>Functional Diagram</i> , <i>Input Current Limit</i> section, Figure 6, <i>Thermal Shutdown State</i> section, <i>Reverse Boost Mode</i> section, <i>USB BC1.2 Charger Detection</i> section, Table 1, Table 2, Table 5, and Figure 15; added <i>D+/D- Detection in CC Detection</i> , <i>Non-USB Type-C Connector Cases</i> , <i>Micro-B Connector</i> , and <i>Barrel Connectors</i> sections	16, 21, 23, 26, 27, 29–31, 33, 38
4	11/20	Updated the <i>Ordering Information</i> table	39

For pricing, delivery, and ordering information, please visit Maxim Integrated's online storefront at <https://www.maximintegrated.com/en/storefront/storefront.html>.

Maxim Integrated cannot assume responsibility for use of any circuitry other than circuitry entirely embodied in a Maxim Integrated product. No circuit patent licenses are implied. Maxim Integrated reserves the right to change the circuitry and specifications without notice at any time. The parametric values (min and max limits) shown in the *Electrical Characteristics* table are guaranteed. Other parametric values quoted in this data sheet are provided for guidance.



## X-ON Electronics

Largest Supplier of Electrical and Electronic Components

*Click to view similar products for [Battery Management](#) category:*

*Click to view products by [Maxim](#) manufacturer:*

Other Similar products are found below :

[MP26121DQ-LF-P](#) [NCP1855FCCT1G](#) [FAN54063UCX](#) [LC05132C01NMTTTG](#) [SN2040DSQR](#) [ME4075AM5G](#) [AP5054HTCER](#) [XPD977B](#)  
[XPD977B18](#) [4056H](#) [DW01](#) [DW06](#) [CM1002-UD](#) [CM1002-W](#) [CM1002-X](#) [CM1002-Y](#) [CM1006-B](#) [CM1006-Q](#) [CM1006-WB](#) [CM1006-LCD](#)  
[CM1006-LBD](#) [CM1006-WF](#) [CM1006-LF](#) [CM1006-WG](#) [CM1006-WH](#) [CM1006-LG](#) [CM1003-S02BD](#) [CM1003-S09EA](#) [CM1003-S10ED](#)  
[CM1003-S11ED](#) [CM1003-S12BC](#) [CM1003-S13CC](#) [CM1003-S24BC](#) [CM1003-S26BC](#) [CM1003-WAD](#) [CM1003-BBD](#) [CM1003-BFD](#)  
[CM1003-BND](#) [CM1003-BLD](#) [CM1003-DAD](#) [CM1003-BMD](#) [CM1003-BPD](#) [CM1003-BKD](#) [CM1003-BAE](#) [CM1003-BHE](#) [CM1102B-FF](#)  
[CM1102B-FD](#) [CM1102B-GD](#) [CM1112-DAE](#) [CM1112-DBE](#)